

New ICF Flexline™ stainless steel valve station in the meat industry

Temperature control all the way to the supermarket: Meet the new Danfoss ICF Flexline™ stainless steel valve station

In meat processing, reliable and smooth refrigeration systems are vital to maintain high levels of productivity and a constant supply of healthy, safe food. The powerful range of stainless steel line products from Danfoss has now been extended with a stainless steel version of the unique ICF Flexline™ stainless steel valve station – helping you design and operate better, more reliable refrigeration systems.

The world's

ONLY

stainless steel
valve station

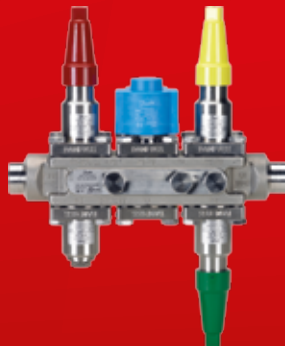

The ICF Flexline™ **stainless steel** valve station from Danfoss

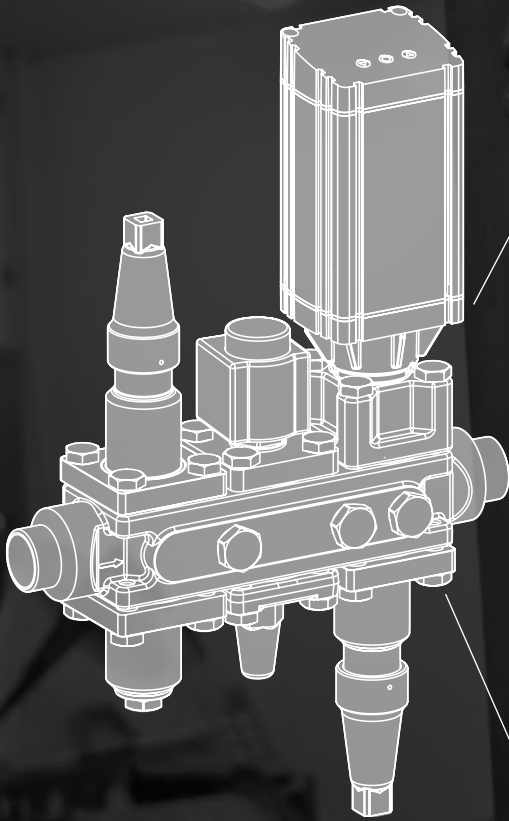

End-user benefits

- Perfectly suited for CO₂-based systems
- Low total cost of ownership
- Precise temperature control for optimum food safety
- Compatible with environmentally friendly refrigerants such as CO₂
- Fewer weldings equal minimized leak risk

Benefits for the contractor

- Easy to do service on your service contracts
- One code number for easier order and spare parts handling
- Less inventory space needed
- Compact design, low weight
- Fewer weldings equal minimized leak risk
- Full systems design freedom

One-stop shop

- Just one supplier needed for all component types
- The only stainless steel valve station in the market
- Innovation from the market leader in refrigeration technology
- Full range of support tools available for free
- Based on the tried and tested ICF stainless steel valve station concept
- Full compatibility with all stainless steel components from Danfoss

TWO

weldings instead
of six or more

Maximum food safety and longer shelf life: A complete range of **stainless steel** components for the meat industry

In meat processing, there is no room for unstable temperature conditions. Precise, accurate and reliable control of temperatures is vital in every single step of the production chain all the way from live animal to packaged food item. In modern meat processing facilities, low-impact high-pressure refrigerants such as CO₂ and ammonia are growing in popularity because of their unique characteristics as coolants and their low levels of environmental impact. But they require refrigeration components that can handle the high pressure and the extreme demands for hygiene. The Danfoss stainless steel component range, now complete with the new ICF stainless steel valve station, makes it easy to maintain high levels of hygiene and a stable, reliable temperature regimen throughout your entire production flow – all the way to the consumer's table.

This diagram shows some of the critical processes in meat processing plants, where Danfoss stainless steel products can make a real difference.

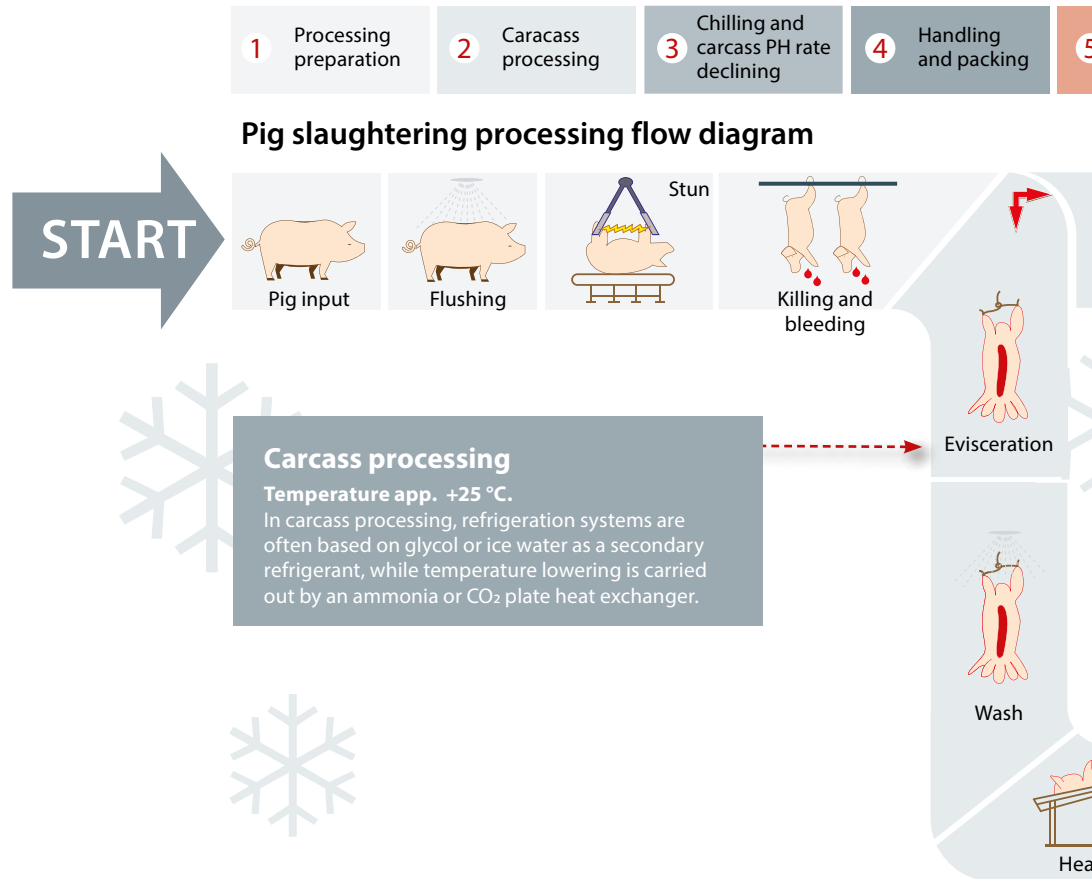

Chilling and carcass pH rate declining

Quick freezing or chilling systems are usually operated with ammonia or CO₂ as the primary refrigerant.

Rapid chilling (temperature below -15 °C):

- Builds up a coat of frost or ice to maintain the correct color of the product during storage
- Reduces purge loss and keep flesh weight

Conventional chilling (temperature app. 0 to +4 °C):

- Reduces shrinkage
- Rapid temperature reduction minimizes the growth of microorganisms on the carcass

Product range

SVL SS Flexline™ range:

The SVL SS Flexline™ range consists of a series of stainless steel valves based on the principle of one housing with many possible valve inserts. All functional inserts fit one of the two valve housings available (one straight, one angled), which makes it possible to keep a very low spare part stock and to service the valves quickly and efficiently.



Introducing the world's first **stainless steel** valve station

In meat processing, temperature control and hygiene are essential to ensure safe and consistent quality. Many meat production facilities rely on stainless steel components to ensure safe and hygienic production environments, and many are also shifting towards using CO₂ as the refrigerant of choice, as it's far safer and far more energy-efficient in daily use.



Replace many valves with one valve station

With the introduction of the new ICF stainless steel valve station from Danfoss, you can design and operate cooling lines for complete meat processing systems entirely from stainless steel, which makes it more energy-efficient and hygienic production lines with perfect temperature control characteristics.

One of the major advantages of the ICF stainless steel valve station concept is its compact size. Having just one valve housing for multiple functional inserts eliminates the need for several individual valves placed in-line. It reduces not just the complexity of the system – and the weight of it

– but more importantly, it reduces the number of welding needed, and with it the risk of leaks. Installations based on valve stations are much smaller, much easier to install and to service, and far more hygienic than conventional individual products.

A complete stainless steel range

The stainless steel ICF stainless steel valve station comes in two sizes: ICF 20 and ICF 25 with multiple connection types and sizes. It fits perfectly with all other stainless steel products for refrigeration in the meat processing such as the SVL SS Flexline™ range from Danfoss. See our complete stainless steel offering for industrial refrigeration in this brochure.

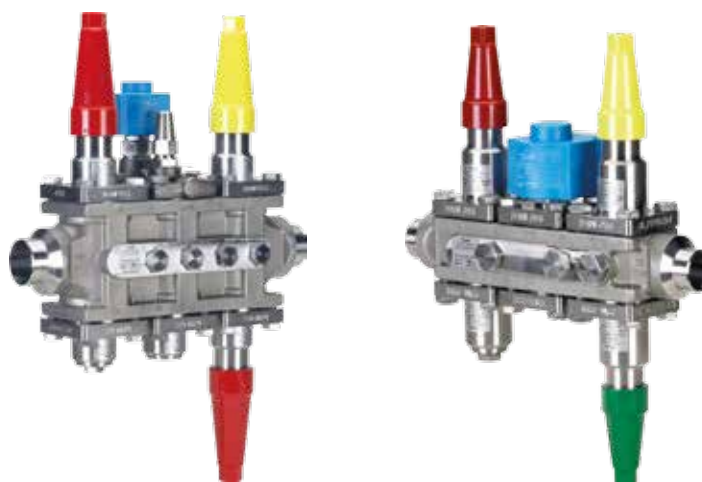

Danfoss Industrial Refrigeration

A world of expertise at the click of a button

Turn to Danfoss if you want to combine quality components with expert knowhow and support. Try out these free tools, designed to make your work much easier.



DIRbuilder

DIRbuilder is designed to make selection processes for industrial refrigeration projects easier and less time-consuming. Specify the valves you need from an extensive pool of configuration options. The DIRbuilder library comprises all Danfoss Industrial Refrigeration valves. Free of charge – no software needed.



Coolselector® 2 – New calculation software for Industrial Refrigeration

Coolselector® 2 is a calculation and support tool for contractors and system designers, offering complete pressure drop calculations, analysis of pipe and valve design and the ability to generate performance reports. It replaces the well-known DIRcalc™ software and offers several new functionalities.



Danfoss IR app

The free IR App gives you a spare parts tool, which makes it easy for you to find the spare part number for a given Danfoss industrial refrigeration valve.



Download 3D CAD symbols

From our online product catalogue on our website, you can download 3D CAD symbols and illustrations to help you when designing refrigeration plants.



IR application tool

With this interactive PowerPoint slideshow, you can explore all the details of a two-stage ammonia plant. You will find detailed cut-away drawings and information on the valves in the installation along with links to videos, literature and product animations.



Application handbook

The Application Handbook is designed to help you every step of the way when working with industrial refrigeration systems. Among many other things, it contains examples of how to select control methods for different refrigeration systems, their design and which components to choose.

Visit www.danfoss.com/IR-tools and find all the tools you need.