

Data sheet

Electric operated valves

Type CCM for R744 / CO₂



The CCM is an electrically operated valve designed specifically for operation in CO₂ systems. The valve is capable of functioning both as an expansion valve, and as a gas bypass valve with back-pressure regulation in subcritical applications.

The pressure rating allows for operation in environments where system standby capability is required without the need for auxiliary cooling systems during servicing or power outages.

Features

- Up to 90 bar (1305 psi) working pressure to accommodate CO₂ system pressures during standstill conditions.
- Precise positioning for optimal control of intermediate pressures in transcritical CO₂ systems or liquid injection in heat exchangers.
- MOPD up to 50 bar (725 psi).
- Combined stainless steel butt weld/solder connections for installation in copper piped systems (K65 alloy or standard) as well as steel piped systems.
- Standard M12 connector for simple and flexible connection to the motor driver.
- For manual operation and service of the CCM an AST-g service driver is available. For further information please contact Danfoss (Commercial Refrigeration and Air Conditioning Controls).
- *UL recognized.*

Data sheet | Electrically operated valves for CO₂, type CCM

Technical data

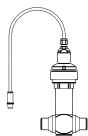

Parameter	CCM
Compatibility	R744
MOPD	50 bar (725 psi)
Max. working pressure (PS/MWP)	90 bar (1305 psi)
Refrigerant temperature range	-40°C to 60°C (-40°F to 140°F)
Ambient temperature	-40°C to 60°C (-40°F to 140°F)
Material of construction	Stainless steel

Electrical data

Parameter	CCM
Motor enclosure	IP 67
Stepper motor type	Bi-polar - permanent magnet
Step mode	2 phase full step
Phase resistance	52Ω ±10%
Phase inductance	85 mH
Holding current	Depends on application. Full current allowed (100% duty cycle)
Step angle	7.5° (motor), 0.9° (lead screw), Gearing ratio 8.5:1. (38/13) ² :1
Nominal voltage	(Constant voltage drive) 12 V dc -4% +15%, 150 steps/sec.
Phase current	(Using chopper drive) 100 mA RMS -4% +15%,
Max. total power	Voltage / current drive: 5.5 / 1.3 W (UL: NEC class 2)
Step rate	150 steps/sec. (constant voltage drive) 0-300 steps/sec. 300 recommended (chopper current drive)
Total steps	CCM 10, 20, 30 2625 [+160 / -0] steps CCM 40 3530 [+160 / -0] steps
Total stroke	13 mm / 16 mm (0.5 in. / 0.6 in.)
Full travel time	CCM 10, 20, 30 17 / 8.5 sec. (voltage / current) CCM 40 23 / 11.5 sec. (voltage / current)
Lifting height	CCM 10, 20, 30 13 mm (0.5 in.) CCM 40 16 mm (0.6 in.)
Reference position	Overdriving against the full close position
Electrical connection	4 wire 0.5 mm ² (0.02 in ²), 0.3 m (1 ft) long cable

Stepper motor switch sequence:

CCM valve Connector	Cable plug		
	4	Black	4
	3	White	3
	2	Green	2
	1	Red	1
	Connection 1	Wire Color	Connection 2
	Pin Out		

Stepper motor switch sequence:

	STEP	Coil I		Coil II		
		Red	Green	White	Black	
↑ CLOSING ↑	1	+	-	+	-	↓ OPENING ↓
	2	+	-	-	+	
	3	-	+	-	+	
	4	-	+	+	-	
	1	+	-	+	-	

Ordering

Valve incl. actuator - Single pack

Type	K _v m ³ /h	Connections (Combi)		Code nos single pack
		Weld ¹⁾ [in]	Solder ODF x ODF [in]	
CCM 10	0.8	1/2 x 1/2	5/8 x 5/8	027H7188
CCM 20	1.7	3/4 x 3/4	7/8 x 7/8	027H7187
CCM 30	2.5	1 x 1	1 1/8 x 1 1/8	027H7186
CCM 40	4.2	1 x 1	1 1/8 x 1 1/8	027H7185

¹⁾ OD according to EN 10220

Accessories:

Type	Description	Code number
	Cable with M12 connector - 8 meter (26.2 ft.)	034G2323
AST-G	Manual valve driver for service	034G0013

Spareparts:

Type	Description	Code number
AST	Actuator for CCM CO ₂ valve	027H7184
	O-ring spare part kit for CCM/CCMT (2 O-rings)	027H7230

Design

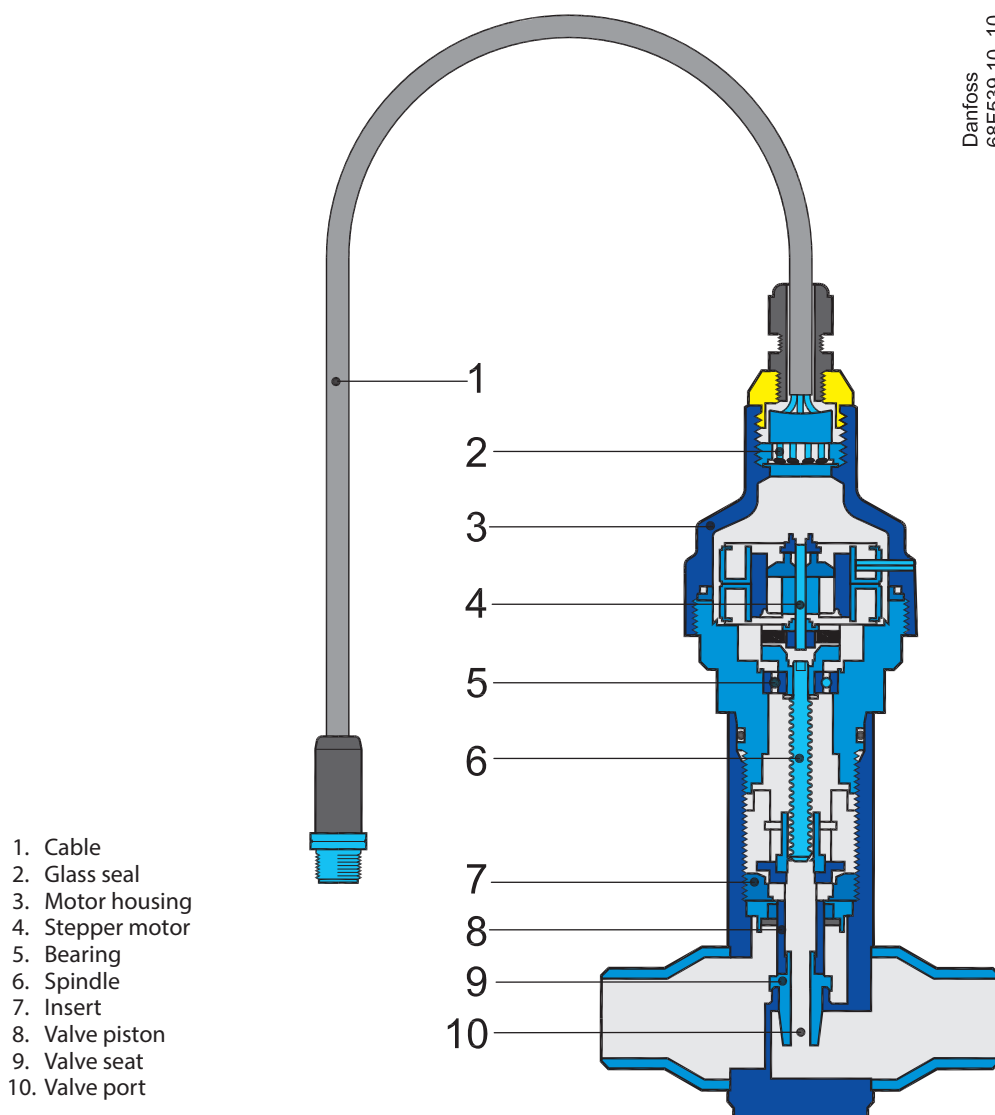

Danfoss
68F539.10 .10

Accessories:

M12 angle cable

M12 angle female connector is intended for use with a standard M12 male connector, available on stepper motor valves.

This cable is designed to offer high flexibility and small outer diameters with tensile strength. The angle way M12 cable consist of paired, twisted wires, which decreases mutual influence between signals transmitted along the cable and reduces influence of external sources of interference. The cables thus provides a higher degree of protection against lost steps compared to other cables.

Approvals



Specification

Jacket	PVC - black
Cable outer sheath	Oil - resistant
Water proof rating	IP 67
Operating temperature range	-40 – +80 °C
Wire type	Twisted pair, cross section 20 AWG / 0.5 mm ²
Cable outer diameter	7.0 mm
Minimum bending radius	10 x cable diameter
Cable combustibility / test	Flame retardant / VW-1 / CSA FT - 1
M12 standard	EN 61076-2-101
Reference standard	UL style 2464 and DIN VDE 0812
LVD directive	73/23/EEC and 93/68/EEC

Ordering

Cable	Cable length (L)	Insulation	Packing format	Code no.
PVC - black	2 m / 6.6 ft	SR-PVC	Single pack	034G7073
	8 m / 26.2 ft	SR-PVC	Single pack	034G7074

Identification

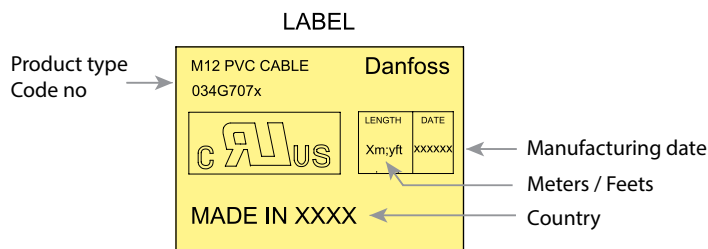

Connections



Dimensions

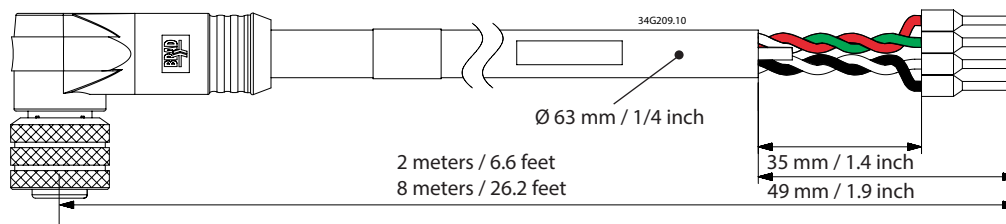

Valve operation

The CCM can be used in a variety of applications within CO₂ refrigeration systems. Typically it is

used as a gas bypass valve in a transcritical CO₂ booster system or as an expansion valve.

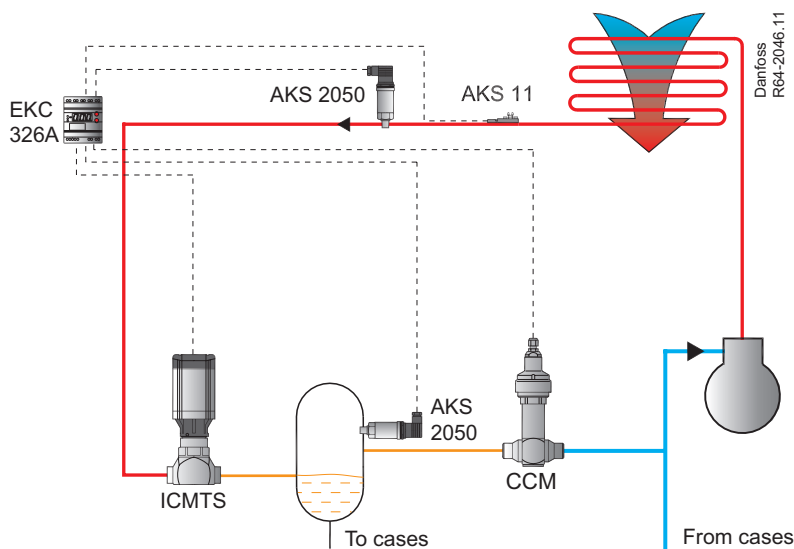

Application 1

A gas bypass valve is typically used to regulate the intermediate pressure in a transcritical CO₂ refrigeration system. By venting flashgas generated after the transcritical expansion, the pressure can

be kept at a safe level for all components situated in the liquid lines of a transcritical CO₂ system. For use in the gas bypass application the EKC326A controller is recommended.

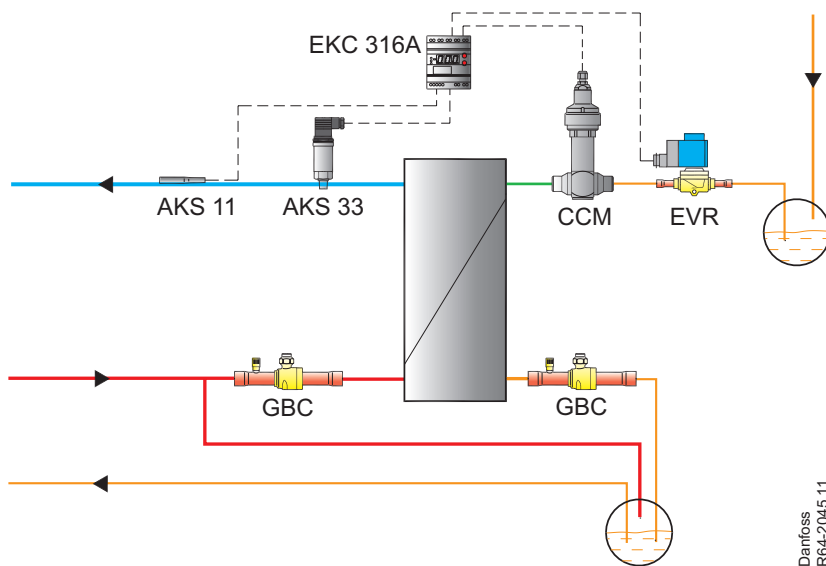

Application 2

A liquid expansion valve is typically used for injection in plate heat exchangers of CO₂/CO₂ cascades, or as an expansion valve for CO₂ evaporators. For the

liquid injection applications CCM is used with EKC 316A controller.

Valve operation (Cont.)

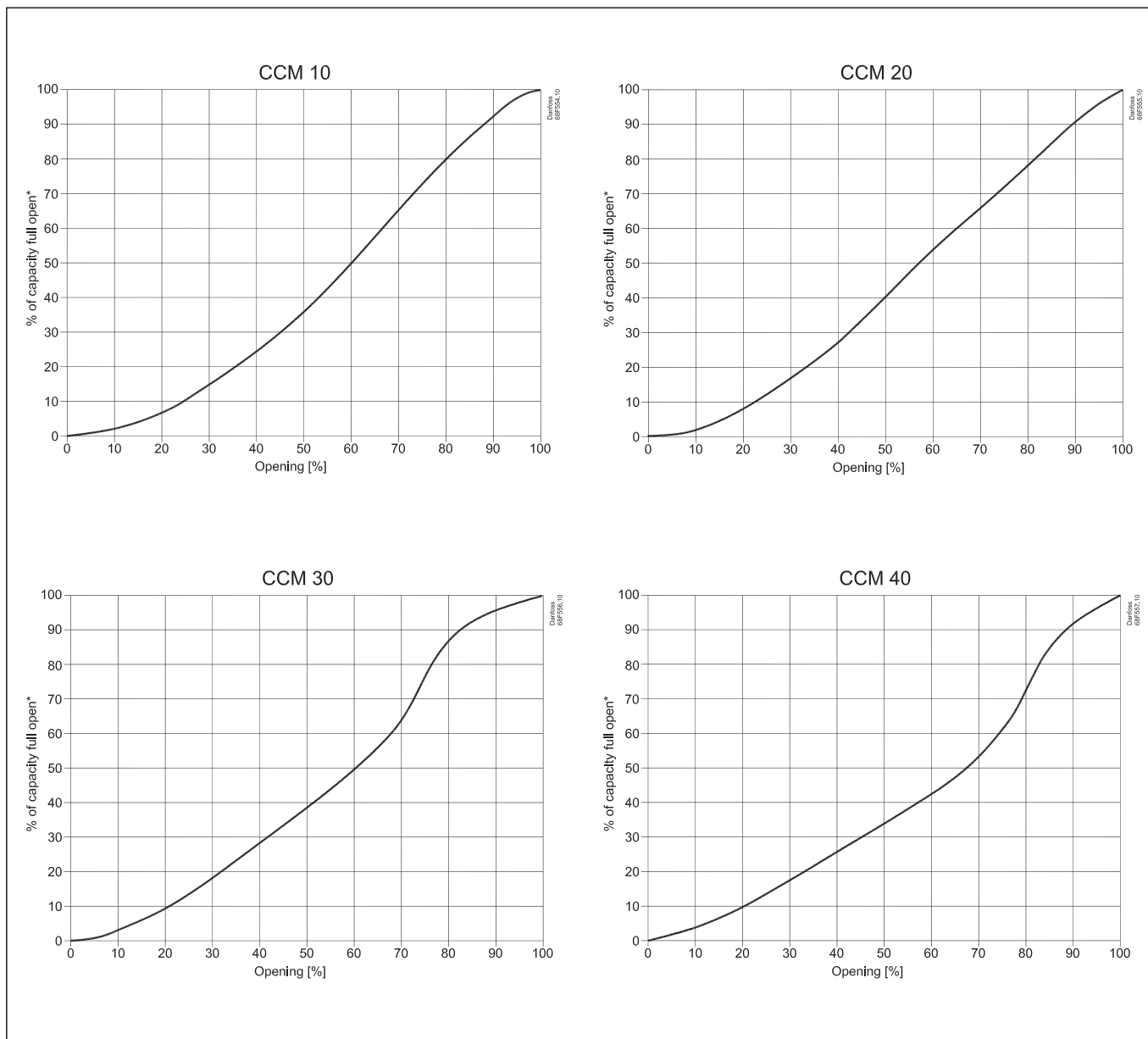

Sizing and capacities

The following tables indicate nominal capacities of the valve in the gas bypass application and in the liquid expansion application with R744 (CO₂) as refrigerant. Capacities are given for varying operating conditions within the normal range

of the valve. If the capacity shown in the table is higher than 75% of the required capacity, then it is recommended to use a valve one size larger, or as an alternative, to use an additional valve in parallel.

Data sheet | Electrically operated valves for CO₂ type CCM

Gas Bypass Application

The capacities shown are based on the amount of flash gas produced when expanding from supercritical CO₂ before the transcritical expansion valve (ICMTS) at 35°C and the corresponding

optimal high pressure setting (89 bar) as set by the Danfoss EKC326A controller. The capacities shown are the total system evaporating capacity at the given evaporating temperature.

CCM 10

		Gas cooler															
Outlet [°C]		20	22	24	26	28	30	32	34	36	38	40	42	44	46	48	50
Pressure [bar]		60.7	63.6	66.5	69.4	72.3	76.4	81.6	86.8	92.0	97.2	102.4	107.6	112.8	118.0	123.2	128.4
Receiver [°C]	NT evap. [°C]	Capacity [kW]															
15	10	343.0	225.1	158.7	115.4	83.7	91.8	81.3	72.9	66.0	60.1	55.1	50.8	46.9	43.4	40.3	37.4
	5	459.3	301.4	212.5	154.5	112.1	122.9	108.8	97.6	88.3	80.5	73.8	68.0	62.8	58.1	53.9	50.1
	0	531.8	349.1	246.1	178.9	129.8	142.4	126.0	113.0	102.3	93.2	85.5	78.7	72.7	67.3	62.5	58.1
	-5	579.7	380.5	268.3	195.0	141.4	155.2	137.4	123.2	111.5	101.6	93.2	85.8	79.2	73.4	68.1	63.3
	-10	610.9	400.9	282.7	205.5	149.0	163.5	144.7	129.8	117.5	107.1	98.2	90.4	83.5	77.3	71.7	66.7
10	5	183.3	141.0	110.2	86.3	66.4	71.7	64.8	59.1	54.3	50.1	46.4	43.2	40.3	37.6	35.2	33.0
	0	243.5	187.3	146.4	114.6	88.2	95.3	86.1	78.5	72.1	66.5	61.7	57.4	53.5	50.0	46.7	43.8
	-5	279.6	215.1	168.1	131.6	101.3	109.4	98.8	90.1	82.8	76.4	70.8	65.9	61.4	57.4	53.7	50.3
	-10	302.1	232.4	181.6	142.2	109.5	118.2	106.8	97.4	89.4	82.6	76.6	71.2	66.4	62.0	58.0	54.3
	-15	315.4	242.6	189.6	148.4	114.3	123.4	111.5	101.7	93.4	86.2	79.9	74.3	69.3	64.7	60.6	56.7
5	0	125.2	102.3	83.8	68.2	54.3	58.1	53.2	49.0	45.4	42.2	39.4	36.9	34.6	32.5	30.6	28.8
	-5	165.1	134.9	110.5	89.9	71.6	76.6	70.1	64.6	59.9	55.7	52.0	48.7	45.7	42.9	40.4	38.0
	-10	188.1	153.7	125.9	102.5	81.6	87.3	79.9	73.6	68.2	63.5	59.3	55.5	52.1	48.9	46.0	43.3
	-15	201.6	164.8	135.0	109.8	87.5	93.6	85.6	78.9	73.1	68.0	63.5	59.5	55.8	52.4	49.3	46.4
	-20	208.6	170.5	139.7	113.7	90.6	96.9	88.6	81.7	75.7	70.4	65.8	61.6	57.7	54.2	51.0	48.0
0	-5	93.4	78.8	66.4	55.3	45.1	47.9	44.2	41.0	38.2	35.8	33.6	31.6	29.8	28.1	26.5	25.1
	-10	122.3	103.3	86.9	72.5	59.0	62.8	57.9	53.7	50.1	46.9	44.0	41.4	39.0	36.8	34.7	32.8
	-15	138.3	116.8	98.3	82.0	66.8	71.0	65.5	60.8	56.7	53.0	49.8	46.8	44.1	41.6	39.3	37.1
	-20	147.1	124.2	104.6	87.2	71.0	75.5	69.7	64.6	60.3	56.4	52.9	49.8	46.9	44.2	41.8	39.5
-5	-10	72.6	62.6	53.7	45.5	37.7	39.9	37.0	34.5	32.3	30.4	28.6	27.0	25.5	24.1	22.9	21.7
	-15	94.5	81.5	69.8	59.2	49.0	51.9	48.1	44.9	42.0	39.5	37.2	35.1	33.2	31.4	29.8	28.2
	-20	106.1	91.5	78.5	66.5	55.1	58.3	54.1	50.4	47.2	44.4	41.8	39.5	37.3	35.3	33.4	31.7
	-25	112.0	96.6	82.8	70.2	58.1	61.5	57.1	53.2	49.8	46.8	44.1	41.6	39.4	37.2	35.3	33.4
-10	-15	57.8	50.5	43.9	37.7	31.6	33.3	31.0	29.1	27.3	25.7	24.3	23.0	21.8	20.7	19.6	18.6
	-20	74.7	65.3	56.7	48.7	40.8	43.0	40.1	37.5	35.3	33.3	31.4	29.7	28.2	26.7	25.4	24.1
	-25	83.3	72.9	63.3	54.3	45.5	48.0	44.7	41.9	39.4	37.1	35.1	33.2	31.4	29.8	28.3	26.9
	-30	87.3	76.3	66.3	56.9	47.7	50.3	46.8	43.9	41.2	38.9	36.7	34.8	32.9	31.2	29.6	28.2
-15	-20	46.6	41.2	36.1	31.3	26.4	27.8	26.0	24.4	23.0	21.8	20.6	19.6	18.6	17.6	16.8	16.0
	-25	59.8	52.8	46.3	40.1	34.0	35.7	33.4	31.4	29.6	27.9	26.5	25.1	23.8	22.6	21.5	20.5
	-30	66.2	58.5	51.3	44.4	37.6	39.5	37.0	34.7	32.7	30.9	29.3	27.8	26.4	25.1	23.8	22.7
	-35	68.8	60.8	53.3	46.2	39.1	41.1	38.4	36.1	34.0	32.2	30.5	28.9	27.4	26.1	24.8	23.6

Data sheet | Electrically operated valves for CO₂ type CCM
Gas Bypass Application (continued)

CCM 20

		Gas cooler															
Outlet [°C]		20	22	24	26	28	30	32	34	36	38	40	42	44	46	48	50
Pressure [bar]		60.7	63.6	66.5	69.4	72.3	76.4	81.6	86.8	92.0	97.2	102.4	107.6	112.8	118.0	123.2	128.4
Receiver [°C]	NT evap. [°C]	Capacity [kW]															
		15	10	686.1	450.3	317.5	230.7	167.4	183.6	162.6	145.7	131.9	120.3	110.3	101.5	93.8	86.8
5	918.6		602.9	425.1	308.9	224.1	245.9	217.7	195.1	176.6	161.0	147.6	135.9	125.5	116.3	107.9	100.3
0	1064		698.1	492.2	357.7	259.5	284.7	252.0	226.0	204.5	186.5	170.9	157.4	145.4	134.6	124.9	116.1
-5	1159		761.0	536.6	390.0	282.9	310.4	274.7	246.3	222.9	203.3	186.3	171.5	158.5	146.7	136.2	126.6
-10	1222		801.9	565.4	410.9	298.1	327.0	289.5	259.5	234.9	214.2	196.3	180.8	167.0	154.6	143.5	133.4
10	5	366.5	282.0	220.4	172.5	132.8	143.4	129.6	118.2	108.5	100.2	92.9	86.4	80.5	75.2	70.4	65.9
	0	486.9	374.6	292.7	229.2	176.4	190.5	172.2	157.0	144.2	133.1	123.4	114.7	107.0	99.9	93.5	87.6
	-5	559.2	430.2	336.1	263.2	202.6	218.8	197.7	180.3	165.6	152.8	141.7	131.8	122.9	114.8	107.4	100.6
	-10	604.2	464.8	363.2	284.3	218.9	236.4	213.6	194.8	178.9	165.2	153.1	142.4	132.7	124.0	116.0	108.7
	-15	630.8	485.3	379.2	296.9	228.5	246.8	223.0	203.4	186.8	172.4	159.8	148.6	138.6	129.5	121.1	113.4
5	0	250.3	204.6	167.6	136.4	108.6	116.2	106.3	98.0	90.8	84.5	78.9	73.8	69.3	65.1	61.2	57.6
	-5	330.1	269.8	221.0	179.9	143.3	153.3	140.2	129.2	119.7	111.4	104.0	97.4	91.4	85.8	80.7	76.0
	-10	376.2	307.5	251.9	205.0	163.3	174.7	159.8	147.2	136.4	127.0	118.6	111.0	104.1	97.8	92.0	86.6
	-15	403.2	329.6	269.9	219.7	175.0	187.2	171.3	157.8	146.2	136.1	127.1	119.0	111.6	104.8	98.6	92.8
	-20	417.3	341.1	279.4	227.4	181.1	193.8	177.3	163.3	151.3	140.8	131.5	123.1	115.5	108.5	102.1	96.1
0	-5	186.7	157.7	132.7	110.7	90.2	95.9	88.4	82.0	76.5	71.6	67.2	63.2	59.5	56.2	53.0	50.1
	-10	244.5	206.5	173.9	144.9	118.1	125.6	115.8	107.5	100.2	93.8	88.0	82.8	78.0	73.6	69.5	65.6
	-15	276.7	233.6	196.7	164.0	133.6	142.0	131.0	121.6	113.3	106.1	99.5	93.6	88.2	83.2	78.6	74.2
	-20	294.2	248.5	209.2	174.4	142.1	151.1	139.3	129.3	120.5	112.8	105.9	99.6	93.8	88.5	83.6	79.0
-5	-10	145.3	125.2	107.4	91.0	75.3	79.7	74.0	69.0	64.6	60.7	57.2	54.0	51.0	48.3	45.7	43.3
	-15	189.0	162.9	139.7	118.4	98.0	103.7	96.3	89.8	84.1	79.0	74.4	70.3	66.4	62.8	59.5	56.4
	-20	212.3	183.0	156.9	133.0	110.1	116.5	108.1	100.8	94.5	88.8	83.6	78.9	74.6	70.6	66.8	63.3
	-25	224.1	193.1	165.6	140.4	116.2	123.0	114.1	106.4	99.7	93.7	88.3	83.3	78.7	74.5	70.6	66.9
-10	-15	115.6	101.1	87.8	75.3	63.1	66.6	62.0	58.1	54.6	51.5	48.6	46.0	43.6	41.4	39.3	37.3
	-20	149.4	130.6	113.5	97.4	81.6	86.1	80.2	75.1	70.6	66.5	62.9	59.5	56.4	53.5	50.8	48.2
	-25	166.6	145.7	126.6	108.6	91.0	96.0	89.4	83.8	78.7	74.2	70.1	66.4	62.9	59.6	56.6	53.8
	-30	174.5	152.6	132.6	113.7	95.3	100.5	93.7	87.7	82.5	77.7	73.4	69.5	65.9	62.5	59.3	56.3
-15	-20	93.1	82.3	72.2	62.5	52.9	55.6	52.0	48.9	46.1	43.5	41.2	39.1	37.1	35.3	33.5	31.9
	-25	119.6	105.7	92.7	80.3	67.9	71.4	66.8	62.8	59.1	55.9	52.9	50.2	47.7	45.3	43.1	41.0
	-30	132.4	117.0	102.6	88.9	75.2	79.1	74.0	69.5	65.5	61.9	58.6	55.6	52.8	50.2	47.7	45.4
	-35	137.6	121.6	106.7	92.4	78.1	82.2	76.9	72.2	68.1	64.3	60.9	57.8	54.9	52.1	49.6	47.2

Data sheet | Electrically operated valves for CO₂ type CCM

Gas Bypass Application (continued)

CCM 30

		Gas cooler															
Outlet [°C]		20	22	24	26	28	30	32	34	36	38	40	42	44	46	48	50
Pressure [bar]		60.7	63.6	66.5	69.4	72.3	76.4	81.6	86.8	92.0	97.2	102.4	107.6	112.8	118.0	123.2	128.4
Receiver [°C]	NT evap. [°C]	Capacity [kW]															
		15	10	1029	675.4	476.2	346.1	251.1	275.5	243.8	218.6	197.9	180.4	165.4	152.3	140.6	130.2
5	1378		904.3	637.6	463.4	336.2	368.8	326.5	292.7	264.9	241.5	221.4	203.9	188.3	174.4	161.8	150.4
0	1595		1047	738.3	536.6	389.3	427.1	378.0	338.9	306.8	279.7	256.4	236.0	218.0	201.9	187.4	174.2
-5	1739		1142	804.9	584.9	424.3	465.5	412.1	369.5	334.4	304.9	279.5	257.3	237.7	220.1	204.3	189.9
-10	1833		1203	848.1	616.4	447.1	490.6	434.2	389.3	352.4	321.3	294.5	271.1	250.5	231.9	215.2	200.1
10	5	549.8	423.0	330.5	258.8	199.2	215.1	194.4	177.3	162.8	150.3	139.3	129.6	120.8	112.8	105.6	98.9
	0	730.4	561.9	439.1	343.7	264.6	285.8	258.2	235.5	216.2	199.6	185.1	172.1	160.5	149.9	140.2	131.3
	-5	838.7	645.2	504.2	394.7	303.9	328.2	296.5	270.4	248.3	229.3	212.5	197.7	184.3	172.1	161.0	150.8
	-10	906.3	697.2	544.8	426.5	328.4	354.6	320.4	292.2	268.3	247.7	229.7	213.6	199.1	186.0	174.0	163.0
	-15	946.2	727.9	568.8	445.3	342.8	370.2	334.5	305.1	280.1	258.6	239.8	223.0	207.9	194.2	181.7	170.1
5	0	375.5	306.9	251.4	204.6	163.0	174.4	159.5	147.0	136.2	126.7	118.3	110.8	103.9	97.6	91.8	86.4
	-5	495.2	404.7	331.5	269.8	214.9	229.9	210.3	193.8	179.6	167.1	156.1	146.1	137.0	128.7	121.1	114.0
	-10	564.3	461.2	377.8	307.4	244.9	262.0	239.7	220.9	204.6	190.5	177.8	166.5	156.2	146.7	138.0	129.9
	-15	604.8	494.3	404.9	329.5	262.5	280.8	256.9	236.7	219.3	204.1	190.6	178.4	167.4	157.2	147.9	139.2
	-20	625.9	511.6	419.1	341.0	271.7	290.7	265.9	245.0	227.0	211.3	197.3	184.7	173.2	162.7	153.1	144.1
0	-5	280.1	236.5	199.1	166.0	135.2	143.8	132.6	123.1	114.7	107.4	100.8	94.8	89.3	84.2	79.5	75.2
	-10	366.8	309.8	260.8	217.4	177.1	188.3	173.7	161.2	150.3	140.6	132.0	124.1	117.0	110.3	104.2	98.4
	-15	415.0	350.5	295.0	246.0	200.4	213.1	196.5	182.3	170.0	159.1	149.3	140.4	132.3	124.8	117.9	111.4
	-20	441.3	372.7	313.8	261.6	213.1	226.6	209.0	193.9	180.8	169.2	158.8	149.4	140.7	132.7	125.3	118.4
-5	-10	217.9	187.8	161.0	136.5	113.0	119.6	111.0	103.5	96.9	91.1	85.8	81.0	76.6	72.4	68.6	65.0
	-15	283.5	244.4	209.5	177.6	147.0	155.6	144.4	134.7	126.1	118.5	111.7	105.4	99.6	94.3	89.3	84.6
	-20	318.4	274.5	235.4	199.5	165.2	174.8	162.2	151.3	141.7	133.1	125.4	118.4	111.9	105.9	100.3	95.0
	-25	336.1	289.7	248.4	210.6	174.3	184.5	171.2	159.7	149.5	140.5	132.4	124.9	118.1	111.7	105.8	100.3
-10	-15	173.4	151.6	131.7	113.0	94.7	99.9	93.1	87.2	81.9	77.2	73.0	69.1	65.4	62.1	58.9	55.9
	-20	224.1	196.0	170.2	146.1	122.4	129.1	120.3	112.6	105.9	99.8	94.3	89.2	84.6	80.2	76.1	72.3
	-25	249.9	218.6	189.8	162.9	136.5	144.0	134.2	125.6	118.1	111.3	105.2	99.5	94.3	89.5	84.9	80.6
	-30	261.8	228.9	198.8	170.6	143.0	150.8	140.5	131.6	123.7	116.6	110.2	104.3	98.8	93.7	88.9	84.5
-15	-20	139.7	123.5	108.3	93.8	79.3	83.5	78.0	73.3	69.1	65.3	61.8	58.7	55.7	52.9	50.3	47.9
	-25	179.4	158.5	139.0	120.4	101.9	107.1	100.2	94.1	88.7	83.8	79.4	75.3	71.5	67.9	64.6	61.5
	-30	198.6	175.5	154.0	133.3	112.8	118.6	111.0	104.2	98.2	92.8	87.9	83.4	79.2	75.2	71.5	68.1
	-35	206.4	182.4	160.0	138.6	117.2	123.3	115.3	108.3	102.1	96.5	91.4	86.7	82.3	78.2	74.4	70.7

Data sheet | Electrically operated valves for CO₂ type CCM

Gas Bypass Application (continued)

CCM 40

		Gas cooler															
Outlet [°C]		20	22	24	26	28	30	32	34	36	38	40	42	44	46	48	50
Pressure [bar]		60.7	63.6	66.5	69.4	72.3	76.4	81.6	86.8	92.0	97.2	102.4	107.6	112.8	118.0	123.2	128.4
Receiver [°C]	NT evap. [°C]	Capacity [kW]															
		15	10	1801	1182	833.4	605.7	439.4	482.1	426.7	382.6	346.3	315.7	289.4	266.4	246.1	227.9
5	2411		1583	1116	811.0	588.3	645.4	571.3	512.2	463.6	422.7	387.5	356.7	329.5	305.2	283.2	263.2
0	2792		1833	1292	939.1	681.2	747.4	661.6	593.1	536.9	489.5	448.7	413.1	381.6	353.4	327.9	304.8
-5	3044		1998	1409	1024	742.6	814.7	721.2	646.6	585.2	533.5	489.1	450.3	415.9	385.2	357.5	332.3
-10	3207		2105	1484	1079	782.5	858.5	759.9	681.3	616.7	562.2	515.4	474.5	438.3	405.9	376.7	350.1
10	5	962.2	740.2	578.4	452.8	348.6	376.5	340.2	310.2	284.9	263.0	243.8	226.8	211.4	197.5	184.7	173.0
	0	1278	983.3	768.4	601.5	463.1	500.1	451.9	412.1	378.4	349.4	323.9	301.2	280.8	262.3	245.4	229.9
	-5	1468	1129	882.4	690.8	531.8	574.3	519.0	473.2	434.6	401.2	371.9	345.9	322.5	301.2	281.8	264.0
	-10	1586	1220	953.4	746.4	574.7	620.6	560.8	511.4	469.6	433.5	401.9	373.8	348.5	325.5	304.5	285.2
	-15	1656	1274	995.4	779.2	599.9	647.9	585.4	533.8	490.2	452.6	419.6	390.2	363.8	339.8	317.9	297.8
5	0	657.1	537.1	439.9	358.0	285.2	305.1	279.1	257.2	238.3	221.8	207.1	193.9	181.8	170.8	160.7	151.3
	-5	866.5	708.3	580.2	472.1	376.1	402.4	368.1	339.2	314.3	292.5	273.1	255.7	239.8	225.3	211.9	199.5
	-10	987.5	807.2	661.1	538.0	428.6	458.6	419.5	386.5	358.1	333.3	311.2	291.3	273.3	256.7	241.5	227.4
	-15	1058	865.1	708.6	576.7	459.4	491.5	449.6	414.2	383.8	357.2	333.5	312.3	292.9	275.2	258.8	243.7
	-20	1095	895.4	733.4	596.8	475.5	508.7	465.3	428.7	397.3	369.7	345.2	323.2	303.1	284.8	267.9	252.2
0	-5	490.1	413.9	348.5	290.5	236.7	251.6	232.1	215.4	200.8	187.9	176.4	165.9	156.3	147.4	139.2	131.5
	-10	641.9	542.1	456.4	380.5	310.0	329.6	304.0	282.1	263.0	246.1	231.0	217.3	204.7	193.1	182.3	172.3
	-15	726.2	613.3	516.3	430.4	350.7	372.9	343.9	319.1	297.5	278.4	261.3	245.8	231.6	218.4	206.3	194.9
	-20	772.3	652.2	549.1	457.8	373.0	396.5	365.7	339.4	316.4	296.1	277.9	261.4	246.3	232.3	219.4	207.3
-5	-10	381.3	328.7	281.8	238.9	197.8	209.3	194.2	181.1	169.7	159.4	150.2	141.8	134.0	126.8	120.1	113.8
	-15	496.1	427.7	366.7	310.8	257.3	272.3	252.7	235.7	220.7	207.4	195.4	184.4	174.3	165.0	156.2	148.0
	-20	557.3	480.4	411.9	349.1	289.0	305.9	283.8	264.7	248.0	233.0	219.5	207.2	195.8	185.3	175.5	166.3
	-25	588.1	507.0	434.7	368.5	305.1	322.9	299.5	279.4	261.7	245.9	231.7	218.7	206.7	195.6	185.2	175.5
-10	-15	303.4	265.3	230.5	197.7	165.7	174.8	162.9	152.5	143.4	135.1	127.7	120.8	114.5	108.6	103.1	97.9
	-20	392.2	342.9	297.9	255.6	214.2	225.9	210.5	197.1	185.3	174.7	165.0	156.2	148.0	140.4	133.2	126.5
	-25	437.4	382.5	332.2	285.1	238.9	251.9	234.8	219.9	206.7	194.8	184.1	174.2	165.1	156.6	148.6	141.1
	-30	458.1	400.6	348.0	298.6	250.2	263.9	245.9	230.3	216.5	204.1	192.8	182.5	172.9	164.0	155.7	147.8
-15	-20	244.5	216.1	189.5	164.1	138.8	146.0	136.6	128.3	120.9	114.3	108.2	102.6	97.5	92.6	88.1	83.8
	-25	313.9	277.4	243.3	210.7	178.3	187.5	175.4	164.7	155.3	146.7	138.9	131.8	125.1	118.9	113.1	107.6
	-30	347.6	307.2	269.4	233.4	197.4	207.6	194.2	182.4	171.9	162.5	153.9	145.9	138.5	131.7	125.2	119.1
	-35	361.2	319.2	280.0	242.5	205.1	215.8	201.8	189.6	178.7	168.9	159.9	151.7	144.0	136.8	130.1	123.8

Liquid Expansion Application

Valve capacities when operating as an expansion valve are given in the following table for different evaporating temperatures (t_e) and varying pressure differences over the valve. The values shown are based on 0.1 K liquid subcooling at the inlet to

the valve and no useful superheat. Capacities can be adjusted for different levels of subcooling by multiplying the capacity found in the table below, by the capacity correction factor found in the subsequent table.

CCM 10

		Condensation										
Outlet [°C]		-20	-15	-10	-5	0	5	10	15	20	25	30
	[°C]	Capacity [kW]										
Evaporation	25	-	-	-	-	-	-	-	-	-	-	25
	20	-	-	-	-	-	-	-	-	-	36	39
	15	-	-	-	-	-	-	-	-	43	53	50
	10	-	-	-	-	-	-	-	48	61	66	59
	5	-	-	-	-	-	-	51	67	75	76	67
	0	-	-	-	-	-	54	72	82	86	85	73
	-5	-	-	-	-	55	75	87	94	96	92	79
	-10	-	-	-	56	77	90	98	103	103	98	83
	-15	-	-	57	78	92	102	108	111	109	103	87
	-20	-	57	78	93	104	111	116	117	115	107	90
	-25	56	78	93	105	113	119	122	122	119	111	92
	-30	77	93	105	114	121	125	127	127	122	113	94
	-35	92	104	114	121	127	130	131	130	125	115	96
	-40	103	113	121	127	132	134	135	133	127	117	97
-45	111	120	127	132	136	137	137	135	129	118	97	

CCM 20

		Condensation										
Outlet [°C]		-20	-15	-10	-5	0	5	10	15	20	25	30
	[°C]	Capacity [kW]										
Evaporation	25	-	-	-	-	-	-	-	-	-	-	48
	20	-	-	-	-	-	-	-	-	-	70	76
	15	-	-	-	-	-	-	-	-	84	103	98
	10	-	-	-	-	-	-	-	93	120	128	116
	5	-	-	-	-	-	-	100	132	147	149	131
	0	-	-	-	-	-	105	140	160	169	166	143
	-5	-	-	-	-	108	146	170	183	187	180	154
	-10	-	-	-	110	150	176	193	201	202	192	163
	-15	-	-	111	152	180	199	211	216	214	202	170
	-20	-	111	153	182	203	218	226	229	224	210	176
	-25	110	153	183	205	221	233	239	239	233	217	181
	-30	151	182	205	223	236	245	249	248	239	222	185
	-35	180	204	223	237	248	255	257	254	245	226	187
	-40	201	221	236	249	258	263	264	259	249	229	189
-45	217	234	248	258	265	269	268	263	252	231	190	

Liquid Expansion Application
(continued)

CCM 30

		Condensation										
Outlet [°C]		-20	-15	-10	-5	0	5	10	15	20	25	30
[°C]		Capacity [kW]										
Evaporation	25	-	-	-	-	-	-	-	-	-	-	75
	20	-	-	-	-	-	-	-	-	-	109	117
	15	-	-	-	-	-	-	-	-	130	159	151
	10	-	-	-	-	-	-	-	144	186	198	179
	5	-	-	-	-	-	-	155	204	227	230	202
	0	-	-	-	-	-	162	217	248	261	256	222
	-5	-	-	-	-	167	226	262	283	289	278	238
	-10	-	-	-	170	232	272	298	311	312	297	252
	-15	-	-	172	235	278	308	326	335	331	312	263
	-20	-	172	237	281	314	336	350	354	347	325	272
	-25	170	236	282	317	342	360	369	370	360	335	280
	-30	234	281	317	345	365	379	385	383	370	343	285
	-35	278	315	344	367	383	394	397	393	378	349	289
	-40	310	341	365	385	398	406	407	401	384	353	292
-45	336	362	382	399	410	415	415	407	389	356	293	

CCM 40

		Condensation										
Outlet [°C]		-20	-15	-10	-5	0	5	10	15	20	25	30
[°C]		Capacity [kW]										
Evaporation	25	-	-	-	-	-	-	-	-	-	-	128
	20	-	-	-	-	-	-	-	-	-	186	200
	15	-	-	-	-	-	-	-	-	222	272	258
	10	-	-	-	-	-	-	-	247	317	339	306
	5	-	-	-	-	-	-	265	349	389	393	345
	0	-	-	-	-	-	277	371	424	446	438	379
	-5	-	-	-	-	286	386	448	483	494	476	407
	-10	-	-	-	291	397	465	509	532	533	507	430
	-15	-	-	293	402	475	526	558	572	566	533	450
	-20	-	293	404	481	536	575	598	605	593	555	466
	-25	291	403	482	541	585	615	631	632	615	572	478
	-30	400	480	542	589	624	647	658	654	632	586	488
	-35	475	538	588	627	655	673	679	671	646	596	495
	-40	531	583	625	657	680	694	696	685	657	604	499
-45	574	618	654	681	700	710	709	695	664	609	501	

tc +15, tsub 1 K

Evaporation		-40	-35	-30	-25	-20	-15	-10	-5	0	5	10
Distributor	0	1	1	1	1	1	1	1	1	1	1	1
	0.5	0.99	0.99	0.99	0.99	0.99	0.99	0.99	0.99	0.98	0.98	0.96
	1	0.99	0.99	0.99	0.99	0.98	0.98	0.98	0.98	0.97	0.95	0.91
	1.5	0.98	0.98	0.98	0.98	0.98	0.97	0.97	0.96	0.95	0.93	0.86
	2	0.98	0.97	0.97	0.97	0.97	0.96	0.96	0.95	0.94	0.91	0.81
	0	-	-	-	-	-	277	371	424	446	438	379

tc +15, tsub 1 K

Subcooling	1	2	4	6	8	10	15	20
Factor	1	1.02	1.06	1.10	1.13	1.17	1.26	1.34

Dimension and weight

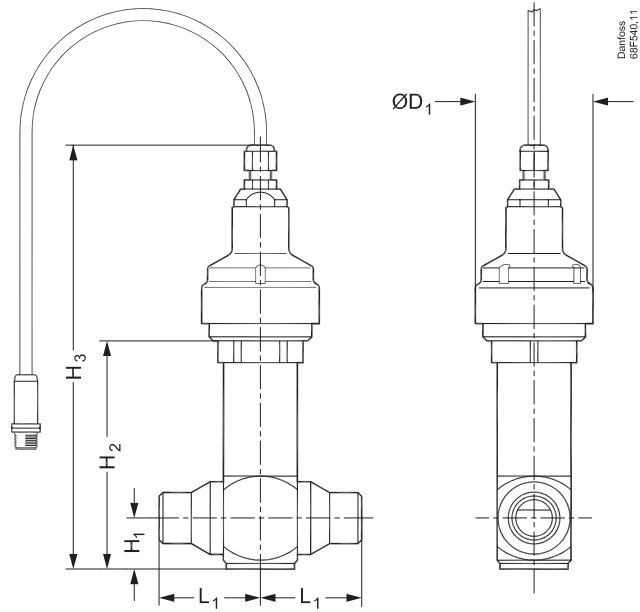

Type	H ₁		H ₂		H ₃		L ₁		ØD ₁		Weight	
	mm	in.	mm	in.	mm	in.	mm	in.	mm	in.	kg	lb.
CCM	26.2	1.0	120.0	4.7	225.0	8.9	53.0	2.1	62.0	2.4	1.8	4.0

For further information please contact Danfoss