

Data Sheet

Motor operated valve Type **ICMTS** with actuator Type **ICAD 600A-TS**

Designed to regulate the flow of transcritical gas or subcritical liquid from the gascooler in transcritical CO₂ systems



The ICMTS is a direct operated motorised valve driven by actuator type ICAD 600A-TS. The ICMTS is designed to regulate the flow of transcritical gas or subcritical liquid from the gascooler in transcritical CO₂ systems. The ICMTS can also be used for other control functions in CO₂ systems. The ICMTS valve is designed so that the opening and closing forces are balanced.

ICAD 600A-TS actuators can be controlled using the following signals:

- 0 – 20 mA
- 4 – 20 mA (default)
- 0 – 10 V
- 2 – 10 V

ICAD 600A-TS actuators can also operate an ICMTS valve as an On/Off function supported by a digital input.

The ICMTS valve can be operated manually via the ICAD 600A-TS actuator or via the Multi-function tool for ICMTS (see the [Ordering](#)).

The actuator type 600A-TS is designed specifically for ICMTS valves.

The ICAD 600A-TS is controlled via a modulating analogue signal (e.g. 4 – 20 mA / 2 – 10 V) or a digital ON/OFF signal. ICAD 600A-TS incorporates an advanced MMI (Man Machine Interface), including continuous display of Opening Degree, which gives the user a very advanced and flexible setup procedure that can meet many different applications. The ICMTS valve is typically controlled by the Danfoss EKC 326A controller.

Features

Valves

- Designed for high pressure CO₂ systems with applications for a maximum working pressure of 140 bar / 2030 psig.
- Applicable to R744 (CO₂)
- Direct coupled connections
- Connection types are DIN butt weld
- Non-alloyed quality steel
- Low weight and compact design
- Regulating cone ensures optimum regulating accuracy, particularly at part load
- Manual opening possible via ICAD 600A-TS or Multi-function tool
- The PTFE seat provides excellent valve tightness
- Magnet coupling - real hermetic sealing
- ICAD 600A-TS include encoder function that will provide a true valve position feedback to Danfoss controller or non-Danfoss control systems.

Actuator

- Specifically designed for ICMTS valve
- Advanced and high speed Digital Stepper Motor Technology
- Seven segment LCD display including three programming keys
- Valve opening degree can be observed continuously
- Can easily be configured to different applications on-site. (change speed, ON/OFF, modulating valve)
- Open – Close time: 3 seconds
- Modulating or ON/OFF operation
- Multiple speed selection during operation
- Logging of old alarms
- Password protection
- Control input signal: 4 – 20 mA, 0 – 20 mA, 0 – 10 V, 2 – 10 V
- Position feed back: 0 – 20 mA, 4 – 20 mA (ICMTS)
- 3 digital ON/OFF feedback
- Resolution: 20 micron/step (0.02 mm stroke pr. step)
- Total steps: 250
- Auto Calibration, Neutral zone
- In the event of a power failure, multiple fail safe options are possible. During power failure, ICAD 600A-TS can be selected to:
 - Close ICMTS
 - Open ICMTS
 - Stay in the position it was in, prior to power failure. Go to a specific ICMTS valve opening degree.
- Hermetic magnetic motor
- Enclosure: IP 67 (~NEMA 6)
- Approvals: CE, UL, CRN
- Connectors for easy installation and servicing
- Can be controlled by Danfoss EKC 326A controller and integrated into Danfoss ADAP-KOOL® system.

Function

ICMTS valve

The ICMTS motor valve is designed for use with ICAD 600A-TS.

The driving force from the actuator is transferred via a magnetic coupling (a) through the stainless steel top housing (b), thus eliminating the need for a packing gland. The rotational movement of the magnetic coupling (a) is transferred to a spindle (c) which in turn provides the vertical movement of the cone (d) and PTFE valve plate (e), to open and close the valve. The closing force of the actuator combined with the PTFE valve plate (e) and valve seat (f) provides an effective seal to prevent leakage across the valve port, when the valve is in the closed position. To prevent damage to the PTFE valve plate (e) and seat (f) from system debris, it is recommended to install a filter in the system.

Valve inlet pressure (P_1) acting on the underside of the PTFE valve plate (e) also passes through the hollow cone assembly (d) on to the top of the piston (g) and balances the pressure acting on the piston (g). Any trapped liquid across the throttle cone (d) is equalised down to the valve outlet without affecting the valve performance.

Figure 1: ICMTS

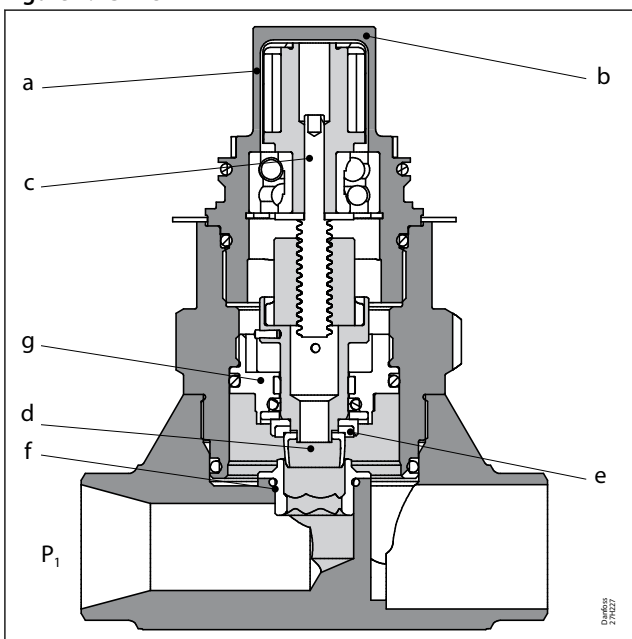

The actuators have a fully weather protected enclosure with none of the moving parts exposed to the environment.

The fast acting actuators and balanced valve design results in the valve being able to move from the fully closed to the fully open position in about 3 seconds.

The smallest cones (A33 and A) are log-shaped in order to provide optimum regulation at small capacities and high pressure differentials.

The first version of the ICMTS valve features V-shaped A cones. Please contact your local Danfoss sales company for further info.

Bigger cones (B and C) are V-shaped in order to provide an optimum regulating curve for higher capacities.

ICAD 600A-TS actuator

The design of ICAD 600A-TS is based on a digital stepper motor technology combined with an advanced MMI (Man Machine Interface), that gives excellent possibilities for having a high degree of flexibility with the same type of ICAD 600A-TS actuator.

The Opening Degree (0-100 %) of the actual ICMTS valve installed can be continuously observed on the ICAD 600A-TS display.

Motor operated valve, type ICMTS with actuator, type ICAD 600A-TS

The advanced menu system will allow several parameters to be adjusted to obtain the required function.

Many different parameters can be configured, among these:

- Modulating and ON/OFF control
- Analogue input
 - 0 – 20 mA or 4 – 20 mA
 - 0 – 10 V or 2 – 10 V
- Analogue output
 - 0 – 20 mA or 4 – 20 mA
- Automatic or manual control
- Change of ICMTS valve speed
- Automatic calibration
- Multiple Fail Safe set-up options during power cut

For service all Input and Output signals can be recalled and observed from the ICAD 600A-TS display.

A password protection has been linked to the parameter of entering the correct ICMTS valve to avoid unintentional and non-authorised operation.

The design of ICAD 600A-TS is based on a digital stepper motor technology combined with an advanced MMI (Man Machine Interface), that gives excellent possibilities for having a high degree of flexibility with the same type of ICAD 600A-TS actuator.

The Opening Degree (0-100 %) of the actual ICMTS valve installed can be continuously observed on the ICAD 600A-TS display.

The advanced menu system will allow several parameters to be adjusted to obtain the required function.

Many different parameters can be configured, among these:

- Modulating and ON/OFF control
- Analogue input
 - 0 – 20 mA or 4 – 20 mA
 - 0 – 10 V or 2 – 10 V
- Analogue output
 - 0 – 20 mA or 4 – 20 mA
- Automatic or manual control
- Change of ICMTS valve speed
- Automatic calibration
- Multiple Fail Safe set-up options during power cut

Application

ICMTS valve

Figure 2: Application

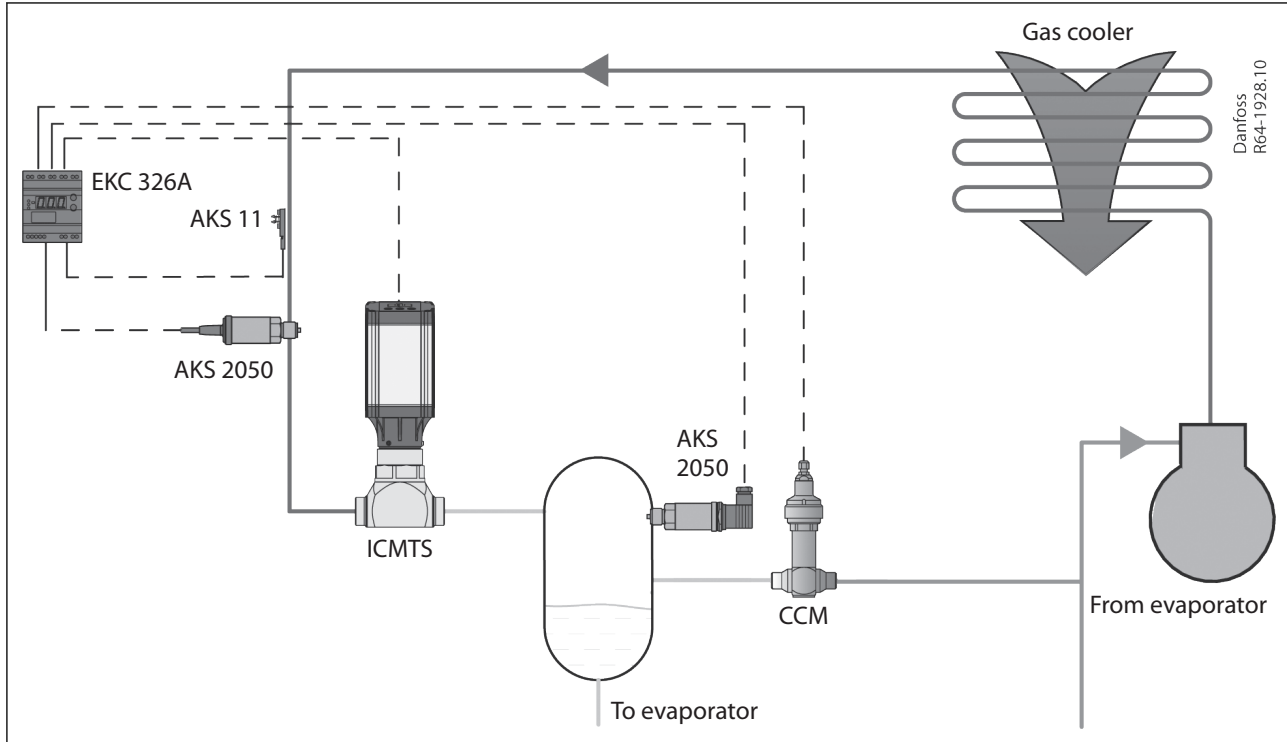

The ICMTS valve is developed for transcritical CO₂ applications. The ICMTS valve can be used in systems with flash gas bypass, parallel compression as well as in stand-alone application. The ICMTS valve can be used in transcritical and subcritical conditions.

The most typical application is with flash gas bypass.

Pressure optimisation is performed by the Danfoss EKC 326A controller and the ICMTS valve which is installed at the outlet of the gas cooler (see [Figure 2: Application](#)). This design provides the possibility to optimise gas cooler pressure and intermediate receiver pressure independently.

The pressure in the receiver is one important parameter, but the design of the receiver is also important. It typically acts as a liquid separator as well.

In order to keep the intermediate pressure low, flash gas is expelled through a gas bypass valve to the suction side of the compressor. The two phase mixture from the ICMTS valve has to be separated before gas enters the gas bypass.

Please refer to the Danfoss Application guide, DKRCE.PA.R1.A for more information on CO₂ systems.

Media

Refrigerants

Applicable to R744 (CO₂). ICMTS valves must not be used with flammable refrigerants. For further information, please contact your local Danfoss sales company.

New refrigerants

Danfoss products are continually evaluated for use with new refrigerants depending on market requirements.

When a refrigerant is approved for use by Danfoss, it is added to the relevant portfolio, and the R number of the refrigerant (e.g. R513A) will be added to the technical data of the code number. Therefore, products for specific refrigerants are best checked at store.danfoss.com/en/, or by contacting your local Danfoss representative.

Product specification

Technical data

ICMTS valve

Table 1: Technical data - Valve

Features	Specifications
Connections	ICMTS valves are available with DIN butt weld connections.
Design	Valve body and top cover material
Temperature range	Media: -60/+120 °C (-76/+248 °F)
Pressure	Max. working pressure: 140 bar g (2030 psig)
Surface protection	The external surface is treated in order to provide good corrosion protection Max. opening pressure differential (MOPD)ICMTS: 90 bar (1305 psi) The time it takes to move from Closed to Open position or in reverse order with maximum selected speed at ICAD 600A-TS is 3 seconds.

ICAD 600A-TS actuator

Table 2: Technical data - Actuator

Features	Specifications
Materials	Housing: Aluminium Top part of ICAD 600A-TS: PBT thermo plastic
Weight	ICAD 600A-TS: 1.2 kg (2.64 lb)
Temperature range (ambient)	-30 °C / +50 °C (-22 °F / 122 °F)
Enclosure	IP 67 (~NEMA 6)
Cable connection	Can be ordered with or without cables included. If ordered with cables: 2 cables in length of 1.5 m length (60 in.) with M12 connectors included
Supply cable	3 × 0.34 mm ² (3 × ~22 AWG) Ø4.8 mm (diameter 0.19")
Control cable	7 × 0.25 mm ² (7 × ~24 AWG) Ø6 mm (diameter 0.24")

Table 3: Electrical connections

Features	Specifications
Electrical data	Supply voltage is galvanic isolated from Input/Output
Supply voltage	Load: 24 V DC, + 10% / -15% ICAD 600A-TS: 1.2 A
Fail safe supply	Min. 19 V DC, max. 26.4 V DC Load: ICAD 600A-TS: 1.2 A
Battery capacity	For each open/closed cycle ICAD 600A-TS: Speed Parameter i04=100 (max. speed): 2 mAh Speed Parameter i04=1 (min. speed): 200 mAh
Analogue input	Current: 0/4 – 20 mA Load: 200 Ω Voltage: 0/2 – 10 V DC Load: 10 kΩ
Analogue output	Current: 0/4-20 mA Load: ≤ 250 Ω
Digital input	Digital ON/OFF input by means of volt-free contact (Signal/Telecom relays with gold-plated contacts recommended) – Voltage input used <ul style="list-style-type: none"> • ON: contact impedance < 50 Ω • OFF: contact impedance > 100 kΩ
Digital output	3 pcs. NPN transistor output External supply: 5 – 24 V DC (Same supply as for ICAD 600A- TS can be used, but please note that the galvanically isolated system will then be spoiled). Output load: 50 Ω Load: Max. 50 mA

Cable connection

Cable connection - Two 1.5 m (60 in) cables premounted

Motor operated valve, type ICMTS with actuator, type ICAD 600A-TS

Figure 3: Cable connection

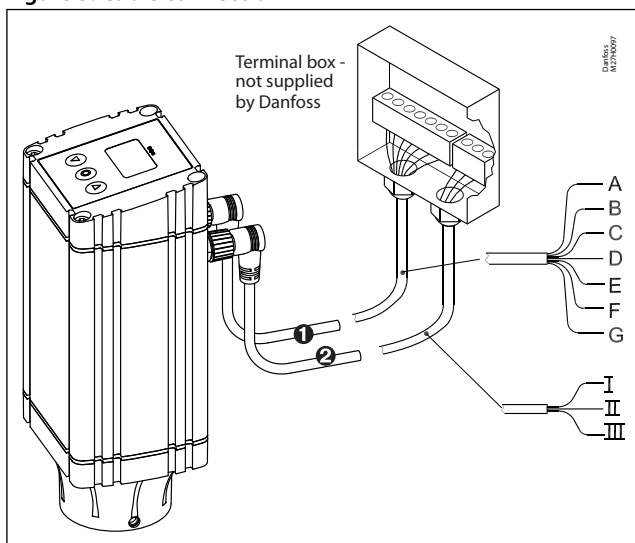

- | | |
|---|---------------|
| 1 | Control cable |
| 2 | Supply cable |

Figure 4: Rear view

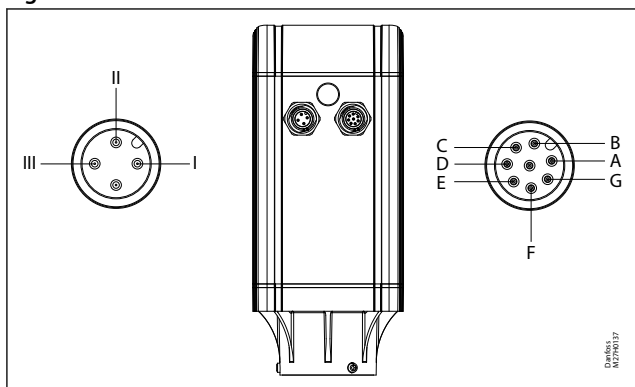

Table 4: Connection

Ref.	Colour	Charge	Description
8 pin male connector			
A	Black	-	Common Alarm
B	Brown	-	ICMTS fully open
C	Red	-	ICMTS fully closed
D	Orange	-	GND ground
E	Yellow	+	0/4 - 20 mA Input
F	Green	+	0/2 - 10 V Input
G	Blue	+	0/4 - 20 mA Output
4 pin male connector			
I	Black	+	Fail safe supply Battery / UPS ⁽¹⁾ 19 V DC
II	White	+	Supply voltage 24 V DC
III	Brown	-	

⁽¹⁾ Uninterruptable Power Supply

NOTE:

Colour code changed when compared to older colour wiring diagram.

Fail Safe supply options

Figure 5: ICAD 600A-TS



In the event of a power failure, multiple fail safe options are possible, provided that a ICAD-UPS or similar is used.

During power failure, ICAD 600A-TS can be selected to:

- Close ICMTS
- Open ICMTS
- Stay in the position it was in, prior to power failure
- Go to a specific ICMTS valve opening degree

See the [ICAD-UPS for ICMTS](#) for further information.

i NOTE:

A fail safe supply (battery or UPS) is required.

ICAD-UPS for ICMTS

Figure 6: ICAD-UPS



ICAD-UPS is designed for using with ICMTS valve.

In the event of power failure, there is a need to make sure that the ICMTS goes to a safe position. ICAD-UPS can be connected to the ICAD 600A-TS.

The solution of connecting ICMTS with ICAD 600A-TS to ICAD-UPS will give one of the following possibilities in the event of power failure:

Motor operated valve, type ICMTS with actuator, type ICAD 600A-TS

- close ICMTS
- open ICMTS
- stay
- go to a specific ICMTS Opening Degree

When power supply has been re-established the system will automatically return to normal operation.

Facts and features

- Industrial product
- Can support up to 8 pcs. of ICAD 600A-TS
- Integrated solution - battery and UPS
- Industrial approvals:
CE, UL, GL (Germanischer Lloyd)
- DIN rail mounting
 - LED indication
 - Green (Power ON)
 - Yellow (Flashing: charging, Constant: Buffer mode (Failsafe supply to ICAD 600A- TS))
 - Red (Battery fully discharged/Battery faulty)
- 24 V DC supply → Same transformer as for ICAD 600A-TS can be used. Only +0.5 A extra load on the transformer.
- Check of battery every 60 sec.
- Adjustable buffer time⁽¹⁾. (1, 2, 3, 5, 10, 15, 20, 30 or infinity) = Ensures longer battery life time.
- Forced remote shutdown in buffer mode via digital input
- 3 digital volt free relay change over contacts for signals to PLC systems. (Power OK, Buffer mode (failsafe supply to ICAD 600A-TS), Alarm).

Code number: **027H0182**

For further information, please see the instruction AN000086416706.

Applications

Figure 7: Separate 24 V DC transformer for both ICAD-UPS and ICAD 600A-TS

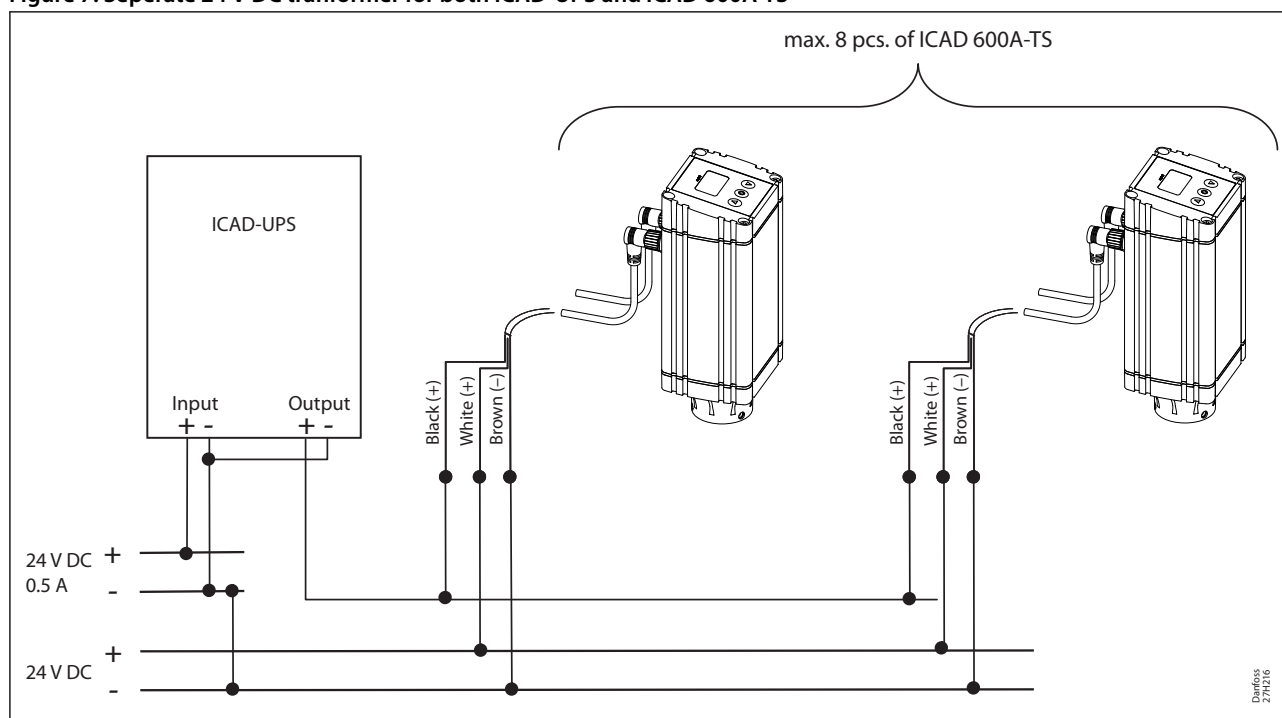

¹ Buffer time is defined as the period where ICAD 600A-TS is only powered from the ICAD-UPS (i.e. not from main supply). On ICAD-UPS there is an adjustable buffer time setting (1, 2, 3, 5, 10, 15, 20, 30 min. or infinity). If set to 3, ICAD-UPS will switch off power to connected ICAD 600A-TS, 3 minutes after the power failure occurs. This ensures that the internal battery inside ICAD-UPS does not fully discharge.

Figure 8: One 24 V DC transformer for ICAD-UPS and ICAD 600A-TS

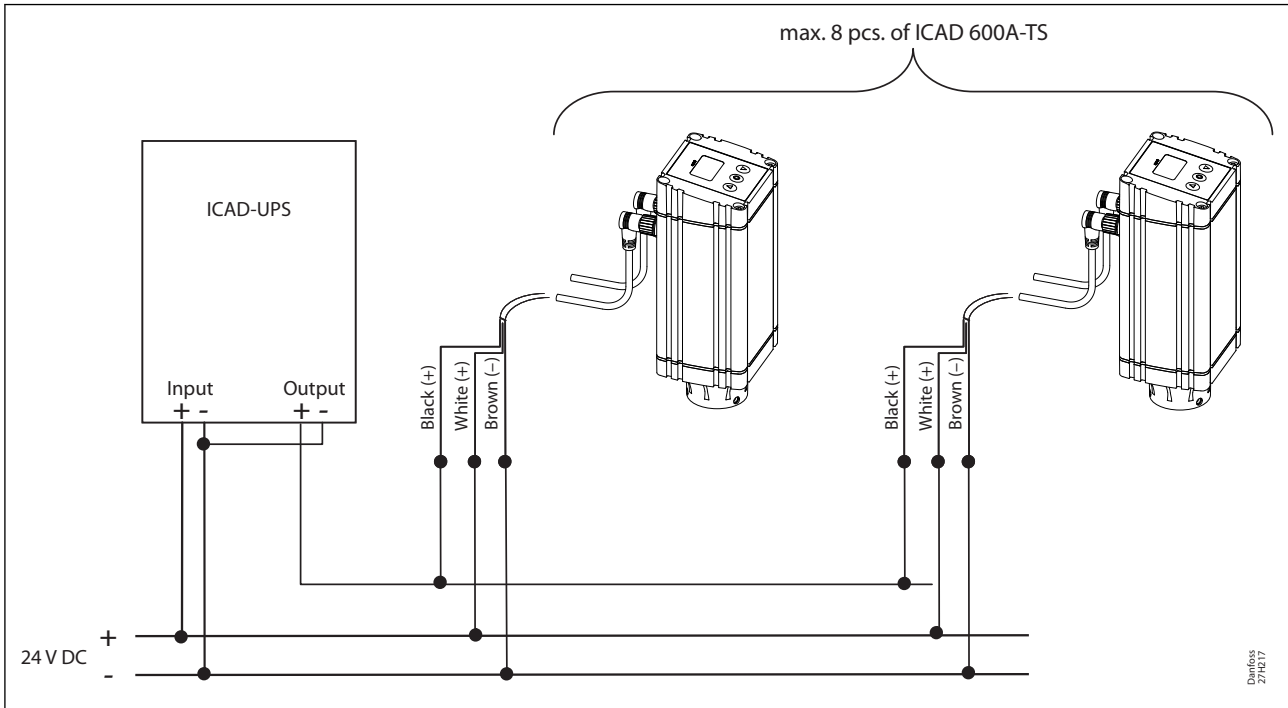

Material specification

Figure 9: Material specification

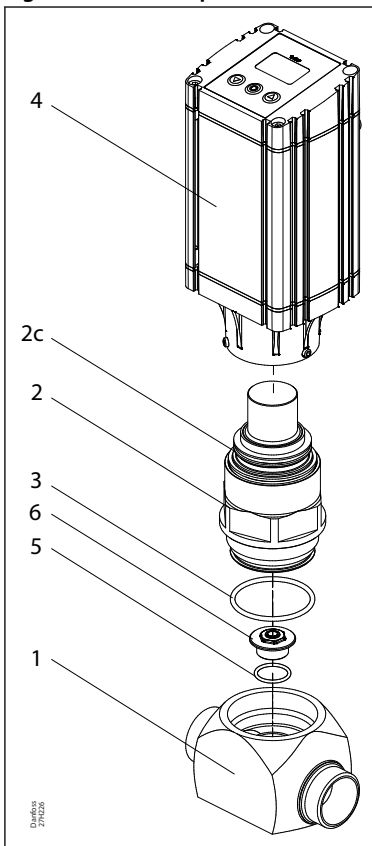

Table 5: Material specification

No.	Part	Material	EN	ASTM
1	Housing	Low temperature steel	S235J2, EN10025	A515
2	Top cover / function module	Low temperature steel	S355J2, EN10025	LCC, A352
2c	O-ring	Chloroprene (Neoprene)		
3	O-ring	Chloroprene (Neoprene)		
4	Actuator			
5	O-ring	Chloroprene (Neoprene)		
6	Seat	Stainless steel		

ICMTS capacities

It is relatively complex to correctly size a valve for transcritical applications, especially as the mass flow of the refrigerant changes, drastically moving from transcritical to subcritical conditions. At the same time, temperature variations in the intermediate vessel downstream of the valve, will not significantly affect the sizing the valve.

It is recommended to calculate the ICMTS valve using Danfoss DIRcalc™ software following these steps:

- Calculate the ICMTS valve as an expansion valve in the liquid line with the following conditions: Tcond = +30 °C, T_{evap} = temperature in the intermediate vessel, 0 K subcooling.
- Check the selected valve for the winter conditions: e.g. Tcond = +15 °C with 5 K subcooling
- Possible part load of the system at Tcond = +30 °C, T_{evap} = temperature in the intermediate vessel, 10 K subcooling. (night operation or the smallest capacity step of the power pack). The part load of the valve should be above 10%.

Quick capacity selection could be done using the following table:

Table 6: 0 K subcooling in the subcritical mode

	+15/+5 °C [kW]	+30/+5 °C [kW]	+38 (100 bar)/+5 °C [kW]
ICMTS 20-A33	16.7	16.1	25
ICMTS 20-A	50	48	75
ICMTS 20-B	291	278	423
ICMTS 20-C	479	454	675

Table 7: 5 K subcooling in the subcritical mode

	+15/+5 °C [kW]	+30/+5 °C [kW]	+38 (100 bar)/+5 °C [kW]
ICMTS 20-A33	18.5	23	25
ICMTS 20-A	56	69	75
ICMTS 20-B	325	400	423
ICMTS 20-C	540	655	675

Table 8: 10 K subcooling in the subcritical mode

	+15/+5 °C [kW]	+30/+5 °C [kW]	+38 (100 bar)/+5 °C [kW]
ICMTS 20-A33	20.4	26.5	25
ICMTS 20-A	61	80	75
ICMTS 20-B	355	470	423
ICMTS 20-C	585	760	675

Please contact your local Danfoss sales office if you need assistance in your selection of ICMTS valves.

Dimensions

Figure 10: Dimensions

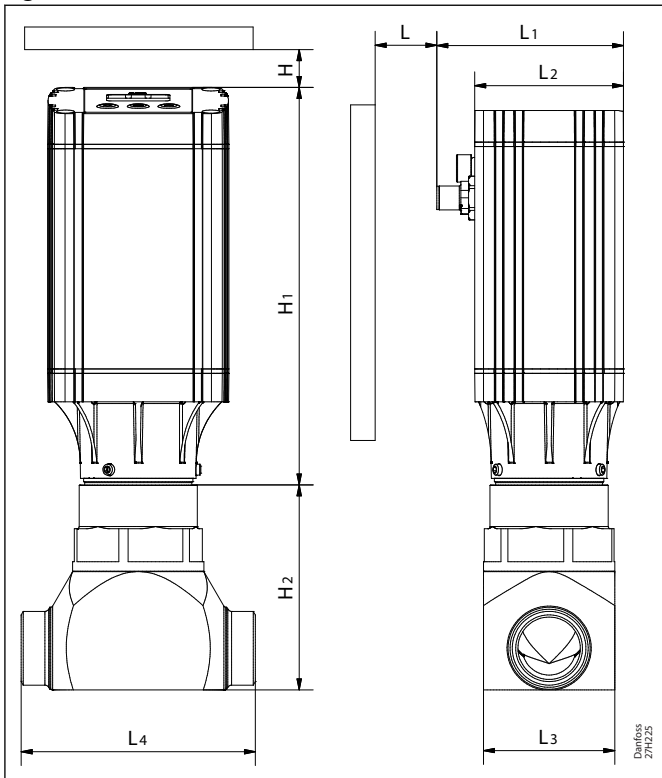

Table 9: Dimension

Connection		H	H ₁	H ₂	L ⁽¹⁾	L ₁	L ₂	L ₃	L ₄	Weight ICMTS incl. ICAD 600A-TS
25 D (1 in.)	mm	40	195	94	65	86	68	60	107	3.3 kg
	in.	1.58	7.68	3.7	2.56	3.39	2.68	2.36	4.21	6 lb.

⁽¹⁾ Include space for ICAD Protection cap.

NOTE:

Weight is approximated only.

Connections

Figure 11: Butt weld DIN (EN 10220)

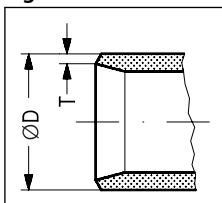

Table 10: Butt weld DIN (EN 10220)

Size mm	Size in.	OD mm	T mm	OD in.	T in.
25	-1	33.7	2.6	1.327	0.103

General operation

ICAD 600A-TS is equipped with an MMI (Man Machine Interface) from which it is possible to monitor and change the setting of parameters to adapt the ICAD 600A-TS and the corresponding ICMTS to the actual refrigeration application.

Figure 12: Display

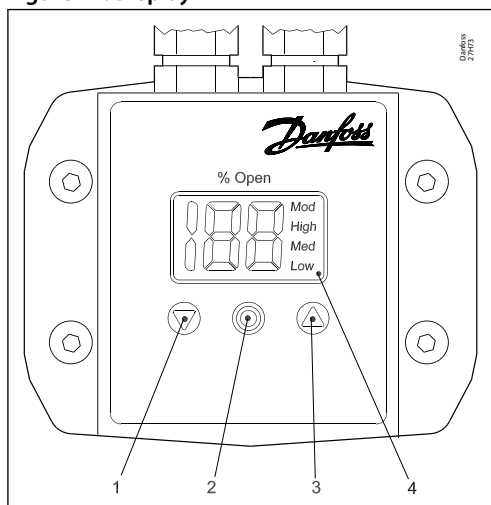

1	"Down" arrow push button
2	Enter
3	"Up" arrow push button
4	Display

The setting of parameters is managed by means of the integrated ICAD 600A-TS MMI (see [Figure 12](#) and [Figure 13](#)) and consists of:

- "Down" arrow push button ([Figure 12](#), pos. 1)
 - Decreases parameter number by 1 at each activation.
- "Up" arrow pushbutton ([Figure 12](#), pos. 3)
 - Increases parameter number by 1 at each activation.
- Enter push button ([Figure 12](#), pos. 2)
 - Gives access to the Parameter list by keeping the push button activated for 2 seconds. A Parameter list example is shown below (parameter **j08**, see [Figure 14](#)).
 - Gives access to change a value once the Parameter list has been accessed
 - Acknowledge and save change of value of a parameter.
 - To exit from the Parameter list and return to the display of Opening Degree (OD), keep the Enter button activated for 2 seconds.
- Display ([Figure 12](#), pos. 4)
 - The Opening Degree (OD) 0 - 100 % of the ICMTS valve is normally displayed. When the push buttons are not activated for 20 seconds, the display will return to OD (see [Figure 15](#)).
 - Displays the parameter
 - Displays the actual value of a parameter
 - Displays the function status by means of text ([Figure 12](#), pos. 4)
 - **Mod** represents that ICAD 600A-TS is positioning the ICMTS valve according to an analogue input signal (Current or Voltage).
 - **Low** represents that ICAD 600A-TSS is operating the ICMTS valve like an ON/OFF solenoid valve with low speed according to a digital input signal.
 - **Med** represents that ICAD 600A-TS is operating the ICMTS valve like an ON/OFF solenoid valve with medium speed according to a digital input signal.
 - **High** represents that ICAD 600A-TS is operating the ICMTS valve like an ON/OFF solenoid valve with high speed according to a digital input signal (see [Figure 16](#)).

Figure 13: Display

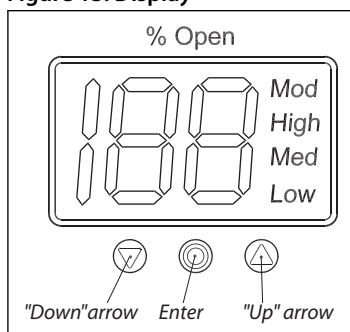

Figure 14: Parameter

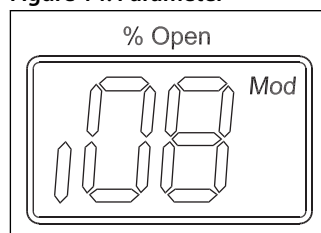

Figure 15: Display - OD

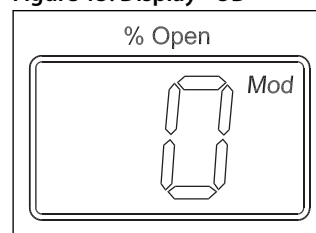
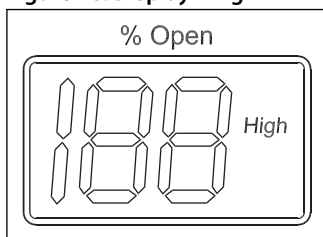

Figure 16: Display - High



Alarms

Table 11: Alarms

Description	ICAD alarm text	Definition of event	Comments
No Valve type selected	A1	Alarm ON	At start-up A1 will be displayed
Controller fault	A2	Alarm ON	Internal fault inside electronics. Carry out: 1. Power OFF and Power ON If A2 still active. 2. Make a Reset to factory setting If A2 still active. Return ICAD to Danfoss
AI input error	A3	Alarm ON	Not active if i01 = 2, or i02 = 2 When i03 = 1 and AI A > 22 mA When i03 = 2 and AI A > 22 mA or AI A < 2 mA When i03 = 3 and AI A > 12 V When i03 = 4 and AI A > 12 V or AI A < 1 V
Low voltage of fail safe Supply	A4	Alarm ON	If 5 V < fail safe supply < 18 V. Enabled by i08
Check supply to ICAD	A5	Alarm ON	If supply voltage < 18 V
Calibration extended failed	A6	Alarm ON	Check valve type selected. Check presence of foreign body internally in ICMTS valve
Internal temperature alarm	A7	Alarm ON	Temperature for stepper motor component too high. Ventilate/lower ambient ICAD temperature
	A8	Alarm ON	Temperature for stepper motor component too high. Ventilate/lower ambient ICAD temperature.
Valve locked	A9	Alarm ON	Only active if i16 = 1 If the valve is locked in more than 15 seconds. ICMTS stopped and hold position A9 flashing in display A9 alarm can only be reset by Power OFF/ON of ICAD

If an alarm has been detected, the ICAD 600A-TS display (see [Figure 12: Display](#)) will alternate between showing Actual alarm and Present Opening Degree.

If more than one alarm is active at the same time, the alarm with the highest priority will take preference. **A1** has the highest priority, **A5** the lowest.

Any active alarm will activate the Common Digital Alarm Output (Normally Open).

All alarms will automatically reset themselves when they physically disappear.

Old alarms (alarms that have been active, but have physically disappeared again) can be found in parameter **i11**.

Parameter list

Valid from: (**i58:11**, **i59:36**) and onwards

NOTE:

The first parameter to be entered shall be: **i26**

Motor operated valve, type ICMTS with actuator, type ICAD 600A-TS

Table 12: Parameter list

Description	ICAD parameter	Min	Max	Factory Setting	Stored	Unit	Password	Comments
OD (Opening degree)	-	0	100			%	-	ICMTS valve Opening Degree is displayed during normal operation. Running display value (see i01 , i05).
Main Switch	i01	1	2	1	√	-	No	Internal main switch 1. Normal operation 2. Manual operation. Valve Opening Degree will be flashing. With the down arrow and the up arrow push buttons the OD can be entered manually.
Mode	i02	1	2	1	√	-	No	Operation mode 1. Modulating – ICMTS positioning according to Analog Input (see i03) 2. ON/OFF - operating the ICMTS valve like an ON/OFF solenoid valve controlled via Digital Input. See also i09 . 3. Neutralzone / 3 point control. Increase/Decrease Opening Degree by Digital Input.
AI signal	i03	1	4	2	√	-	No	Type of AI signal from external controller 1. 0 – 20 mA 2. 4 – 20 mA 3. 0 – 0 V 4. 2 – 10 V
Speed In Modulating Mode Opening/closing speed In ON/OFF Mode Opening speed	i04	1	100	50/ 100	√	-	No	Speed can be decreased. Max. speed is 100 % - Not active in manual operation (i01 = 2) If i26 = 1 - 3 then factory setting = 100 If i26 = 4 - 9 then factory setting = 50 If ICMTS is opening and (i04 <= 33) or ICMTS is closing and (i14 <= 33) => Low is displayed. If ICMTS is opening and (33 < i04 <= 66) or ICMTS is closing and (33 < i14 <= 66) => Med is displayed. If ICMTS is opening and (i04 >= 67) or ICMTS is closing and (i14 >= 67) => High is displayed"
Automatic calibration	i05	0	2	0		-	No	Not active before i26 has been operated. Always auto reset to 0. CA will flash in the display during calibration, if Enter push button has been activated for two seconds 0: No Calibration 1: Normal forced calibration - CA flashing slowly 2: Extended calibration – CA flashing rapidly
AO signal	i06	0	2	2	√	-	No	Type of AO signal for ICV valve position 0: No signal 1: 0-20 mA 2: 4-20 mA
Failsafe	i07	1	4	1	√	-	No	Define condition at power cut and fail safe supply is installed. 1: Close valve 2: Open Valve 3: Maintain valve position 4: Go to OD given by i12
Fail safe supply	i08	0	1	0	√		Yes	Fail safe supply connected and enable of A4 alarm 0: No 1: Yes
DI function	i09	1	2	1	√		No	Define function when DI is ON (short circuited DI terminals) when i02 = 2 1: Open ICMTS valve (DI = OFF => Close ICMTS valve) 2: Close ICMTS valve (DI = OFF => Open ICMTS valve)
Password	i10	0	199	0		-	-	Enter number to access password protected parameters: i26 Password = 11
Old Alarms	i11	A1	A99	-		-	No	Old alarms will be listed with the latest shown first. Alarm list can be reset by means of activating down arrow and up arrow at the same time for 2 seconds.
OD at power cut.	i12	0	100	50	√		No	Only active if i07 = 4 If fail safe supply is connected and power cut occurs, the ICMTS will go to the specified OD.
Inverse operation	i13	0	1	0	√		No	When i02 = 1 0: Increasing Analog Input signal => Increasing ICMTS Opening Degree 1: Increasing Analog Input signal => Decreasing ICMTS Opening Degree When i02 = 3 0: DI1 = ON, DI2 = OFF => Increasing ICMTS Opening Degree. DI1 = OFF, DI2 = ON => Decreasing ICMTS Opening Degree DI1 = DI2 = OFF => ICAD/ICMTS maintain current position DI1 = DI2 = ON => ICAD/ICMTS maintain current position 1: DI1 = ON, DI2 = OFF => Decreasing ICMTS Opening Degree DI1 = OFF, DI2 = ON => Increasing ICMTS Opening Degree DI1 = DI2 = OFF => ICAD/ICMTS maintain current position DI1 = DI2 = ON => ICAD/ICMTS maintain current position

Motor operated valve, type ICMTS with actuator, type ICAD 600A-TS

Description	ICAD parameter	Min	Max	Factory Setting	Stored	Unit	Password	Comments
In ON/OFF Mode Closing speed	i14	0	100	50/ 100	√	-	No	See i04. If i26= 1 - 3 then factory setting = 100 If i26= 4 - 9 then factory setting = 50
Manual set point	i15	0	100	0			No	When i01= 2, i15 determine the start up value.
Encoder operation	i16	0	1	0/1	√		Yes	NB: Password protected. Password = 7 If i26 = 1 - 3 then factory setting = 0 If i26 = 4 - 6 then factory setting = 0 If i26 = 7 - 9 then factory setting = 1 0: Encoder disabled. Means ICAD operation as ICAD 600A-TS 1: Encoder enabled
Forced closing when ICMTS valve Opening Degree < 3%	i17	0	1	0	√	-	No	Enable/Disable forced closing 0: When ICMTS valve Opening Degree < 3% it will be forced to close regardless of requested ICMTS valve Opening Degree 1: When ICMTS valve Opening Degree < 3% no forced to closing will take place
ICMTS configuration	i26	0	9	0	√		Yes	NB: Password protected. Password = 11 0: No valve selected. Alarm A1 will become active. 1: ICMTS 20 with ICAD 600A-TS

Table 13: Service

Description	ICAD parameter	Min	Max	Factory Setting	Stored	Unit	Password	Comments
OD %	i50	0	100	-		%	-	ICMTS valve Opening Degree
AI [mA]	i51	0	100	-		mA	-	AI signal
AI [V]	i52	0	100	-		V	-	AI signal
AO [mA]	i53	0	100	-		mA	-	A0 signal
DI	i54	0	1	-		-	-	DI signals. Depending of i02 If i02 = 2, one digits are shown. 0: DI1 = OFF 1: DI1 = ON If i02 = 3, two digits are shown. 00: DI1 = OFF, DI2 = OFF 10: DI1 = ON, DI2 = OFF 01: DI1 = OFF, DI2 = ON 11: DI1 = ON, DI2 = ON
DO Close	i55	0	1	-		-	-	DO Closed status. ON when OD < 3 %
DO Open	i56	0	1	-		-	-	DO Open status. ON when OD > 97 %
DO Alarm	i57	0	1	-		-	-	DO alarm status. ON when a Alarm is detected
Display mP SW ver.	i58	0	100	-		-	-	Software version for display microprocessor
Motor mP SW ver.	i59	0	100	-		-	-	Software version for motor microprocessor

Reset to factory setting:

1. Remove the power supply
2. Activate down arrow and up arrow push buttons at the same time
3. Connect the power supply
4. Release down arrow and up arrow push buttons
5. When the display on ICAD (see [Figure 12: Display](#)) is alternating between showing: **CA** and **A1** the factory resetting is complete.

Ordering

Table 14: Ordering

Type	Code number
ICMTS	
ICMTS 20-A33	027H1084
ICMTS 20-A	027H1085
ICMTS 20-B66	027H1093
ICMTS 20-B	027H1086
ICMTS 20-C	027H1087
ICAD 600A-TS	
ICAD 600A-TS with cables	027H9078
ICAD 600A-TS without cables	027H9123

Accessories

Figure 17: Valve orifice

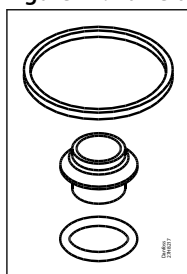

Table 15: Service kit 1 - valve orifice

Type	Code no.
Gasket kit with orifice for B and C cones	027H1192
Gasket kit with orifice for A33 and A (new design) cones	027H1193

Figure 18: ICMTS top part

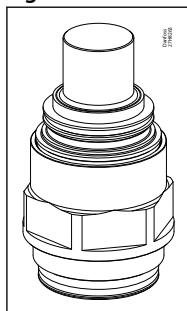
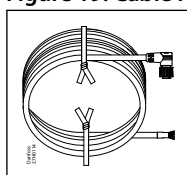

Table 16: Service kit 2 – Top part with cone complete

Type	Code no.
ICMTS 20-A33 top part with cone and orifice kit	027H1088
ICMTS 20-A top part with cone and orifice kit	027H1080
ICMTS 20-B66 top part with cone and orifice kit	027H1094
ICMTS 20-B top part with cone and orifice kit	027H1081
ICMTS 20-C top part with cone and orifice kit	027H1082

Figure 19: Cable for ICAD 600A-TS



Motor operated valve, type ICMTS with actuator, type ICAD 600A-TS

Table 17: Cable for ICAD 600A-TS

Cable length	Code no.
Cable set 1.5 m, female	027H0426
Cable set 10 m, female	027H0427

Figure 20: Connectors for ICAD 600A-TS

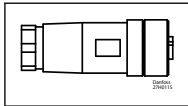

Table 18: Connectors for ICAD 600A-TS

Connector type	Code no.
Two Female Connectors with screw terminals: <ul style="list-style-type: none"> • connector for power • connector for control signals 	027H0430

**Figure 21:
ICAD-UPS**



Table 19: ICAD-UPS

Type	Code no.
ICAD-UPS	027H0182

**Figure 22:
Multi-function
tool**



Table 20: Multi-function tool

Type	Code no.
Multi-function tool	027H0181

Figure 23: ICAD 600A-TS Protection Cap

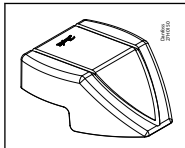
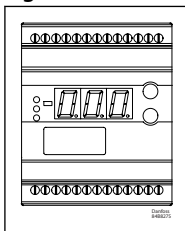

Table 21: ICAD 600A-TS Protection Cap

Type	Code no.
ICAD 600A-TS Protection Cap	027H0431

Figure 24: EKC 326A



Motor operated valve, type ICMTS with actuator, type ICAD 600A-TS

Table 22: EKC 326A

Type	Code no.
EKC 326A	084B7252

Table 23: Technical data - EKC 326A

Features	Specifications
Supply voltage	24 V AC +/-15% 50/60 Hz (the supply voltage is galvanically separated from the input and output signals)
Power consumption	Controller 8 VA
Input signal	Pressure transmitter Ratiometric, AKS 2050
	Digital input from external contact function
	Voltage signal 0 – 10 V Signal range = 2 – 10 V
Sensor input	1 pcs. Pt 1000 ohm
Alarm relay	1 pcs. SPST 250 V AC AC-1: 4 A (ohmic) AC-15: 3 A (inductive)
Actuator	ICAD 600A-TS mounted on ICMTS Voltage signal 0 – 10 mA
	CCM Step motor
Data communication	Possible to connect a data communication module type AKA 174
Environments	-10 – +55°C, during operations -40 – +70°C, during transport
	20 – 80% Rh, not condensed
	No shock influence / vibrations
Enclosure	IP 20
Weight	300 g
Mounting	DIN rail
Display	LED, 3 digits
Terminals	max. 2.5 mm ² multicore
Approvals	EMC acc. EN 61000-6-3 and EN 61000-6-2 LVD acc. EN 60730-1 and EN 60730-2-9

Figure 25: AKS 2050

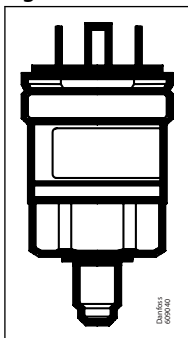

Table 24: AKS 2050

Operating range	Code no.
-1 – 59 bar	060G5750
-1 – 99 bar	060G5751
-1 – 159 bar	060G5752

Table 25: Technical data - AKS 2050

Features	Specifications
Operating range	as mentioned above
Permissible working pressure (PB)	250 bar
Compensated temperature range	0 – 80 °C
Connection	G 3/8 A 2) - Thread ISO 228/1 - G 3/8 A (BSP).

Figure 26: Connecting cable

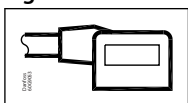

Table 26: Connecting cable

Cable	Code no.
Connecting plug with 5 m cable (a pressure transducer with the cap gets a IP67 rating)	060G1034

Figure 27: Plug Pg9

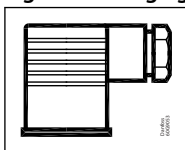

Table 27: Plug Pg9

Cable	Code no.
Plug Pg9	060G0008

Figure 28: AKS 11

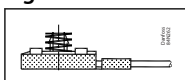

Table 28: AKS 11

Cable type	Code no.
Cable length: 3.50 m	084N0003
Cable length: 5.50 m	084N0005
Cable length: 8.50 m	084N0008

Table 29: Technical data - AKS 11

Features	Specifications
Max. ambient temperature	100 °C
Cable type	PVC
Electrical connection	Cable
Measuring range	-50 - 100 °C
Resistance value	1 x Pt 1000
Tolerance	EN 60751 Class B
Wires	2 pcs.

For selection of CCM motorised valves for CO₂ gas bypass application please see AI213386426013.

Certificates, declarations, and approvals

The list contains all certificates, declarations, and approvals for this product type. Individual code number may have some or all of these approvals, and certain local approvals may not appear on the list.

Some approvals may change over time. You can check the most current status at danfoss.com or contact your local Danfoss representative if you have any questions.

Table 30: ICMTS

File name	Document type	Document topic	Approvals Authority
033F0691.AE	Manufacturers Declaration	RoHS	Danfoss
033F0686.AH	Manufacturers Declaration	PED	Danfoss

Table 31: ICAD 600A-TS

File name	Document type	Document topic	Approvals Authority
E258350	Electrical - Safety Certificate	-	UL

Online support

Danfoss offers a wide range of support along with our products, including digital product information, software, mobile apps, and expert guidance. See the possibilities below.

The Danfoss Product Store



The Danfoss Product Store is your one-stop shop for everything product related—no matter where you are in the world or what area of the cooling industry you work in. Get quick access to essential information like product specs, code numbers, technical documentation, certifications, accessories, and more.

Start browsing at store.danfoss.com.

Find technical documentation



Find the technical documentation you need to get your project up and running. Get direct access to our official collection of data sheets, certificates and declarations, manuals and guides, 3D models and drawings, case stories, brochures, and much more.

Start searching now at www.danfoss.com/en/service-and-support/documentation.

Danfoss Learning



Danfoss Learning is a free online learning platform. It features courses and materials specifically designed to help engineers, installers, service technicians, and wholesalers better understand the products, applications, industry topics, and trends that will help you do your job better.

Create your Danfoss Learning account for free at www.danfoss.com/en/service-and-support/learning.

Get local information and support



Local Danfoss websites are the main sources for help and information about our company and products. Find product availability, get the latest regional news, or connect with a nearby expert—all in your own language.

Find your local Danfoss website here: www.danfoss.com/en/choose-region.

Spare Parts



Get access to the Danfoss spare parts and service kit catalog right from your smartphone. The app contains a wide range of components for air conditioning and refrigeration applications, such as valves, strainers, pressure switches, and sensors.

Download the Spare Parts app for free at www.danfoss.com/en/service-and-support/downloads.

Coolselector®2 - find the best components for you HVAC/R system



Coolselector®2 makes it easy for engineers, consultants, and designers to find and order the best components for refrigeration and air conditioning systems. Run calculations based on your operating conditions and then choose the best setup for your system design.

Download Coolselector®2 for free at coolselector.danfoss.com.

Danfoss A/S

Climate Solutions • danfoss.com • +45 7488 2222

Any information, including, but not limited to information on selection of product, its application or use, product design, weight, dimensions, capacity or any other technical data in product manuals, catalogues descriptions, advertisements, etc. and whether made available in writing, orally, electronically, online or via download, shall be considered informative, and is only binding if and to the extent, explicit reference is made in a quotation or order confirmation. Danfoss cannot accept any responsibility for possible errors in catalogues, brochures, videos and other material. Danfoss reserves the right to alter its products without notice. This also applies to products ordered but not delivered provided that such alterations can be made without changes to form, fit or function of the product.

All trademarks in this material are property of Danfoss A/S or Danfoss group companies. Danfoss and the Danfoss logo are trademarks of Danfoss A/S. All rights reserved.