

Data Sheet

Evaporator pressure regulator
Type **KVP**

Maintains a constant evaporating pressure



The KVP is mounted in the suction line after the evaporator and is used to:

1. Maintain a constant evaporating pressure and thereby a constant surface temperature on the evaporator. The regulation is modulating. By throttling in the suction line, the amount of refrigerant gas is matched to the evaporator load.
2. Protect against an evaporating pressure that is too low (e.g. as protection against freezing in a water chiller). The regulator closes when the pressure in the evaporator falls below the set value.
3. Differentiate between the evaporating pressures in two or more evaporators in systems with one compressor.

Features

- Accurate, adjustable pressure regulation
- Wide capacity and operating range
- Pulsation damping design
- Stainless steel bellows
- Compact angle design for easy installation in any position
- "Hermetic" brazed construction
- 1/4 in. Schrader valve for pressure testing
- Available with flare and ODF solder connections
- KVP 12 – KVL 22: may be used in the following EX range: Category 3 (Zone 2)

Functions

Figure 1: Design/Function for KVP

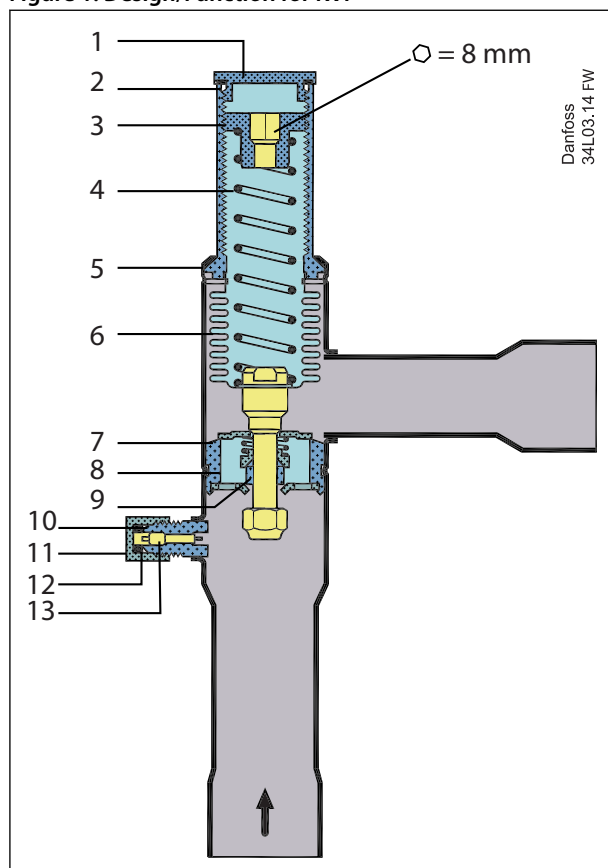

1	Protective cap
2	Gasket
3	Setting screw
4	Main spring
5	Valve body
6	Equalization bellows
7	Valve plate
8	Valve seat
9	Damping device
10	Pressure gauge connection
11	Cap
12	Gasket
13	Insert

The evaporator pressure regulator, type KVP opens on a rise in pressure on the inlet side, i.e. when the pressure in the evaporator exceeds the set value.

Type KVP regulates inlet pressure only. Pressure variations on the outlet side of the regulator do not affect the degree of opening as the valve is equipped with equalization bellows (6).

The bellows have an effective area corresponding to that of the valve seat neutralising any affect to the setting.

The KVP is also equipped with a damping device (9) providing protection against pulsations which can normally arise in a refrigeration system.

The damping device helps to ensure long life for the regulator without impairing regulation accuracy.

Figure 2: P-band and Offset

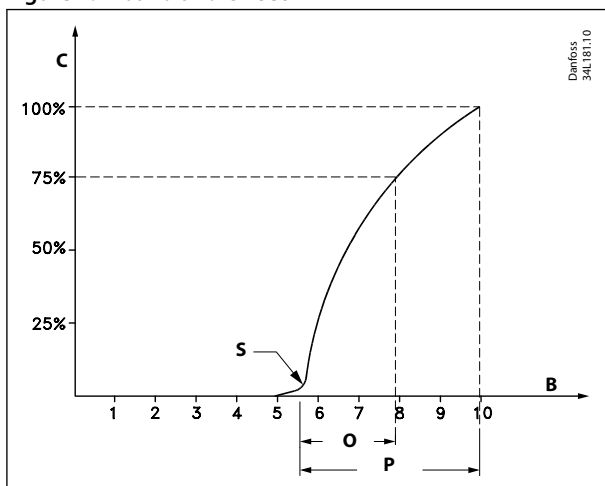

C	Capacity
B	bar
S	Setting
O	offset
P	P- band

Proportional band

The proportional band or P-band is defined as the amount of pressure required to move the valve plate from a closed to a fully open position

Example

If the valve is set to open at 4 bar and the valve P-band is 1.7, the valve will provide maximum capacity when the inlet pressure reaches 5.7 bar.

Offset

The offset is defined as the permissible pressure variation in evaporator pressure (temperature). It is calculated as the difference between the required working pressure and the minimum allowable pressure.

The offset is always a part of the P-band.

Example with R22

A working temperature of 5 °C ~ 4.9 bar is required, and the temperature must not drop below 0.5 °C ~ 4.1 bar. The offset will then be 0.8 bar.

When selecting a valve, be sure to correct the evaporator capacity based on the required offset.

Product specification

Technical data

Table 1: Technical data for KVP

Features	Description
Refrigerants	R22, R134a, R290 ⁽¹⁾ , R404A, R407A, R407C, R407F, R407H, R448A, R449A, R449B, R450A, R452A, R454A ⁽¹⁾ , R454C ⁽¹⁾ , R455A ⁽¹⁾ , R507, R513A, R515B, R516A, R600 ⁽¹⁾ , R600a ⁽¹⁾ , R1234ze(E) ⁽¹⁾ , R1234yf ⁽¹⁾ , R1270 ⁽¹⁾
Regulating range	0 – 5.5 bar Factory setting = 2 bar
Max. working pressure	PS/MWP PS = 18 bar
Max. test pressure	Pe = PS × 1.1 = 19.8 bar
Medium temperature range	-45 – 130 °C
Maximum P-band	KVP 12 – 22: 1.7 bar KVP 28 – 35: 2.8 bar
K _v -value ⁽²⁾ with offset 0.6 bar	KVP 12 – 22: 1.7 m ³ / h KVP 28 – 35: 2.8 m ³ / h
K _v -value ⁽²⁾ with maximum P-band	KVP 12 – 22: 2.5 m ³ / h KVP 28 – 35: 8.0 m ³ / h

⁽¹⁾ KVP 12 – KVP 22 only

⁽²⁾ The K_v value is the flow of water in [m³ / h] at a pressure drop across valve of 1 bar, ρ = 1000 kg / m³.

This product (KVP 12 – KVP 22) is evaluated for R290, R454A, R454C, R455A, R600, R600a, R1234ze(E), R1234yf, R2170 by ignition source assessment in accordance with standard EN ISO80079-36. Flare connections are only approved for A1 and A2L refrigerants.

For complete list of approved refrigerants, visit store.danfoss.com and search for individual code numbers, where refrigerants are listed as part of technical data.

Sizing

For optimum performance, it is important to select a KVP valve according to system conditions and applications.

The following data must be used when sizing a KVP valve:

- Refrigerant
- Evaporator capacity: Q_e in [kW]
- Evaporating temperature (required temperature): t_e in [°C]
- Minimum evaporating temperature: t_e in [°C]
- Liquid temperature ahead of expansion valve: t_l in [°C]
- Connection type: flare or solder
- Connection size in [in.]

Capacity tables

Table 2: Regulator capacity Q_e¹⁾ [kW] with offset = 0.6 bar, R134a

Type	Pressure drop in regulator Δp [bar]	Evaporating temperature t _e [°C]							
		-15	-10	-5	0	5	10	15	20
KVP 12 KVP 15 KVP 22	0.1	2	2.3	2.6	2.9	3.2	3.6	4	4.4
	0.2	2.8	3.1	3.6	4	4.5	5	5.5	6.1
	0.3	3.2	3.7	4.2	4.8	5.4	6	6.7	7.4
	0.4	3.6	4.1	4.8	5.4	6.1	6.8	7.6	8.4
	0.5	3.8	4.4	5.1	5.9	6.7	7.5	8.4	9.3
	0.6	3.9	4.7	5.5	6.3	7.1	8.1	9	10

Evaporator pressure regulator, type KVP

Type	Pressure drop in regulator Δp	Evaporating temperature t_e [°C]							
		[bar]	-15	-10	-5	0	5	10	15
KVP 28 KVP 35	0.1	4.1	4.6	5.2	5.8	6.5	7.2	7.9	8.7
	0.2	5.5	6.3	7.2	8	9	10	11.1	12.2
	0.3	6.5	7.5	8.5	9.6	10.8	12	13.4	14.8
	0.4	7.1	8.3	9.5	10.8	12.2	13.7	15.2	16.9
	0.5	7.6	8.9	10.3	11.8	13.4	15	16.8	18.6
	0.6	7.9	9.4	11	12.6	14.3	16.2	18.1	20.2

1) The capacities are based on liquid temperature ahead of expansion valve $t_l = 25$ °C regulator offset = 0.6 bar
Dry saturated gas ahead of regulator

Table 3: Regulator capacity Q_e ¹⁾ [kW] with offset = 0.6 bar, R404A/R507

Type	Pressure drop in regulator Δp	Evaporating temperature t_e [°C]							
		[bar]	-35	-30	-25	-20	-15	-10	-5
KVP 12 KVP 15 KVP 22	0.1	1.5	1.7	1.9	2.2	2.5	2.7	3	3.4
	0.2	2	2.3	2.7	3	3.4	3.8	4.3	4.7
	0.3	2.4	2.8	3.2	3.6	4.1	4.6	5.1	5.7
	0.4	2.6	3.1	3.5	4.1	4.6	5.2	5.9	6.5
	0.5	2.8	3.3	3.9	4.4	5.1	5.7	6.5	7.2
	0.6	2.9	3.5	4.1	4.7	5.4	6.2	7	7.8
KVP 28 KVP 35	0.1	3	3.4	3.9	4.4	4.9	5.5	6.1	6.8
	0.2	4	4.7	5.3	6.1	6.8	7.7	8.5	9.5
	0.3	4.7	5.5	6.4	7.2	8.2	9.2	10.3	11.5
	0.4	5.2	6.1	7.1	8.2	9.3	10.5	11.7	13.1
	0.5	5.5	6.6	7.7	8.9	10.2	11.5	13	14.5
	0.6	5.8	7	8.2	9.5	10.9	12.4	14	15.7

1) The capacities are based on liquid temperature ahead of expansion valve $t_l = 25$ °C regulator offset = 0.6 bar
Dry saturated gas ahead of regulator

Table 4: Regulator capacity Q_e ¹⁾ [kW] with offset = 0.6 bar, R407C

Type	Pressure drop in regulator Δp	Evaporating temperature t_e [°C]							
		[bar]	-25	-20	-15	-10	-5	0	5
KVP 12 KVP 15 KVP 22	0.1	2	2.3	2.6	2.9	3.2	3.6	4	4.4
	0.2	2.8	3.2	3.6	4	4.5	5	5.6	6.1
	0.3	3.3	3.8	4.3	4.8	5.4	6.1	6.7	7.4
	0.4	3.6	4.2	4.8	5.5	6.2	6.9	7.7	8.5
	0.5	3.9	4.5	5.2	6	6.8	7.6	8.5	9.4
	0.6	4	4.8	5.6	6.4	7.3	8.2	9.2	10.2
KVP 28 KVP 35	0.1	4.1	4.6	5.2	5.8	6.5	7.2	8	8.8
	0.2	5.6	6.4	7.2	8.1	9.1	10.1	11.2	12.3
	0.3	6.5	7.5	8.6	9.7	10.9	12.2	13.5	14.9
	0.4	7.2	8.4	9.7	11	12.4	13.8	15.4	17
	0.5	7.8	9.1	10.5	12	13.6	15.2	17	18.8
	0.6	8.1	9.6	11.2	12.8	14.6	16.4	18.4	20.4

1) The capacities are based on liquid temperature ahead of expansion valve $t_l = 25$ °C regulator offset = 0.6 bar
Dry saturated gas ahead of regulator

Table 5: Regulator capacity Q_e ¹⁾ [kW] with offset =0.6 bar, R448A

Type	Pressure drop in regulator Δp	Evaporating temperature t_e [°C]						
	[bar]	-25	-20	-15	-10	-5	0	5
KVP 12 KVP 15 KVP 22	0.1	2.1	2.4	2.6	3	3.3	3.6	4
	0.2	2.8	3.2	3.7	4.1	4.6	5.1	5.6
	0.3	3.4	3.9	4.4	4.9	5.5	6.2	6.8
	0.4	3.8	4.3	4.9	5.6	6.3	7	7.8
	0.5	4	4.7	5.4	6.1	6.9	7.7	8.6
	0.6	4.3	5	5.8	6.6	7.4	8.4	9.3
KVP 28 KVP 35	0.1	4.2	4.7	5.3	5.9	6.6	7.3	8.1
	0.2	5.7	6.5	7.3	8.2	9.2	10.2	11.3
	0.3	6.8	7.7	8.8	9.9	11.1	12.4	13.7
	0.4	7.5	8.7	9.9	11.2	12.6	14.1	15.6
	0.5	8.1	9.4	10.8	12.3	13.9	15.5	17.3
	0.6	8.5	10.0	11.6	13.2	14.9	16.8	18.7

¹⁾ The capacities are based on liquid temperature ahead of expansion valve $t_l = 25$ °C regulator offset = 0.6 bar
Dry saturated gas ahead of regulator

Table 6: Correction factors for liquid temperature t_l

t_l [°C]	10	15	20	25	30	35	40	45	50
R134a	0.86	0.9	0.95	1	1.06	1.12	1.19	1.28	1.37
R404A/R507	0.82	0.87	0.93	1	1.08	1.17	1.29	1.43	1.61
R407C	0.86	0.9	0.95	1	1.06	1.13	1.2	1.29	1.4
R448A	0.85	0.9	0.94	1	1.06	1.13	1.22	1.32	1.44

Table 7: Correction factors for offset

Offset [bar]	0.2	0.4	0.6	0.8	1	1.2	1.4
KVP 12	2.5	1.4	1	0.77	0.67	0.59	–
KVP 15	2.5	1.4	1	0.77	0.67	0.59	–
KVP 22	2.5	1.4	1	0.77	0.67	0.59	–
KVP 28	–	1.4	1	0.77	0.67	0.59	0.53
KVP 35	–	1.4	1	0.77	0.67	0.59	0.53

Valve selection

Example

When selecting the appropriate valve it may be necessary to convert the actual evaporator capacity using a correction factor. This is required when your system conditions are different than the table conditions. The selection is also dependant on the acceptable pressure drop across the valve.

The following example illustrates how this is done:

- Refrigerant: R134a
- Evaporator capacity: $Q_e = 4.2$ kW
- Evaporating temperature: $t_e = 5$ °C ~ 2.5 bar
- Minimum evaporating temperature: 1.4 °C ~ 2.1 bar
- Liquid temperature ahead of expansion valve: $t_l = 30$ °C
- Connection type: Solder
- Connection size: 5/8 in.

Step 1

Determine the correction factor for liquid temperature t_l ahead of expansion valve. From the Table 8: Correction factors for liquid temperature t_l a liquid temperature of 30 °C, R134a corresponds to a factor of 1.06.

Table 8: Correction factors for liquid temperature t_l

t_l [°C]	10	15	20	25	30	35	40	45	50
R134a	0.86	0.9	0.95	1	1.06	1.12	1.19	1.28	1.37
R404A/R507	0.82	0.87	0.93	1	1.08	1.17	1.29	1.43	1.61
R407C	0.86	0.9	0.95	1	1.06	1.13	1.2	1.29	1.4
R448A	0.85	0.9	0.94	1	1.06	1.13	1.22	1.32	1.44

Step 2

Determine the correction factor for the valve offset.

The offset is defined as the difference between the design evaporating pressure and the minimum evaporating pressure.

From the Table 9: Correction factors for offset, an offset of 0.4 bar (2.5 – 2.1) corresponds to a factor of 1.4.

Table 9: Correction factors for offset

Offset [bar]	0.2	0.4	0.6	0.8	1	1.2	1.4
KVP 12	2.5	1.4	1	0.77	0.67	0.59	–
KVP 15	2.5	1.4	1	0.77	0.67	0.59	–
KVP 22	2.5	1.4	1	0.77	0.67	0.59	–
KVP 28	–	1.4	1	0.77	0.67	0.59	0.53
KVP 35	–	1.4	1	0.77	0.67	0.59	0.53

Step 3

Corrected evaporator capacity is $Q_e = 1.06 \times 1.4 \times 4.2 = 6.2$ kW

Step 4

Now select the appropriate capacity table (R134a) and choose the column for an evaporating temperature of $t_e = 5$ °C.

Using the corrected evaporator capacity, select a valve that provides an equivalent or greater capacity at an acceptable pressure drop. KVP 12, KVP 15, KVP 22 delivers 6.4 kW at a 0.6 bar pressure drop across the valve.

KVP 28, KVP 35 delivers 6.2 kW at a 0.1 bar pressure drop across the valve.

Based on the required connection size of 5/8 in., the KVP 15 is the proper selection for this example.

Step 5

KVP 15, 5/8 in. solder connection: code no. 034L0029, see Table 11: Ordering for type KVP.

Valve selection based on capacity calculation

As for extended capacity calculations and valve selection based on capacities and refrigerants, please refer to Coolselector®2. Rated and extended capacities are calculated with the Coolselector®2 calculation engine to ARI standards with the ASEREP equations based on laboratory measurements of selected valves.

Dimensions and Weight

Figure 3: Dimensions for KVP

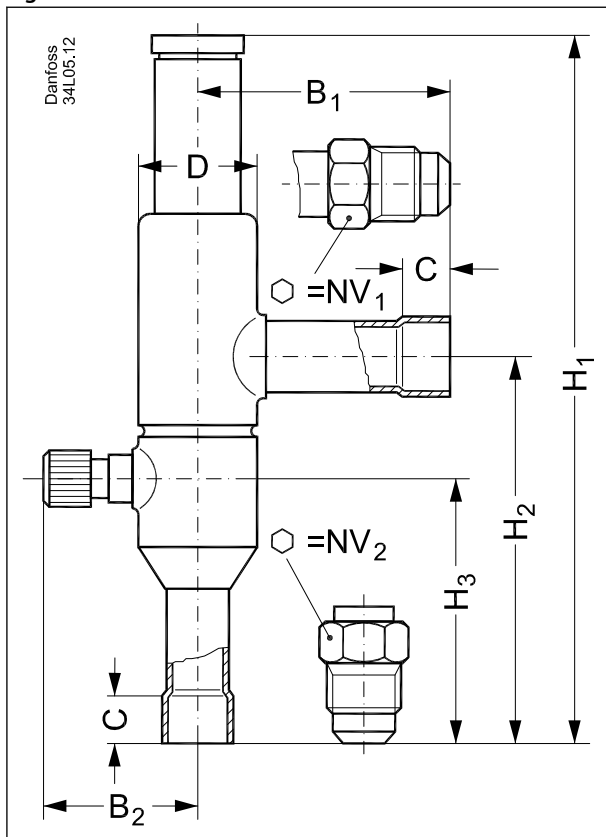
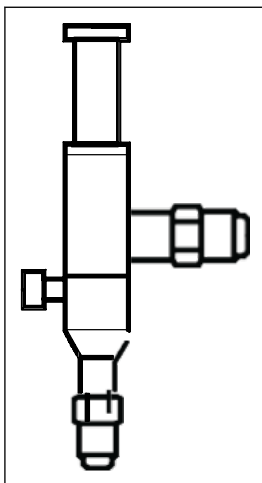
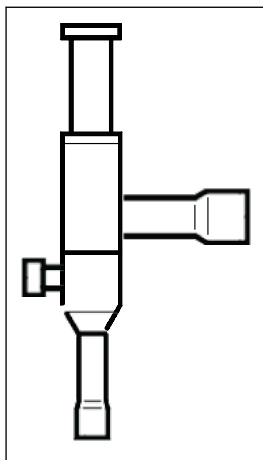

Table 10: Dimensions and Weight for KVP

Type	Connection				NV1	NV2	H1	H2	H3	B1	B2	C solder	øD	Net weight
	Flare		Solder ODF											
	[in.]	[mm]	[in.]	[mm]										
KVP 12	1/2	12	1/2	12	19	19	179	99	66	64	41	10	30	0.4
KVP 15	5/8	16	5/8	16	24	24	179	99	66	64	41	12	30	0.4
KVP 22	-	-	7/8	22	24	24	179	99	66	64	41	17	30	0.4
KVP 28	-	-	1 1/8	28	24	24	259	151	103	105	48	20	43	1
KVP 35	-	-	1 3/8	35	-	-	259	151	103	105	48	25	43	1

Ordering

Figure 4: Flare connection

Figure 5: Solder connection

Table 11: Ordering for type KVP

Type	Rated capacity ⁽¹⁾				Flare connection ⁽²⁾			Code no.	Solder connection		Code no.
	R134a	R404A/ R507	R407C	R448A	[in]	[mm]	[in]		[mm]	[in]	
KVP 12	3.1	3.8	4	4.1	1/2	12	034L0021	1/2	–	034L0023	
	3.1	3.8	4	4.1	–	–	–	–	12	034L0028	
KVP 15	3.1	3.8	4	4.1	5/8	16	034L0022	5/8	16	034L0029	
KVP 22	3.1	3.8	4	4.1	–	–	–	7/8	22	034L0025	
KVP 28	6.3	7.7	8.1	8.2	–	–	–	1 1/8	–	034L0026	
	6.3	7.7	8.1	8.2	–	–	–	–	28	034L0031	
KVP 35	6.3	7.7	8.1	8.2	–	–	–	1 3/8	35	034L0032	

⁽¹⁾ Rated capacity is the regulator capacity at

- evaporating temperature $t_e = -10\text{ °C}$
- condensing temperature $t_c = 30\text{ °C}$
- pressure drop in regulator $\Delta p = 0.2\text{ bar offset} = 0.6\text{ bar}$

To select the product for other conditions or refrigerants, use Danfoss Coolselector®

⁽²⁾ KVP supplied without flare nuts. Separate flare nuts can be supplied:

- 1/2 in / 12 mm, code no. 011L1103
- 5/8 in / 16 mm, code no. 011L1167

The connection dimensions chosen must not be too small, as gas velocities in excess of 40 m / s at the inlet of the regulator can result in flow noise.

Certificates, declarations, and approvals

The list contains all certificates, declarations, and approvals for this product type. Individual code number may have some or all of these approvals, and certain local approvals may not appear on the list.

Some approvals may change over time. You can check the most current status at danfoss.com or contact your local Danfoss representative if you have any questions.

Table 12: Certificates, declarations, and approvals

Document name	Document type	Document topic	Approval authority
UL SA7200	Mechanical - Safety Certificate	-	UL
034R9541.AA	Manufacturers Declaration	China RoHS	Danfoss
034L9630.AA	Manufacturers Declaration	ATEX	Danfoss

Online support

Danfoss offers a wide range of support along with our products, including digital product information, software, mobile apps, and expert guidance. See the possibilities below.

The Danfoss Product Store



The Danfoss Product Store is your one-stop shop for everything product related—no matter where you are in the world or what area of the cooling industry you work in. Get quick access to essential information like product specs, code numbers, technical documentation, certifications, accessories, and more.

Start browsing at store.danfoss.com.

Find technical documentation



Find the technical documentation you need to get your project up and running. Get direct access to our official collection of data sheets, certificates and declarations, manuals and guides, 3D models and drawings, case stories, brochures, and much more.

Start searching now at www.danfoss.com/en/service-and-support/documentation.

Danfoss Learning



Danfoss Learning is a free online learning platform. It features courses and materials specifically designed to help engineers, installers, service technicians, and wholesalers better understand the products, applications, industry topics, and trends that will help you do your job better.

Create your Danfoss Learning account for free at www.danfoss.com/en/service-and-support/learning.

Get local information and support



Local Danfoss websites are the main sources for help and information about our company and products. Find product availability, get the latest regional news, or connect with a nearby expert—all in your own language.

Find your local Danfoss website here: www.danfoss.com/en/choose-region.

Coolselector®2 - find the best components for you HVAC/R system



Coolselector®2 makes it easy for engineers, consultants, and designers to find and order the best components for refrigeration and air conditioning systems. Run calculations based on your operating conditions and then choose the best setup for your system design.

Download Coolselector®2 for free at coolselector.danfoss.com.

Any information, including, but not limited to information on selection of product, its application or use, product design, weight, dimensions, capacity or any other technical data in product manuals, catalogues descriptions, advertisements, etc. and whether made available in writing, orally, electronically, online or via download, shall be considered informative, and is only binding if and to the extent, explicit reference is made in a quotation or order confirmation. Danfoss cannot accept any responsibility for possible errors in catalogues, brochures, videos and other material. Danfoss reserves the right to alter its products without notice. This also applies to products ordered but not delivered provided that such alterations can be made without changes to form, fit or function of the product. All trademarks in this material are property of Danfoss A/S or Danfoss group companies. Danfoss and the Danfoss logo are trademarks of Danfoss A/S. All rights reserved.