

## Data Sheet

Hot gas powered on/off valve  
Type **ICSX**

For HFC/HCFC hot gas defrost application



ICSX hot gas powered on/off valve belongs to the ICV (Industrial Control Valve) family but it is dedicated designed for HFC/HCFC systems.

ICSX hot gas powered on/off valve is to be used in wet and dry suction lines and in liquid lines without phase change (i.e. where no expansion takes place in the valve) providing ON/OFF function in large refrigeration systems.

The valve comprises four components: valve body, function module, top cover and external pilot connection. However, only function module is with dedicated design, valve body, top cover (with one pilot pressure connection) and external pilot connection are exactly the same as standard pilot operated servo valve ICS.

One NC (normally closed) and one NO (normally open) solenoid valves with one power supply signal are needed to control the ICSX hot gas powered on/off valve. For safety purpose, it is strongly recommended to install an additional NC solenoid valve in parallel.

## Features

- Applicable to HCFC, HFC
- Modular Concept
- Fast and easy valve overhaul service
- Low pressure drop
- Designed to ensure less hot gas leakage
- Max. working pressure: 52 bar(754 psig)
- Temperature range: -60 °C to +120 °C (-76 °F to + 248 °F)
- Exact capacity and setting of the valve can be calculated for all refrigerants by means of Coolselector<sup>®</sup>2 (Select "ICS external" from the "Product families")
- Low temperature steel body
- Low weight and compact design
- Covering sizes 32 to 80, others out of this range are upon request
- Replaceable teflon valve seat
- Manual opening
- The top cover can be rotated into any possible position without affecting the operation of the valve

**Functions**

Figure 1: ICSX hot gas powered on/off valve

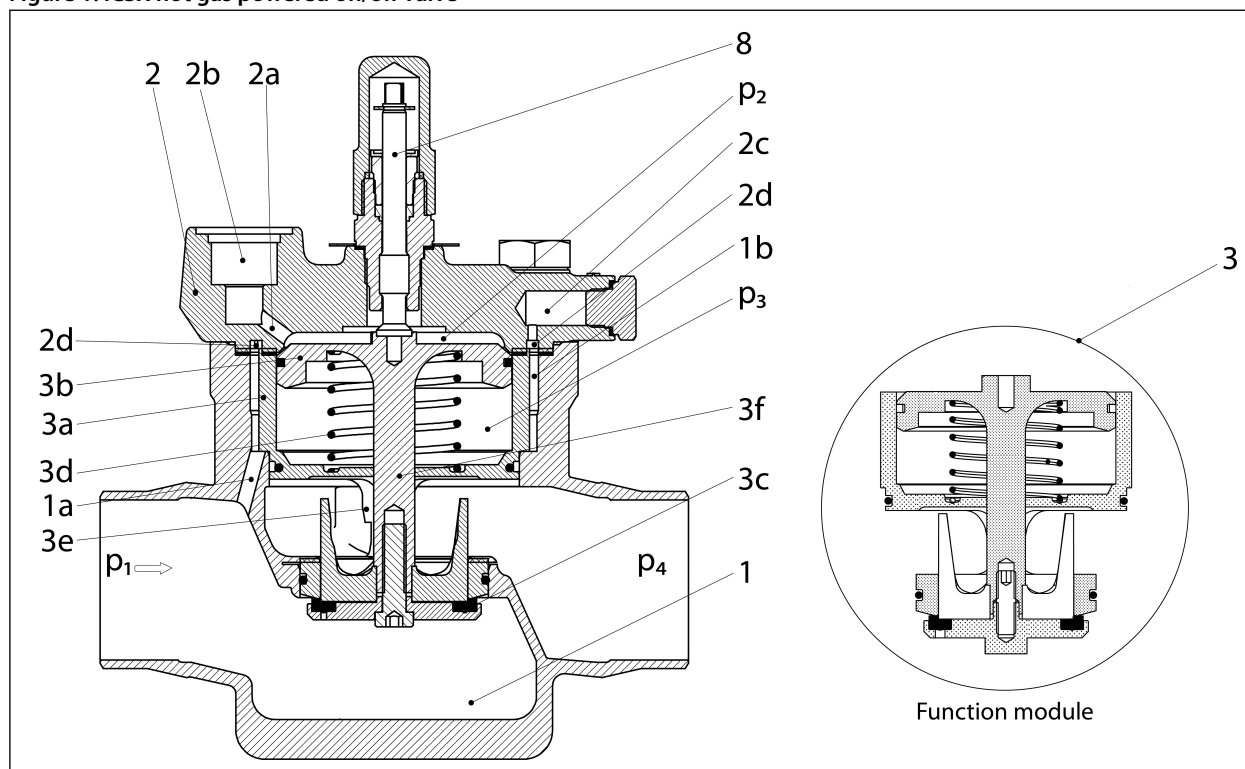

1	Body	3b	Piston
1a	Pilot channel to inlet side	3c	Valve plate
1b	Circular gap between house and module	3d	Spring
2	Top cover	3e	Cone
2a	Piston top inlet channel	3f	Piston rod
2b	External pilot connection hole	p <sub>1</sub>	Inlet pressure
2c	Pressure gauge connection	p <sub>2</sub>	Pressure on piston
2d	Circular groove	p <sub>3</sub>	Pressure underneath piston
3	Function module	p <sub>4</sub>	Outlet pressure
3a	Cylinder	8	Manual operating spindle

## Hot gas powered on/off valve, type ICSX

Figure 2: ICSX hot gas powered on/off valve

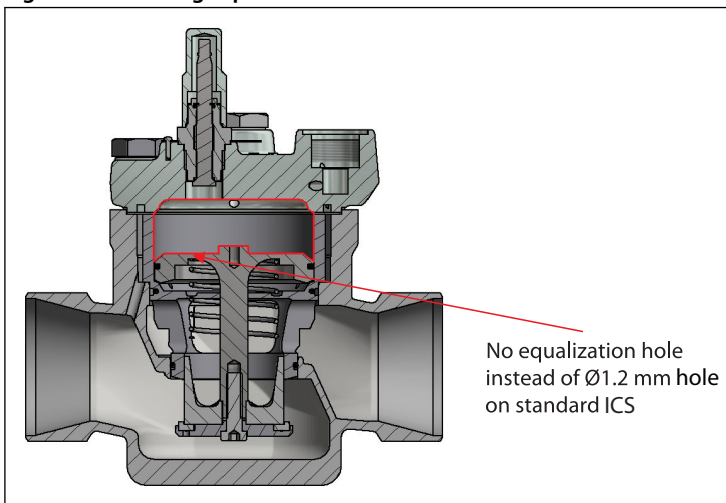

The function module of ICSX hot gas powered on/off valve is with a minor design change on current function module of ICS pilot operated servo valve. The equalization hole in the piston is removed, see [Figure 2](#). However, the top cover and housing are remain the same as current ICS pilot operated serve valve.

**NOTE:**

There is a risk of trapped cold liquid in the volume above the piston (marked red on [Figure 2](#)) and the external pilot connection and system pipes.

Figure 3: ICSX open

Solenoid NC external gas power energized, open  
Solenoid NO drain energized, closed

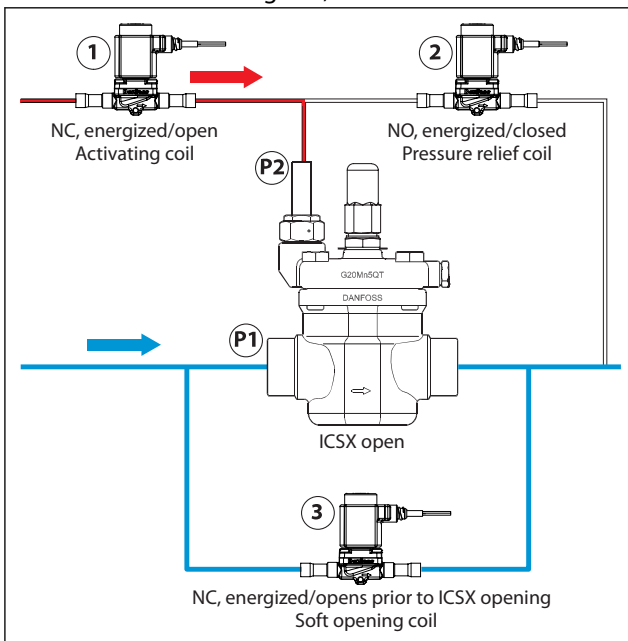
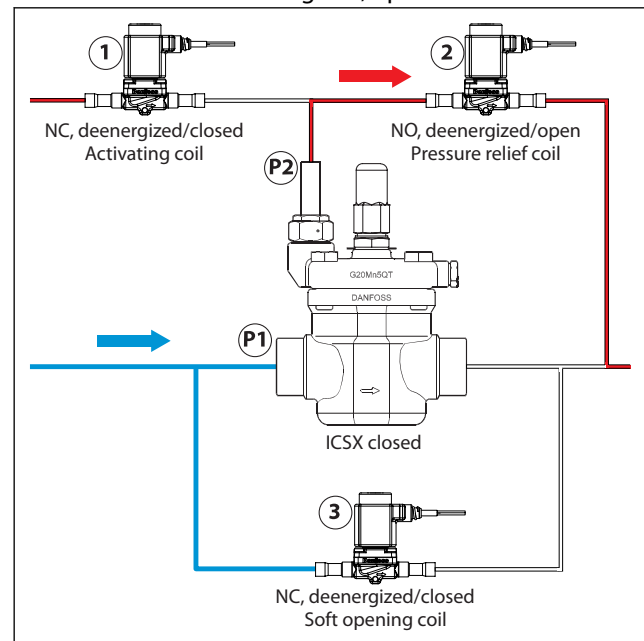

Figure 4: ICSX closed

Solenoid NC external gas power deenergized, closed  
Solenoid NO drain deenergized, open



ICSX is a pilot controlled valve used as a open/close valve in suction lines to open with external pressure. This means that the valve can operate with no internal pressure differential ( $P_d$ ) at all and provide a low pressure loss over the valve.

Low  $P_d$  is the key objective and makes the ICSX ideal for applications that are sensitive to differential pressure loss. Though  $P_d$  is kept low, it can still be quantified, and must be considered when choosing valve size. Check in the Coolselector, select "ICS external" from the "Product Families".

To assure a proper opening of the valve, the hot gas inlet pressure must be higher than 0,5 bar above the inlet pressure of the ICSX.

## Hot gas powered on/off valve, type ICSX

---

See [Figure 3](#) and See [Figure 4](#) above, two additional solenoid valves are needed to control the ICSX, pos.1(NC) and pos.2(NO) with one power supply signal. The external pilot pressure line must be connected to a system pressure (p2), and usage of NC and NO solenoid valves ensures that trapped liquid (condensed refrigerant) cannot build up excessive hydraulic pressure due to pressure relief through the NO solenoid valve. Please consider the MOPD of the solenoid valves.

ICSX hot gas powered on/off valve is kept open when power is applied to the coils of solenoid valves pos. 1 and pos. 2. It is closing and kept closed when the coils of solenoid valves pos. 1 and pos. 2 are de-energized.

It is strongly recommended to install an additional NC solenoid valve pos.3 in parallel for safety purpose so that soft opening and also high pressure after defrosting is decreased softly. The open period for solenoid valve pos.3 to drain the high pressure from evaporator has to be determined by commissioning. The opening of ICSX main valve might not be done before high pressure of evaporator be drained.

The manual spindle can be used to open the valve. Be aware of, that it might not be 100% opening. Depending on valve size.

**NOTE:**

The use of stop valves in the pilot lines need to be assessed by a risk assessment according trapped cold liquid. This risk assessment must be carried out by the designer of the plant.

If other automatic controls are used for controlling the hot gas power or other systems to control the hot gas power, a risk assessment according trapped liquid as mentioned above must be carried out by the designer of the plant.

Due to the design of the standard valve as a servo operating main valve controlled by differential pressure, the emptying of the volume over the piston (Marked red on [Figure 2](#)) might take longer than e.g. an ICLX valve. It might take several minutes when the volume is filled with condensed refrigerant. This must be considered when designing the defrost sequence, especially in the delay time for opening the hot gas line.

**Application**

Typical applications for large refrigeration systems with HFC/HCFC refrigerant, both pump and DX hot gas defrost application.

Figure 5: ICSX Functional diagram

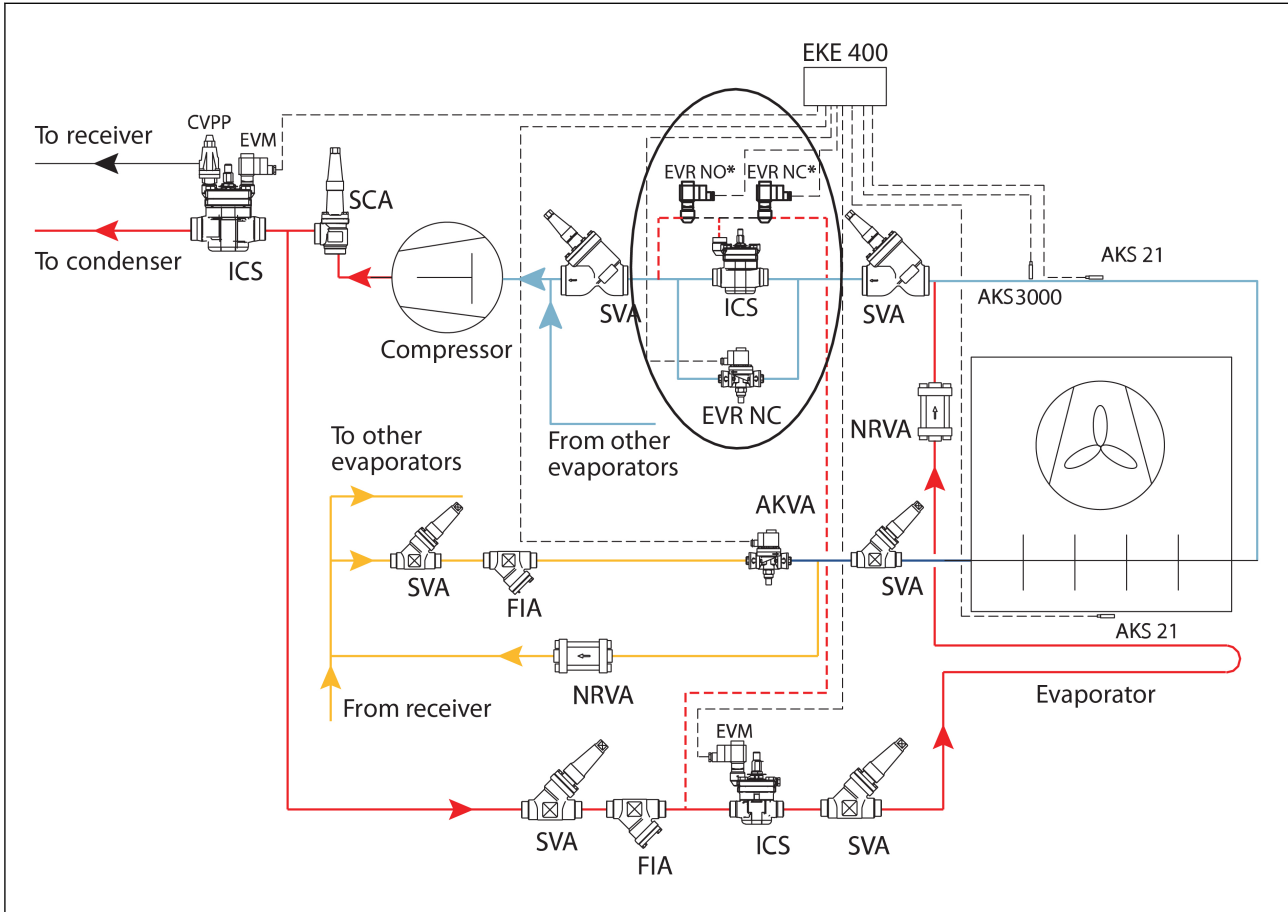

**NOTE:**

\*Choose ICS+EVRST in EKE 400 and the NC and NO solenoid valves should be connected together.

**Product specification**

**Design**

ICSX hot gas powered on/off valve uses the same top cover with 1 pilot and housing as the standard ICS, but with dedicated function modules.

ICSX hot gas powered on/off valve is no longer a standard pilot driven main valve, the one pilot hole has to be connected to the system pipe by external pilot connection, see [Ordering from the parts program](#).

Valve body and top cover material is in low temperature steel.

The external surface is zinc-chromated.

For the storage, transport and installation, the external surface of the valve housing must be protected against corrosion with a suitable top coating after installation involving welding and consequent assembly.

Protection of the ID plate when painting the valve is recommended.

**Refrigerant**

Applicable to HCFC, HFC refrigerants.

Use with flammable hydrocarbons cannot be recommended; please contact Danfoss.

**Pressure and temperature range**

**Temperature range**

-60 °C /+120 °C (-76 °F /+248 °F)

**Pressure range**

The valve is designed for: Max. working pressure: 52 bar (754 psig)

Table 1: Valve body (ICSX 80 is with 65 body but with size 80 connections)

ICV 32	ICV 40	ICV 50	ICV 65

Figure 6: Top cover 1 pilot

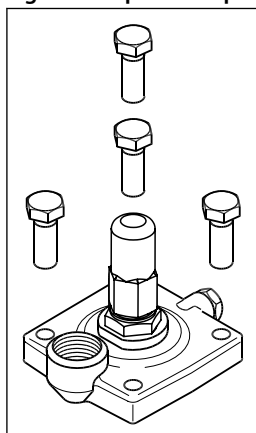

## Hot gas powered on/off valve, type ICSX

**NOTE:**

A general overview of the modular concept of ICS and various types of housings/connections can be found in the literature *“Pilot-operated servo valve, type ICS”*.

Select 1 pilot top cover only.

**Figure 7: Function modules**

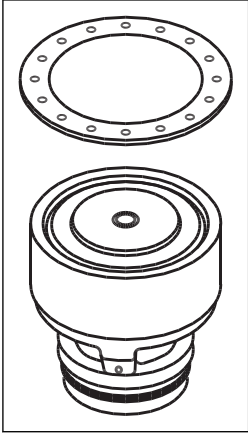

**Table 2:  $K_v$  and  $C_v$**

Type	Valve body size	$K_v$ ( $m^3/h$ )	$C_v$ (US <sub>gal/min</sub> )
ICSX 32	32	17	20
ICSX 40	40	27	31
ICSX 50	50	44	51
ICSX 65	65	70	81
ICSX 80	80	85	98



## Material specification

Figure 8: ICSX 32,40,50,65,80

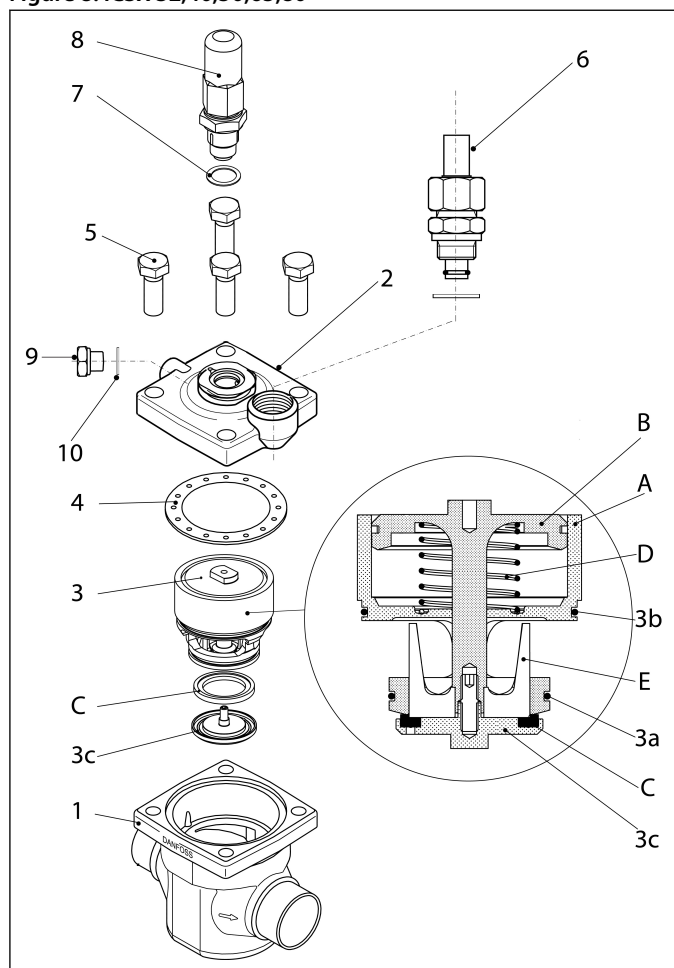

Table 3: Type and size of bolt (pos. 5)

Type	Screw
ICS 32	M14 × 35 A2-70 DIN 933
ICS 40	M14 × 40 A2-70 DIN 933
ICS 50	M16 × 40 A2-70 DIN 933
ICS 65/ICS 80	M16 × 50 A2-70 DIN 933

Table 4: Material and parts list

No.	Part	Material	EN	ASTM	JIS
1	Body	Low temperature steel	G20Mn5QT, EN 10213-3	LCC A352	SCPL1 G5151
2	Top cover	Low temperature steel	G20Mn5QT, EN 10213-3 P285QH+QT 10222-4	LCC A352 LF2, A350	SCPL1 G5151
3	Function module (assembled)				
3a	o-ring	Cloroprene (Neoprene)			
3b	o-ring	Cloroprene (Neoprene)			
3c	Washer plate	Steel			
A	Cylinder	Steel			
B	Piston	Steel			
C	Valve plate	PTFE			
D	Spring	Steel			
E	Cone	Steel			
4	Gasket	Fiber, non-asbestos			
5	Bolts	Stainless steel	A2-70, EN 1515-1	Grade B8 A320	A2-70, B 1054
6	External pilot connection	Steel			
7	Gasket	Aluminium			

## Hot gas powered on/off valve, type ICSX

No.	Part	Material	EN	ASTM	JIS
8	Manual operating spindle	Steel			
9	Plug	Steel			
10	Gasket	Aluminium			

### Valve selection based on capacity calculation

As for extended capacity calculations and valve selection based on capacities and refrigerants, please refer to Coolselector®2. Rated and extended capacities are calculated with the Coolselector®2 calculation engine to ARI standards with the ASEREP equations based on laboratory measurements of selected valves.

Download Coolselector®2 for free at [coolselector.danfoss.com](http://coolselector.danfoss.com)

### Dimensions and weights

#### ICSX 32

Figure 9: ICSX 32, Dimensions and weights

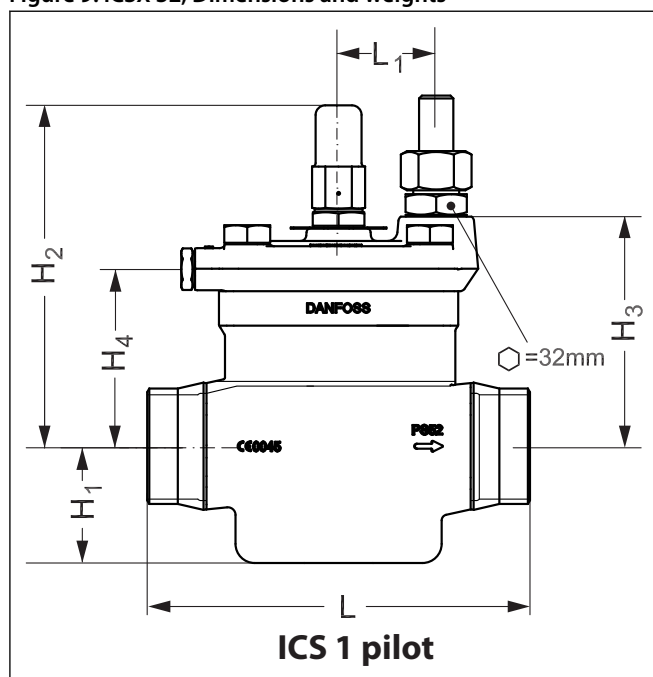

Table 5: Connection types, dimensions and weights

Connection		H <sub>1</sub>	H <sub>2</sub>	H <sub>3</sub>	H <sub>4</sub>	L	L <sub>1</sub>	Weight ICS 1 Pilot
32 D (1¼ in.)	mm	40	160	100	74	145	51	4.5 kg
	in.	1.57	6.30	3.93	2.91	5.71	2.00	9.9 lb.
40 D (1½ in.)	mm	40	160	100	74	145	51	4.5 kg
	in.	1.57	6.30	3.93	2.91	5.71	2.00	9.9 lb.
32 A (1¼ in.)	mm	40	160	100	74	145	51	4.5 kg
	in.	1.57	6.30	3.93	2.91	5.71	2.00	9.9 lb.
40 A (1½ in.)	mm	40	160	100	74	145	51	4.5 kg
	in.	1.57	6.30	3.93	2.91	5.71	2.00	9.9 lb.

#### NOTE:

Specified weights are approximate values only.

Be aware of the needed free space for external pilot connection. To be determined by designer with chosen NC/NO solenoid valves.

**D** = Butt-weld DIN

**A** = Butt-weld ANSI

ICSX 40

Figure 10: ICSX 40, Dimensions and weights

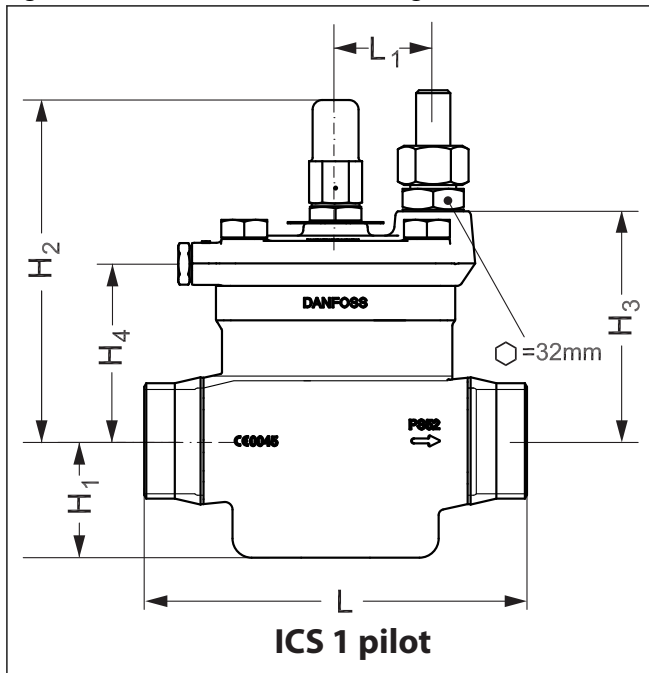

Table 6: Connection types, dimensions and weights

Connection		H <sub>1</sub>	H <sub>2</sub>	H <sub>3</sub>	H <sub>4</sub>	L	L <sub>1</sub>	Weight ICS 1 Pilot
40 D (1½ in.)	mm	49	166	105	78	160	51	5.9 kg
	in.	1.93	6.54	4.13	3.07	6.30	2.00	13.0 lb.
50 D (2 in.)	mm	49	166	105	78	180	51	5.9 kg
	in.	1.93	6.54	4.13	3.07	7.09	2.00	13.0 lb.
40 A (1½ in.)	mm	49	166	105	78	160	51	5.9 kg
	in.	1.93	6.54	4.13	3.07	6.30	2.00	13.0 lb.
50 A (2 in.)	mm	49	166	105	78	180	51	5.9 kg
	in.	1.93	6.54	4.13	3.07	7.09	2.00	13.0 lb.

**NOTE:**

Specified weights are approximate values only.

Be aware of the needed free space for external pilot connection. To be determined by designer with chosen NC/NO solenoid valves.

**D** = Butt-weld DIN

**A** = Butt-weld ANSI

ICSX 50

Figure 11: ICSX 50, Dimensions and weights

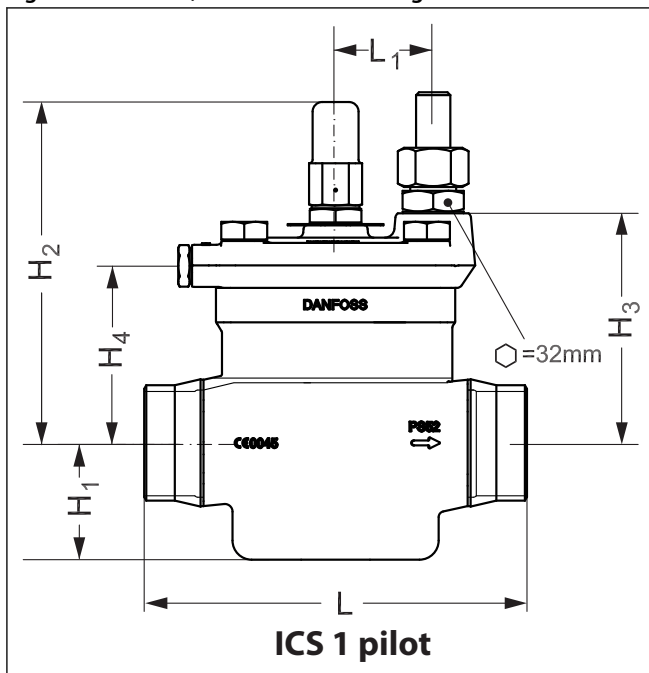

Table 7: Connection types, dimensions and weights

Connection		H <sub>1</sub>	H <sub>2</sub>	H <sub>3</sub>	H <sub>4</sub>	L	L <sub>1</sub>	Weight ICS 1 Pilot
50 D (2 in.)	mm	59	181	120	93	200	51	8.9 kg
	in.	2.32	7.13	4.72	3.66	7.87	2.00	19.6 lb.
65 D (2½ in.)	mm	59	181	120	93	210	51	8.9 kg
	in.	2.32	7.13	4.72	3.66	8.27	2.00	19.6 lb.
50 A (2 in.)	mm	59	181	120	93	200	51	8.9 kg
	in.	2.32	7.13	4.72	3.66	7.87	2.00	19.6 lb.
65 A (2½ in.)	mm	59	181	120	93	210	51	8.9 kg
	in.	2.32	7.13	4.72	3.66	8.27	2.00	19.6 lb.

**NOTE:**

Specified weights are approximate values only.

Be aware of the needed free space for external pilot connection. To be determined by designer with chosen NC/NO solenoid valves.

**D** = Butt-weld DIN

**A** = Butt-weld ANSI

ICSX 65 / ICSX 80

Figure 12: ICSX 65 / ICSX 80, Dimensions and weights

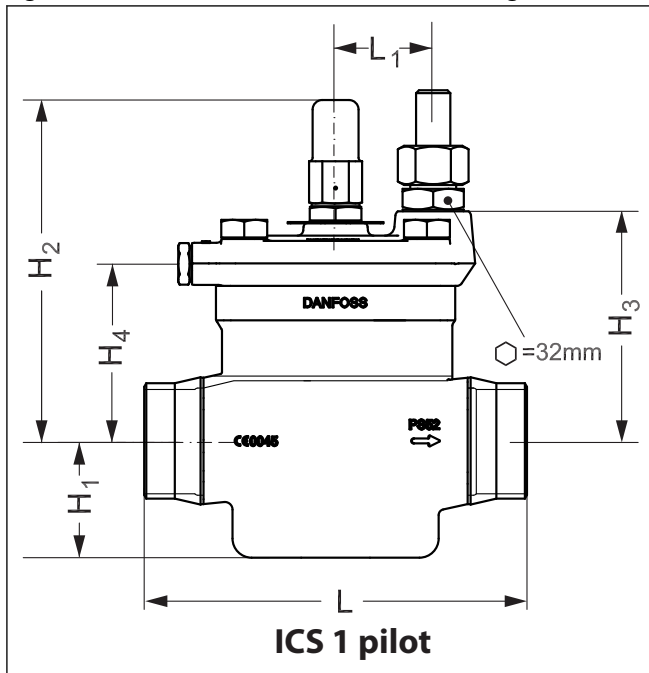

Table 8: Connection types, dimensions and weights

Connection		H <sub>1</sub>	H <sub>2</sub>	H <sub>3</sub>	H <sub>4</sub>	L	L <sub>1</sub>	Weight ICS 1 Pilot
65 D (2½ in.)	mm	65	202	140	115	230	51	13.4 kg
	in.	2.56	7.95	5.51	4.53	9.06	2.00	29.48 lb.
80 D (3 in.)	mm	65	202	140	115	245	51	13.4 kg
	in.	2.56	7.95	5.51	4.53	9.65	2.00	29.48 lb.
65 A (2½ in.)	mm	65	202	140	115	230	51	13.4 kg
	in.	2.56	7.95	5.51	4.53	9.06	2.00	29.48 lb.
80 A (3 in.)	mm	65	202	140	115	245	51	13.4 kg
	in.	2.56	7.95	5.51	4.53	9.65	2.00	29.48 lb.

**NOTE:**

Specified weights are approximate values only.

Be aware of the needed free space for external pilot connection. To be determined by designer with chosen NC/NO solenoid valves.

**D** = Butt-weld DIN

**A** = Butt-weld ANSI

**Ordering**

**Ordering from the parts program**

Figure 13: Example (select valve body, function module, top cover from ICSX 50 and external pilot connection)

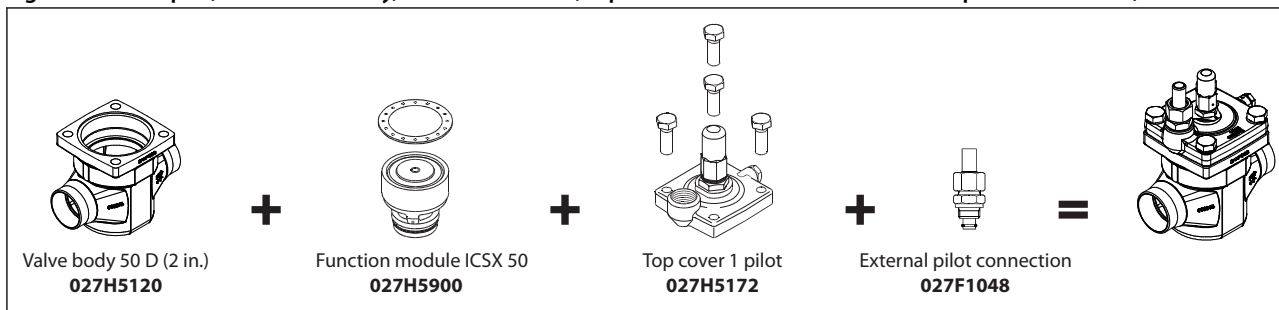

Figure 14: ICV 32,40,50,65 valve body with different connections

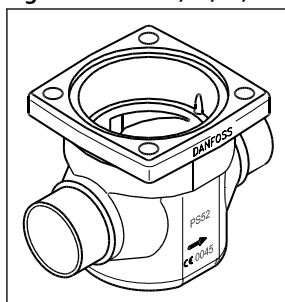

Table 9: Valve body with different connections

Valve body size	Connections	Code Number
ICV 32	32 D (1¼ in.)	027H3120
ICV 32	40 D (1½ in.)	027H3125
ICV 32	32 A (1¼ in.)	027H3121
ICV 32	40 A (1½ in.)	027H3126
ICV 40	40 D (1½ in.)	027H4120
ICV 40	50 D (2 in.)	027H4126
ICV 40	40 A (1½ in.)	027H4121
ICV 40	50 A (2 in.)	027H4127
ICV 50	50 D (2 in.)	027H5120
ICV 50	65 D (2½ in.)	027H5124
ICV 50	50 A (2 in.)	027H5121
ICV 50	65 A (2½ in.)	027H5125
ICV 65	65 D (2½ in.)	027H6120
ICV 65	65 A (2½ in.)	027H6121
ICV 65	80 D (3 in.)	027H6126
ICV 65	80 A (3 in.)	027H6127

**D** = Butt-weld DIN

**A** = Butt-weld ANSI

## Hot gas powered on/off valve, type ICSX

Figure 15: ICSX 32,40,50,65,80 function module

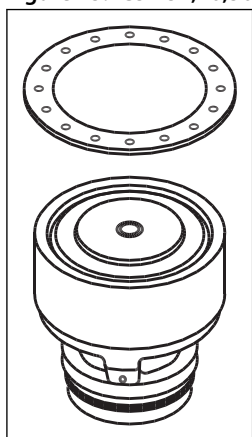

Table 10: ICSX 32,40,50,65,80 function module

Description	Code Number
ICSX 32 function module	027H3900 <sup>(1)</sup>
ICSX 40 function module	027H4900 <sup>(1)</sup>
ICSX 50 function module	027H5900 <sup>(1)</sup>
ICSX 65 function module	027H6900 <sup>(1)</sup>
ICSX 80 function module	027H8900 <sup>(1)</sup>

<sup>(1)</sup> Including gasket and o-rings

Figure 16: Top cover 1 pilot

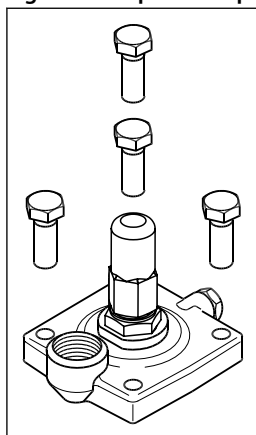

Table 11: ICS 32,40,50,65,80 top cover 1 pilot

Description	Code Number
ICS 32 top cover 1 pilot	027H3172 <sup>(2)</sup>
ICS 40 top cover 1 pilot	027H4172 <sup>(2)</sup>
ICS 50 top cover 1 pilot	027H5172 <sup>(2)</sup>
ICS 65 top cover 1 pilot	027H6172 <sup>(2)</sup>
ICS 80 top cover 1 pilot	027H8172 <sup>(2)</sup>

<sup>(2)</sup> Including bolts

**NOTE:**

The capacity of the ICSX 80 module can only be achieved when using the valve body with 80 D or A (3 in.) connections. If any other ICV 65 valve body is used the capacity of the complete valve will be reduced by approximately 6%.

## Hot gas powered on/off valve, type ICSX

Figure 17: External pilot connection

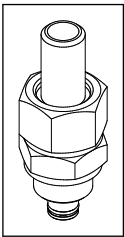

Table 12: External pilot connection

ICS	Description	Code no.
32-80	External pilot connection (incl. damping orifice, D: 1.0 mm)	027F1048

Figure 18: Dimensions of external pilot connection

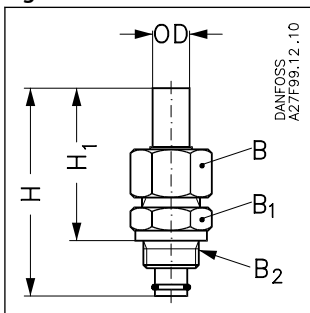
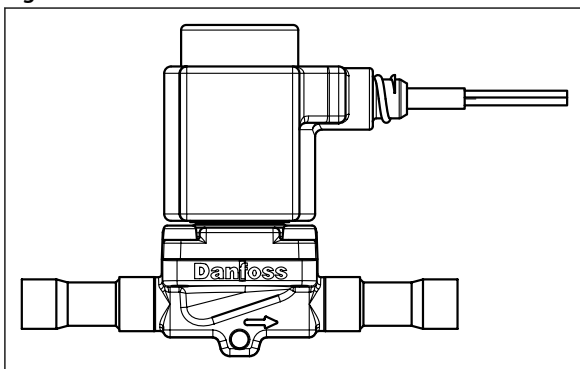

Table 13: Dimensions

Accessories		H	H <sub>1</sub>	OD	B	B <sub>1</sub>	B <sub>2</sub>
	mm	90	66	18	AF 32	AF 32	M 24 × 1.5
	in.	3.54	2.60	0.71			

## Ordering solenoid valves from Danfoss product portfolio

Figure 19: Solenoid valves



Refer [EVR Solenoid valve Data sheet](#).

For Spare parts, Please refer the Data sheet [Spare parts and accessories](#).



## Certificates, declarations and approvals

The list contains all certificates, declarations, and approvals for this product type. Individual code number may have some or all of these approvals, and certain local approvals may not appear on the list.

Some approvals may change over time. You can check the most current status at danfoss.com or contact your local Danfoss representative if you have any questions.

### Valid approvals

Table 14: The ICV valve approvals

	<p>The ICV valve concept is designed to fulfill global refrigeration requirements. For specific approval information, please contact Danfoss.</p> <p>The ICSX valves are approved in accordance with the European standard specified in the Pressure Equipment Directive and are CE marked.</p>
---	---

Table 15: ICSX valves

ICSX valves		
Nominal bore	DN 32-65 (1¼ - 2½ in.)	DN 80 (3 in.)
Classified for	Fluid group I	
Category	II	III

Table 16: Certificates and declarations

File name	Document type	Document topic	Approval authority
RU Д-ДК.БЛ08.В.00191_18	EAC Declaration	Machinery & Equipment	EAC
0045 202 1204 Z 00354 19 D 001(00)	Pressure - Safety Certificate	-	TÜV
RU Д-ДК.БЛ08.В.00189_18	EAC Declaration	EMC	EAC
RU Д-ДК.РА01.В.72054_20	EAC Declaration	PED	EAC
RU С-ДК.БЛ08.В.01093_20	Pressure - Safety Certificate	PED	EAC
033F0685.AK	EU Declaration	EMCD/PED	Danfoss
033F0691.AE	Manufacturers Declaration	RoHS	Danfoss
0045 202 1204 Z 00355 19 D 001(00)	Pressure - Safety Certificate	-	TÜV
19.10325.266	Marine - Safety Certificate	-	RMRS

## Online support

Danfoss offers a wide range of support along with our products, including digital product information, software, mobile apps, and expert guidance. See the possibilities below.

### The Danfoss Product Store



The Danfoss Product Store is your one-stop shop for everything product related—no matter where you are in the world or what area of the cooling industry you work in. Get quick access to essential information like product specs, code numbers, technical documentation, certifications, accessories, and more.

Start browsing at [store.danfoss.com](https://store.danfoss.com).

### Find technical documentation



Find the technical documentation you need to get your project up and running. Get direct access to our official collection of data sheets, certificates and declarations, manuals and guides, 3D models and drawings, case stories, brochures, and much more.

Start searching now at [www.danfoss.com/en/service-and-support/documentation](https://www.danfoss.com/en/service-and-support/documentation).

### Danfoss Learning



Danfoss Learning is a free online learning platform. It features courses and materials specifically designed to help engineers, installers, service technicians, and wholesalers better understand the products, applications, industry topics, and trends that will help you do your job better.

Create your Danfoss Learning account for free at [www.danfoss.com/en/service-and-support/learning](https://www.danfoss.com/en/service-and-support/learning).

### Get local information and support



Local Danfoss websites are the main sources for help and information about our company and products. Find product availability, get the latest regional news, or connect with a nearby expert—all in your own language.

Find your local Danfoss website here: [www.danfoss.com/en/choose-region](https://www.danfoss.com/en/choose-region).

### Spare Parts



Get access to the Danfoss spare parts and service kit catalog right from your smartphone. The app contains a wide range of components for air conditioning and refrigeration applications, such as valves, strainers, pressure switches, and sensors.

Download the Spare Parts app for free at [www.danfoss.com/en/service-and-support/downloads](https://www.danfoss.com/en/service-and-support/downloads).

### Coolselector®2 - find the best components for you HVAC/R system



Coolselector®2 makes it easy for engineers, consultants, and designers to find and order the best components for refrigeration and air conditioning systems. Run calculations based on your operating conditions and then choose the best setup for your system design.

Download Coolselector®2 for free at [coolselector.danfoss.com](https://coolselector.danfoss.com).

Any information, including, but not limited to information on selection of product, its application or use, product design, weight, dimensions, capacity or any other technical data in product manuals, catalogues descriptions, advertisements, etc. and whether made available in writing, orally, electronically, online or via download, shall be considered informative, and is only binding if and to the extent, explicit reference is made in a quotation or order confirmation. Danfoss cannot accept any responsibility for possible errors in catalogues, brochures, videos and other material. Danfoss reserves the right to alter its products without notice. This also applies to products ordered but not delivered provided that such alterations can be made without changes to form, fit or function of the product. All trademarks in this material are property of Danfoss A/S or Danfoss group companies. Danfoss and the Danfoss logo are trademarks of Danfoss A/S. All rights reserved.