

Installation guide

ELIMINATOR® Hermetic filter drier

Type DML / DCL

023R9514

023R9514

Refrigerants: R134a, R404A, R407C, R507, R22, R410A and other refrigerants (HCFC, HFC, HFO, HC)	Temperature range: -40 - 70 °C -40 - 160 °F
--	--

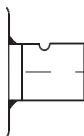
Solder pure copper 	1.5, 03, 05, 08, 16, 30, 60 cu in.	$\frac{1}{4} - \frac{7}{8}$ in. ODM / ODF	PS/MWP 46 bar/667 psig
		$\frac{1}{8}$ in. ODM / ODF	
	38, 41 cu in.	$\frac{3}{4} - \frac{7}{8}$ in. ODM / ODF	PS/MWP 35 bar/500 psig
		$1\frac{1}{8}$ in. ODM / ODF	
75 cu in.	$\frac{3}{4} - 1\frac{1}{8}$ in. ODM / ODF		

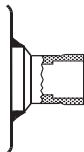
Solder cu-plated 	03 – 60 cu in.	$\frac{1}{4} - \frac{7}{8}$ in. ODF	PS/MWP 46 bar/667 psig
		$1\frac{1}{8}$ in. ODF	
	75 cu in.	$\frac{7}{8} - 1\frac{1}{8}$ in. ODF	

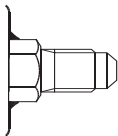
Flare and face seal 	03 – 75 cu in.	$\frac{1}{4} - \frac{3}{4}$ in.	PS/MWP 46 bar/667 psig
--	----------------	---------------------------------	---------------------------

Soldering

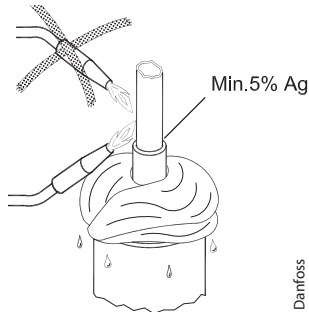

Danfoss
23Z7016.10

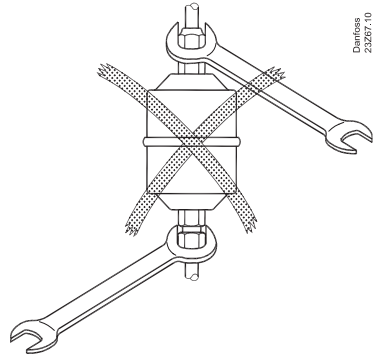
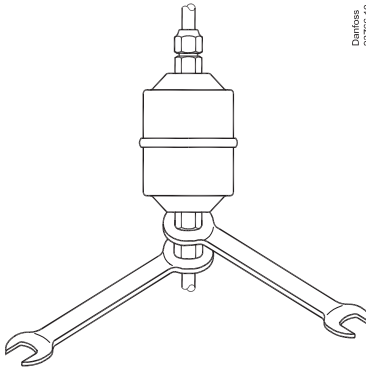

After charging, mark the system with the refrigerant and the oil used.

Mounting

