

Indoor unit
SPHERA EVO 2.0 - Tower
SQKN-YEE 1 TC 2.1-8.1

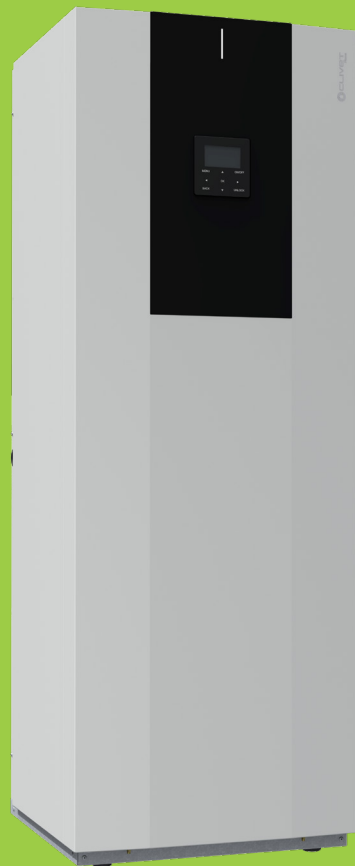

Installation
and maintenance
manual

en



ROMANIAN



BULGARIAN



SLOVENIAN



HRVATSKI



MOGL00002-07 INST
05-2024

Dear Customer,

We congratulate you on choosing these product.

Clivet has been working for years to offer systems able to assure the maximum comfort for a long time with highly-reliable, efficient, high-quality and safe solutions.

The target of the company is to offer advanced systems, that assure the best comfort and reduce energy consumption as well as the installation and maintenance costs for the entire life-cycle of the system.

With this manual, we want to give you information that are useful for all phases: from reception, installation and use to disposal - so that such an advanced system can provide the best performances during installation and use.

Best regards and have a good read.

CLIVET Spa

The original instructions are written in Italian.

All other languages are translations of the original instructions.

The data contained in this manual is not binding and may be changed by the manufacturer without prior notice. Reproduction, even partial, is FORBIDDEN.

© Copyright - CLIVET S.p.A. - Feltre (BL) - Italia.

Summary

1.	Glossary	6
2.	General	7
2.1	About the manual.....	7
2.2	General safety warnings.....	8
3.	About R-32 refrigerant	9
3.1	Warnings for the installer and the Technical Support Service.....	10
3.2	General warnings	10
3.3	Safety checks and procedures	10
3.4	Installation requirements.....	13
4.	Presentation of the product	17
4.1	Identification	17
4.2	Regulatory framework	17
4.3	Intended use	17
4.4	Description	17
4.5	Combinations.....	17
4.6	Main components.....	18
4.7	Components supplied with the unit.....	19
4.8	Compatible accessories	19
5.	Before installation	20
5.1	Prerequisites	20
5.2	Reception.....	20
5.3	Storage.....	20
5.4	Handling	21
5.5	Removal of the packaging	21
6.	Installation	23
6.1	Prerequisites	23
6.2	General diagram	23
6.3	Clearances	24
6.4	Access to internal parts.....	24
7.	Water connections	26
7.1	General system diagram example.....	26
7.2	Prerequisites	27
7.3	Water flow-rate	27
7.4	Minimum water content	27
7.5	Water characteristics.....	27
7.6	Cleaning	27
7.7	Piping insulation	28
7.8	Hydraulic circuit antifreeze protection.....	28
7.9	Position of connections.....	28
7.10	Hydraulic connection	29
7.11	Water filter.....	29
7.12	System filter.....	29
7.13	DHW safety valve	30

7.14	Relief valves	30
7.15	DHW tank filling	30
7.16	Loading the plant.....	31
8.	Refrigerant connections	33
8.1	Prerequisites	33
9.	Electrical connections	35
9.1	Prerequisites	35
9.2	General diagram	36
9.3	Cable inlet.....	37
9.4	Connecting the power supply	37
9.5	External component connections.....	39
9.6	Zone thermostat	44
9.7	SMART GRID - Photovoltaic management.....	45
9.8	Control4 NGR	46
10.	Starting up the system.....	47
10.2	SYSTEM CONFIGURATION	49
11.	Start-up	50
11.1	Compressor casing heater	50
11.2	Opening the "For serviceman" menu	50
11.3	Air vent.....	50
11.4	Test of operating modes.....	50
11.5	Start-up report	51
11.6	2014/68/UE PED directive	51
12.	Maintenance	52
12.1	Prerequisites	52
12.3	Unit booklet.....	54
12.4	Standby mode	54
12.5	Emptying the system.....	54
12.6	Cleaning the outer coating.....	54
12.7	Structure	54
12.8	Water pressure.....	54
12.9	Water filter.....	54
12.10	Expansion vessel.....	54
12.11	Unit electrical panel.....	54
12.12	Using glycol	54
12.13	Magnetic sludge	55
12.14	Safety valve.....	56
12.15	Valve motor assembly	56
12.16	Anode replacement.....	57
12.17	Fan	57
12.18	Condensate drain	57
12.19	Air coil.....	57
13.	Decommissioning	59
13.1	Disconnection	59
14.	Residual risks	60
14.1	General.....	60

14.2	Danger zone.....	60
14.3	Handling	60
14.4	Installation.....	60
14.5	Refrigerant.....	61
14.6	Hydraulic parts.....	61
15.	Advanced applications	62
15.1	Units connected in cascade.....	62
16.	Technical data	66
17.	Energy labels	75

1. Glossary

Acronyms or abbreviations are used in this manual to indicate components or parameters. The acronyms and their meanings are given in the table.

Sign	Description
DHW	Domestic hot water
AHS	Backup boiler
HMI	User interface
IBH	Backup electric heater
OFN	Oxygen-Free-Nitrogen
P _i	Unit pump
P _o	Secondary circuit pump (or Zone 1 pump for double zone systems)
P _c	Zone 2 pump (for double zone systems)
P _d	DHW recirculation pump
P _s	Solar circuit pump
Pe	Evaporation pressure in Cooling or Condensation pressure in Heating
SV1	3-way circuit/DHW diverter valve
SV2	3-way diverter valve for direct double zone systems
SV3	3-way mixing valve for mixed circuit
TBH	Backup electric heater for DHW tank
T1	Water supply temperature from additional heating source (with IBH heater or AHS boiler)
T2	Refrigerant temperature entering the user side exchanger (plate heat exchanger) in Cooling mode (or leaving in Heating mode)
T3	Refrigerant temperature leaving the source exchanger (coil) in Cooling mode (or entering in Heating mode)
T4	Outdoor air temperature
T5	DHW tank temperature
T1S	Water supply temperature setpoint
Ta	Room air temperature, detected by the probe in the HMI
Tbt1	Temperature of the upper part of the inertial storage tank
Th	Compressor suction refrigerant temperature
Tp	Compressor discharge refrigerant temperature
Tsolar	Water temperature in the solar thermal circuit
Tw2	Water supply temperature for the mixed zone (for double zone systems)
TWin	Unit water return temperature
TWout	Unit water supply temperature
ODU	External unit
IDU	Internal unit

2. General

2.1 About the manual

- The manual ensures proper installation, use and maintenance of the unit
- this manual is an integral and essential part of the product
- keep this manual together with the wiring diagram in an accessible place for the operator. It should always accompany the product, even if it is transferred to another owner or user
- recipients of the instructions in the manual are indicated in the "Recipients" chapter
- the recipient is indicated at the beginning of each section of the manual
- recipients, to the extent of their responsibility, are required to read the instructions and warnings in this manual as they provide important information on safe installation, use and maintenance.

Remember that:

- the manufacturer The manufacturer accepts no liability for damage to persons or property resulting from failure to observe the rules in this manual
- failure to observe the instructions in this manual will result in forfeiture of the warranty
- the manufacturer reserves the right to make changes or improvements to this documentary material and to the units without prior notice
- visit the manufacturer's website for up-to-date details
- this manual contains proprietary information, all rights reserved, it may not be reproduced or photocopied, either in whole or in part, without the prior written consent of manufacturer.

2.1.1 Symbols

The symbols in the following chapter can be found in the manual and on the product, and provide quick and clear information for correct and safe use.

2.1.1.1 Safety symbols

Danger

This symbol indicates warnings, failure to comply may result in serious harm to health and fatal injuries.

Warning

This symbol indicates warnings, failure to comply may result in irreparable damage to the product or harm to the environment.

Prohibition

This symbol indicates operations that must never be carried out.

Note

This symbol indicates important information.

2.1.1.2 Editorial symbols

In the texts

Purpose of the action: indicates the purpose of a sequence of actions.

(it is identified by bold text followed by :)

- ▶ this symbol indicates actions that are required
- this symbol indicates the expected result after an action
- this symbol indicates the lists

In the images

1 uniquely indicates a component

 indicates a group of components

 indicates a sequence of actions

In the images, dimensions are expressed in millimetres unless otherwise indicated.

2.1.1.3 Symbols on the unit

The following symbols are used in some parts of the product:

Instructions for the User

Read the User Manual carefully before using the product.

Instructions for the User

Read the Installer Manual carefully before installing the product.

Instructions for the Technical Support Service

Read the Technical Support Service Manual carefully before carrying out any operation on the product.

2.1.2 Recipients

2.1.2.1 User

Inexperienced person who is capable of:

- operating the product safely for people, for the product and for the environment
- interpreting elementary diagnostics of faults and abnormal operating conditions
- carrying out simple adjustment, test and maintenance operations.

2.1.2.2 Installer

Experienced and qualified person able to:

- to put the product in a safe operating condition for people, for the product and for the environment
- to comply with the regulations in force in the country of destination
- to provide the user with basic information on safe use and maintenance in accordance with this manual and current national regulations
- comply with the regulations in force in the country of destination.

2.1.2.3 Technical support service





Experienced person, qualified and authorised directly by the manufacturer to:















- carry out a diagnosis of product faults and abnormal operation, possibly using information provided by the user
- rectify faults, carrying out the necessary repairs, replacements and adjustments that will restore the product's ability to function correctly and safely for the people, for the product and for the environment
- comply with the regulations in force in the country of destination.

2.1.3 Document organisation

- The manual is divided into sections, each dedicated to one or more recipients
- the recipient is indicated at the beginning of each section of the manual.

2.2 General safety warnings

-  Read the "About the manual" chapter carefully before proceeding with any operation.
-  Each chapter contains specific warnings for the operations given therein. These warnings should be read before starting any activities.
-  For every operation, always comply with current national regulations.
-  All personnel must be aware of the operations and of the hazardous situations that may arise when starting any operations on the unit.

-  Any contractual and non-contractual liability for damage caused to persons, animals or property by installation, adjustment or maintenance errors or improper use is excluded.
-  Any uses not expressly indicated in this manual are not permitted.
-  Do not change or tamper with the device as this can lead to hazardous situations.
-  Use appropriate safety clothing and equipment.
-  The manufacturer accepts no liability for failure to comply with current safety and accident prevention regulations.
-  The manufacturer reserves the right to make changes to its models at any time to improve its product, subject to the essential characteristics described in this manual.
-  The manufacturer is not obliged to add these changes to units previously manufactured, already delivered or being built.
-  The unit is suitable for use by children aged 8 years and over and by persons with reduced physical, sensory or mental capabilities or lack of experience or knowledge if they are properly supervised or have received instructions on the safe use of the device and have understood the associated hazardous situations. Children must not play with the device. Cleaning and maintenance operations must not be carried out by children without supervision.
-  It is forbidden to touch the device with wet or damp parts of the body.
-  It is forbidden to carry out any operation before disconnecting the device from the mains power supply by turning the system's main switch to "off".
-  It is forbidden to change the safety or control devices without the device manufacturer's authorisation and instructions.
-  It is forbidden to pull, unplug or twist the electrical cables coming out of the device, even if it is disconnected from the mains power supply.
-  It is forbidden to introduce objects and substances through the air intake and supply grilles.
-  It is forbidden to open the access doors to internal parts of the unit without first turning the system's main switch to "off".

3. About R-32 refrigerant

This section contains specific safety information and warnings on the use of R-32 refrigerant.

 For more comprehensive information, read the safety data sheet for the refrigerant used.

 The refrigerant used inside this unit is flammable. A refrigerant leak that is exposed to an external ignition source can create fire risks.

Quantity of refrigerant charged at the factory and tons of equivalent CO₂:







Size	Refrigerant quantity charged at the factory	
	Refrigerant / kg	Tons of equivalent CO ₂
2.1	1,50	1,02
3.1	1,50	1,02
4.1	1,65	1,11
5.1	1,65	1,11
6.1	1,84	1,24
7.1	1,84	1,24
8.1	1,84	1,24

Physical characteristics of R-32 refrigerant		
Safety class (ISO 817)	A2L	
GWP (Global Warming Potential)	675	100 yr ITH
GWP (Global Warming Potential)	677	ARS 100 yr ITH
LFL Low flammability limit	0,307	kg/m ³ @ 60 °C
BV Burning velocity	6,7	cm/s
Normal boiling point	-52	°C
Self-ignition temperature	648	°C

3.1 Warnings for the installer and the Technical Support Service

-  The use of flammable refrigerants entails specific safety warnings for certain operations during installation and maintenance.

3.2 General warnings

-  The refrigerant used inside this unit is highly flammable. A refrigerant leak that is exposed to an external ignition source can create fire risks.
-  Before starting work on systems containing flammable refrigerants, safety checks must be carried out to ensure that the risk of combustion is minimised.
-  Installation and maintenance personnel and other people working in the area should be informed about the nature of the work to be done.
-  Do not pierce or burn.
-  The unit must be protected from accidental impacts so as to prevent mechanical damage that would cause a refrigerant leak.
-  Ensure that there are no continuously operating ignition sources (naked flames, gas appliances, electric stoves, lit cigarettes, etc.).
-  Do not place flammable objects (spray cans) within 1 metre of the exhaust air.

3.3 Safety checks and procedures

Before starting an intervention, carry out appropriate safety checks to ensure that the risk of ignition is minimal. Follow these precautions before starting an intervention:

3.3.1 Checks in the area

Perform the following checks:

- carry out safety checks to ensure that the risk of combustion is minimised
- avoid working in tight spaces
- mark the area around the work space
- ensure safe working conditions around the area and check that there is no flammable material.

3.3.2 Work procedures

- Interventions must be carried out according to a controlled procedure in order to minimise the risk of flammable gases or vapours being present during the work.

3.3.3 Checking the presence of refrigerant

Perform the following checks:

- the area must be checked using an appropriate refrige-

rant detector before and during the intervention so that the technician is aware of potentially flammable atmospheres

- check that the leak detector is suitable for use with flammable refrigerants (it does not generate sparks and is adequately sealed or intrinsically safe)
- check that it is placed in a suitable space to promptly check for leaks linked to the maintenance activity carried out

-  It is forbidden to use leak detectors with halogen lamps.

-  Remember that R-32 refrigerant is heavier than air.

3.3.4 Presence of fire extinguishers

When performing hot operations on refrigeration equipment or associated components:

- keep a suitable extinguisher at hand
- keep a dry-powder or CO₂ extinguisher near the work area.

3.3.5 Absence of ignition sources

When operations to be carried out on a refrigeration system involve exposing piping containing or having contained a flammable refrigerant.

Perform the following checks:

- all possible ignition sources, including cigarette smoke, should be kept at a sufficient distance from the installation, fixing, disassembly and disposal site, as flammable refrigerant may escape into the surrounding space during these operations.
- before starting the intervention, the area around the unit must be inspected to check that it does not present ignition or flammability hazards.

-  It is forbidden to use any ignition source that could generate a risk of fire or explosion.

-  It is forbidden to smoke near the unit. "NO SMOKING" signs must be affixed.

-  It is forbidden to use a mobile phone near the unit.

3.3.6 Area ventilation

Before working on the system or performing hot operations.

Perform the following checks:

- the area must either be open or adequately ventilated
- ventilation must be constant throughout the entire operation and be capable of safely dispersing all refrigerant released and preferably expelling it outside into the atmosphere.

3.3.7 Checks on the refrigeration system

Perform the following checks:

- if an electrical component is replaced, the new one must

- be suitable for the intended use and in accordance with the correct specifications
- follow the manufacturer's maintenance and service instructions in all circumstances
- when in doubt, consult the manufacturer's technical department
- the charge volume must be suitable for the room volume and the intended use in which the components containing the refrigerant are installed, see the electrical installation requirements in EN 378
- ventilation devices and openings must open properly and not be obstructed
- if an indirect refrigerant circuit is used, the presence of refrigerant in the secondary circuits must be checked
- equipment markings must remain visible and legible
- markings and indications that become illegible must be corrected
- pipes or other components of the refrigerant circuit must be installed in locations where exposure to potentially corrosive substances is unlikely for components containing the refrigerant, unless they are made of materials inherently resistant to corrosion or adequately protected against the risk of corrosion.

3.3.8 Checks on electrical devices

Remember that:

- the fixing and maintenance procedures for electrical components must include initial safety checks and component inspection procedures
- if a defect is found that may generate safety risks, the power supply to the circuit must be interrupted until the problem is satisfactorily resolved
- if the problem cannot be solved immediately, but it is necessary to keep the system in operation, an appropriate temporary solution must be adopted
- the situation should be communicated to the owner of the unit so that all persons concerned can be duly informed.

Carry out the following checks:

- check that the capacitors are discharged: this procedure must be performed safely to avoid the possibility of sparks
- check that there are no live components or wires exposed while charging, resetting or venting the system
- check for ground fault interruptions
- check that the unit is not powered and if necessary disconnect the power supply before proceeding with the next steps.

3.3.9 Fixing sealed components

Remember that:

- all electrical users must be disconnected from the equipment before removing the seal covers, etc.

- if it is absolutely necessary to have a power supply during the intervention, a permanent leak detection method must be set up at the most critical point to signal any potentially dangerous situations
- the use of silicone sealants may make some types of leak detection equipment less effective.

Ensure that:

- the casing must not be altered to such an extent that the required level of protection is compromised, including damage to cables, excessive number of connections, use of terminals that do not conform to the original specifications, damage to seals, incorrect assembly of glands, etc.
- the device must be installed safely.
- seals or sealing materials have not deteriorated to such an extent that they no longer ensure a perfect seal keeping flammable atmospheres from entering
- spare parts must comply with the manufacturer's specifications.

3.3.10 Fixing intrinsically safe components

Remember that:

- before applying capacitance or permanent inductance loads to the circuit, check that this operation does not result in the permissible voltage and current values for the equipment in use being exceeded
- intrinsically safe components are the only types of components that can be operated under voltage in the presence of a flammable atmosphere
- the test device must have the correct nominal characteristics
- only use parts specified by the manufacturer to replace components
- other components can cause ignition of the refrigerant released into the atmosphere.



3.3.11 Wiring

Check that:

- the wiring must not be exposed to wear, corrosion, excessive pressure, vibration, sharp edges or other adverse environmental influences.

 The check should also take into account the effects of ageing or continuous vibration from compressors, fans or other similar sources.

3.3.12 Detection of flammable refrigerants

-  The use of potential ignition sources for the search or detection of refrigerant leaks is prohibited under any circumstances.
-  The use of halogen torches or other naked flame detection systems is not permitted.

3.3.13 Leak detection methods

Remember that:

- electronic leak detectors can be used to detect flammable refrigerants, but their sensitivity may not be adequate or require recalibration
- detection equipment must be calibrated in a refrigerant-free area
- the detector is not a potential ignition source and is suitable for the refrigerant
- leak detection equipment must be configured at a percentage of the lower flammability limit (LFL) of the refrigerant and be calibrated for the refrigerant used with confirmation of the appropriate gas percentage (max. 25%)
- leak detection fluids are suitable for use with most refrigerants but the use of detergents containing chlorine should be avoided, as chlorine can react with the refrigerant and corrode copper piping.

If there is a refrigerant leak:

- remove or extinguish all naked flames
- if brazing is required, all of the refrigerant must be removed from the system, or isolated (by means of shut-off valves) in a part of the system away from the leak
- purge the system with oxygen-free nitrogen (OFN) both before and during brazing.

3.3.14 Removal and evacuation

Follow the procedure below:

- ▶ remove the refrigerant
- ▶ purge the circuit with inert gas
- ▶ evacuate
- ▶ purge again with inert gas
- ▶ open the circuit by cutting or brazing

Remember that:

- the refrigerant charge can be recovered in the appropriate cylinders
- the system must be purged with oxygen-free nitrogen to make the unit safe
- it may be necessary to repeat this procedure several times
- compressed air or oxygen must not be used for this operation
- purging can be performed by introducing oxygen-free nitrogen into the vacuum circuit in the system and continuing to fill until the operating pressure is reached, then venting into the atmosphere and recreating the vacuum
- this procedure must be repeated until the refrigerant is completely exhausted from the system.

When the last charge of OFN is added:

- the system must be vented to barometric pressure to allow the work to be performed

i This operation is absolutely essential if brazing operations are to be carried out on the piping.

- check that the vacuum pump outlet is not closed for any ignition source and that good ventilation is available.

3.3.15 Charging operations

Remember that:

- when using charging equipment, avoid contamination with different refrigerants
- cylinders must be kept upright
- before the refrigerant is charged into the system, ensure that it is properly earthed
- the system must be labelled after charging (if the label is not already present)
- extreme care must be taken to avoid overfilling or underfilling the system
- before recharging the system, the pressure must be tested using oxygen-free nitrogen
- after charging, but before start-up, the system should not leak
- an additional check for leaks must be carried out before leaving the site.

3.3.16 Decommissioning

Remember that:

- before performing this procedure, it is essential that the technician is fully familiar with the equipment and all of its components
- all refrigerants must be recovered following safe procedures
- an oil and refrigerant sample must be taken before proceeding
- before reusing the recovered refrigerant, it should be analysed
- before starting the procedure, it is essential to check that the power supply is available
- electrically isolate the system.

Before proceeding, check that:

- mechanical equipment for handling refrigerant cylinders is available, if necessary
- the necessary personal protective equipment is available and is used
- the recovery process is carried out under the constant supervision of a competent person
- the recovery equipment and cylinders comply with the regulations in force.

To recover:

About R-32 refrigerant

- if possible, transfer the refrigerant to the unit using a “pump-down” procedure
- if it is not possible to create a vacuum, use a manifold that allows the refrigerant to be exhausted from various parts of the system
- place the cylinder on the scale
- start the recovery device and use it according to the manufacturer's instructions
- do not fill the cylinders excessively. (Do not exceed 80% of the liquid volume)
- do not exceed the maximum working pressure of the cylinder, even temporarily
- after filling the cylinders correctly and completing the procedure, transfer the cylinders and equipment from the site as soon as possible and close all shut-off valves on the equipment.
- before charging the recovered refrigerant into another refrigeration system, it must be cleaned and checked.

3.3.17 Labelling

Remember that:

- the device must be labelled to indicate that it has been decommissioned and emptied of refrigerant
- the label must be dated and signed
- labels indicating the content of flammable refrigerant must be affixed to the machine.

3.3.18 Recovery

When discharging refrigerant from a system for maintenance or decommissioning reasons.

Check that:

- the refrigerant is removed safely
- only cylinders suitable for refrigerant recovery are used
- the number of cylinders required to hold the entire system charge is available
- all cylinders to be used are designed for the refrigerant recovered and labelled for that refrigerant (special refrigerant recovery cylinders)
- the cylinders are equipped with a pressure relief valve and well-functioning shut-off valves
- empty recovery cylinders are evacuated and, if possible, cooled before recovery
- the recovery equipment is in good working order, accompanied by a set of instructions at hand, and suitable for the recovery of flammable refrigerants
- a set of well-functioning calibrated scales is provided
- the pipes are complete with decoupling fittings that are leak-free and in good condition
- the recovery equipment is in good working order, has been properly maintained and the associated electrical components are sealed to prevent a risk of ignition in the event of refrigerant leakage. If in doubt, consult the manufacturer.

- the refrigerant is returned to the supplier in the correct recovery cylinders, accompanied by the relevant waste identification form
- different types of refrigerant are not mixed in the recovery units, especially in the cylinders
- if compressors or compressor oils are decommissioned, evacuate them to an acceptable level to prevent flammable refrigerant from remaining inside the lubricant
- the evacuation procedure is carried out before returning the compressor to the suppliers
- only the electric heating on the compressor body is used to accelerate this process
- when oil is extracted from the system, it is drained using a safe procedure.

3.3.19 Transportation, marking, storage and disposal of units

- comply with current national regulations.

3.3.20 Receipt and handling

On receipt of the unit:

- check if there is refrigerant inside the packaging using an electronic leak detector suitable for the system refrigerant
- if there is, it is likely that the refrigerant circuit is damaged
- In this case, the unit must not be installed and the Technical Support Service must be called.

3.4 Installation requirements

3.4.1 Total refrigerant charge in the system

- i** If the total refrigerant charge in the system is ≤ 1.84 kg, there are no minimum surface requirements.

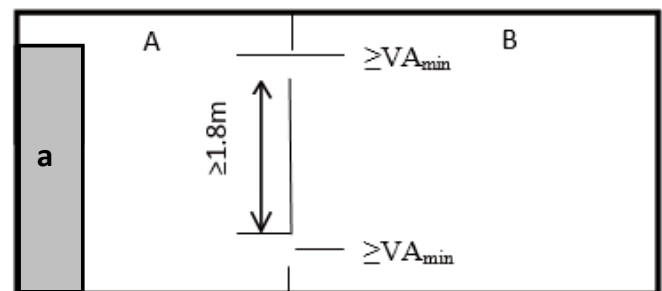

a Indoor unit.

A Room where the indoor unit is installed.

B Room adjacent to room A.

Area A+B must be greater than or equal to the minimum surface required in table 2 according to the total charge.

If the total refrigerant charge in the system is >1.84 kg, it is necessary to comply with the minimum surface requirements indicated in the following procedure.

- calculate, based on piping length, the total refrigerant charge (m_c)
- calculate the area of room A (A_{room A})
- calculate the maximum refrigerant charge allowed by room A (m_{max}) using table 1
- **if $m_{max} \geq m_c$, the unit can be installed in room A**

If $m_{max} \leq m_c$:

- calculate the area of room B adjacent to room A (A_{room B})
- calculate the minimum total area (A_{min total}) required for the total refrigerant charge (m_c) using table 2
- **if (A_{room A} + A_{room B}) \geq A_{min total}**
- calculate the minimum area of natural ventilation opening between room A and room B (according to the capacity of the outdoor unit) using table 3.1 or 3.2
- the unit can be installed in room A if:
 - there are 2 ventilation openings (permanently open) between room A and B, 1 in the upper part and 1 in the lower part
 - lower opening: the lower opening must fulfil the minimum area requirements (VA_{min}). It must be as close to the floor as possible. If the ventilation opening starts from the floor, the height must be ≥ 20 mm. The lower part of the opening must be less than 100 mm from the floor. At least 50% of the required opening area must be <200 mm from the floor. The entire opening area must be <300 mm from the floor
 - upper opening: the upper opening area must be greater than or equal to the lower opening. The lower part of the upper opening must be at least 1.5 m above the upper part of the lower opening
 - ventilation openings to the outside are NOT considered suitable ventilation openings (the user can close them when it is cold)
- **if (A_{room A} + A_{room B}) < A_{min total} call the dealer.**

Table 1

Maximum refrigerant charge allowed in a room: Indoor unit.

A _{room} [m ²]	Maximum refrigerant charge in Aroom [m _{max}] [kg]
	H = 600 mm
1	0,138
2	0,276
3	0,414
4	0,553
5	0,691
6	0,829
7	0,967
8	1,105

9	1,243
10	1,382
11	1,520
12	1,658
13	1,796
14	1,934
15	2,072
16	2,210
17	2,349
18	2,487

Check:

- H: is the release height; the vertical distance in millimetres from the floor to the lowest point of the unit when installed
- for H values lower than 600 mm, the H value considered is 600 mm to fulfil the requirements of IEC 60335-2-40:2018 Clause GG 2
- for intermediate A_{room} values, the corresponding lower A_{room} value should be considered. If A_{room} = 7.5 m² the area of the room A_{room} = 7 m² is considered
- systems with total refrigerant charge lower than or equal to 1.84 kg are not subject to these requirements.

Table 2

Minimum surface: Indoor unit.

m _c [kg]	Minimum floor area [m ²] (A _{min total})
	H = 600 mm
1,84	13,319
1,86	13,464
1,88	13,608
1,9	13,753
1,92	13,898
1,94	14,043
1,96	14,187
1,98	14,332
2	14,477
2,02	14,622
2,04	14,767
2,06	14,911
2,08	15,056
2,1	15,201
2,12	15,346
2,14	15,490
2,16	15,635
2,18	15,780
2,2	15,925
2,22	16,069

2,24	16,214
2,26	16,359
2,28	16,504
2,3	16,649
2,32	16,793
2,34	16,938
2,36	17,083
2,38	17,228
2,4	17,372
2,42	17,517

Check:

- for H values lower than 600 mm, the H value considered is 600 mm to fulfil the requirements of IEC 60335-2-40:2018 Clause GG 2
- for intermediate m_c values, the corresponding higher m_c value should be considered. If $m_c = 2.07$ kg, $m_c = 2.08$ kg is considered
- systems with total refrigerant charge lower than or equal to 1.84 kg are not subject to these requirements
- charges above 1.80 kg are not allowed in sizes 2.1 and 3.1
- charges above 2.22 kg are not allowed in sizes 4.1 and 5.1
- charges above 2.41 kg are not allowed in sizes 6.1, 7.1 and 8.1.

Table 3.1

Minimum opening area for natural ventilation: For units with a capacity of 8 to 10 kW.

m_c [kg]	m_{max} [kg]	Minimum venting opening area [cm ²] [VA _{min}]
		H = 600 mm
2,22	0,1	1026
2,22	0,3	928
2,22	0,5	832
2,22	0,7	735
2,22	0,9	638
2,22	1,1	542
2,22	1,3	445
2,22	1,5	348
2,22	1,7	251
2,22	1,9	138
2,22	2,1	52

Check:

- for H values lower than 600 mm, the H value considered is 600 mm to fulfil the requirements of IEC 60335-2-40:2018 Clause GG 1
- for intermediate m_{max} values, the corresponding higher m_{max} value should be considered.
If $m_{max} = 0.6$ kg, $m_c = 0.7$ kg is considered.

Table 3.2

Minimum opening area for natural ventilation: For units with a capacity of 12 to 16 kW.

m_c [kg]	m_{max} [kg]	Minimum venting opening area [cm ²] [VA _{min}]
		H = 600 mm
2,41	0,1	1118
2,41	0,3	1020
2,41	0,5	924
2,41	0,7	827
2,41	0,9	730
2,41	1,1	633
2,41	1,3	537
2,41	1,5	440
2,41	1,7	343
2,41	1,9	247
2,41	2,1	150
2,41	2,3	48

Check:

- for H values lower than 600 mm, the H value considered is 600 mm to fulfil the requirements of IEC 60335-2-40:2018 Clause GG 1
- for intermediate m_{max} values, the corresponding higher m_{max} value should be considered
if $m_{max} = 0.6$ kg, $m_c = 0.7$ kg is considered.

4. Presentation of the product

4.1 Identification

The serial number label is positioned on the unit and allows to identify all the unit features.

The matriculation plate shows the indications foreseen by the standards, in particular:

- unit type
- serial number
- year of manufacture
- wiring diagram number
- electrical data
- manufacturer logo and address

i The serial number uniquely identifies each unit and enables specific parts to be identified.

! Tampering, removal, missing identification labels or anything else that does not allow the product to be safely identified, makes installation and maintenance operations difficult.

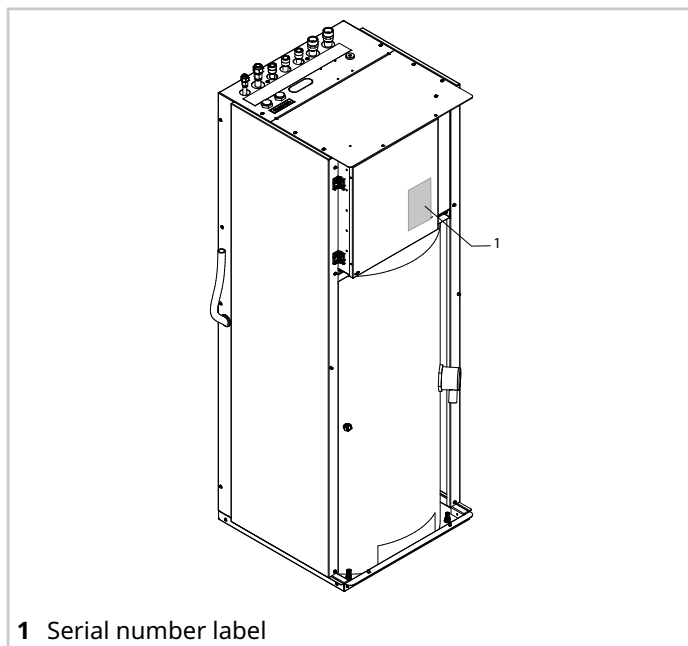

4.2 Regulatory framework

The relevant regulatory framework can be found in the declaration of conformity enclosed with this document.

4.3 Intended use

The units are designed for:

- indoor installation of SQKN-YEE 1 TC
- operation within the limits and with their performance characteristics set out in this document.

4.4 Description

Refrigerant-split heat pump indoor unit with integrated DHW tank.

4.5 Combinations

Outdoor unit that can be combined:

- **MiSAN-YEE 1 S**

4.6 Main components

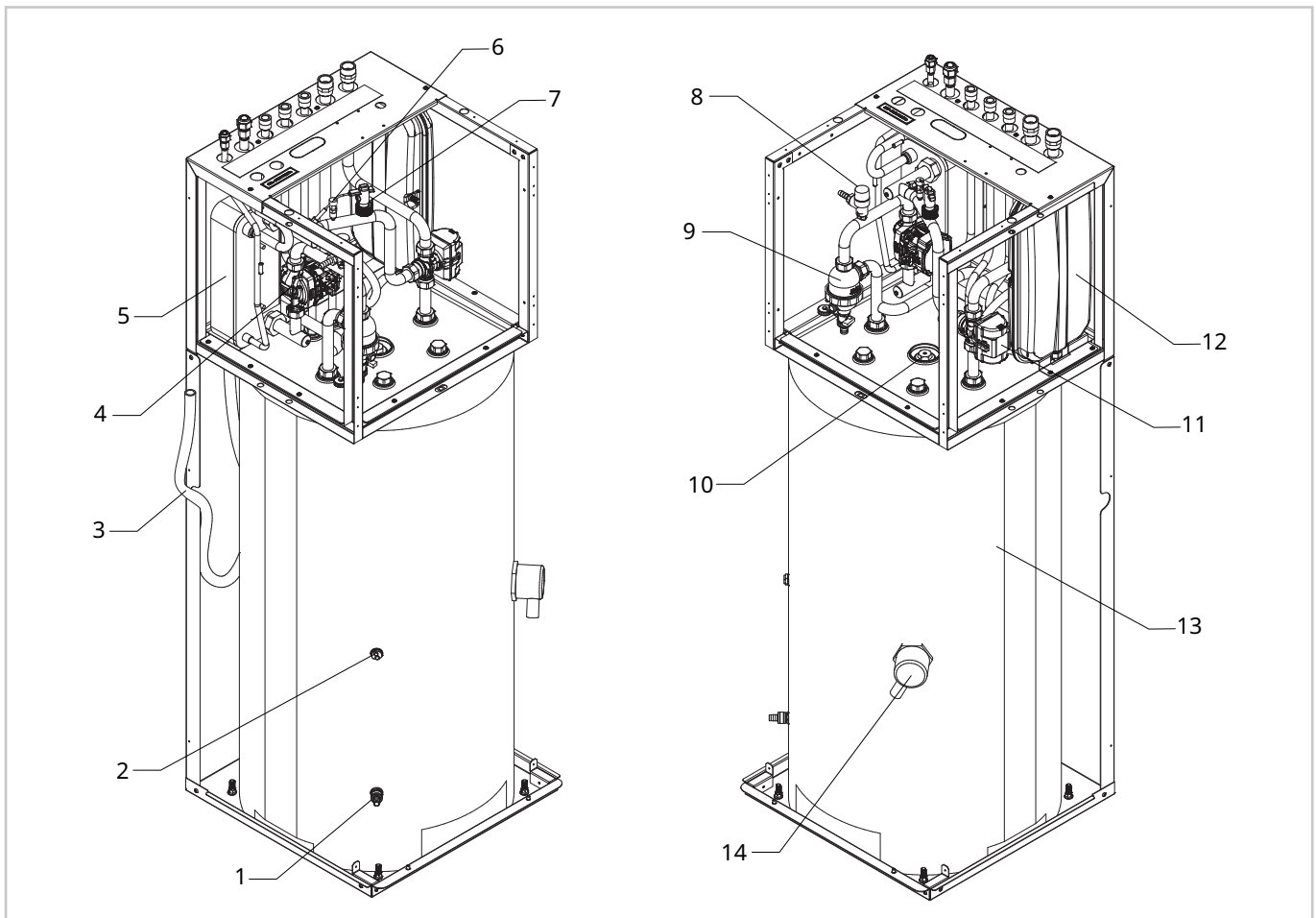

No.	Component
1	Tap
2	DHW probe Solar probe (option)
3	Condensate drain
4	System circulator
5	System exchanger
6	System vent valve
7	Flow switch
8	System pressure relief valve
9	Sludge
10	Anode
11	DHW / system production valve
12	System expansion tank
13	Heater (2 kW)
14	Storage tank

 The images are provided for illustrative purposes only.

4.7 Components supplied with the unit

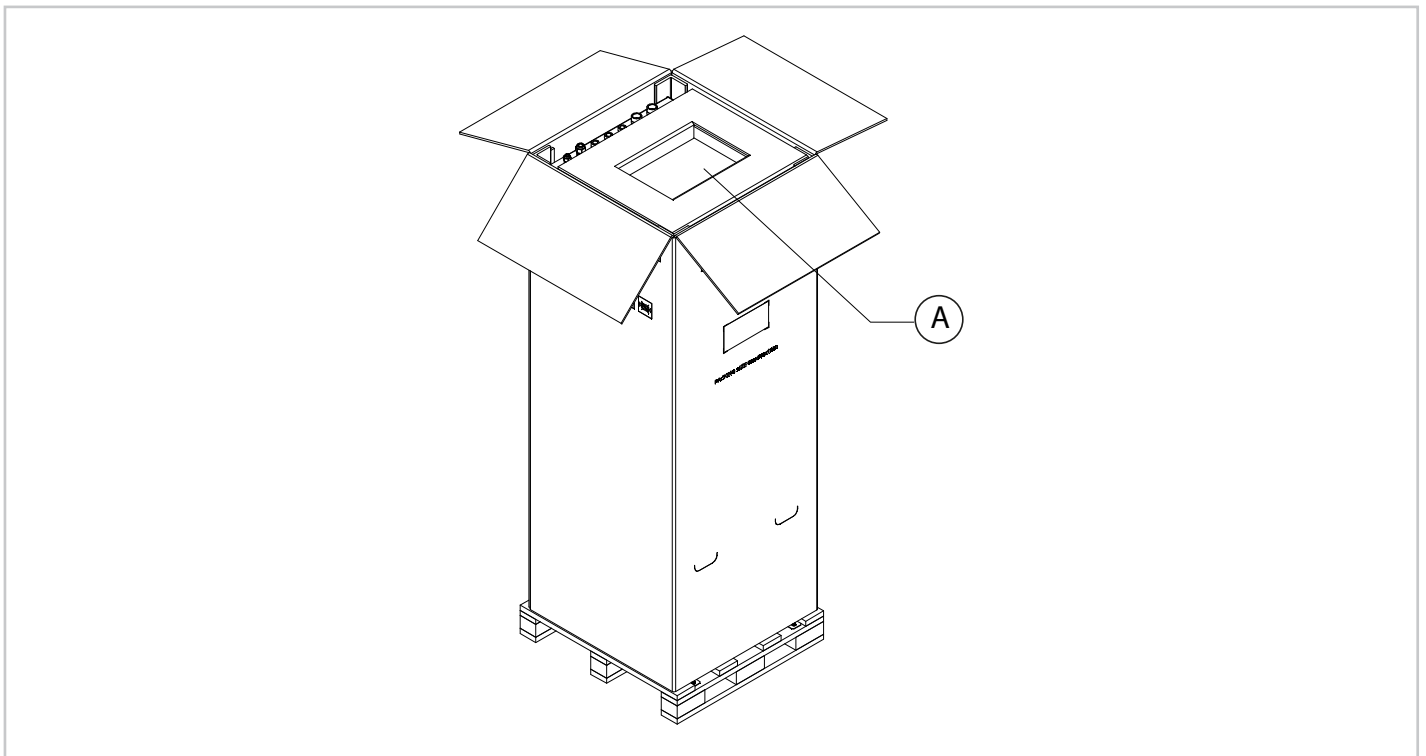

A Position of components supplied with the unit

The following components can be found in the package:













Description	Quantity
Installation and maintenance manual	1
Water filter	1
Fittings to be welded	1
TORX key	1
Water tap	1
Copper reduction 10-6	1
Insert	1

4.8 Compatible accessories

The list of accessories can be found in the technical bulletin.

5. Before installation

5.1 Prerequisites

-  This section is intended exclusively for the Installer.
-  Refer to the Technical data chapter for details.
-  Follow the safety instructions in the "About R-32 refrigerant" chapter on page 9.
-  When handling the unit, use equipment appropriate to the weight of the unit.
-  Check that all handling equipment complies with local safety regulations (cran, forklifts, ropes, hooks, etc.).
-  During manual operations, it is mandatory to comply with the maximum weight per person as required by current legislation.
-  Provide personnel with personal protective equipment appropriate for the situation, such as hard hat, gloves, safety shoes, etc.
-  Observe all safety procedures in order to guarantee the safety of the personnel present and the of material.
-  To avoid injury, do not touch the unit's air inlet or aluminium fins.
-  Do not use the fan grille handles to move the unit.
-  Keep the unit packed during handling.
-  Remove the packaging when you have reached the point of installation.

5.2 Reception

Before accepting the delivery, check:

- that the unit has not been damaged during transport
- that the materials delivered match those indicated on the transport document, comparing the data with the serial number label on the packaging.

In case of damage or anomaly:

- immediately write down the damage found on the transport document and quote this sentence: "Accepted with reservation due to evident shortages/damages during transport"
 - refer to the contractual document.
-  Any disputes must be made within 8 days from the date of the delivery. Complaints after this period are invalid .

5.3 Storage

Respect the indications on the outside of the pack.

In particular:

- minimum ambient temperature $-10\text{ }^{\circ}\text{C}$
 - maximum ambient temperature $+50\text{ }^{\circ}\text{C}$
 - maximum relative humidity 95%
-  Exceeding these limits can cause irreversible damage to the unit.

5.4 Handling

The unit can be handled:

- with a forklift truck or pallet truck.

The following examples are guidelines; the choice of means and handling modes will depend on the actual installation situation.

Lifting with a forklift truck

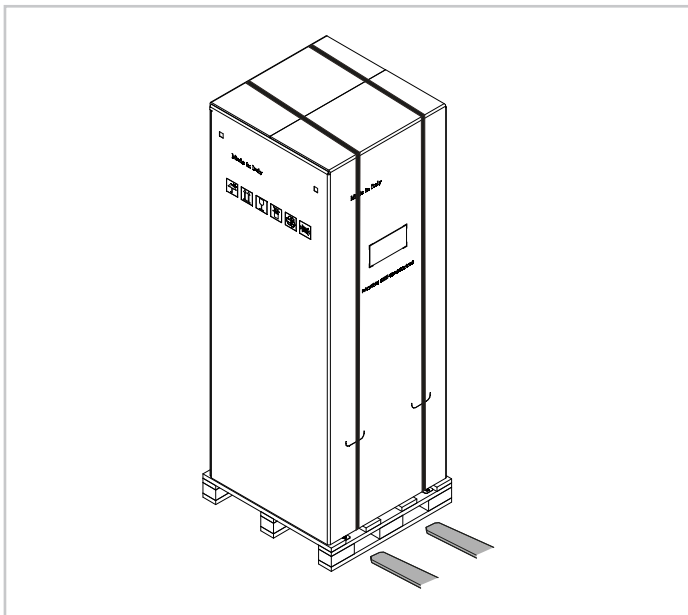

- ⚠ When the load is lifted off the ground, stay clear of the area below and around it.
- ⚠ Identify critical points during handling (disconnected routes, flights, steps, doors).
- ⚠ Before starting the handling, make sure that the unit is stable.

5.5 Removal of the packaging

On reaching the installation site.

Carry out the following procedure:

- ▶ cut the straps

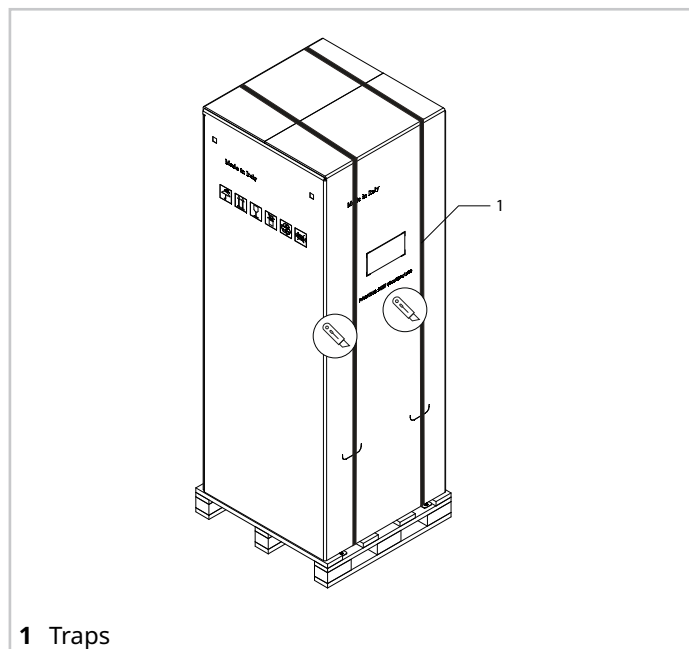

1 Traps

- ▶ lift and remove the packaging

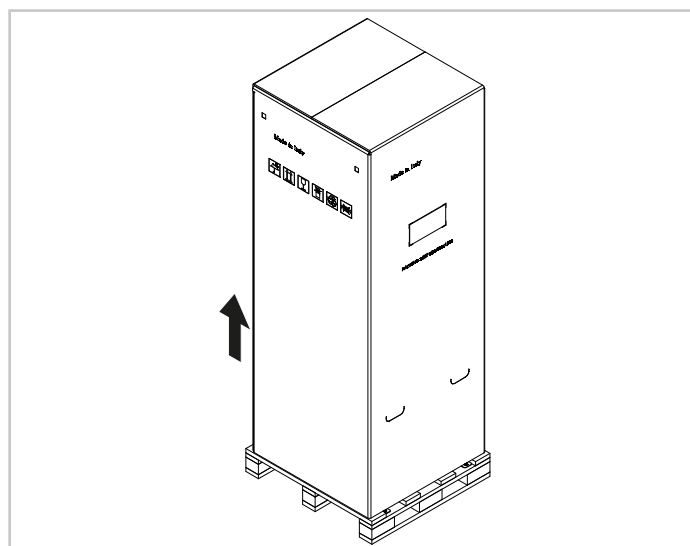

remove the protection elements

- ▶ remove the components supplied

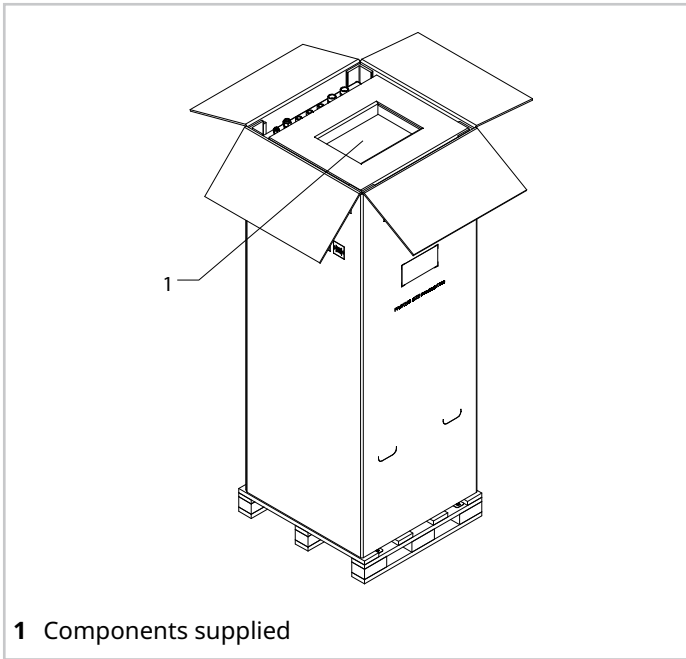

► remove the fixing screws from the pallet

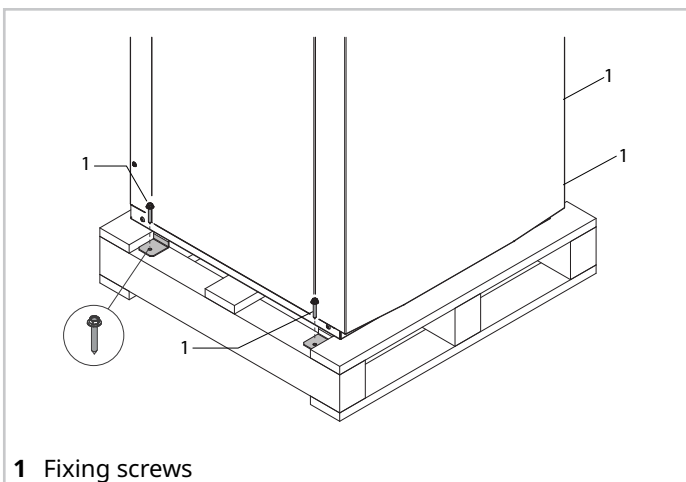

► move the brackets

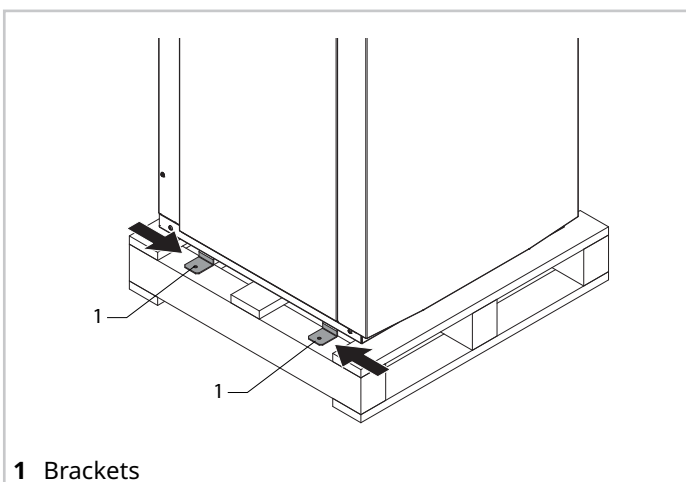

► remove the brackets

► remove the unit with suitable means

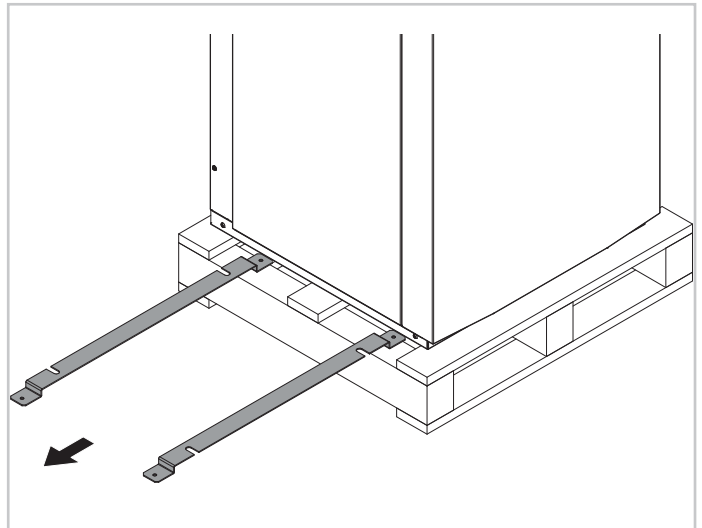





⚠ Be careful not to damage the unit.

⚠ Keep the packaging material out of children's reach as it may be dangerous.

⚠ Recycle and dispose of the packaging material in conformity with local regulations.

6. Installation

6.1 Prerequisites

-  This section is intended exclusively for the Installer.
-  Refer to the Technical data chapter for details.
-  The electrical system and its components must be designed by a qualified technician who must work according to the rules of good practice and national regulations.
-  **Ensure that:**
 - the room or the compartment is dry and the room temperature cannot fall below 0°C or rise above 35°C
 - any furniture or other objects can be moved easily in the event of maintenance
 - the location can be accessed safely
 - the clearances are guaranteed
 - the support surface or the wall can withstand the weight of the unit
 - the floor or wall section does not interfere with power lines or water piping and no load-bearing elements of the construction are compromised.
-  **Avoid therefore:**
 - places that may be subject to flooding

6.2 General diagram

Positioning

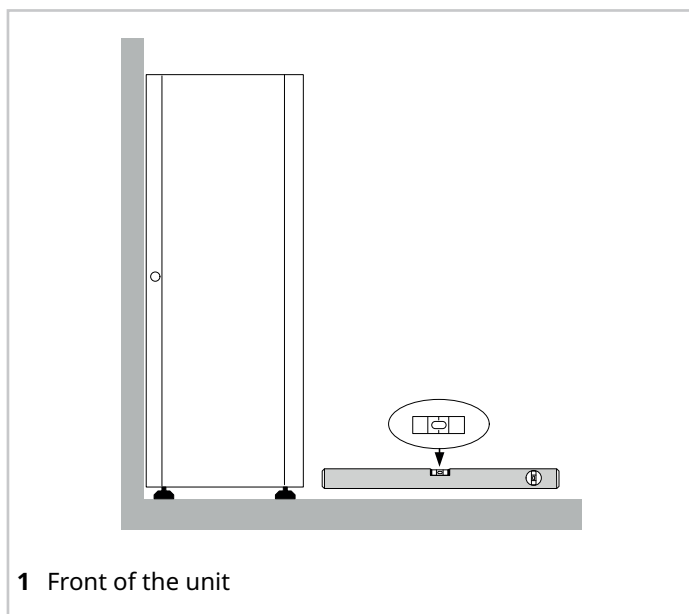

- ▶ position the unit on a flat surface
- ▶ lean the back against a wall

Levelling

▶ adjust the support feet

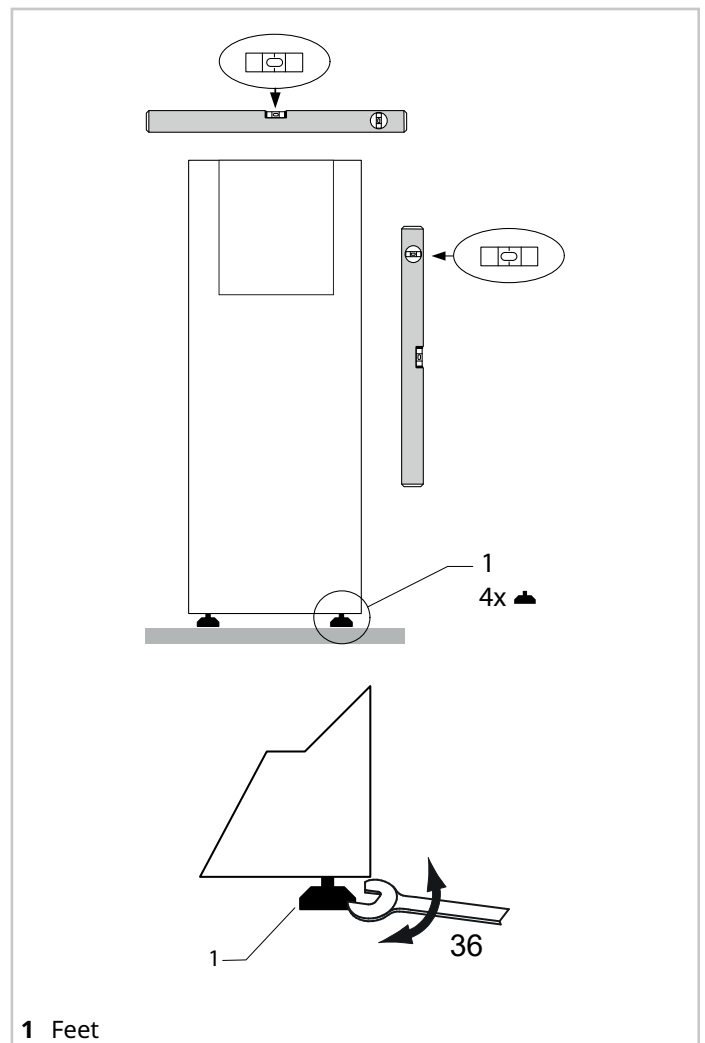

6.3 Clearances

The clearances for installation and maintenance of the unit are shown in the figure.

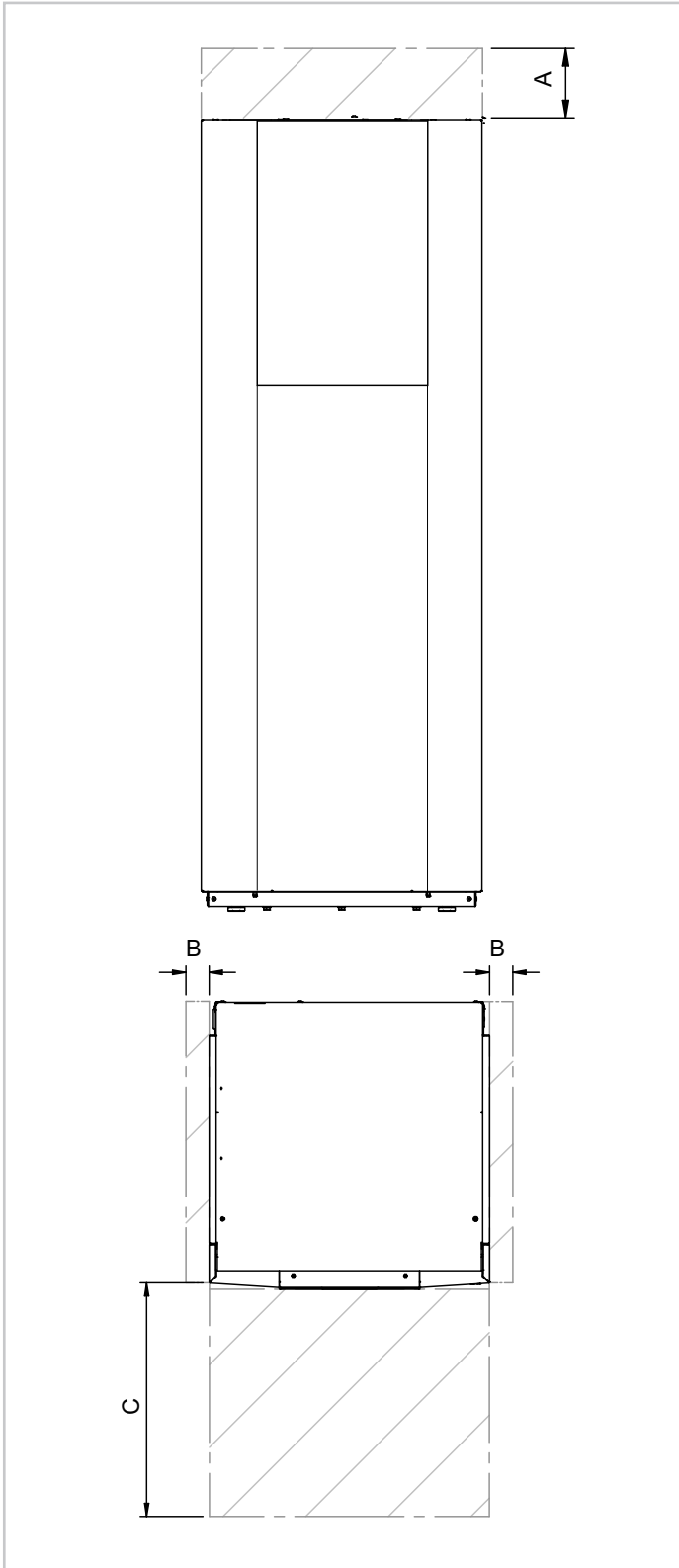

A	mm	250
B	mm	50
C	mm	500

6.4 Access to internal parts

The unit has removable access panels.

- unscrew the fixing screws

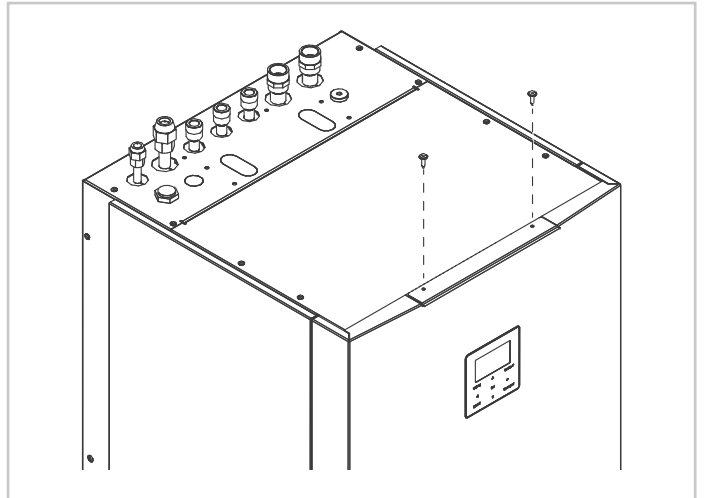

- remove the access panel

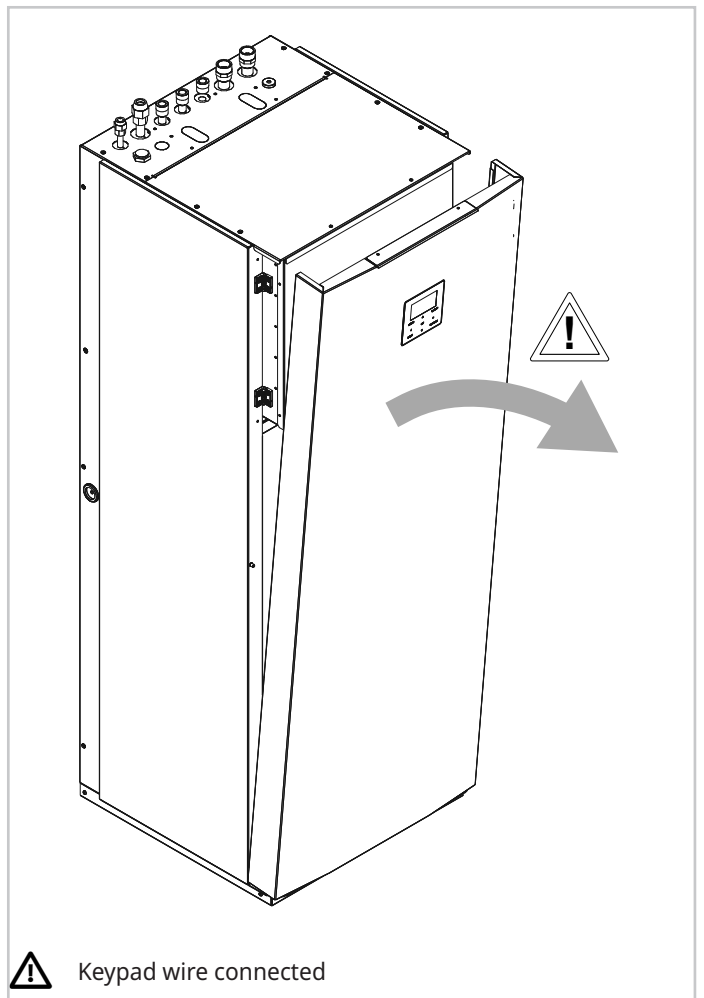

To access the components behind the electrical panel:

- ▶ unscrew the fixing screws
- ▶ remove the side panel
- ▶ same sequence for the opposite side

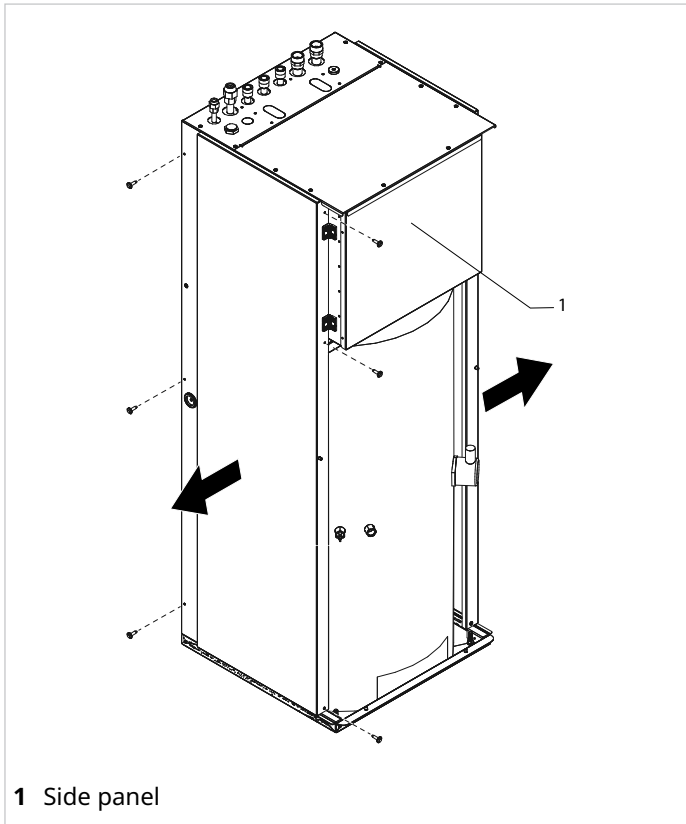

- ▶ unscrew the knobs
- ▶ rotate the electrical panel

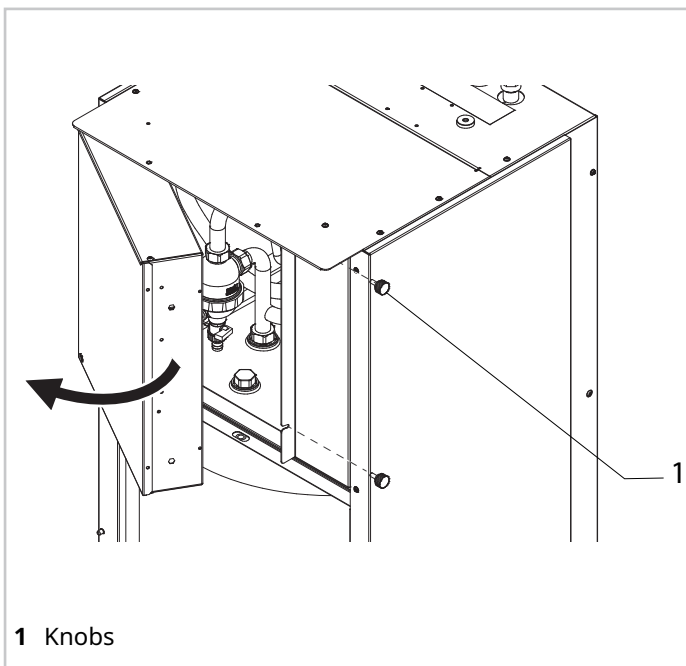

Access to the electrical panel

- ▶ unscrew the fixing screws
- ▶ remove the electrical panel access panel

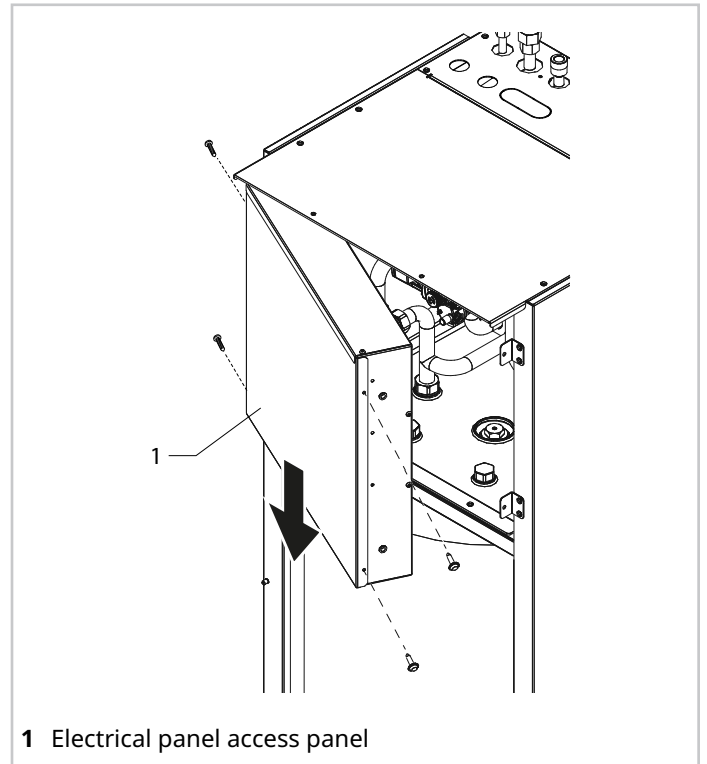

To refit:

- ▶ repeat the operations in reverse order

7. Water connections

7.1 General system diagram example

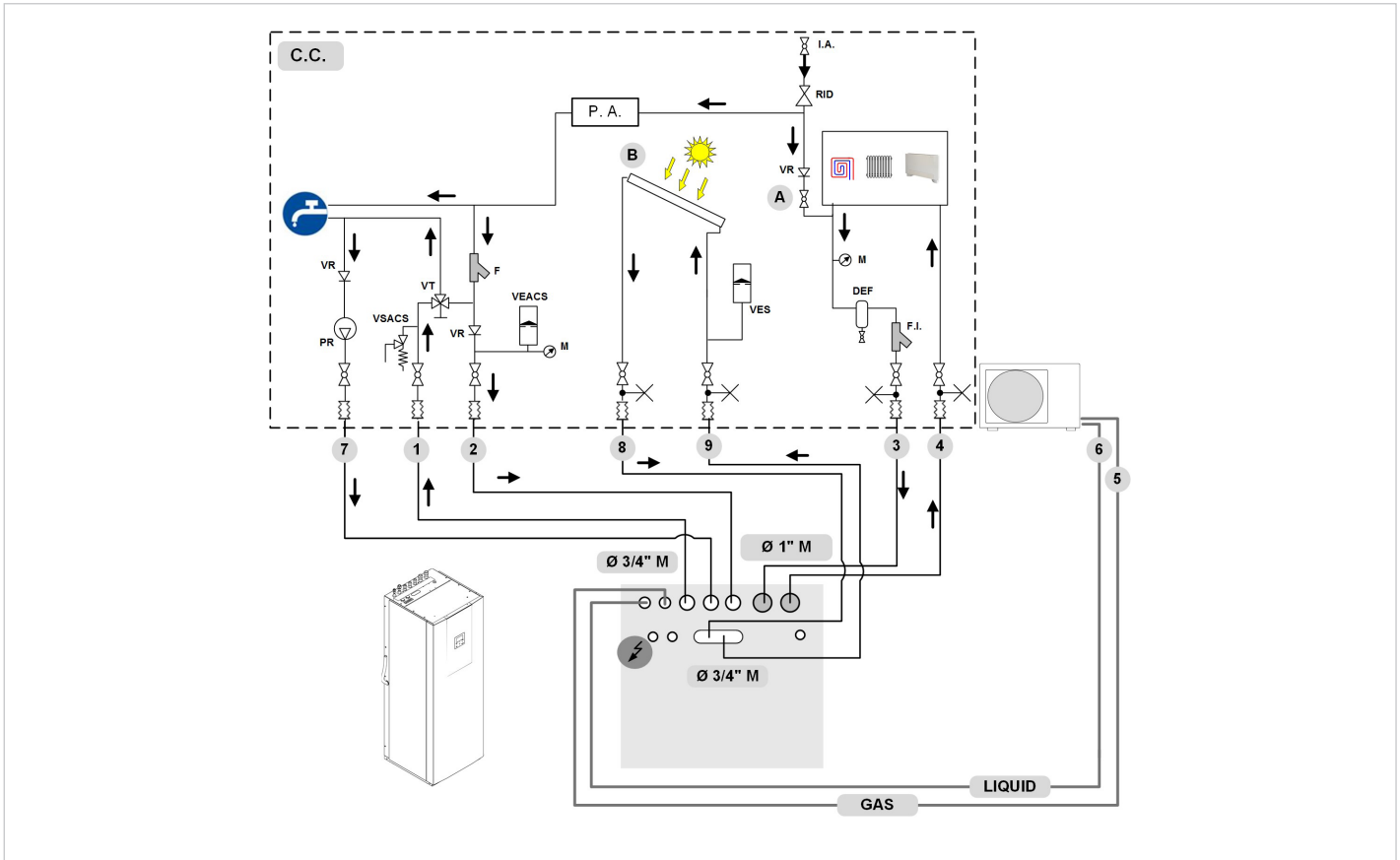





i The system components must be defined by the Designer and Installer

Indispensable components system (not supplied)

C.C.	Components provided by Customer	1	Domestic hot water outlet
A	System valve	2	Aqueduct inlet
B	Elfosun 2 (option)	3	System water return
I.A.	Aqueduct inlet	4	System water supply
F	Water filter (supplied)	5	Refrigerant line (gas)
F.I.	System filter (provided by the customer)	6	Refrigerant line (liquid)
M	Pressure gauge	7	Domestic water circulation
P.A.	Descaler protection	8	Return from solar system (option)
PS	Solar pump	9	Supply to solar system (option)
PR	DHW recirculation pump	10	Solar system return (option)
RID	Pressure reducing valve	11	Solar system outlet (option)
VEACS	Domestic hot water expansion tank		Vent
VSACS	DHW pressure relief valve		Cut-off valves
VES	Solar expansion tank		Anti-vibration joints
VR	Check valve		
VT	Thermostatic mixing valve		

7.2 Prerequisites

-  This section is intended exclusively for the Installer.
-  Refer to the Technical data chapter for details.
-  Follow the safety instructions in the "About R-32 refrigerant" chapter on page 9.
-  The hydraulic system and its components must be designed by a qualified technician who must work according to the rules of good practice and national regulations.
-  **Check that:**
 - the maximum water pressure and temperature are compatible with the operating limits of the unit
 - discharge shut-off valves are installed at the lowest points of the system so that the circuit can be completely drained during maintenance
 - air vents are installed at the highest points of the system, in easily accessible places
 - the unit is only connected to closed hydraulic circuits.



7.3 Water flow-rate

The design water flow-rate must be:

- inside the exchanger operating limits (see chapter Technical information)
- guaranteed also with variable system conditions (for example, in systems where some circuits are bypassed in particular situations).

7.4 Minimum water content

Check that:

- the system complies with the minimum water content (see the Technical Information chapter)
-  In process applications or in environments with high thermal load, additional water may be required.
-  When the system has areas with remotely controlled valves, the minimum water volume must be guaranteed even when all valves are closed.

7.5 Water characteristics

The quality of the water used must be in accordance with the requirements in the following table, otherwise a treatment system must be provided.

Water component for corrosion limit on Copper	
PH (25°C)	7,5 ÷ 9,0
SO ₄ ⁻	< 100
HCO ₃ ⁻ / SO ₄ ⁻⁻	> 1
Total Hardness	8 ÷ 15 °f (4.5-8.5 dH)
Cl-	< 50 ppm
PO ₄ ³⁻	< 2,0 ppm
NH ₃	< 0,5 ppm
Free Chlorine	< 0,5 ppm
Fe ₃ ⁺	< 0,5 ppm
Mn ⁺⁺	< 0,05 ppm
CO ₂	< 50 ppm
H ₂ S	< 50 ppm
Temperature	< 80 °C
Oxygen content	< 0,1 ppm
Sand	10 mg /L 0,1 to 0,7 mm max diameter
Ferrite hydroxide Fe ₃ O ₄ (black)	Dose < 7,5 mg/L 50% of mass with diameter < 10 µm
Iron oxide Fe ₂ O ₃ (red)	Dose < 7,5 mg/L - Diameter < 1 µm





7.6 Cleaning

Before connecting the unit to the system:

- clean the system thoroughly with specific products to remove residues or impurities that could affect operation.
-  The warranty does not cover damage caused by limescale build-up, deposits and impurities in the water and/or failure of the hydraulic circuit cleaning system.

Existing systems

If a new unit is installed in an existing system:

- the system must be flushed thoroughly to eliminate any particles, sludge and waste.
-  The system must be cleaned before installing the new unit.
-  Dirt can be removed only with a suitable water flow rate.
-  Each section must be cleaned separately.
-  Pay particular attention to "blind spots", where a lot of dirt can accumulate due to the reduced flow-rate.

- ⚠ If necessary, install an additional filter sized according to the type of pollutant to be removed.

7.7 Piping insulation

Isolate the entire hydraulic circuit, including all components to avoid:

- the formation of condensation during cooling
- the reduction of heating and cooling capacity
- the freezing of external water pipes in winter.

7.8 Hydraulic circuit antifreeze protection

Outdoor temperatures close to zero can cause the water in the piping and in the unit to freeze.

- ⚠ Frost can lead to irreversible damage to the unit.
- ⚠ Damage from freezing is not covered by the warranty.

To avoid freezing problems:

- mix the water with glycol, or:
 - protect the piping with heating cables laid under the insulation, or
 - empty the system in the event of long downtime
- ⚠ If the unit is not started for a long time, make sure it powered on and stand-by.
 - ⚠ If the power supply has to be disconnected water in the circuit must be drained so that the unit and piping are not damaged by freezing.
 - ⚠ Do not reconnect the unit if there is no water in the circuit.
 - ⚠ In the event of an electric leakage or power failure, the freezing protection functions cannot be activated.

7.8.1 Antifreeze solutions

For the use of freezable solutions, follow the manufacturer's instructions.

- i* The use of unfreezable solutions causes an increase in pressure drops and a reduction in performance.
- i* For details, refer to the technical bulletin.
- ⚠ The type of glycol used must be inhibited (non-corrosive) and compatible with the hydraulic circuit components.
- ⊖ Do not use different glycol mixtures (e.g. ethylene with propylene).
- ⚠ Glycol is a toxic fluid, should not be discharged freely it must be collected and possibly reused.

7.9 Position of connections

Rear view.

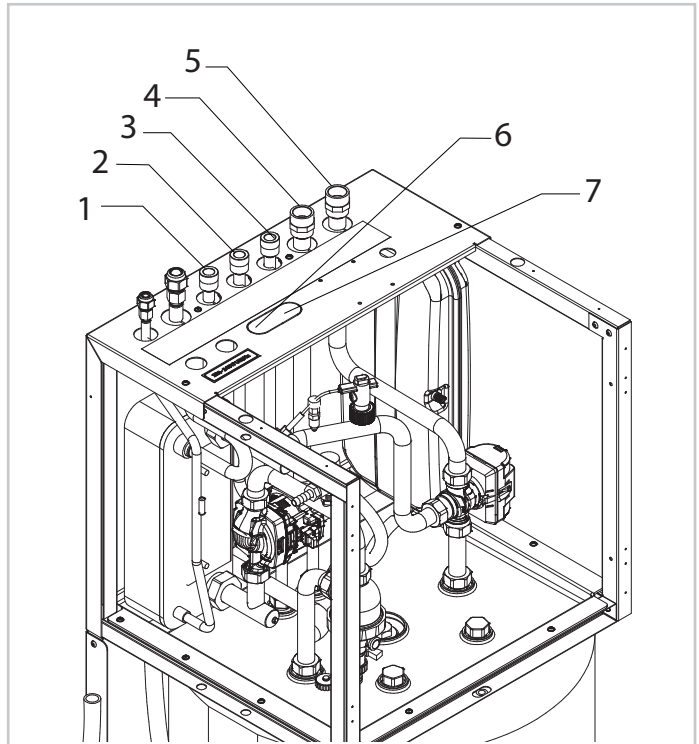

- 1 Domestic hot water outlet Ø 3/4"
- 2 Domestic hot water (DHW) circulation input Ø 3/4"
- 3 Water supply system inlet Ø 3/4"
- 4 Return from system Ø 1"
- 5 Supply to system Ø 1"
- 6 Solar system outlet Ø 3/4" (optional)
- 7 Solar system inlet Ø 3/4" (optional)

7.10 Hydraulic connection

Ensure that:

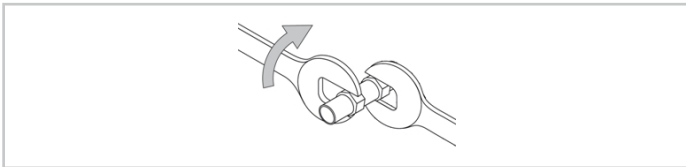

- clean piping with no moisture, air, dirt or dust is used
- the end of the pipe is kept downwards when removing burrs
- the end of the pipe is covered when passing it through a wall to prevent dust and dirt from entering
- thread sealant is used to seal the connections that must withstand the pressures and temperatures of the circuit
- the two types of materials are isolated from each other to prevent galvanic corrosion when using non-copper metal piping
- the piping is not deformed by using excessive force or unsuitable tools during connection: this could cause the unit to malfunction.

 Always use the wrench and counter wrench method in tightening operations.





7.11 Water filter

A water filter is supplied with the unit.

-  Installation of the filter is mandatory.
-  Operation without a filter can cause irreversible damage to the unit.
-  Operation without a filter will void the warranty.

Remember that the filter must be:

- installed immediately at inlet to the water supply system
- easily accessible for maintenance work
-  Periodically check for clogging.
-  The filter should never be removed.

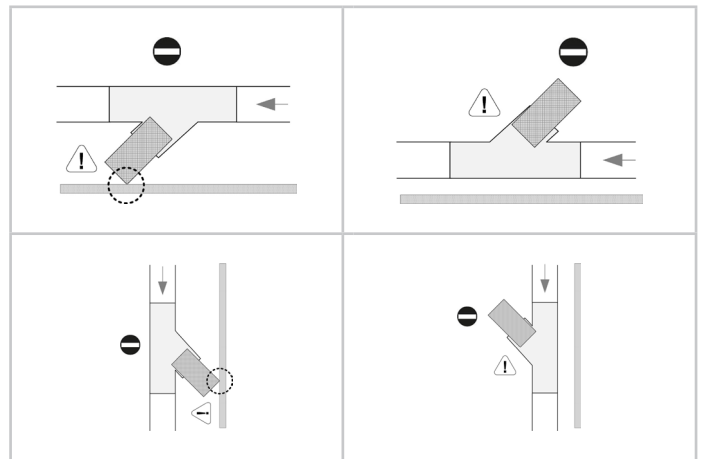
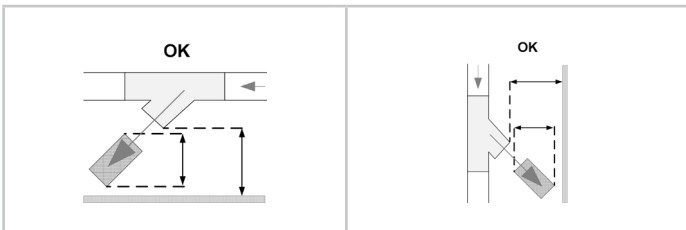



7.12 System filter



Provided by the customer

Use a stainless steel mesh filter:

- 0.5 mm (500 mesh)

-  Operation without a filter can cause irreversible damage to the unit.
-  Operation without a filter will void the warranty.

Remember that the filter must be:

- installed immediately on system return
- easily accessible for maintenance work
-  Periodically check for clogging.
-  The filter should never be removed.

7.13 DHW safety valve

⚠ Inside the unit there is one pressure relief valve (6 bar on the system circuit) and one to be installed on the DHW outlet (6 bar on the DHW circuit) which must be connected to a suitable drain, otherwise if the valves trip and flood the rooms, the heat pump manufacturer will not be liable.

⚠ Antifreeze liquid, if used in the system or solar circuit, should not be discharged freely as it is a pollutant. It must be collected and reused.

Pressure relief valve connection

- ▶ connect the pipe to the pressure relief valve
- ▶ direct the exhaust pipe towards a suitable drain

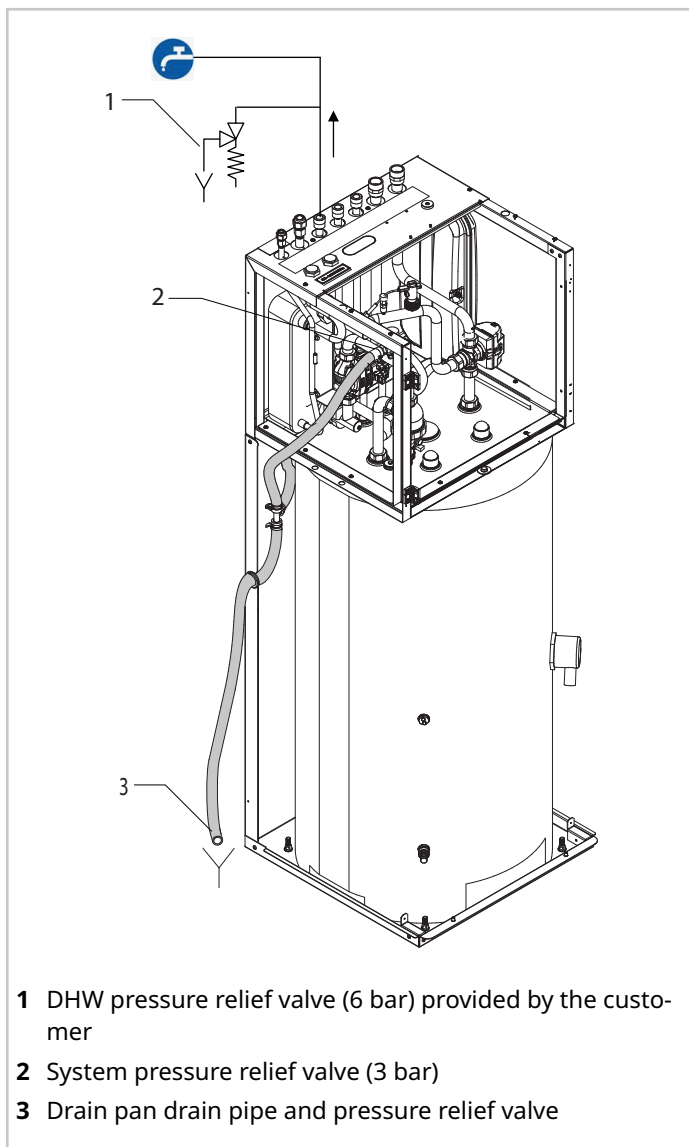

7.14 Relief valves

Install them at all the highest points of the piping in order to vent air from the circuit.

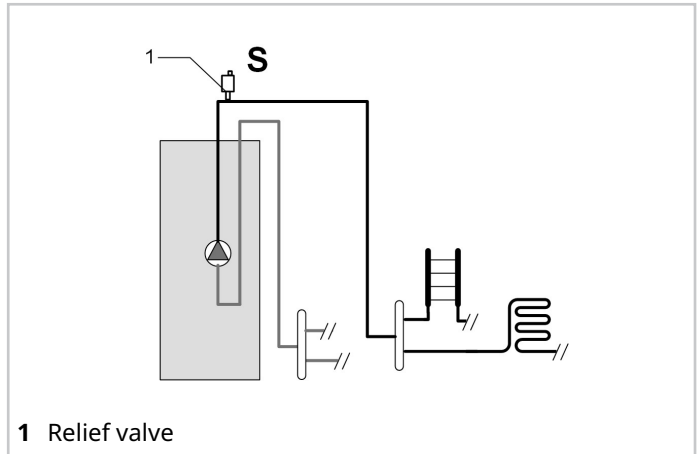

7.15 DHW tank filling

⚠ Fill the water tank (DHW) only during unit start-up. If the home is not immediately lived in or the unit is turned off for long periods, empty the water tank to avoid water stagnation, or with temperatures close to 0°C the risk of frost.

Once the hydraulic connections have been completed, the DHW tank can be filled.

Before charging:

- ▶ turn the system's main switch off
- ▶ check that the system shut-off valve is closed

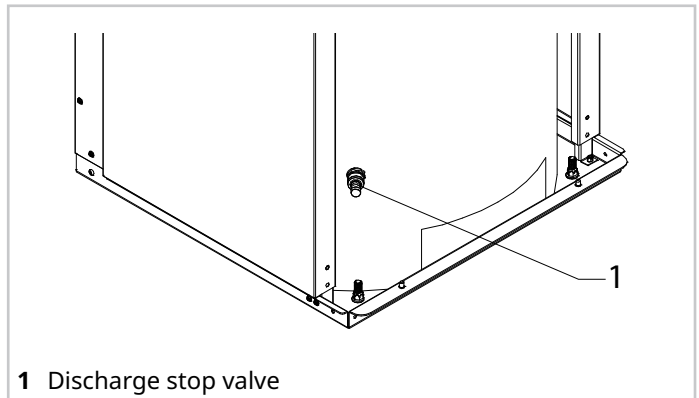

To fill the water tank:

- ▶ start filling, slowly opening the water shut-off valve
- ▶ open the taps located on the DHW outlet system, DHW circulation and water supply system inlet
- ▶ open the hot water taps (bathroom and kitchen)

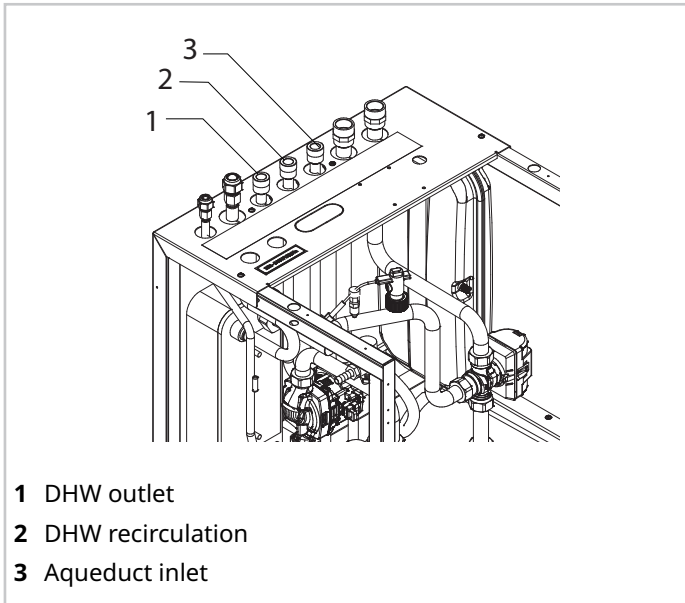

When water starts coming out of the taps:

- ▶ close the taps (bathroom and kitchen)
- ▶ continue filling up to the system pressure value
- ▶ check the hydraulic seal of the joints

⚠ Maximum DHW system pressure 6 bar

⚠ DHW safety valve setting 6 bar

7.16 Loading the plant

Once the hydraulic connections have been completed, the system can be charged.

Position of the 3-way relief valve

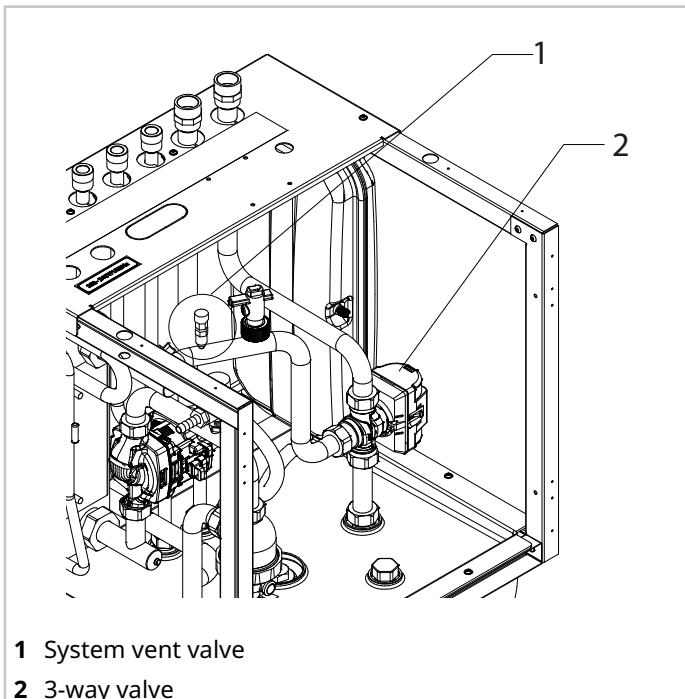

Before charging, the 3-way valve lever must be correctly positioned.

Proceed as follows:

- ▶ the unit must be powered
- ▶ on the keypad set DHW mode to ON
- ▶ wait until the 3-way valve lever is at the top
- ▶ power off the unit

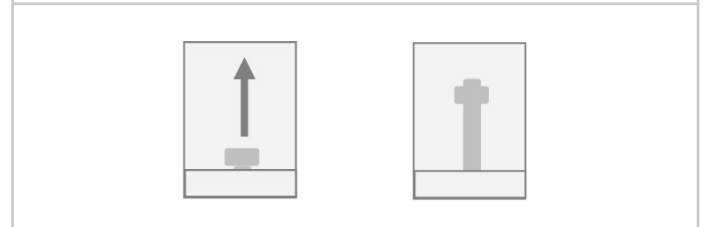
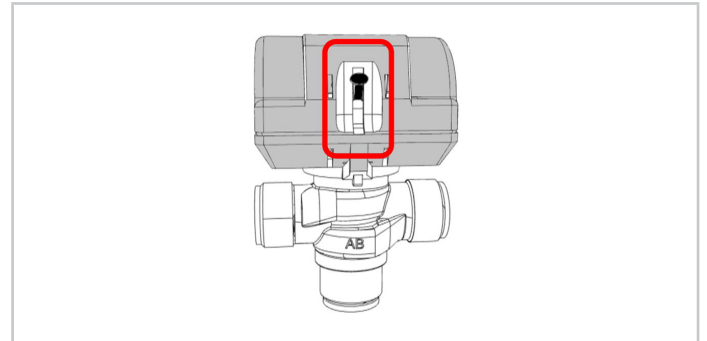

- ▶ press on the lever and move it to the centre until it locks

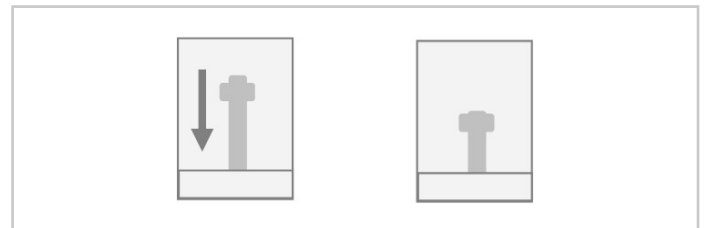





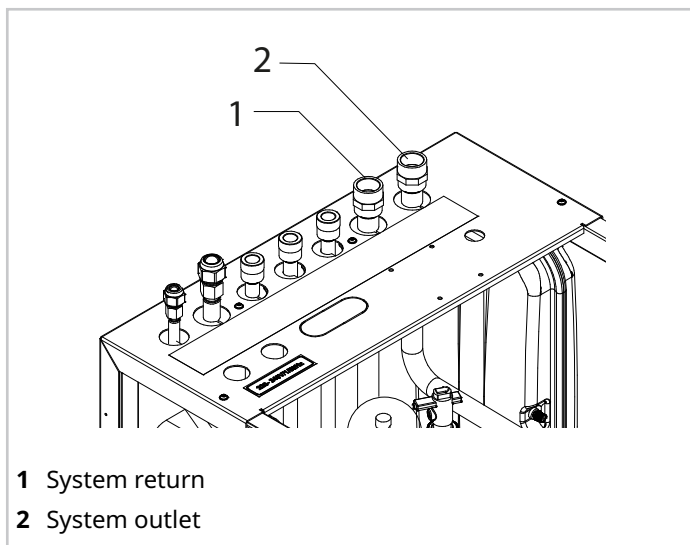

Charging the system:

- ▶ open the filling tap on the system (refer to the General system diagram)
- ▶ open all of the system and terminal relief valves

When water starts coming out of the air relief valves:



















- ▶ close the valves
- ▶ continue filling up to the system pressure
- ▶ check the hydraulic tightness of the connections.



-  Check the system pressure periodically.
-  Reintegration is carried out when the unit is off (pump OFF).
-  If the system remains charged and inoperative at outside temperatures close to zero, freezing problems may occur.
-  Refer to the Hydraulic Circuit Frost Protection chapter.
-  During installation, use and maintenance operations, the motor must NOT be removed.
-  In case of extraordinary maintenance see chapter MAINTENANCE.

8. Refrigerant connections

8.1 Prerequisites

-  This section is intended exclusively for the Installer.
-  Refer to the Technical data chapter for details.
-  Follow the safety instructions in the ["About R-32 refrigerant"](#) chapter on page 9.
-  The refrigerant piping and its components must be designed by a qualified technician who must work according to the rules of good practice and national regulations.
-  This unit is a subset and must be combined with another unit in order to function.
-  Comply with the PED Directive and the national regulations implementing the PED Directive.
-  Consider the activation of any additional safety devices.
-  Check operation of the safety devices.
-  Indicate on the serial number label the total amount of refrigerant.
-  Issue the declaration of conformity.
-  Inform the user of the need to carry out regular checks.
-  Only use copper piping specific for R32 refrigeration.
-  An incorrect sizing can cause damage to the compressor or variations in the cooling performance.
-  Piping should be cleaned and sealed at the ends.
-  Clean with nitrogen or dry air before connecting the piping to the two units.
-  Do not use piping with a different diameter.
-  Do not use used refrigerant piping, the flare connection seal is not ensured.
-  Do not make connections using hydraulic piping.
-  Do not weld with the presence of refrigerant in the piping.

 **Ensure that:**

- the piping route is as straight as possible, limiting the presence of bends, in order to achieve maximum system efficiency
- the piping is properly insulated
- when installing shut-off devices (solenoid valves, taps,

etc.), attention is paid to the possibility of installing refrigerant traps, i.e. closed upstream and downstream areas where the refrigerant cannot expand freely

- in this situation, the expansion of the trapped gas could cause an explosion in the refrigerant piping if the temperature rises (exposure to sun, piping close to heat sources, etc.). Consider installing a pressure relief valve, especially in the liquid piping which is potentially exposed to this risk.

 **Avoid therefore:**

- bends with too small a radius
- crushing piping
- passing through particularly silent environments.

8.2 Connection

⚠ For refrigerant connection operations, refer to the manual for the combined outdoor unit.

8.2.1 Refrigerant fittings

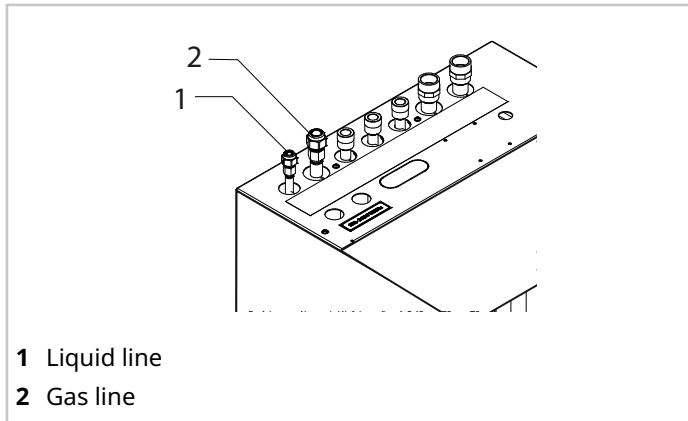

Refrigerant piping size	
Size	2.1-8.1
Liquid fitting	3/8" *
Gas fitting	5/8"

* Reduction 10-6 required for size 2.1-3.1 outdoor units, supplied





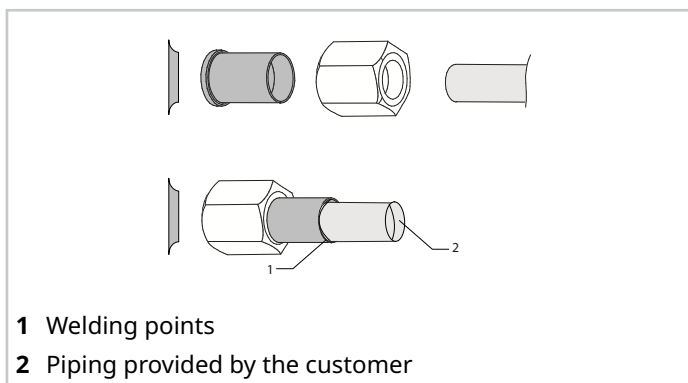





















Tightening torque		
Outdoor Ø	Tightening torque (N.cm)	Additional tightening torque (N.cm)
1/4"	1500 (153 kgf.cm)	1600 (163 kgf.cm)
3/8"	2500 (255 kgf.cm)	2600 (265 kgf.cm)
5/8"	4500 (459 kgf.cm)	4700 (479 kgf.cm)

Use the components supplied with the unit or perform flaring to make the connections.



9. Electrical connections

9.1 Prerequisites

-  This section is intended exclusively for the Installer.
-  The electrical system and its components must be designed by a qualified technician who must work according to the rules of good practice and national regulations.
-  All electrical operations should be performed by trained personnel having the necessary requirements by the regulations in force and being informed about the risks relevant to these activities.
-  Operate in compliance with safety regulations in force.
-  The power cables and the protection cable section must be defined in accordance with the characteristics of the protections adopted.
-  The protection devices of the unit power line must be able to stop the presumed short circuit current, whose value must be determined in function of system features.
-  Refer to the unit electrical diagram (the number of the diagram is shown on the serial number label).
-  verify that the network has characteristics conforming to the data shown on the serial number label.
-  Before starting work, verify that the sectioning device at the start of the unit power line is open, blocked and equipped with cartel warning.
-  The supply line must be disconnectable from the rest of the building's power mains with an all-pole magnetothermic circuit breaker with separation of contacts on all poles, to be implemented in accordance with current laws and regulations.
-  The protection must be sized in accordance with the electrical data declared by the manufacturer.
-  Disconnect the power supply before making any connection.
-  Do not crush cable bundles and prevent them from coming into contact with piping and any sharp edges.
-  Primarily you have to realize the earthing connection.
-  Incorrect grounding may cause electric shocks.
-  All external high voltage loads, if connected to a metal fitting or grounding clip, must be earthed.
-  The current required for each external load must be less than 0.2 A. If the current required for a single load is greater than 0.2 A, insert a contactor for control.
-  Install an earth leakage breaker (30 mA).
-  Failure to observe this precaution may result in electric shocks.
-  Power and signal cables should be routed as separately as possible to avoid any interference.
-  Keep the unit's controller wiring as far away from hot surfaces as possible. It is advisable to use cables with cross-linked polyvinyl chloride sheath.
-  For the electrical connection, use a cable of sufficient length to cover the entire distance without any connection work. Do not use extension cords. Do not apply other loads on the power supply.
-  If the power cable is damaged, it must be replaced by qualified personnel and in accordance with current national regulations.
-  The manufacturer is not liable for any damage caused by failure to install a grounding system or failure to comply with the diagrams.
-  Check the voltage values which must be within the limits: 220-240V +/- 10% and 380-415V +/- 6%.
-  Before power the unit, make sure that all the protections that were removed during the electrical connection work have been restored.
-  It is forbidden to connect the earth wire to gas or water pipes, lightning rods or telephone ground.

9.2 General diagram

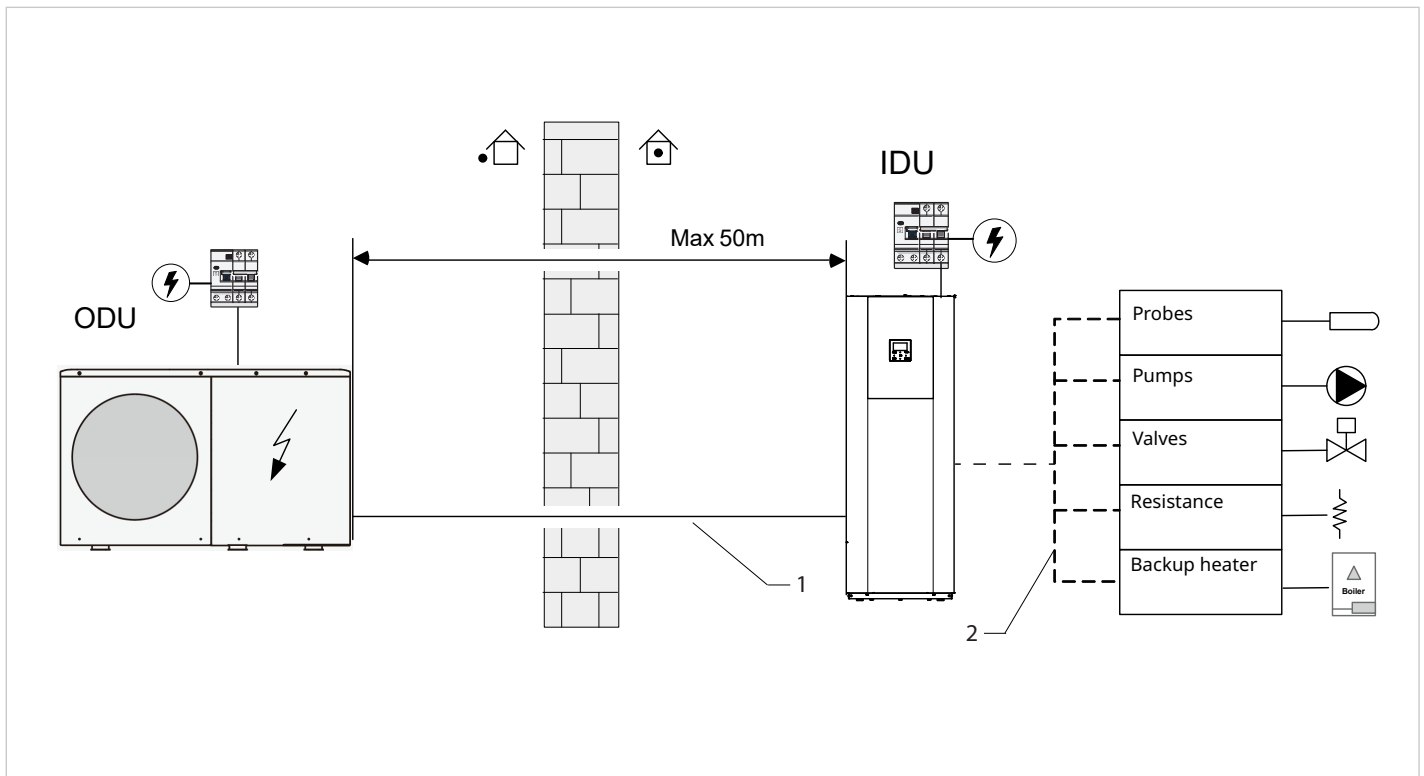

- 1 Bus connection
- 2 Connections to be provided by customer

9.3 Cable inlet

To access the panel, see the "Access to internal parts" section.

- ⚠ Before removing the protection panel from the electrical panel, disconnect the power supply to the indoor and outdoor units and to all the other electrically powered components.

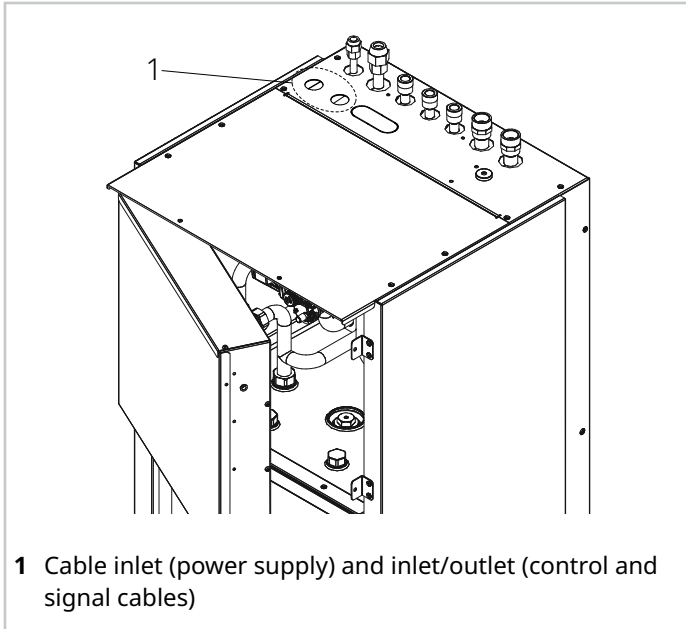

Cable entry in the electrical panel

The connection cables are plugged into the back of the electrical panel.

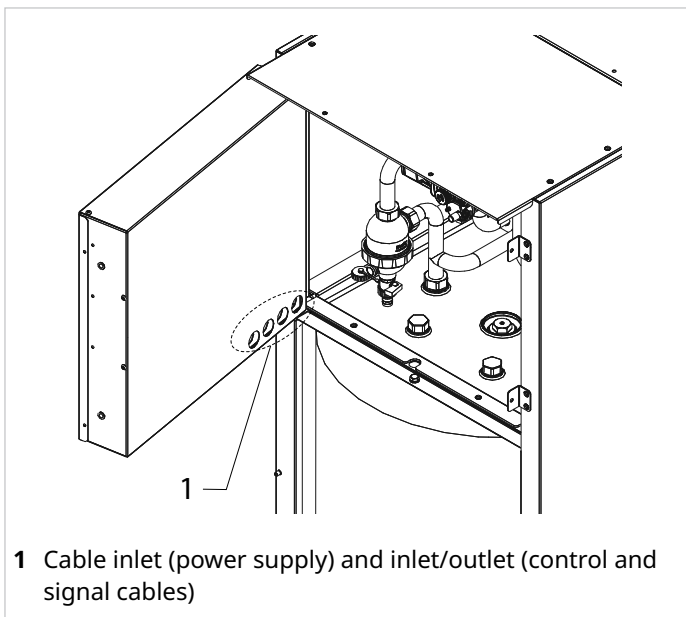

- ⚠ Connect as shown in the wiring diagrams.

9.4 Connecting the power supply

- ⚠ Ensure that:

- no cables of different cross-sections are connected to the same power supply terminal block (loosening of the power supply wires could cause overheating)
- terminal block screws are not over-tightened
- an earth leakage breaker and a fuse or magnetothermic circuit breaker are connected to the supply line
- leave the power supply cable long enough for the electrical panel to be opened.

9.4.1 Single-phase units

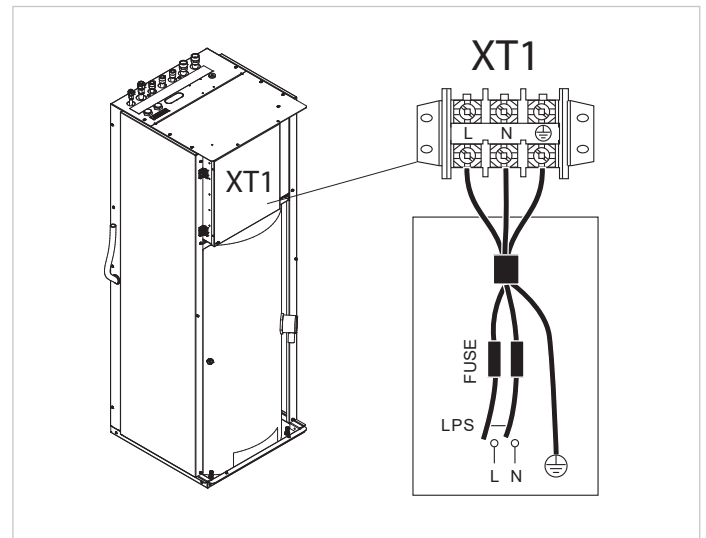

9.4.2 Three-phase units

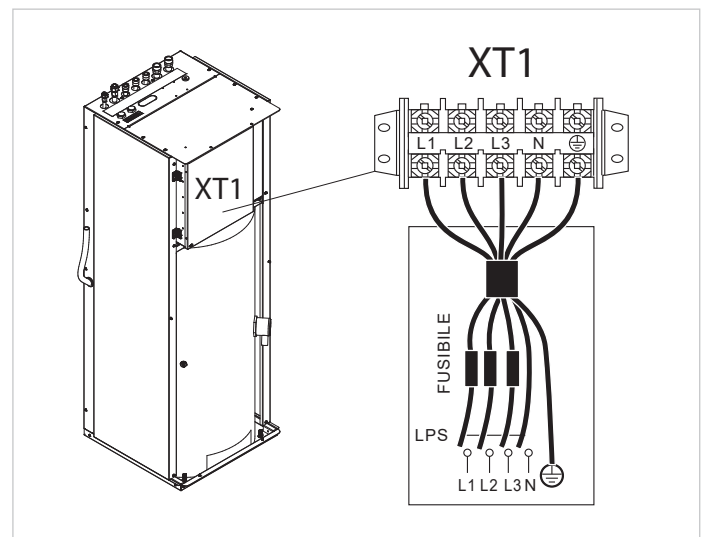

- ⓘ Only with 6 or 9 kW additional electric heater option.

9.4.3 Electric cable sizes

Standard Units

Unit	1ph
	190 L - 250 L
Maximum overcurrent protection (MOP)	16 A
FLA	9,5 A
Cable cross-section (mm ²)	2,5

Units with IBH

Unit	1ph	3ph
	190 L - 250 L	190 L - 250 L
Maximum overcurrent protection (MOP)	25 A	16 A
FLA	18 A	14 A
Cable cross-section (mm ²)	4	2,5

Tightening torques

	Tightening torque (N•m)
M4 (power terminal, electric control board terminal)	from 1.2 to 1.4
M4 (earthed)	from 1.2 to 1.4

i For the sizing values of the external protections, refer to the rated electrical data (bulletin, labels).

Connection procedure:

- ▶ connect the cables to the appropriate terminals as shown in the diagram
- ▶ secure the cables with cable clamps.

9.5 External component connections

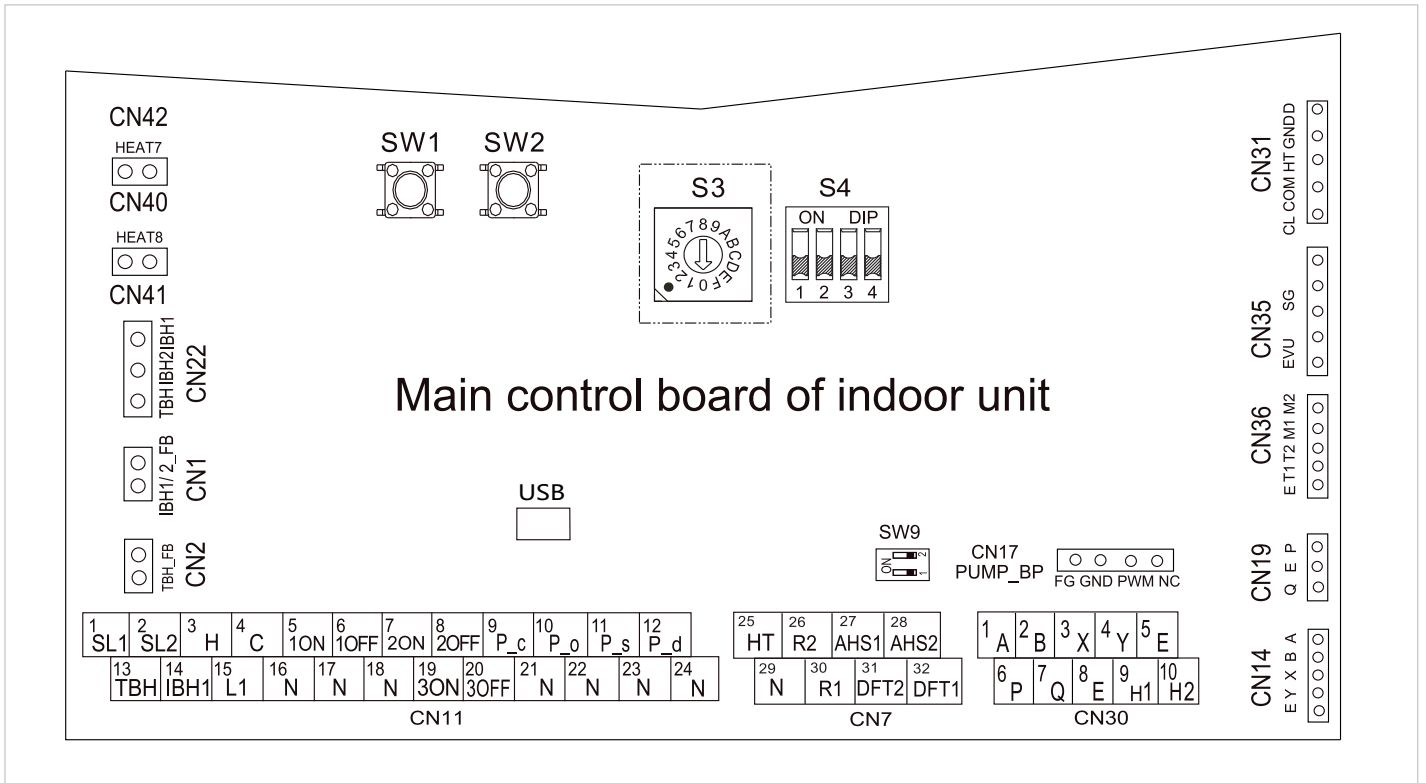

Ref.	Terminal block CN11			
1	1	SL1	Solar input	Dry contact
	2	SL2		
2	3	H	Room thermostat (220V)	Dry contact
	4	C		
	15	L1		
3	5	1ON	SV1 DHW 3-way valve	Dry contact
	6	1OFF		
	16	N		
4	7	2ON	SV2 2-way zone valve	Dry contact
	8	2OFF		
	17	N		
5	9	P_c	pump P_c (zone2)	Dry contact
	21	N		
6	10	P_o	Pump P_o (zone1)	Dry contact
	22	N		
7	11	P_s	Solar pump	Dry contact
	23	N		
8	12	P_d	DHW recirculation pump	Dry contact
	24	N		
9	13	TBH	TBH heater	Dry contact
	16	N		
10	14	IBH1	External backup heater	Dry contact
	17	N		

Ref.	Terminal block CN11			
11	18	N	SV3 Zone 2 3-way mixing valve	Dry contact
	19	ON		
	20	OFF		
Ref.	Terminal block CN7			
1	26	R2	Unit in operation signal	Dry contact
	30	R1		
	31	DFT2		
2	32	DFT1	Defrosting status or alarm status	Dry contact
	25	HT		
	29	N		
	27	AHS1	Additional boiler	Dry contact
	28	AHS2		
Ref.	Terminal block CN30			
1	1	A	Wired controller	Dry contact
	2	B		
	3	X		
	4	Y		
	5	E		
2	6	P	Reserved	Dry contact
	7	Q		
3	9	H1	M/S connection for units in cascade	Dry contact
	10	H2		

Refrigerant connections

i External electrical components KM..., Fuses, etc. are to be provided by the customer.

9.5.1 Bus connection

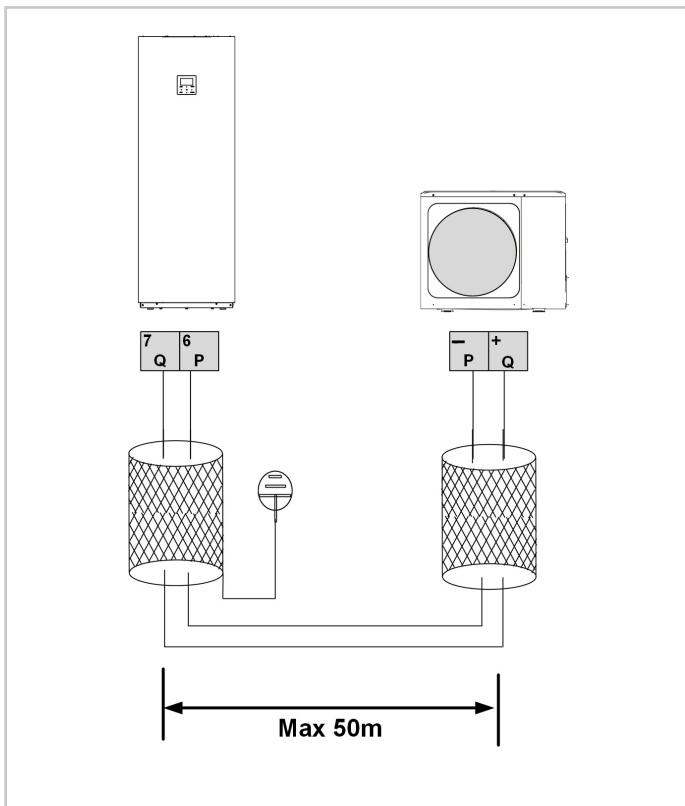

Cable type

2-core shielded cable 0.75 - 1.25 mm² (AWG18-AWG16)

9.5.2 1-zone system

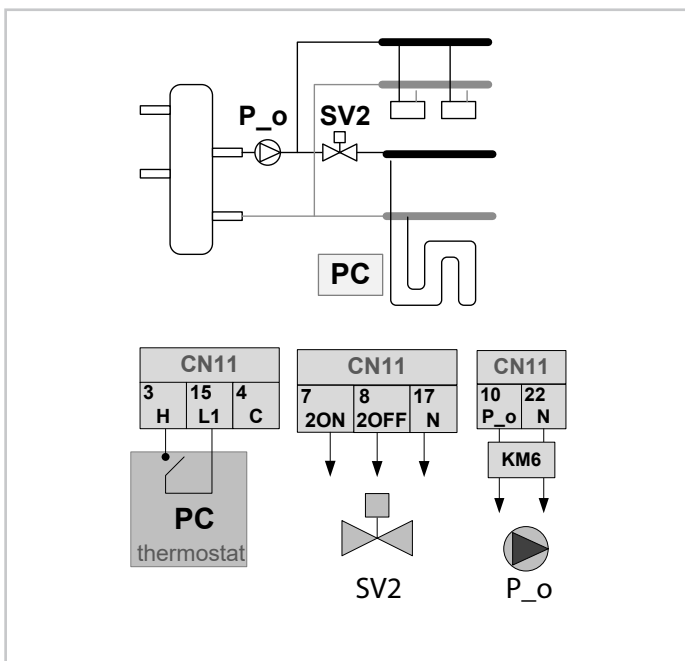

9.5.3 Double zone mixed system

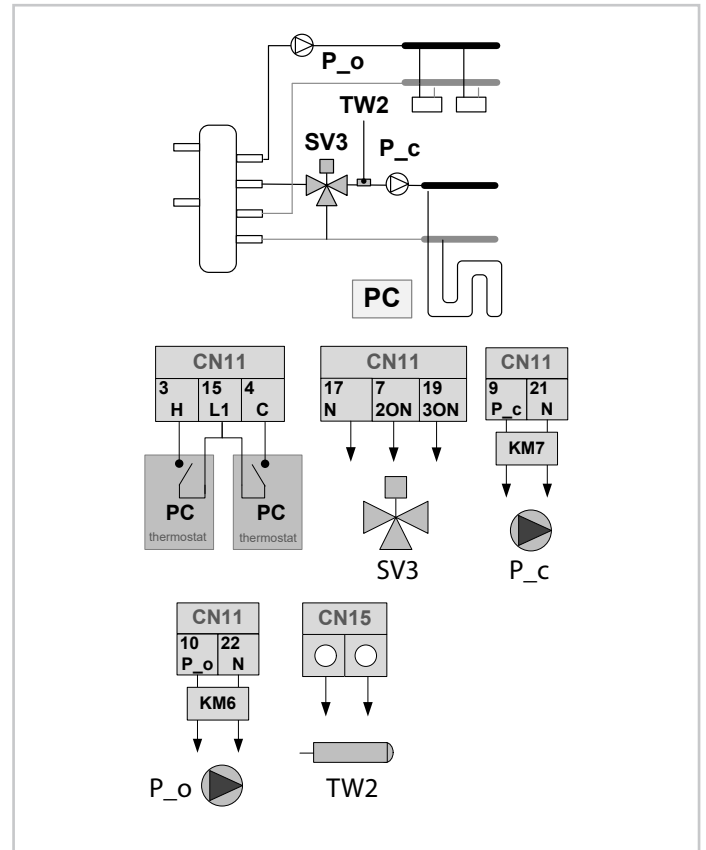

9.5.4 DHW recirculation pump

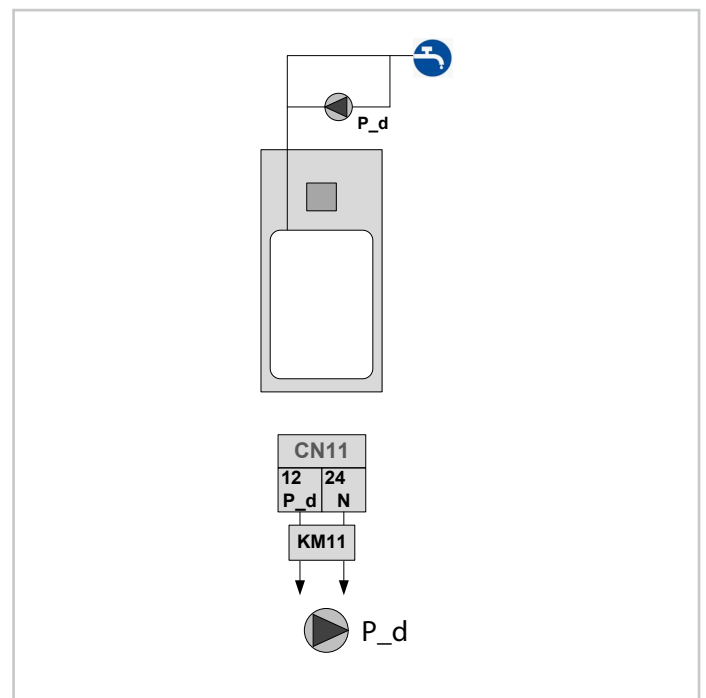

Contact type	220-240 VAC
Maximum tripping of protections (A)	0.2
Cable cross-section (mm ²)	0.75

9.5.5 Solar pump

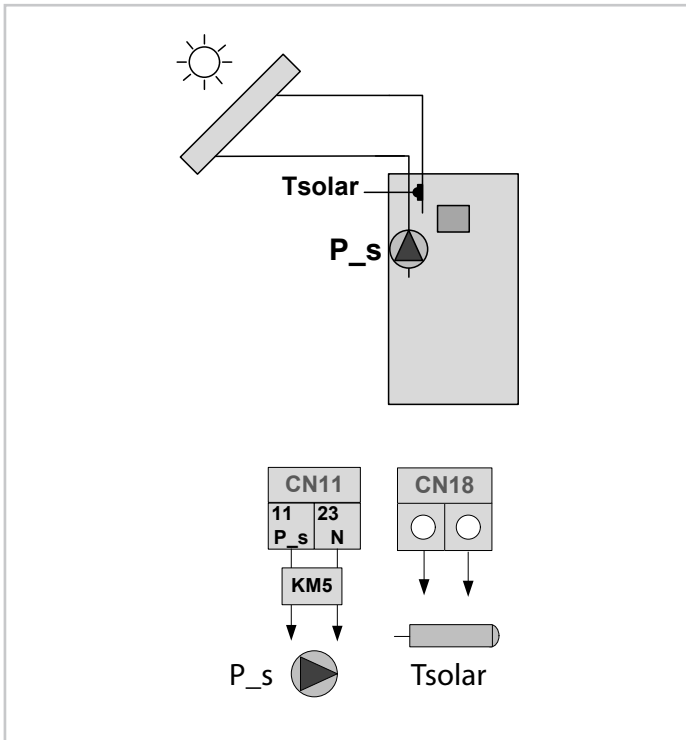

9.5.6 Antifreeze heater for piping

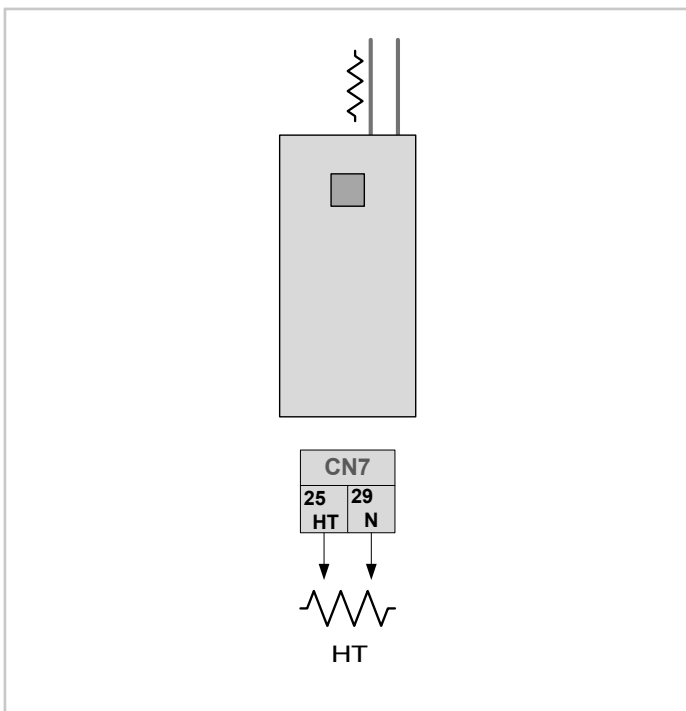

9.5.7 Integration heating elements

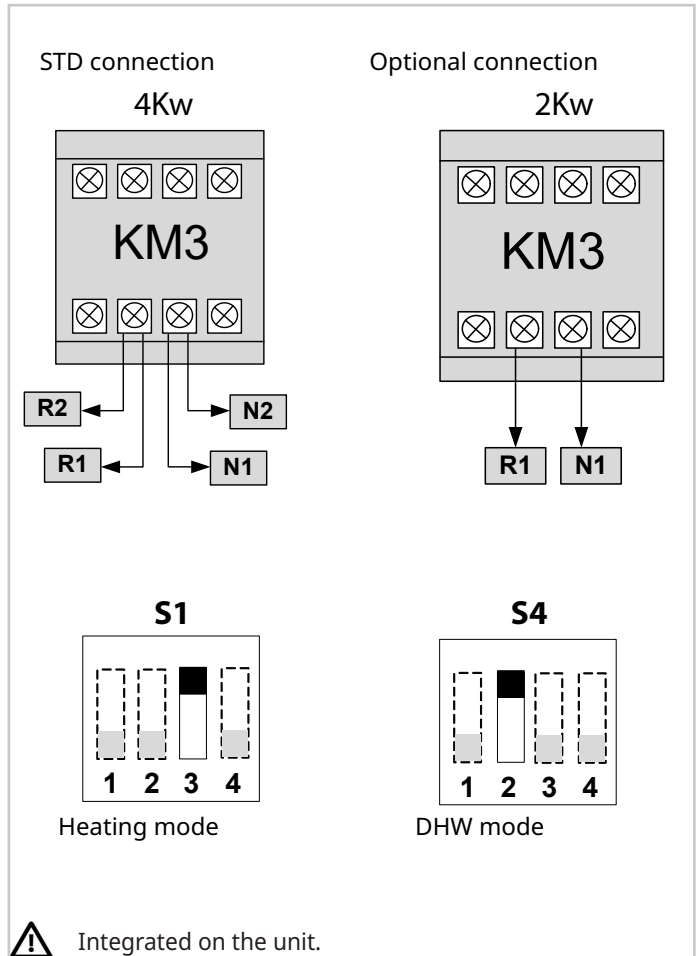

9.5.8 Defrosting status or alarm status

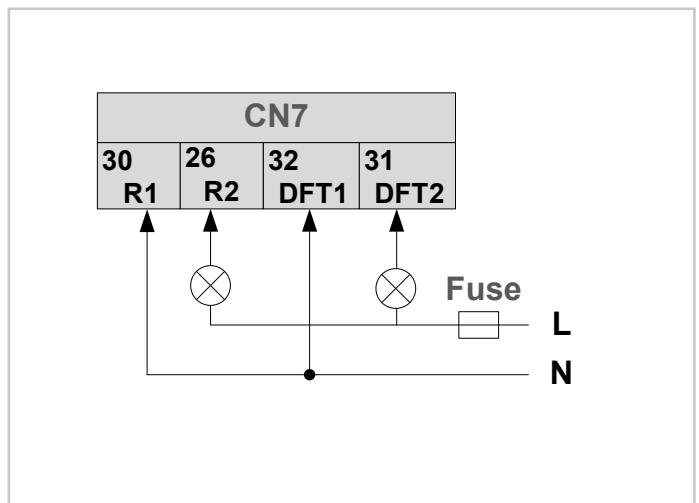

Contact type	220-240 VAC
Maximum tripping of protections (A)	0.2
Cable cross-section (mm ²)	0.75

9.5.9 Backup heater (UC boiler)

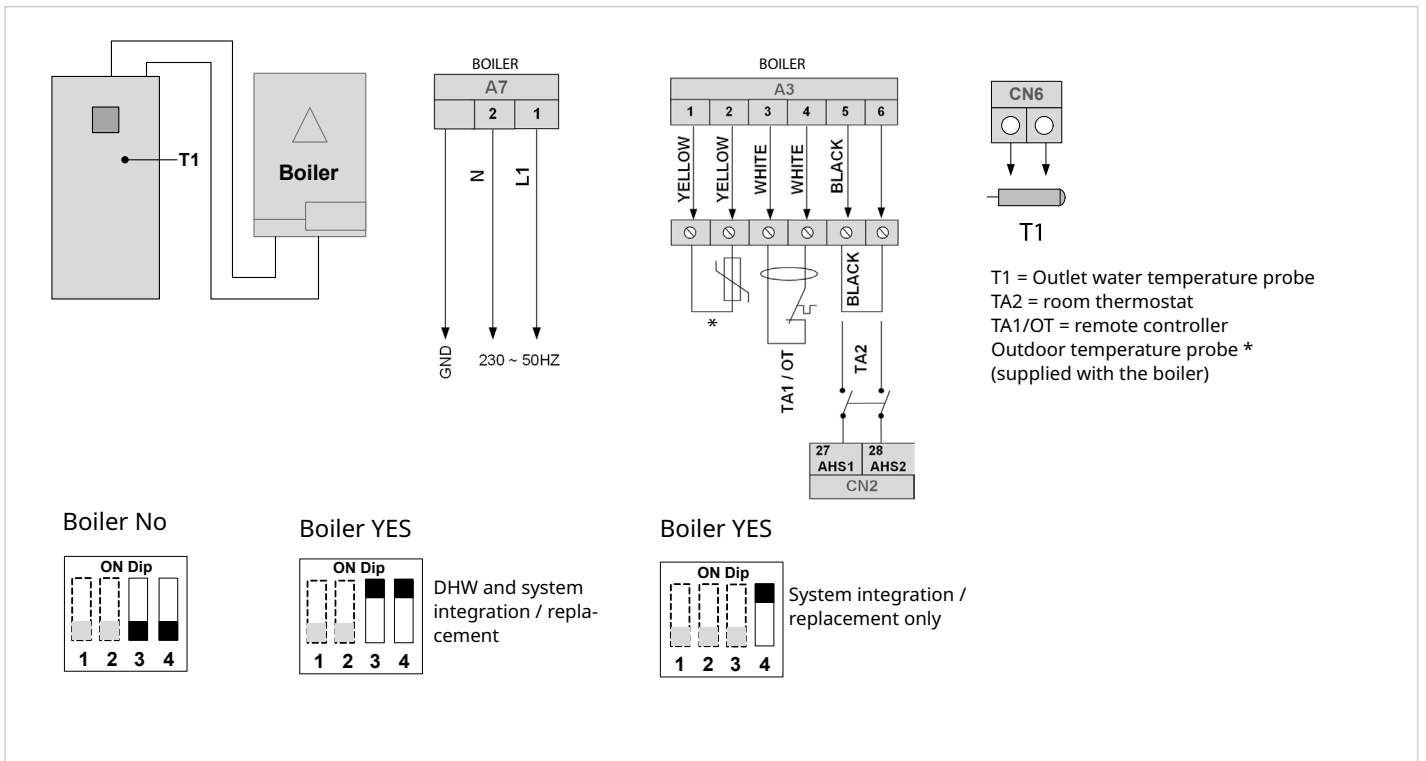

9.5.10 Backup heater (FE boiler)

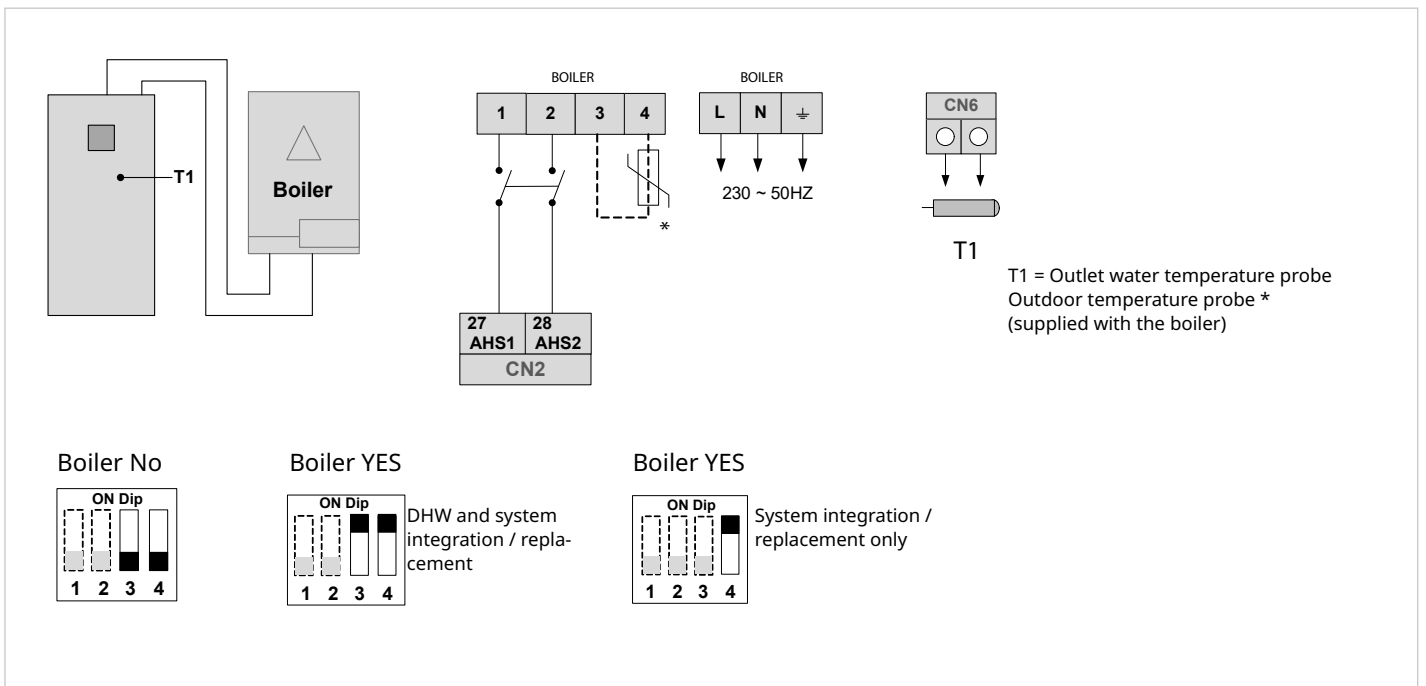

Contact type	220-240 VAC
Maximum tripping of protections (A)	0.2
Cable cross-section (mm ²)	0.75

9.6 Zone thermostat

The zone thermostat (to be supplied separately: use the Manufacturer's accessory or equivalent) can be connected in three different ways. The choice of which one to use depends on the type of application.

i For the parameter settings, see the installer keypad interface manual (menu - 6 Room thermostat setting)

Method A

One zone system with zone thermostat managing the unit's ON/OFF and mode change.

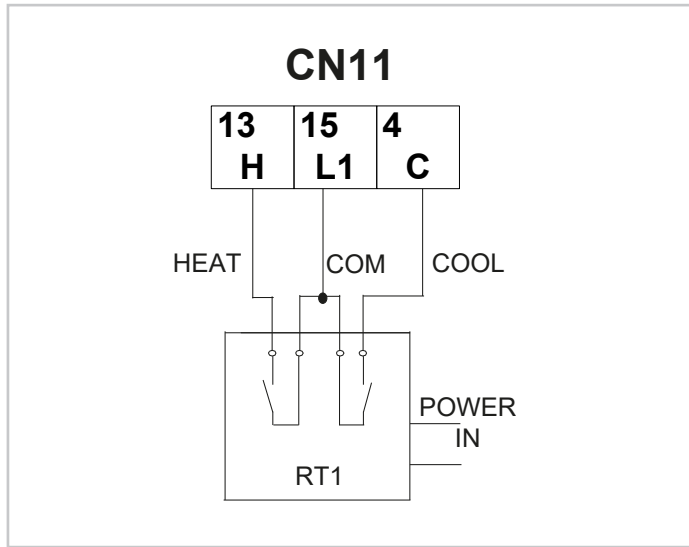

Method B

One zone system with zone thermostat managing only ON/OFF, user interface managing the unit's mode change.

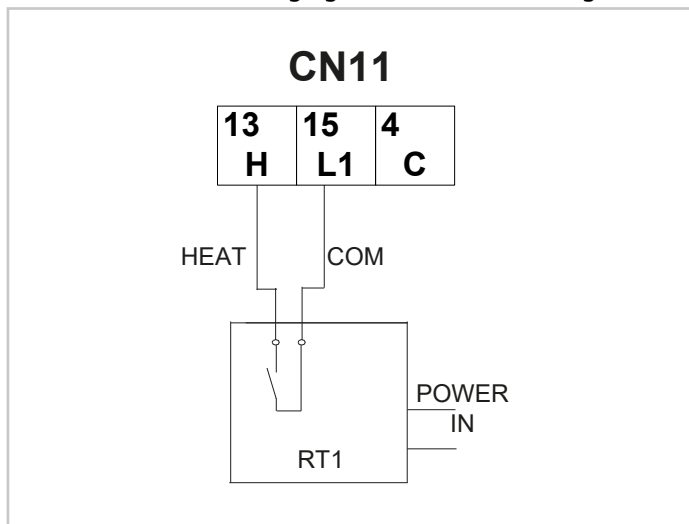

i In the presence of a zone thermostat, the HMI must be used to control the water supply temperature. It is not possible to select air temperature control using the HMI air probe.

Method B

Double zone system with two zone thermostats managing

ON/OFF, user interface managing the unit's mode change.

The indoor unit is connected with two room temperature thermostats.

- Zone 1 On-Off from input H - L1
- Zone 2 On-Off from input C - L1
- Heat-Cool from user interface

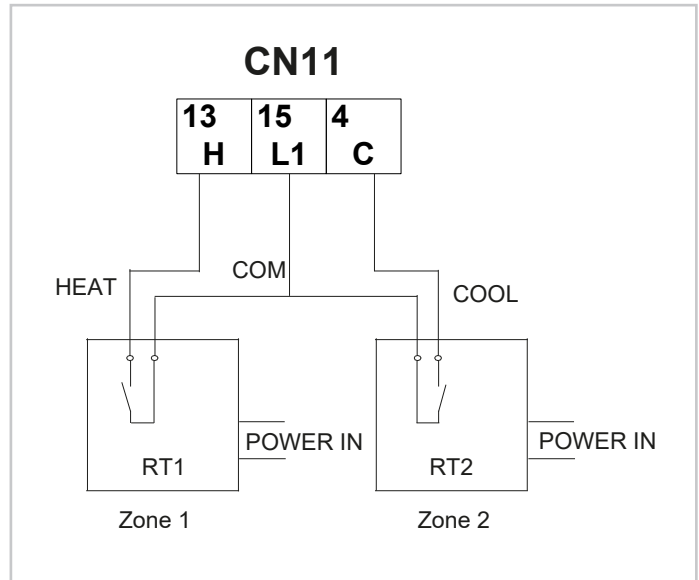

i The electrical connection of the thermostat should match the user interface settings. The power supply of the unit and that of the room thermostat must be connected to the same neutral line and to the phase line (L2) N (three-phase units only).

9.7 SMART GRID - Photovoltaic management

The smart grid system allows the excess electricity produced by the photovoltaic system or the electricity distribution network to be used to accumulate domestic hot water at lower or no cost.

The function can be used with enabled electricity distribution networks.

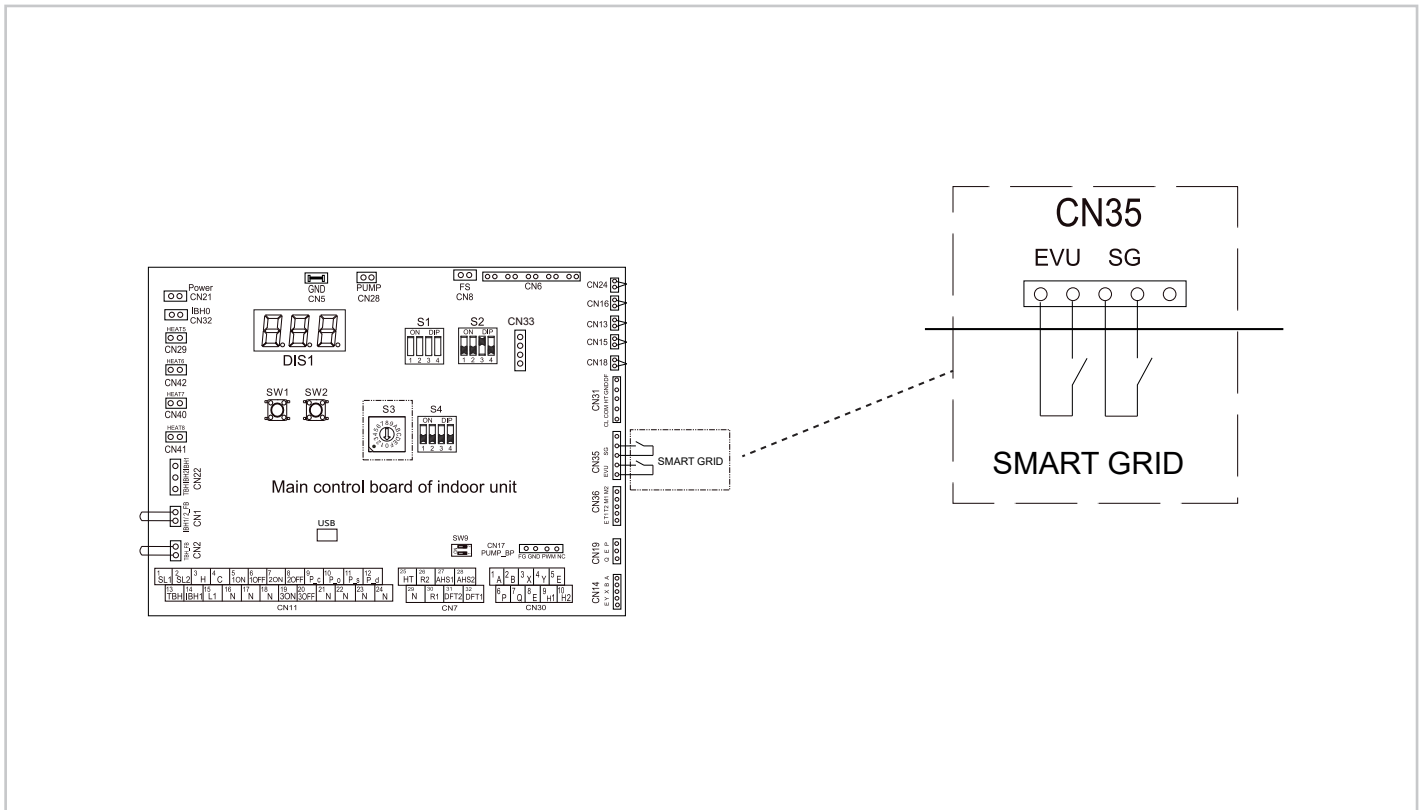

Energy cost	Contact		Available heaters	Operation	
	SG	EVU		System	DHW
Free	ON	ON	-	Standard	No request for Heating / Cooling: forced operation in DHW mode with set point T5S = 60°C
			IBH		Forced domestic hot water operation with T5S set point = 70°C. TBH is forcibly started until the domestic hot water set point is reached. If necessary, the Heat Pump can work simultaneously on the Heating/Cooling system.
			TBH		
			IBH + TBH*		
Economical	OFF	ON	-	Standard	The domestic hot water set point is forced to T5S + 3°C
			IBH		The domestic hot water set point is forced to T5S + 3°C The TBH is forced to start when T5 < T5S - 2°C and stops when T5 ≥ T5s + 3°C
			TBH		
			IBH + TBH*		
Standard	OFF	OFF	qualsiasi	Standard	Standard
Expensive	ON	OFF	-	Forced OFF	Forced OFF**
			IBH / TBH		

*If IBH and TBH are enabled together, IBH can only be used for system heating.

**DISINFECT, FAST DHW, TANK WATER and other DHW-related functions are disabled.

Frost protection and defrosting operate smoothly in all conditions.

If AHS is available, it can operate normally in Heating or DHW mode in all conditions.

9.8 Control4 NGR

Option

 For details, see Control4 NRG instruction manual.

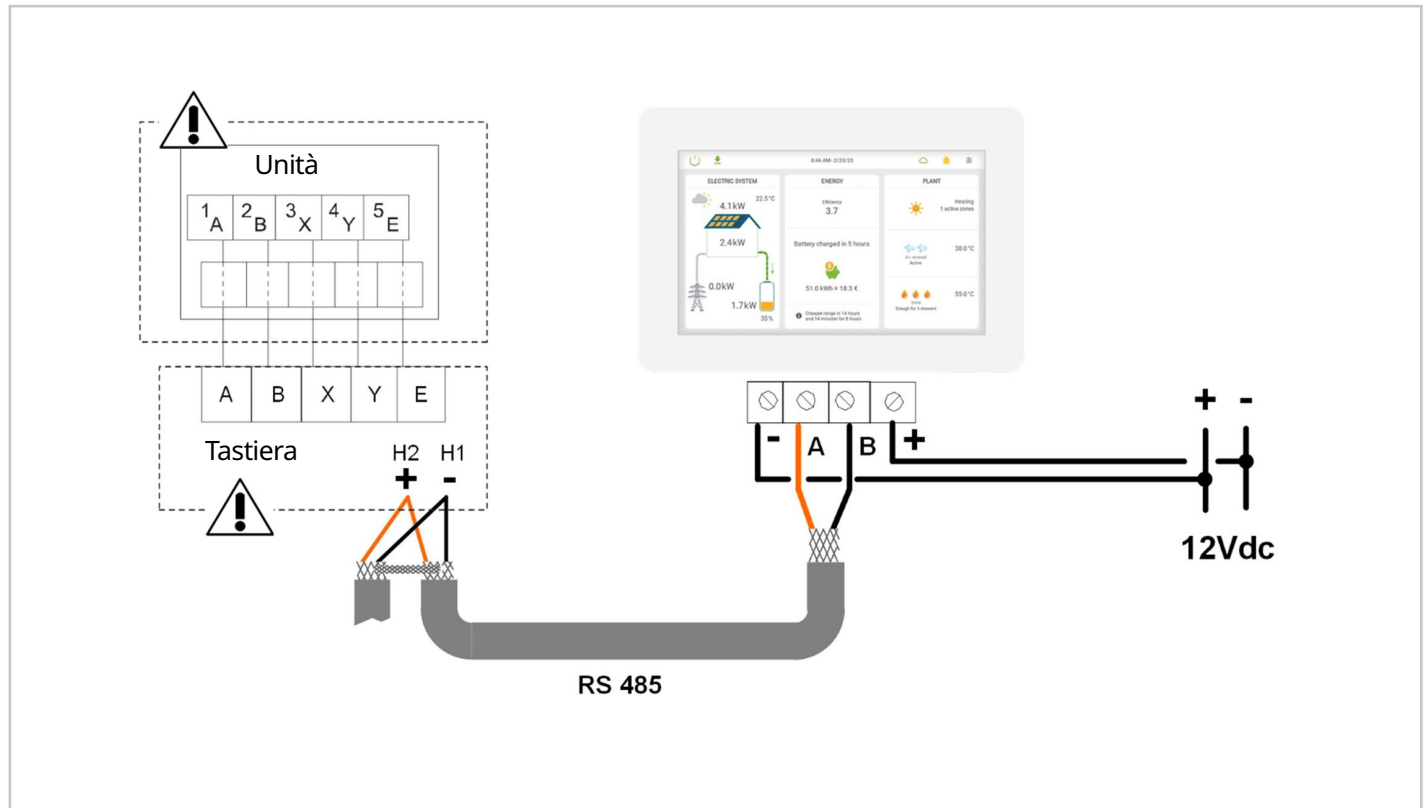

Settings

FOR SERVICEMAN > 17 HMI ADDRESS SET > 17.2 HMI ADDRESS FOR BMS = 2.

Modbus connection







Baud rate = 9600

Length = 8

Parity = none

Stop bit = 1

10. Starting up the system

-  This section is intended only for the Technical Support Service.
-  The electrical and hydraulic connections and other works typical of the system are the responsibility of the Installer.
-  Operate in compliance with safety regulations in force.
-  Upon request, the service centres performing the start-up.
-  Agree upon in advance the start-up data with the service centre.
-  When installing or servicing, never leave the unit unattended after removing the service panels.
-  **Check that:**
 - the unit should be installed properly and in conformity with this manual
 - the electrical power supply line should be isolated at the beginning
 - the unit isolator is open, locked and equipped with the suitable warning
 - the unit is not powered.

Remember that:

- during installation, unit settings and parameters should be configured by the Installer according to the installation configuration, climatic conditions, and end-user preferences
 - the relevant settings are accessible and programmable through the user interface.
-  Refer to the user interface manual for operation.

10.1 Preliminary checks

 For details refer to the different manual sections.

10.1.10.1 Unit power supply: OFF

1	Clearances: <ul style="list-style-type: none"> • check that distances are observed
2	Refrigerant piping characteristics: <ul style="list-style-type: none"> • check that the refrigerant piping section is correct • check that the fitting provided are used • check that the equivalent piping length exceeds 3 or ≤ 30 m • check that the level difference is less than 25 m
3	Unit emptying and charging: <ul style="list-style-type: none"> • check that the unit is emptied correctly • check whether additional refrigerant charge is required • visually check that there are no oil leaks
4	Water characteristics: <ul style="list-style-type: none"> • check that the permissible water values are complied with
5	Water filter: <ul style="list-style-type: none"> • check that it is correctly installed at the entrance to the aqueduct
6	System water filter: <ul style="list-style-type: none"> • check that it is correctly installed on the system supply
7	Water line input: <ul style="list-style-type: none"> • check the correct connection of the water outlet and water inlet
8	Non-return valve: <ul style="list-style-type: none"> • check that there is a non return valve on the DHW circulation
9	DHW pressure relief valve: <ul style="list-style-type: none"> • check that the valve is present
10	DHW expansion vessel: <ul style="list-style-type: none"> • check that the expansion tank is present
11	Compressor support bracket: <ul style="list-style-type: none"> • check that it has been removed
12	Anti-vibration mounts on hydraulic connections: <ul style="list-style-type: none"> • check their presence
13	System: <ul style="list-style-type: none"> • check that it is charged • check the system pressure • check that it has been vented
14	On-site wiring: <ul style="list-style-type: none"> • check that all wiring connections comply with the instructions in this manual











15	<p>Fuses, circuit breakers or protection devices:</p> <ul style="list-style-type: none"> • check that the size and type comply with the instructions in this manual • ensure that no fuses or protective devices have been bypassed
16	<p>Automatic switch of integrative electric heater:</p> <ul style="list-style-type: none"> • check that the circuit breaker of the additional electric heater in the electrical panel is closed (varies depending on the type of additional electric heater). Refer to the wiring diagram
17	<p>Automatic switch of supplementary electric heater for DHW cylinder:</p> <ul style="list-style-type: none"> • check the circuit breaker of the supplementary electric resistance for DHW tank is closed (applicable only to units with optional domestic hot water tank)
18	<p>Internal wiring:</p> <ul style="list-style-type: none"> • check that the wiring and connections inside the electrical cabinet are tight and in good condition • check that the grounding wiring is perfectly tightened and in good condition
19	<p>Assembly:</p> <ul style="list-style-type: none"> • check that hydraulic connections are properly tightened to avoid water leaks, abnormal noises and vibrations when starting the unit
20	<p>Damaged components:</p> <ul style="list-style-type: none"> • check the components and circuitry inside the unit for damage or deformation
21	<p>Power supply voltage:</p> <ul style="list-style-type: none"> • check that the power supply voltage is within the values indicated on the unit's serial number label
22	<p>Shut-off valve:</p> <ul style="list-style-type: none"> • check that all shut-off valves are open
23	<p>Structure:</p> <ul style="list-style-type: none"> • check all the structure of the unit is mounted correctly
24	<p>Outdoor unit condensate:</p> <ul style="list-style-type: none"> • check that it is disposed of correctly • check that it does not freeze in winter

10.2 SYSTEM CONFIGURATION

 For system configuration, of advanced features, refer to the user interface manual.

11. Start-up

Preliminary warnings

-  For system configuration, of advanced features, refer to the user interface manual.
-  When the unit is turned on, nothing is displayed on the user interface.
-  Check the following anomalies before diagnosing possible error codes:
 - electrical connection problem (power supply or communication signal)
 - fuse failure on main electronic board
-  Error code "E8" or "E0" is displayed on the user interface:
 - there is air in the system
 - water pressure in the system is insufficient
 - the water flow rate in the system is insufficient
-  Before starting the test run, make sure that the water system and the storage tank are full of water and that the air has been vented. Otherwise the system components could suffer irreversible damage.
-  Error code "E2" is displayed on the user interface:
 - check the wiring between the user interface and the unit.
-  Initial start-up at low outside temperature:
 - for the initial start-up when the outside temperature is low, the water should be heated gradually
 - use the underfloor preheating function
-  Refer to the user interface manual for operation.
-  For radiant panel systems.
-  If the temperature rises abruptly in a short time, the floor could suffer irreversible damage.

During start-up, the following checks must be carried out:

- 1 Air vent
- 2 Test of operating modes

11.1 Compressor casing heater

External unit

Power the outdoor unit for at least 8 hours before starting the compressor:

- upon unit commissioning
- after every prolonged stop period with unit not powered
- power the heaters: disconnect switch on 1 / ON
- check the electric consumption of the heaters to make sure they are working
- only start up if the compressor crankcase temperature on the lower side is at least 10°C higher than the outdoor

temperature

-  Do not start the compressor with carter oil not in temperatureTensioni

11.2 Opening the "For serviceman" menu

To access:

- ▶ press **Menu**
- ▶ select for serviceman
- ▶ press **OK**
- ▶ Enter PWD
- ▶ press **OK**

-  To find out the password, refer to the service manual or contact the manufacturer.

After modifications:

- ▶ press **BACK**
 - the confirmation page is displayed
- ▶ select **YES**
- ▶ press **OK**

11.3 Air vent

Activates the vent cycle that removes air in the hydraulic circuit that can cause unit malfunction.

To activate the vent cycle:

- ▶ access the "For serviceman" menu
- ▶ Select "Test run"
 - the confirmation page is displayed
- ▶ select **YES**
- ▶ press **OK**
- ▶ select "Air vent"
- ▶ press **OK**

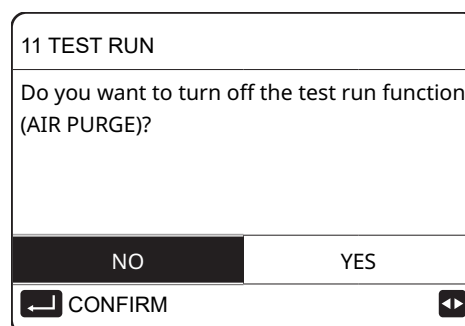

11.4 Test of operating modes

Verify the correct operation of:

- circulation pump
- cooling mode
- heating mode
- DHW mode

To verify:

- ▶ access the "For serviceman" menu
- ▶ Select "Test run"
- ▶ press OK
- the confirmation page is displayed
- ▶ select **YES**
- ▶ press **OK**
- ▶ select the operation mode
- ▶ press OK
- ▶ the test starts

11.5 Start-up report

Identifying the operating objective conditions is useful to control the unit over time.

With the unit at steady state, i.e. in stable and close to working conditions, collect the following data:

- total voltages and absorptions with unit at full load
- absorptions of the different electric loads (compressors, fans, pumps etc)
- temperatures and flows of the different fluids (water, air) both in input and in output from the unit
- temperature and pressures on the characteristic points of the refrigerating circuit (compressor discharge, liquid, intake)

The measurements must be kept and made available during maintenance interventions.

11.6 2014/68/UE PED directive

DIRECTIVE 2014/68/UE PED gives instructions for installers, users and maintenance technicians as well.

Refer to local implementing regulations; briefly and for information only.

Compulsory verification of the first installation:

- only for units assembled on the installer's building site (for ex. Condensing circuit + direct expansion unit)
- Certification of setting in service:
- for all the units

Periodical verifications:

- to be executed with the frequency indicated by the Manufacturer (see the "maintenance inspections" paragraph)

12. Maintenance

12.1 Prerequisites

 This section is intended only for the Technical Support Service.

 All operations must be carried out by personnel who meet the requirements of current regulations and are trained in the risks related to such operations.

 Operate in compliance with safety regulations in force.

The maintenance allows to:

- maintaining the unit efficient
- reduce the deterioration speed all the equipment is subject to over time
- assemble information and data to understand the unit's efficiency status and prevent possible failures.

Check that:

- the electrical power supply line should be isolated at the beginning
- the unit isolator is open, locked and equipped with the suitable warning
- the unit is not powered.

 After turning off the power, wait at least 5 minutes before accessing to the electrical panel or any other electrical component.

 Before accessing check with a multimeter that there are no residual stresses.

 When installing or servicing, never leave the unit unattended after removing the service panels.

12.2 Maintenance check list

Intervention frequency (months)		1	6	12
1	panel fixing			X
2	outdoor unit fan fixing		X	
3	outdoor unit coil cleaning		X	
4	hydraulic system filling pressure		X	
5	fittings, caps and wells tightening		X	
6	visual leak check on solar panel fittings		X	
7	air in the piping			X
8	flow switch / differential pressure switch operation			X
9	drain dirt separator	X	X	X
10	anode check		X	
11	power remote controls status			X
12	clamp closure, cable isolation integrity			X
13	voltage and phase unbalancing (no load and on-load)		X	
14	absorptions of the single electrical loads		X	
15	compressor crankcase heaters test		X	
16	leak control *			X
17	cooling circuit work parameter detection		X	
18	drier filter check			X
19	presence of oil stains		X	
20	closure of pipe unions, Schrader plugs		X	
21	protection device test: pressure relief valves, pressure switches, thermostats, flow switches, etc.		X	
22	check schedulers, setpoints, compensations, etc.		X	
23	control device test: alarm warnings, thermometers, probes, pressure gauges, etc.		X	
24	fill in the unit's booklet			

i *Refer to the local regulations. Companies and technicians that carry out installation, maintenance/fixing, leak control and recovery interventions must be CERTIFIED as required by local regulations.

12.3 Unit booklet

It's advisable to create a unit booklet to take notes of the unit interventions.

In this way it will be easier to adequately note the various interventions and aid any troubleshooting.

Report on the booklet:

- date
- intervention description
- carried out measures etc.

12.4 Standby mode

In case of a long period of inactivity:

- ▶ turn off the power
- ▶ turn off all disconnecter switches connected to the unit
- ▶ avoid the risk of frost (use glycol or empty the system)

12.5 Emptying the system

The units are not fitted with a drain valve, so one must be provided on a pipe connecting to the system near to the device and below it.

 All operations must be carried out with the unit shut down and disconnected from the mains power supply.

Before emptying:

- ▶ check that the system water filling/refilling valve is closed

To drain the system:

- ▶ open the drain valve on the outside of the device
- ▶ open all of the system and terminal relief valves

12.6 Cleaning the outer coating

To clean:

- ▶ soapy water
- ▶ water-based detergents containing anionic and/or non-ionic surfactants

Always rinse with clean water.

 Do not use solvent-based degreasing agents such as: acetone, denatured ethyl alcohol, trichloroethylene, white spirit, etc.

 Do not use dilute acids in aqueous solution (Hydrochloric Acid, Nitric Acid) and products containing dilute acids.

 Do not use dilute bases in aqueous solution (Caustic Soda, Sodium Hypochlorite, Ammonia).

 Do not use fluorinated hydrocarbons.

 Do not use mineral-based lubricating oils.

 These substances can attack the surface of the product and lead to the formation of cracks and, over time, to the possibility of breakage of the plastic material.

12.7 Structure

 Check the condition of the parts making up the structure.

 Paint so as to eliminate or reduce oxidation at the points in the unit where this problem may occur

 Check the fastening of the external paneling of the unit. Poor fastening may give rise to malfunctions and abnormal noise and vibration,

12.8 Water pressure

- ▶ check that the water pressure is greater than 1 bar

If necessary:

- ▶ add water up to 1.5-1.8 bar

12.9 Water filter

- ▶ check and clean the water filter

In case of obstruction:

- ▶ clean the filter

12.10 Expansion vessel

- ▶ check the expansion vessel charge
- ▶ check at least once a year

If you necessary load with nitrogen, take care that the pressure does not exceed the value indicated on the label.

12.11 Unit electrical panel

- ▶ visually inspect the electrical panel
- ▶ check the tightness of the connections
- ▶ check the cleanliness of the electrical panel

12.12 Using glycol

least once a year

- ▶ check the glycol concentration and pH value of the system

A pH value below 8.0:

- ▶ indicates that a significant proportion of the inhibitor has been consumed
- ▶ topping up

A pH value of less than 7.0:

- ▶ indicates that the glycol has oxidised
- ▶ drain and flush the system thoroughly to prevent serious

damage

- ⚠ The glycol solution must be disposed of in accordance with the local laws and regulations in force.

12.13 Magnetic sludge

Magnetic filter separates the impurities (sand particles, rust ... etc) present in the system water. The impurities are collected in a settling chamber. Cleaning the filter can also be done with a working system.

Clean the filter:

- during the start up of the unit
- after one week from the start up
- after one month from start up
- once a year

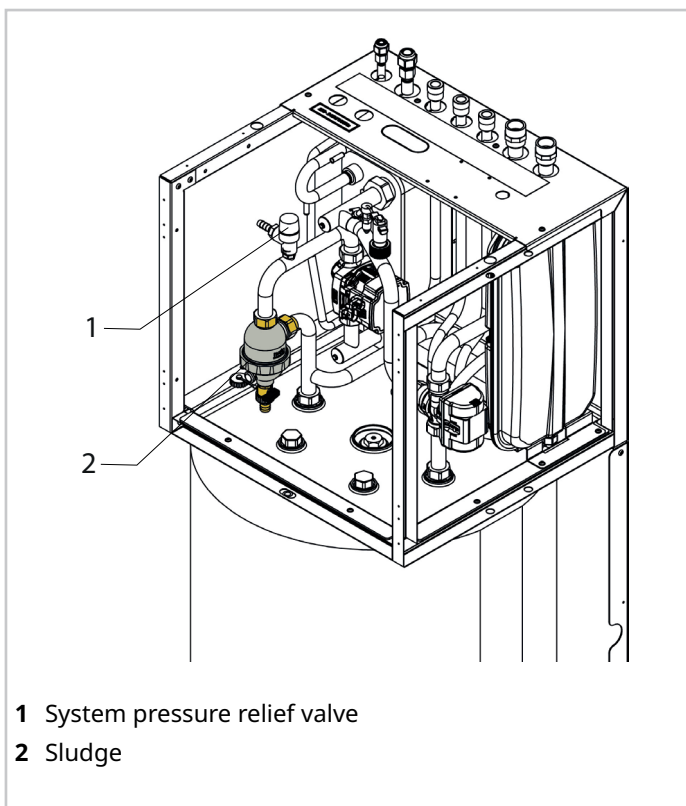

- ⚠ Open the pressure relief valve to discharge the system pressure.

Clean the filter:

- ▶ remove the magnet holder cartridge
- ▶ open the tap to purge impurities
- ▶ close the tap

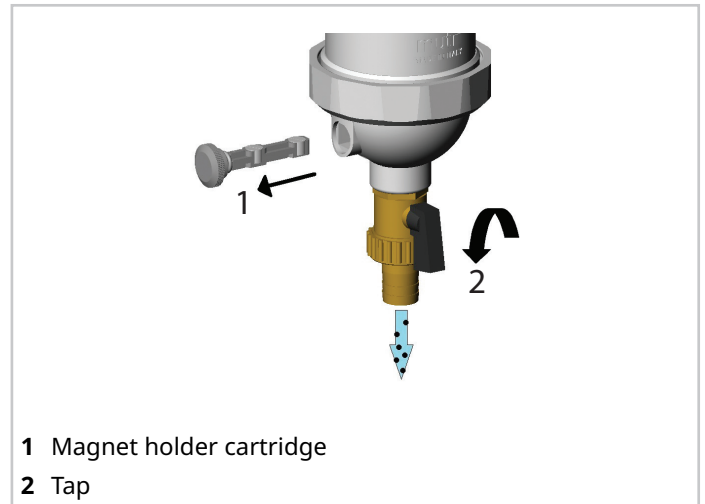

Cleaning (extraordinary)

Close the shut-off valves of the system and water supply.

Disassembly sequence:

- ▶ unscrew the ring nut of the lower cover of the dirt separator
- ▶ remove the filter
- ▶ take out the magnet cartridge
- ▶ clean the filter
- ▶ clean the filter and the bottom cover
- ▶ reinsert the magnet cartridge
- ▶ close the bottom cover of the dirt separator
- ▶ open the shut-off valves of the plant and aqueduct

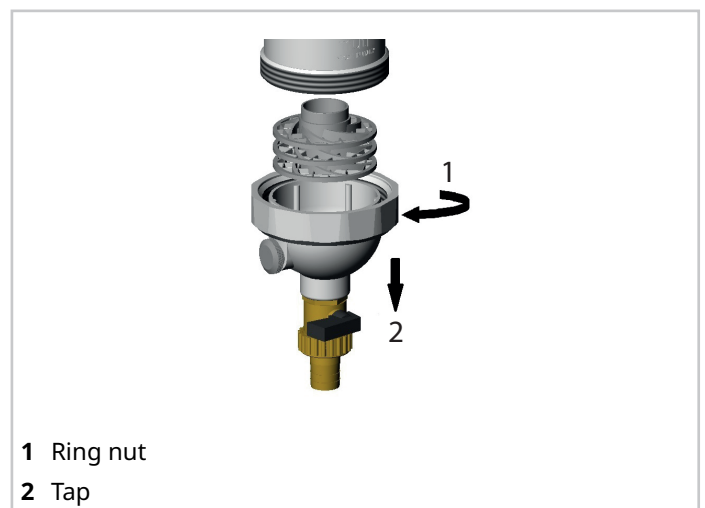

- ⚠ Check pressure of the plant.

12.14 Safety valve

Almost all leaks are caused by impurities deposited inside the valve:

- ▶ check the safety valve for leakage
- ▶ check that the pressure relief valve pipe is correctly positioned for draining the water
- ▶ check that the safety valve pipe is free from obstruction

To carry out a wash:

- ▶ manually open the valve
- ▶ rotate the knob in the sense indicated by the arrow in the knob

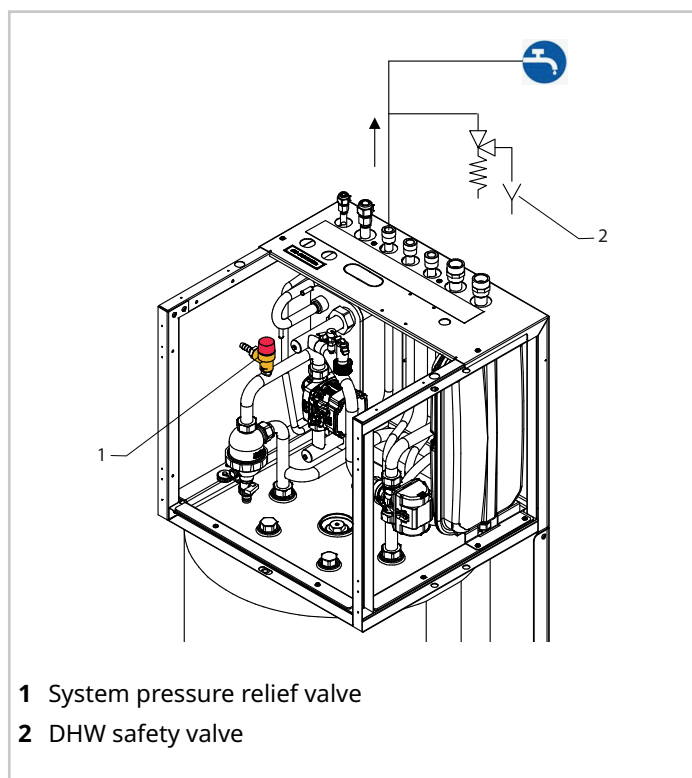

- ⚠ Pay attention to possible scalding from the hot water coming out of the valve.
- ⚠ It's normal if some water drops from the hole of safety valve during operation.
- ⚠ But, if there is a great amount of water, call your service agent for instructions.

12.15 Valve motor assembly

Should the motor be disassembled from the valve body, reassemble it following the instructions.

Ensure that:

- ▶ the lever is at the top (DHW)
- ⚠ Motion from the lever from "low" to "high" can only be done electrically (set the unit in DHW operation).
- ⚠ Fitting the valve motor with the lever "down" risks breaking the valve.

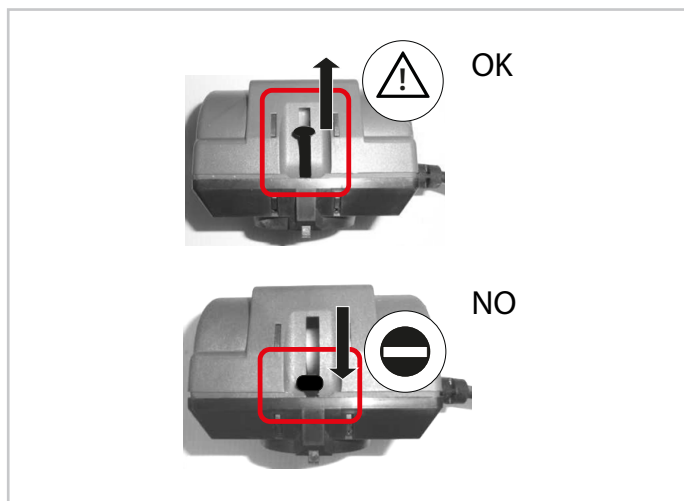

- ▶ place the motor on the valve body
- ▶ turn the motor body to lock it

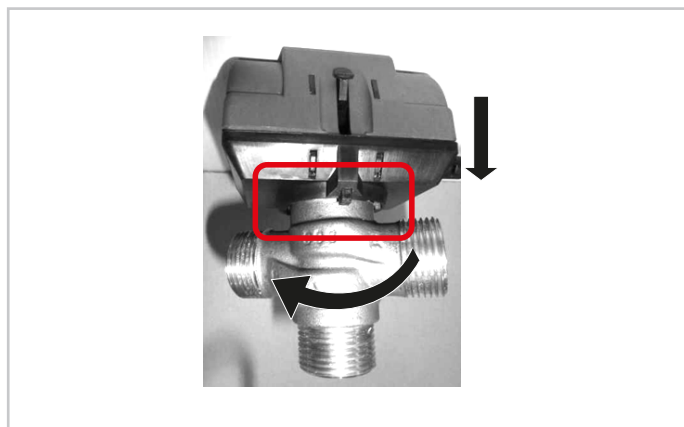

12.16 Anode replacement

Magnesium sacrificial anodes protect the water tank from corrosion.

Anode check:

- ▶ disconnect the power supply
- ▶ close the water inlet tap located on the system
- ▶ open the hot water tap to drop the pressure inside the water tank
- ▶ connect a pipe to the drain tap
- ▶ direct it towards a suitable drain or collection tank
- ▶ open the drain tap
- ▶ empty the water tank to the point indicated in the figure
- ▶ pull out the anode
- ▶ replace it with a new one and ensure that it is perfectly sealed
- ▶ check that there are no water leaks from the sleeve
- ▶ open the water inlet tap until water flows out of the outlet tap, then close the tap
- ▶ turn on and restart the unit

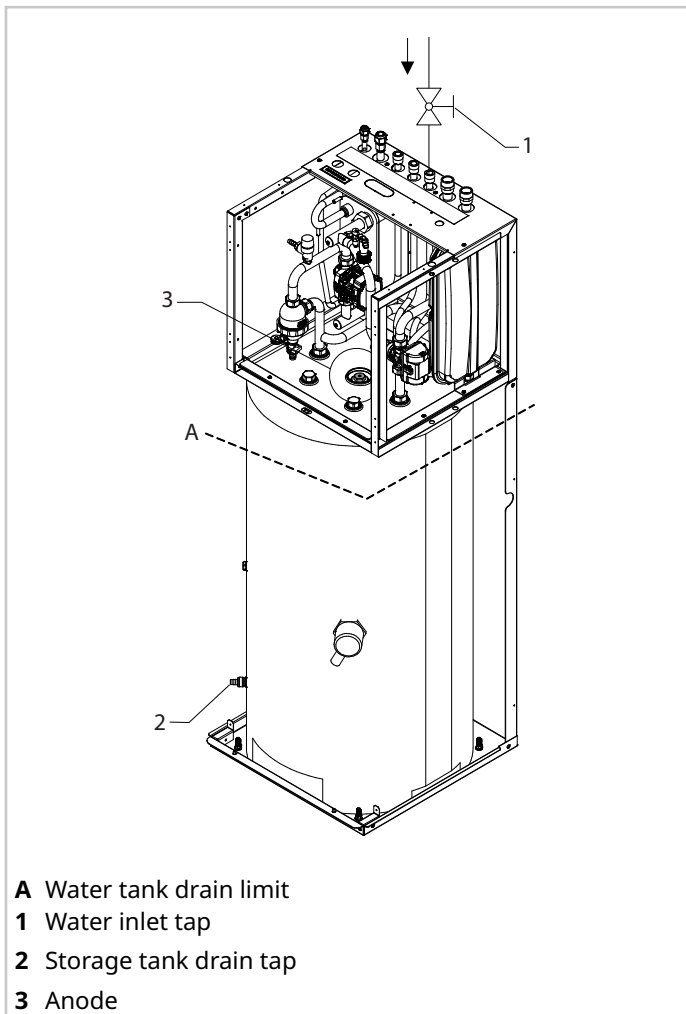

The anode must be:

- checked every 6 to 12 months
- replaced every 2 to 3 years

 Check its wear, replace if $\varnothing < 10 - 15$ mm.

 Possible burns, the outlet water temperature can be very hot.

12.17 Fan

External unit

Check:

- ▶ that the fan and its protection grilles are fixed properly
- ▶ the fan bearings (anomalies are indicated by abnormal noise and vibrations)
- ▶ the terminal protection covers are closed and the cable holders are properly positioned

Access to the fan

- ▶ remove the screws

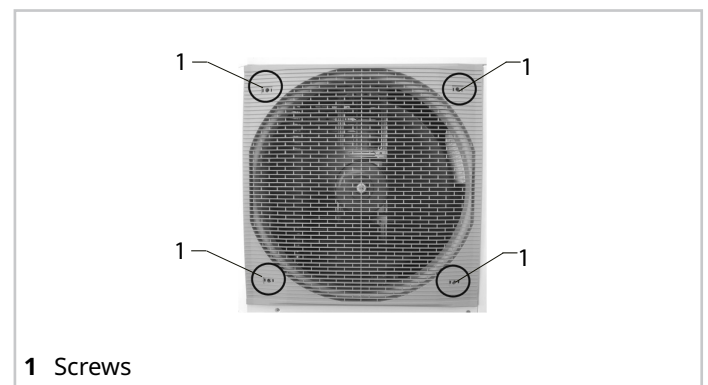

 Pay attention to avoid a possible hand injury.

12.18 Condensate drain

External unit

Dirt or scale can give rise to clogging.

- ▶ periodically clean with suitable products
- ▶ once cleaning is completed, pour water inside the drain pan to check the regular outflow

12.19 Air coil

External unit

The coil must allow maximum thermal exchange, therefore, the surface must be clear from dirt and scaling.

- ▶ clean the air inlet side
- ▶ use a soft brush, vacuum dirt exhauster, pressurised air jet or high-pressure washer
- ▶ keep the jet parallel to the fins to avoid damage

- check that the aluminium fins are not bent or damaged, if they are, contact an authorised service centre which will "comb" the coil to restore optimal air flow

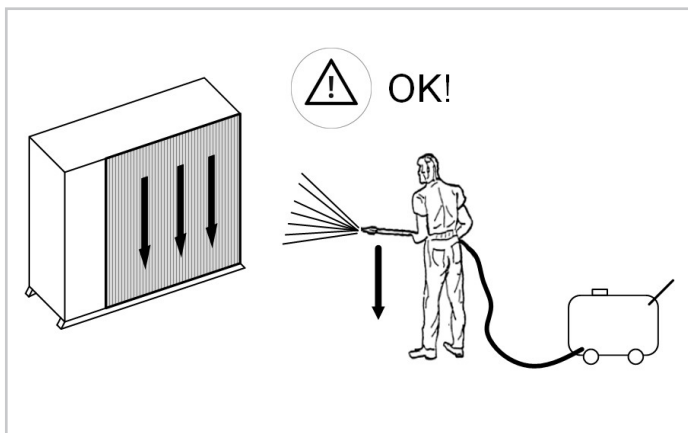
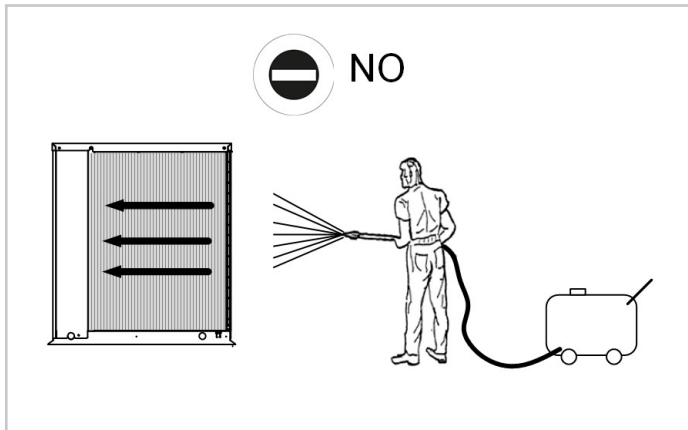



- ⚠ Accidental contact with the exchanger fins can cause cutting injuries, use protective gloves.

13. Decommissioning

13.1 Disconnection

 Before performing any work, carefully read: SAFETY WARNINGS FOR OPERATIONS ON UNITS CONTAINING R-32

 Avoid leak or spills into the environment.

 Before disconnecting the unit, the following must be recovered, if present:

- refrigerant gas
- Anti-freeze solutions in the hydraulic circuit

 Awaiting decommissioning and disposal, the unit can also be stored outdoors, as bad weather and rapid changes in temperature do not harm the environment provided that the electric, cooling and hydraulic circuits of the unit are intact and closed.

of which are to be collected;

- mechanical and electrical parts to be separated and disposed of as authorised.

When machine components to be replaced for maintenance purposes are removed or when the entire unit reaches the end of its life and needs to be removed from the installation, waste should be separated by its nature and disposed of by authorised personnel at existing collection centres.



13.1.1 WEEE INFORMATION

The manufacturer is registered on the EEE National Register, in compliance with implementation of Directive 2012/19/ EU and relevant national regulations on waste electrical and electronic equipment.

This Directive requires electrical and electronic equipment to be disposed of properly.

Equipment bearing the crossed-out wheelie bin mark must be disposed of separately at the end of its life cycle to prevent damage to human health and to the environment.

Electrical and electronic equipment must be disposed of together with all of its parts.

To dispose of "household" electrical and electronic equipment, the manufacturer recommends you contact an authorised dealer or an authorised ecological area.

"Professional" electrical and electronic equipment must be disposed of by authorised personnel through established waste disposal authorities around the country.

In this regard, here is the definition of household WEEE and professional WEEE:

WEEE from private households: WEEE originating from private households and WEEE which comes from commercial, industrial, institutional and other sources which, because of its nature and quantity, is similar to that from private households. Subject to the nature and quantity, where the waste from EEE was likely to have been by both a private household and users of other than private households, it will be classed as private household WEEE;

Professional WEEE: all WEEE which comes from users other than private households.

This equipment may contain:

- refrigerant gas, the entire contents of which must be recovered in suitable containers by specialised personnel with the necessary qualifications;
- lubrication oil contained in compressors and in the cooling circuit to be collected;
- mixtures with antifreeze in the water circuit, the contents

14. Residual risks

14.1 General

In this section the most common situations are indicated, as these cannot be controlled by the manufacturer and could be a source of risk situations for people or things.

14.2 Danger zone

- This is an area in which only an authorised operator may work.
- The danger zone is the area inside the unit which is accessible only with the deliberate removal of protections or parts thereof.

14.3 Handling

- The handling operations, if implemented without all of the protection necessary and without due caution, may cause the drop or the tipping of the unit with the consequent damage, even serious, to persons, things or the unit itself.
- Handle the unit following the instructions provided in the present manual re-garding the packaging and in compliance with the local regulations in force.
- Should the refrigerant leak please refer to the refrigerant "Safety sheet".

14.4 Installation

Remember that:

- incorrect installation of the unit can lead to water leaks, condensate accumulation, refrigerant leakage, electric shock, fire, malfunction or damage to the unit itself
- installation of the unit in a place where even infrequent flammable gas leaks are possible and the accumulation of these gases in the area around the unit can cause explosions and fires
- installation of the unit in a place that is not suitable to support its weight and/or provide adequate anchorage may cause it to fall and/or tip over, resulting in damage to property, people or the unit itself

Check:

- the location of the unit carefully
- that the installation is only carried out by qualified technical personnel and the instructions in this manual and current local regulations are followed
- the location of the unit carefully

 Easy access to the unit by children, unauthorised persons or animals may be the source of accidents, some serious.

 Install the unit in areas which are only accessible to authorised person and/or provide protection against intrusion into the danger zone.

14.4.1 General risks

 Smell of burning, smoke or other signals of serious anomalies may indicate a situation which could cause damage to people, things or the unit itself.

In this case:

- electrically disconnect the unit
- contact the authorised service centre to identify and solve the problem causing the anomaly

 Accidental contact with exchange batteries, compressors, air delivery tubes or other components may cause injuries and/or burns.

 Always wear suitable clothing including protective gloves to work inside the danger zone.

 Maintenance and repair operations carried out by non-qualified personnel may cause damage to persons, things or the unit itself.

 Always contact the qualified assistance centre.

 Failing to close the unit panels or failure to check the correct tightening of all of the panelling fixing screws may cause damage to persons, things or the unit itself.

 Periodically check that all of the panels are correctly closed and fixed.

 If there is a fire the temperature of the refrigerant could reach values that increase the pressure to beyond the safety valve with the consequent possible projection of the refrigerant itself or explosion of the circuit parts that remain isolated by the closure of the tap.

 Do not remain in the vicinity of the safety valve and never leave the refrigerating system taps closed.







14.4.2 Electric parts

 An incomplete attachment line to the electric network or with incorrectly sized cables and/or unsuitable protective devices can cause electric shocks, intoxication, damage to the unit or fires.

 Carry out all of the work on the electric system referring to the electric layout and the present manual ensuring the use of a system thereto dedicated.

 An incorrect fixing of the electric components cover may lead to the entry of dust, water etc inside and may consequently electric shocks, damage to the unit or fires.

 Always fix the unit cover properly.

-  When the metallic mass of the unit is under voltage and is not correctly connected to the earthing system it may be as source of electric shock and electrocution.
-  Always pay particular attention to the implementation of the earthing system connections.
-  Contact with parts under voltage accessible inside the unit after the removal of the guards can cause electric shocks, burns and electrocution.
-  Open and padlock the general isolator prior to removing the guards and signal work in progress with the appropriate sign.
-  Contact with parts that could be under voltage due to the start up of the unit may cause electric shocks, burns and electrocution.
-  When voltage is necessary for the circuit open the isolator on the attachment line of the unit itself, padlock it and display the appropriate warning sign.
-  Defects in tubing, the attachments or the removal parts may cause a leak or water projection with the consequent damages to people, things or shortcircuit the unit.







14.4.3 Moving parts

-  Contact with the transmissions or with the fan aspiration can cause injuries.

Remember that:

- before accessing inside the unit, open the disconnecter switch on the unit connection line, padlock it and display the appropriate warning sign
- contact with fans can cause injury.
- before removing the protection grilles or fans, open the disconnecter switch on the unit connection line, padlock it and display the appropriate warning sign.

14.5 Refrigerant

-  The intervention of the safety valve and the consequent expulsion of the gas refrigerant may cause injuries and intoxication.
-  Always wear suitable clothing including protective gloves and eyeglasses for operations inside the danger zone.
-  Should the refrigerant leak please refer to the refrigerant "Safety sheet".
-  Contact between open flames or heat sources with the refrigerant or the heating of the gas circuit under pressure (e.g. during welding operations) may cause explosions or fires.
-  Do not place any heat source inside the danger zone.
-  The maintenance or repair interventions which include welding must be carried out with the system off.

14.6 Hydraulic parts

15. Advanced applications

15.1 Units connected in cascade

Cascade operation allows up to 6 units to be connected in parallel, thereby ensuring that the system is fully reliable and efficient.

The Master unit controls and displays the parameters of the entire system on its User Interface, activating the Slave units when its capacity is not enough to fulfil the system load.

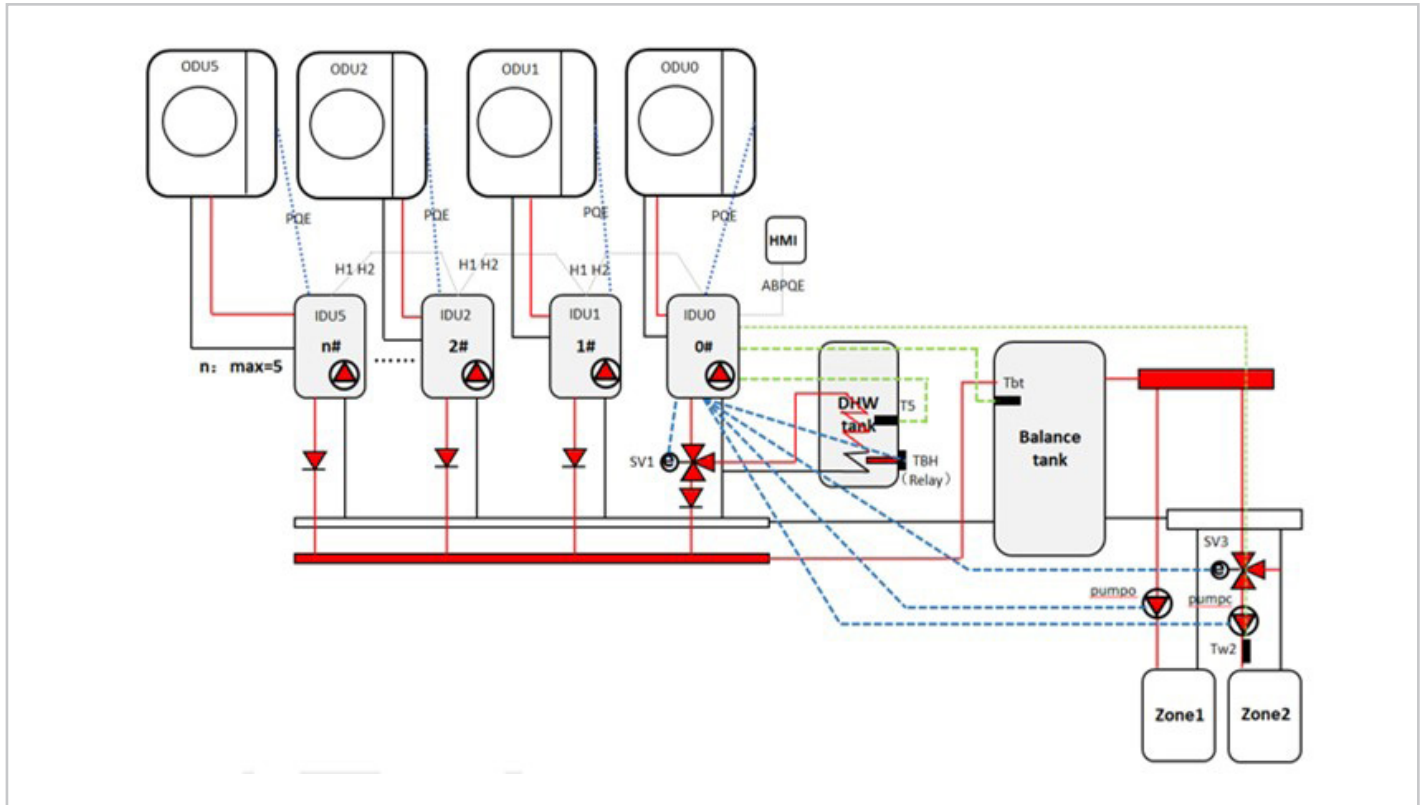

IDU0	Master (indoor unit)
IDU1..	Slave (max 5 indoor units)
ODU0..	External unit
HMI	Keypad
SV1	3-way valve (indoor unit)
T5	Temperature probe
DWH	DHW tank
TBH	Heating heater
Balance tank	Inertial tank
Tbt	Inertial tank temperature probe
pumpo	Zone 1 pump
SV3	Zone 2 mixing valve (low temperature)
pumpc	Zone 2 pump
Tw2	zone 2 temperature probe
Zone1	Fan coil
Zone2	Underfloor heating

- enter the address and press “UNLOCK” to confirm.
- power off the Slave unit and remove the HMI from the unit.

Connections

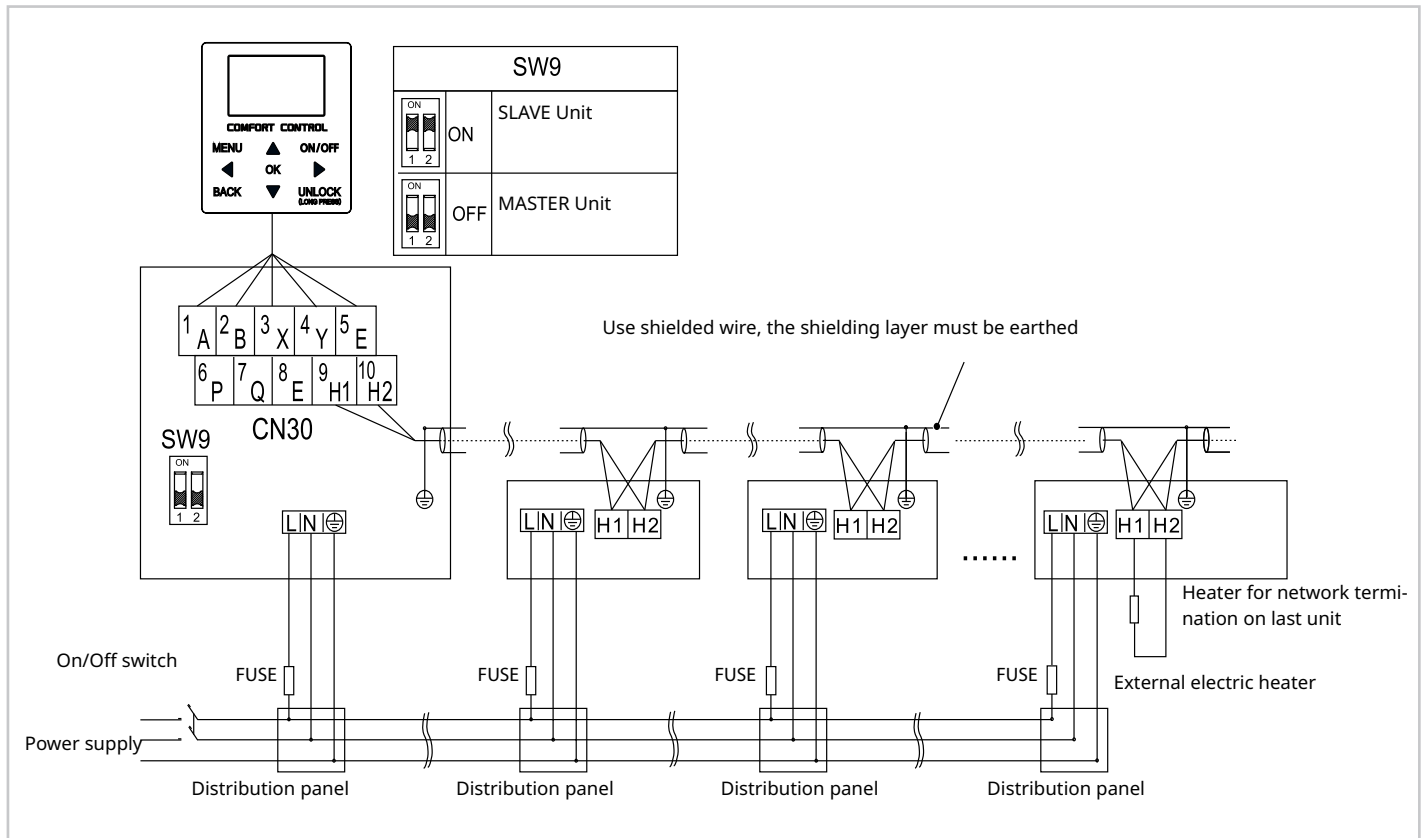

The Slave units are automatically addressed and they do not need to be addressed manually.

For the automatic addressing function to work properly, the units must be connected to the same power supply, shielded and then turned on together.

Notes:

- on the Master unit dip-switch SW9 must be set to “ON”.
- only the Master unit can be connected to the HMI and during operations the Slave units must not be connected to the HMI.

In a cascade system only the Master unit can:

- control the main sensors (Tbtu, TbtI, T5, Tw2, Tsolar, Ta).
- control the input signals (such as M1 / M2, room thermostat, adapter board, smart grid, solar input, etc.).
- monitor external elements (SV1, SV2, SV3, PUMPO, PUMPC, PUMPD, PUMPS, AHS, TBH, etc.).

Note:

The Slave unit can only control its T1 probe (outlet water temperature) and IBH probe (if its dip-switch is set to ON).

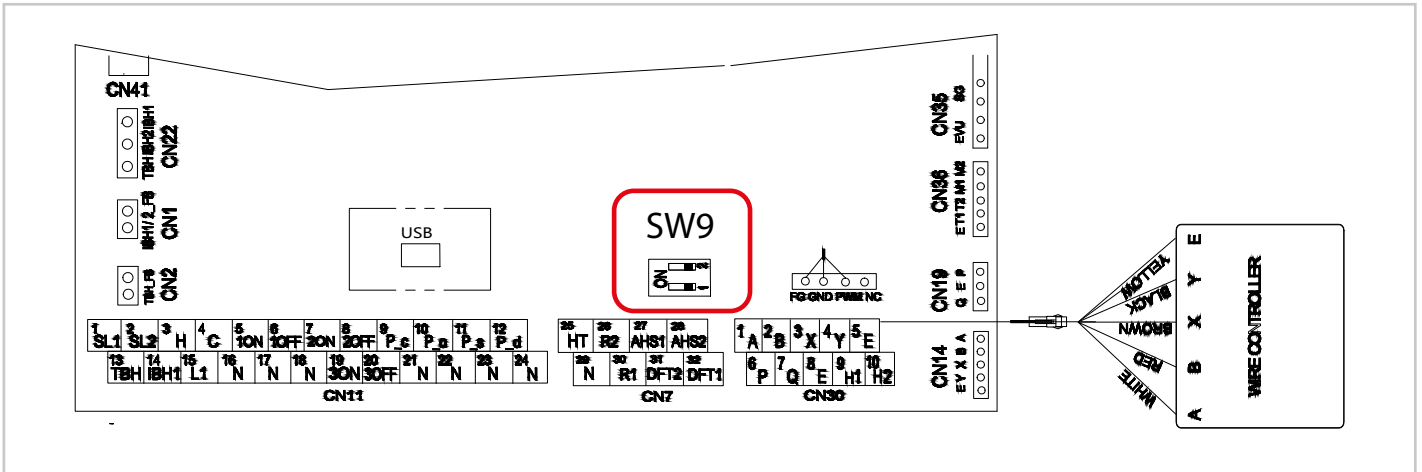

16. Technical data

SIZE	2.1		3.1		4.1		5.1		6.1*	7.1*	8.1*
	190 L	250 L	190 L	250 L	190 L	250 L	190 L	250 L	250 L	250 L	250 L
WATER TANK CAPACITY											
Heating											
Air 7°C - Water 35°C											
Nominal heating capacity / max	1	kW	4,32 / 6,26	6,18 / 7,41	8,30 / 9,11	10,09 / 10,3	12,13 / 14,60	14,51 / 15,5	16,01 / 16,80		
Total power input	1	kW	0,80	1,19	1,56	2,01	2,42	3,09	3,52		
COP	1	-	5,42	5,21	5,31	5,01	5,00	4,70	4,55		
Water flow-rate	1	l/s	0,21	0,30	0,41	0,49	0,57	0,67	0,75		
Nominal available pressure	1	kPa	31,2	36,5	33,1	31,0	25,7	31,7	22,6		
Maximum available pressure	1	kPa	69 95	62 90	47 83	31 76	70	55	39		
Air -7°C - Water 35°C											
Nominal heating capacity / max	2	kW	4,17 / 6,25	6,05 / 6,97	7,33 / 8,35	8,20 / 9,30	10,49 / 13,85	12,23 / 14,09	13,43 / 14,33		
Total power input	2	kW	1,32	2,01	2,27	2,67	3,36	4,33	4,90		
COP	2	-	3,16	3,00	3,23	3,07	3,13	2,82	2,74		
Water flow-rate	2	l/s	0,22	0,29	0,34	0,40	0,56	0,62	0,70		
Nominal available pressure	2	kPa	35,0	39,8	34,0	31,7	65,8	63,1	47,7		
Maximum available pressure	2	kPa	69 94	64 91	58 88	49 84	71	63	49		
Air 7°C - Water 45°C											
Nominal heating capacity / max	3	kW	4,16 / 5,96	6,03 / 7,13	8,22 / 8,98	10,01 / 10,30	12,30 / 14,50	14,00 / 15,70	16,01 / 16,60		
Total power input	3	kW	1,06	1,57	2,08	2,59	3,24	3,84	4,45		
COP	3	-	3,93	3,83	3,95	3,86	3,80	3,65	3,60		
Water flow-rate	3	l/s	0,19	0,30	0,39	0,49	0,60	0,67	0,76		
Nominal available pressure	3	kPa	32,3	36,4	34,9	31,0	51,6	41,8	21,7		
Maximum available pressure	3	kPa	70 95	63 90	51 85	31 76	65	55	38		
Air 7°C - Water 55°C											
Nominal heating capacity / max	4	kW	4,08 / 5,74	5,94 / 6,90	7,50 / 7,80	9,60 / 9,72	12,07 / 13,90	13,85 / 14,50	16,00 / 16,20		
Total power input	4	kW	1,36	1,93	2,35	3,10	3,89	4,53	5,52		
COP	4	-	3,00	3,07	3,19	3,10	3,10	3,05	2,90		
Water flow-rate	4	l/s	0,12	0,18	0,23	0,29	0,36	0,41	0,48		
Nominal available pressure	4	kPa	35,6	33,4	31,2	33,6	14,1	16,5	17,4		
Maximum available pressure	4	kPa	70 98	70 96	69 94	63 91	90	105	80		
COOLING											
Air 35°C - Water 18°C											
Nominal/max cooling capacity	5	kW	4,55 / 6,88	6,44 / 7,65	8,10 / 11,13	10,00 / 12,03	12,06 / 15,02	13,79 / 15,30	14,84 / 16,38		
Total power input	5	kW	0,75	1,23	1,58	2,10	3,00	3,73	4,07		
EER	5	-	6,08	5,24	5,12	4,77	4,02	3,70	3,65		
Water flow-rate	5	l/s	0,22	0,32	0,38	0,48	0,60	0,63	0,71		
Nominal available pressure	5	kPa	34,9	34,8	34,6	10,6	13,1	16,3	15,1		
Maximum available pressure	5	kPa	69 94	61 89	51 85	32 76	65	61	48		
Air 35°C - Water 7°C											
Nominal/max cooling capacity	6	kW	4,26 / 6,14	6,25 / 6,39	7,46 / 7,94	9,10 / 9,10	11,80 / 11,80	12,86 / 12,86	14,2 / 14,2		
Total power input	6	kW	1,22	2,02	2,24	2,94	4,29	5,04	5,80		
EER	6	-	3,50	3,09	3,33	3,09	2,75	2,55	2,45		
Water flow-rate	6	l/s	0,20	0,29	0,36	0,43	0,54	0,59	0,64		
Nominal available pressure	6	kPa	5,8	36,1	34,3	36,8	18,1	20,3	25,1		
Maximum available pressure	6	kPa	70 95	64 91	56 87	43 82	74	67	60		

1. User side water inlet/outlet temperature 30/35 °C, source side air 7°C R.H. = 85% Heating capacity, Total power input and COP data according to EN 14511:2018.

2. User side water inlet/outlet temperature 30/35 °C, source side air -7°C Heating capacity, Total power input and COP data according to EN 14511:2018.

3. User side water inlet/outlet temperature 40/45 °C, source side air 7°C R.H. = 85% Heating capacity, Total power input and COP data according to EN 14511:2018.

4. User side water inlet/outlet temperature 47/55 °C, source side air 7°C R.H. = 85% Heating capacity, Total power input and COP data according to EN 14511:2018.

5. User side water inlet/outlet temperature 18/23 °C, source side air 35°C Heating capacity, Total power input and COP data according to EN 14511:2018.

6. User side water inlet/outlet temperature 7/12 °C, source side air 35°C Heating capacity, Total power input and COP data according to EN 14511:2018.

The product is conforming with the European ErP Directives, which include Commission Delegated Regulation (EU) no. 811/2018, Commission Delegated Regulation no. 813/2018, Average Climate, High Temperature 47/55°C.

* All data are calculated with zero height difference and equivalent length of 7m

Technical data

SIZE	2.1		3.1		4.1		5.1		6.1*	7.1*	8.1*
WATER TANK CAPACITY	190 L	250 L	190 L	250 L	190 L	250 L	190 L	250 L	250 L	250 L	250 L
ERP											
Average climatic conditions - Heat pump for Average temperature application											
Nominal power	7	kW	4	6	7	9	12	13	13	13	13
SCOP	7	-	3.32	3.54	3.72	3.73	3.56	3.52	3.48	3.48	3.48
Generator energy class	7	-	A++	A++	A++	A++	A++	A++	A++	A++	A++
η_s	7	%	130	138	146	146	139	138	136	136	136
System energy class	7	-	A++	A++	A++	A++	A++	A++	A++	A++	A++
η_s	7	%	135	143	151	151	144	143	141	141	141
Average climatic conditions - Heat pump for Low temperature application											
Nominal power	8	kW	5	6	8	10	12	14	16	16	16
SCOP	8	-	5,13	5,15	5,32	5,27	5,00	4,91	4,89	4,89	4,89
Generator energy class	8	-	A+++	A+++	A+++	A+++	A+++	A+++	A+++	A+++	A+++
η_s	8	%	202	203	210	208	196	193	193	193	193
System energy class	8	-	A+++	A+++	A+++	A+++	A+++	A+++	A+++	A+++	A+++
η_s	8	%	207	208	215	213	201	198	198	198	198
Average climatic conditions - Heat pump for application with Fan coil											
Nominal power	9	kW	4	6	7	9	12	13	14	14	14
SEER	9	-	5,09	5,42	5,95	6,01	5,16	5,10	4,87	4,87	4,87
Generator energy class	9	-	A+++	A+++	A+++	A+++	A+++	A+++	A+++	A+++	A+++
η_s	9	%	201	214	235	238	203	201	192	192	192
Heat pump for Domestic Hot Water application											
Declared load profile	10	-	L	XL	L	XL	L	XL	L	XL	XL
η_{wh}	10	%	120	123	120	123	116	125	116	125	124
Domestic water energy class	10	-	A+	A+	A+	A+	A+	A+	A+	A+	A+

- The product is conforming with the European ErP Directives, which include Commission Delegated Regulation (EU) no. 811/2018 and Commission Delegated Regulation no. 813/2018. Average climate, Medium temperature 47/55°C
- The product is conforming with the European ErP Directives, which include Commission Delegated Regulation (EU) no. 811/2018 and Commission Delegated Regulation no. 813/2018. Average climate, Low temperature 30/35°C
- The product is conforming with the European ErP Directives, which include Commission Delegated Regulation (EU) no. 811/2018 and Commission Delegated Regulation no. 813/2018. Average climate, Low temperature 12/7°C
- Data according to EN 16147:2017

* All data are calculated with zero height difference and equivalent length of 7m.

Construction characteristics - Outdoor unit

SIZE	2.1		3.1		4.1		5.1		6.1	7.1	8.1
Characteristics											
Compressor	Twin Rotary										
Refrigerant	R32										
Refrigerant charge	kg	1.50	1.50	1.65	1.65	1.84	1.84	1.84	1.84	1.84	1.84
GWP	t CO2	675	675	675	675	675	675	675	675	675	675
Tons of equivalent CO2 (*)	tt	1.02	1.02	1.11	1,11	1,24	1,24	1,24	1,24	1,24	1,24
Oil charge	l	0,46	0,46	0,46	0,46	1,10	1,10	1,10	1,10	1,10	1,10
Type of fan	Assiale										
Nominal airflow	m3/h	2770	2770	4030	4030	4060	4060	4060	4060	4060	4060
Outdoor unit sound pressure at 1 metre	1 dB(A)	42	44	45	47	50	51	53	53	53	53
Sound power	1 dB(A)	55	57	58	60	63	64	66	66	66	66
Dimensions											
Operation (L x W x H)	mm	986x426x712	986x426x712	1140x523x866	1140x523x866	1140x523x866	1140x523x866	1140x523x866	1140x523x866	1140x523x866	1140x523x866
Packaging (L x W x H)	mm	1065x485x800	1065x485x800	1180x560x890	1180x560x890	1180x560x890	1180x560x890	1180x560x890	1180x560x890	1180x560x890	1180x560x890
Operating weight 230M / 400TN	2 kg	58	58	77	77	96/112	96/112	96/112	96/112	96/112	96/112
Shipping weight 230M / 400TN	2 kg	64	64	88	88	110/125	110/125	110/125	110/125	110/125	110/125

- Sound power levels are determined using the intensimetric method (UNI EN ISO 9614-2). Data referring to the following conditions at full load: Heating - user side water inlet/outlet 47/55°C, source side air 7°C. Cooling - user side water inlet/outlet 12/7°C, source side air 35°C.
- Power supply 220-240V ~ 50Hz / Power supply 380-415V 3N~ 50Hz

(*) It contains fluorinated greenhouse gases

Construction characteristics - Indoor unit

SIZE			A - 190 L	A - 250 L	B - 250 L
System characteristics					
Maximum system circuit pressure		bar	3,0	3,0	3,0
System expansion tank	1	l	8,0	8,0	8,0
Expansion tank pre-charge		bar	1,0	1,0	1,0
System water connections		inch	1"	1"	1"
DHW Characteristics					
Type of Tank			Glazed Steel	Glazed Steel	Glazed Steel
Domestic hot water Tank Volume		l	190	250	250
Internal coil exchange surface		m ²	2,0	2,0	2,0
Water tank leakage		W/K (kWh/24h)	1.81 (1.95)	2.04 (2.20)	2.04 (2.20)
DHW safety electric heater		kW	2,0	2,0	2,0
Maximum DHW circuit pressure	2	bar	10,0	10,0	10,0
Recommended DHW expansion tank	3	l	12,0	16,0	16,0
DHW water connections		inch	3/4"	3/4"	3/4"
Dimensions					
Operation (L x W x H)		mm	600 x 615 x 1774	600 x 615 x 2084	600 x 615 x 2084
Packaging (L x W x H)		mm	660 x 690 x 1890	660 x 690 x 2190	660 x 690 x 2190
Operation weight		kg	359	419	421
Shipping weight		kg	187	192	194

1. Sufficient volume up to a maximum of 60 litres of system water content
2. It is mandatory for the installer to install the pressure relief valve on the DHW side
3. It is mandatory for the installer to install the DHW expansion valve. The volumes indicated are for reference purposes only.

Hydraulic data - Indoor unit + Outdoor unit

SIZE			2.1		3.1		4.1		5.1		6.1		7.1		8.1	
Characteristics			190 L	250 L	190 L	250 L	190 L	250 L	190 L	250 L	250 L	250 L	250 L	250 L	250 L	
Minimum system water content	1	l	40		40		40		40		40		40		40	
Minimum water flow rate allowed		l/s	0,16		0,16		0,16		0,16		0,16		0,16		0,16	
Maximum water flow rate allowed		l/s	0,61	0,86	0,61	0,86	0,61	0,86	0,61	0,86	0,92	0,92	0,92	0,92	0,92	
Net boiler capacity		l	182	240	182	240	182	240	182	240	240	240	240	240	240	
DHW tank setpoint		°C	50	50	50	50	50	50	50	50	50	50	50	50	50	
Water mixed at 40°C (V40)		l	204	269	204	269	204	269	204	269	269	269	269	269	269	
Heating time	2	h:min	02:30	02:25	02:30	02:25	02:08	02:05	02:08	02:05	01:46	01:46	01:46	01:46	01:46	
Energy consumption during heating	3	kWh	2,20	2,70	2,20	2,70	2,30	2,85	2,30	2,85	3,01	3,01	3,01	3,01	3,01	

1. Consider the water content of the area with less volume
2. Time required to bring the water volume of the tank from a temperature of 10°C to a temperature of 50°C
3. Energy consumption to bring the water volume of the tank from a temperature of 10°C to a temperature of 50°C

Outdoor unit sound levels

Standard mode

SIZES	Sound power level								Sound pressure level dB(A)	Sound power level dB(A)
	Octave band (Hz)									
	63	125	250	500	1000	2000	4000	8000		
2.1	46	49	49	52	52	46	37	27	42	55
3.1	49	48	50	55	53	48	39	30	44	57
4.1	36	51	53	56	55	49	44	30	45	58
5.1	37	56	53	57	57	51	47	36	47	60
6.1	44	53	54	60	58	55	52	51	50	63
7.1	44	54	55	60	59	57	56	54	51	64
8.1	46	58	57	60	61	59	54	51	53	66

Sound levels refer to a unit at full load, under nominal test conditions. Data referring to the following conditions: user side exchanger water inlet/outlet 47/55°C source side exchanger air inlet 7°C.

The sound pressure level refers to 1 m. from the unit outer surface operating in open field.

Sound power levels are determined using the intensimetric method (UNI EN ISO 9614-2)

Silent mode

SIZES	Sound pressure level	Sound power level
	dB(A)	dB(A)
2.1	40	53
3.1	40	53
4.1	42	55
5.1	42	55
6.1	46	59
7.1	47	60
8.1	48	61

Liund levels refer to a unit at full load, under nominal test conditions.

For maximum capacity delivered in silent mode use a correction factor of 0.8

Data referring to the following conditions: user side exchanger water inlet/outlet 47/55°C source side exchanger air inlet 7°C.

The sound pressure level refers to 1 m. from the unit outer surface operating in open field.

Sound power levels are determined using the intensimetric method (UNI EN ISO 9614-2)

Super Silent mode

SIZES	Sound pressure level	Sound power level
	dB(A)	dB(A)
2.1	37	50
3.1	38	51
4.1	39	52
5.1	39	52
6.1	41	54
7.1	41	54
8.1	41	54

Sound levels refer to a unit at full load, under nominal test conditions.

For maximum capacity delivered in silent mode use a correction factor of 0.6

Data referring to the following conditions: user side exchanger water inlet/outlet 47/55°C source side exchanger air inlet 7°C.

The sound pressure level refers to 1 m. from the unit outer surface operating in open field.

Sound power levels are determined using the intensimetric method (UNI EN ISO 9614-2)

Operating range

Cooling

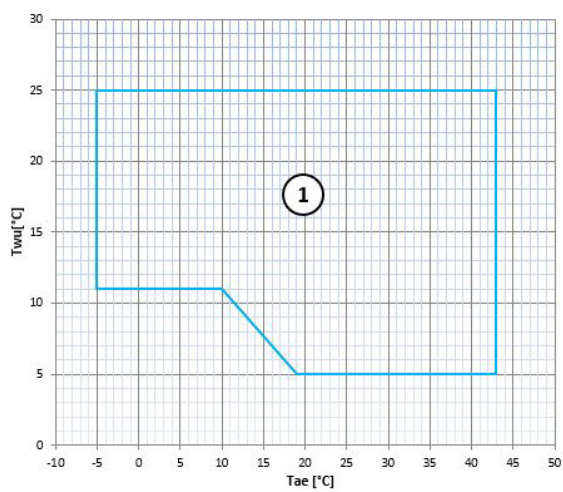

T_{wu} [°C] = Temperature of the outlet water from the exchanger
 T_{ae} [°C] = External exchanger inlet air temperature

1. Normal operating range

Heating

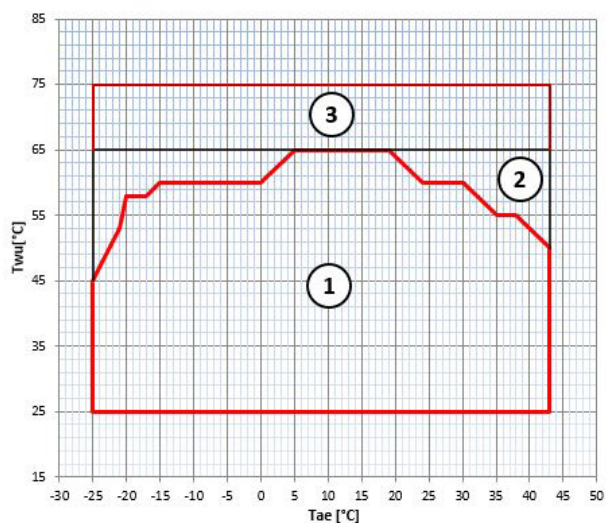

T_{wu} [°C] = Temperature of the outlet water from the exchanger
 T_{ae} [°C] = External exchanger inlet air temperature

1. Normal operating range
2. Operating range with additional electric heater option
3. Hybrid system operating range

In the configuration with the additional electric heater, the extension of the limits varies according to the power output of the heater chosen.

Dimensional

Indoor unit (190 L)

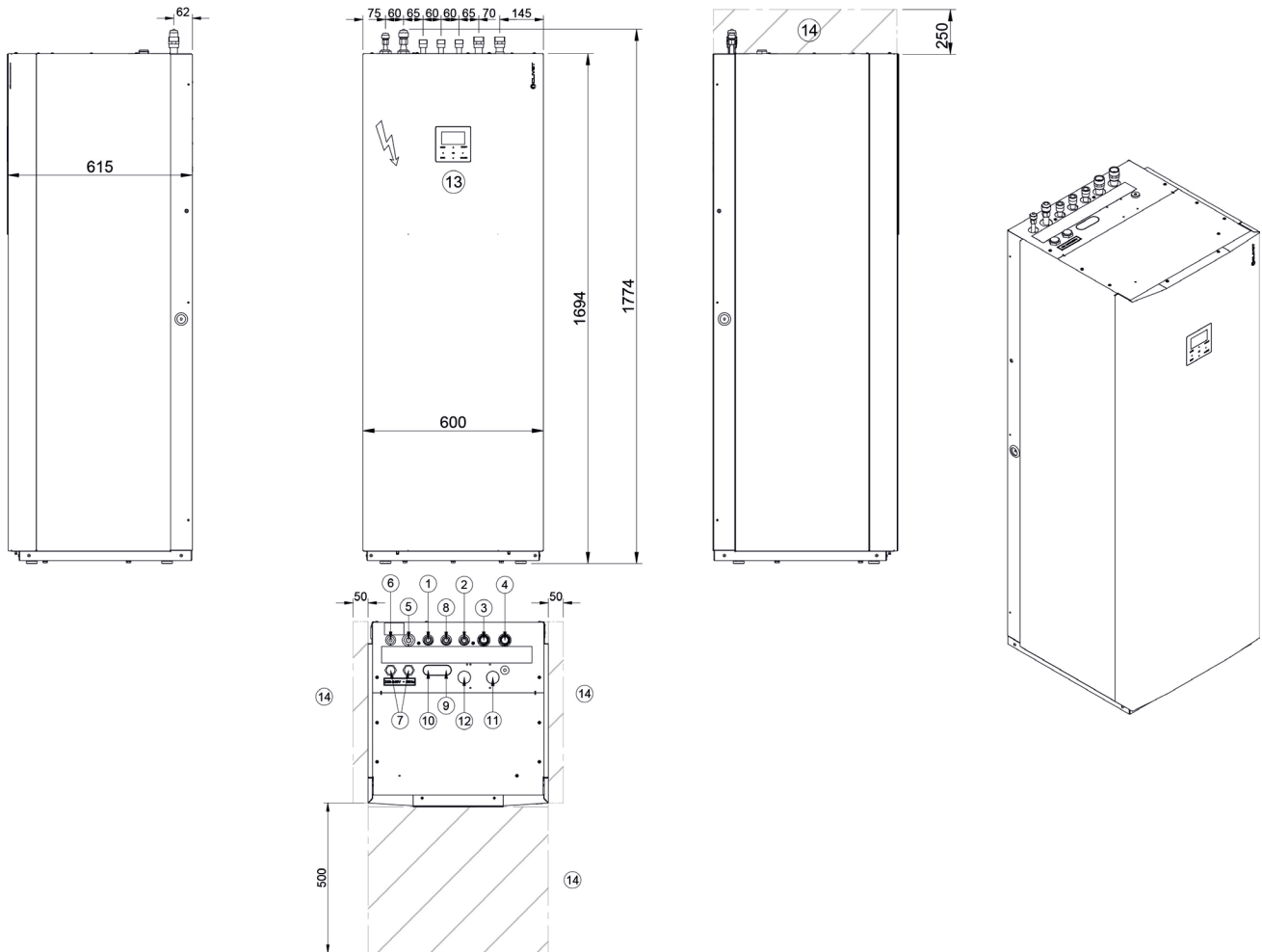

1. Domestic hot water outlet M 3/4"
2. Water supply system inlet M 3/4"
3. Return from user side system M 1"
4. Supply to user side system M 1"
5. Suction connection 5/8" SAE
6. Liquid connection 3/8" SAE
7. Power input
8. DHW circulation circuit inlet M 3/4"
9. Return from solar system M 3/4" (optional accessory)
10. Supply to solar system M 3/4" (optional accessory)
11. Boiler return M 1" (optional accessory)
12. Boiler supply M 1" (optional accessory)
13. Unit control keypad
14. Functional spaces for standard unit

SIZE		190 L
Operation weight	kg	359
Shipping weight	kg	187

Indoor unit (250 L)

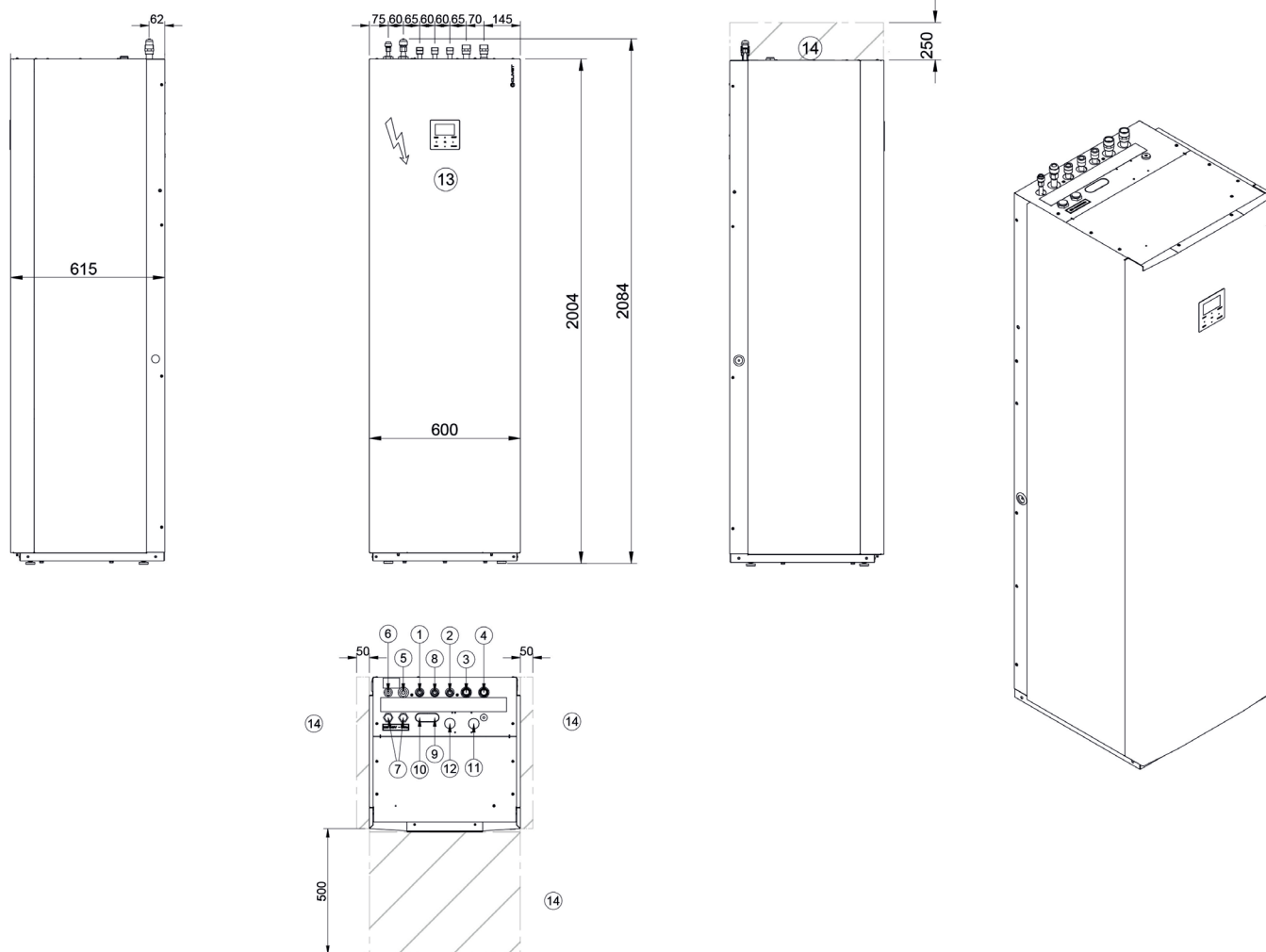

1. Domestic hot water outlet M 3/4"
2. Water supply system inlet M 3/4"
3. Return from user side system M 1"
4. Supply to user side system M 1"
5. Suction connection 5/8" SAE
6. Liquid connection 3/8" SAE
7. Power input
8. DHW circulation circuit inlet M 3/4"
9. Return from solar system M 3/4" (optional accessory)
10. Supply to solar system M 3/4" (optional accessory)
11. Boiler return M 1" (optional accessory)
12. Boiler supply M 1" (optional accessory)
13. Unit control keypad
14. Functional spaces for standard unit

RANGE		GABC	GBBC
SIZE		250 L	250 L
Operation weight	kg	419	421
Shipping weight	kg	192	194

External unit

Sizes 2.1-3.1

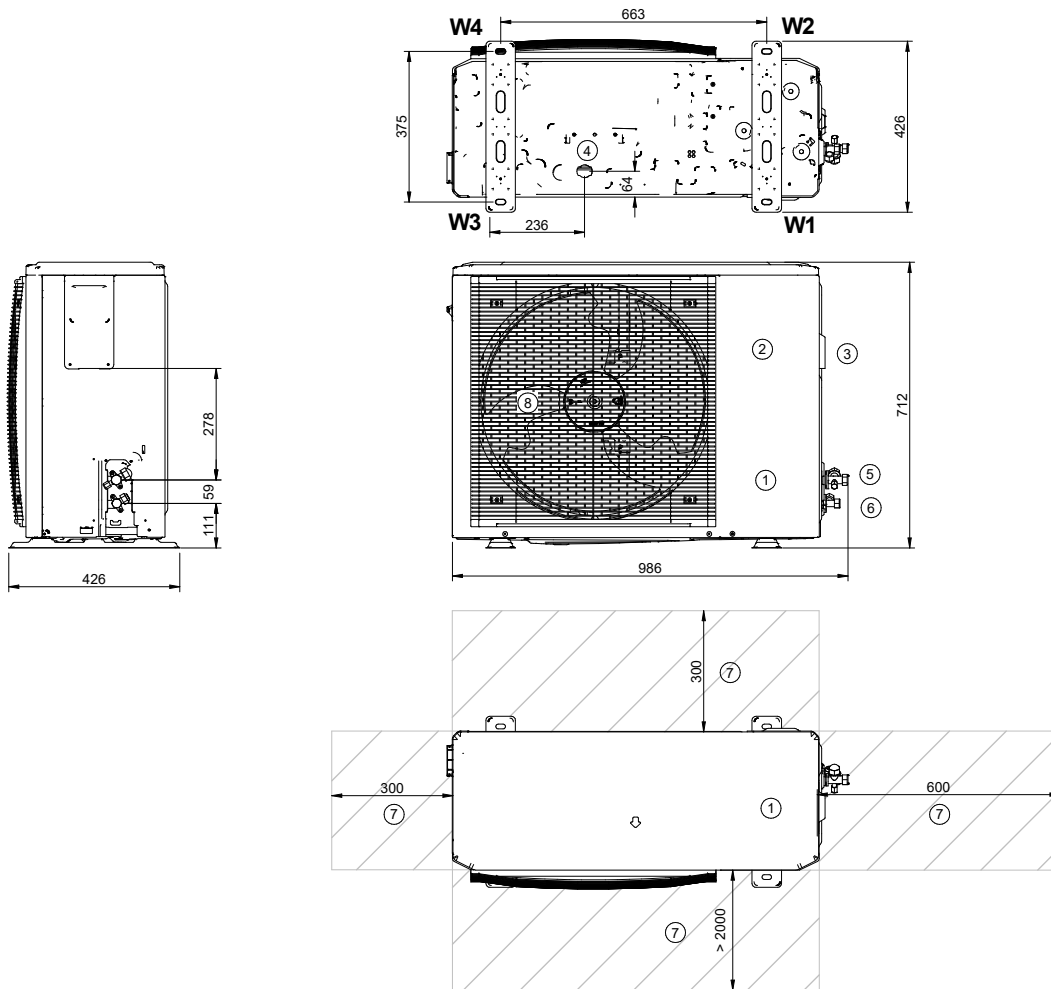

1. Compressor compartment
2. Electrical panel
3. Power input
4. Condensate drain
5. Gas connections (5/8")
6. Gas connections (1/4")
7. Functional spaces
8. Electric fan

SIZE		2.1	3.1
W1 Point of Support	kg	23,9	23,9
W2 Point of Support	kg	13,8	13,8
W3 Point of Support	kg	12,9	12,9
W4 Point of Support	kg	7,4	7,4
Operation weight	kg	58	58
Shipping weight	kg	64	64

External unit

Sizes 4.1-8.1

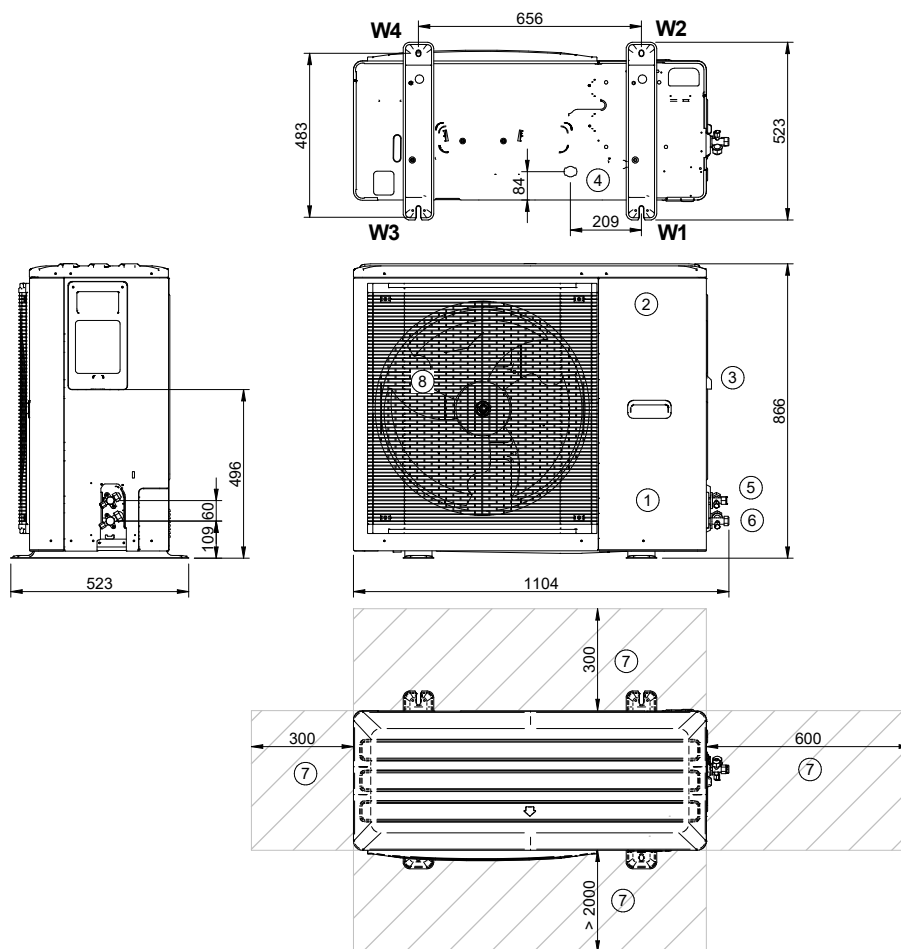

- 1. Compressor compartment
- 2. Electrical panel
- 3. Power input
- 4. Condensate drain
- 5. Gas connections (3/8")
- 6. Gas connections (5/8")
- 7. Functional spaces
- 8. Electric fan

SIZE		4.1 / 1PH	5.1 / 1PH	6.1 / 1PH	6.1 / 3PH	7.1 / 1PH	7.1 / 3PH	8.1 / 1PH	8.1 / 3PH
W1 Point of Support	kg	30	30	30,4	40,3	30,4	40,3	30,4	40,3
W2 Point of Support	kg	17,8	17,8	29,1	34,8	29,1	34,8	29,1	34,8
W3 Point of Support	kg	18,4	18,4	18,6	19,8	18,6	19,8	18,6	19,8
W4 Point of Support	kg	10,9	10,9	17,9	17,1	17,9	17,1	17,9	17,1
Operation weight	kg	77	77	96	112	96	112	96	112
Shipping weight	kg	88	88	110	125	110	125	110	125

17. Energy labels

Modello info prodotto /Product info template

Information requirements for heat pump space heaters and heat pump combination heaters. Informazioni obbligatorie per gli apparecchi a pompa di calore per il riscaldamento d'ambiente e gli apparecchi di riscaldamento misti a pompa di calore							
Model(s): / Modelli:				aa			
Air-to-water heat pump: / Pompa di calore aria/acqua:				ab			
Water-to-water heat pump: / Pompa di calore acqua/acqua:				ac			
Brine-to-water heat pump: / Pompa di calore salamoia/acqua:				ad			
Low-temperature heat pump: / Pompa di calore a bassa temperatura:				ae			
Equipped with a supplementary heater: / Con riscaldatore supplementare:				af			
Heat pump combination heater: / Apparecchio misto a pompa di calore:				ag			
Heat pump combination heater: / Apparecchio misto a pompa di calore: Parameters shall be declared for medium-temperature application, except for low-temperature heat pumps. For low-temperature heat pumps, parameters shall be declared for low-temperature application. / I parametri sono dichiarati per l'applicazione a temperatura media, tranne per le pompe di calore a bassa temperatura Per le pompe di calore a bassa temperatura, i parametri sono dichiarati per l'applicazione a bassa temperatura.							
Parameters shall be declared for average climate conditions. / I parametri sono dichiarati per condizioni climatiche medie.							
Item / Elemento	Symbol / Simbolo	Value / Valore	Unit / Unità	Item / Elemento	Symbol / Simbolo	Value / Valore	Unit / Unità
Rated heat output (*) / Potenza termica nominale (*)	<i>Prated</i>	ah	kW	Seasonal space heating energy efficiency / Efficienza energetica stagionale del riscaldamento d'ambiente	<i>η_s</i>	ai	%
Declared capacity for heating for part load at indoor temperature 20 °C and outdoor temperature T _j / Capacità di riscaldamento dichiarata a carico parziale, con temperatura interna pari a 20 °C e temperatura esterna T _j				Declared coefficient of performance or primary energy ratio for part load at indoor temperature 20 °C and outdoor temperature T _j / Coefficiente di prestazione dichiarato o indice di energia primaria per carico parziale, con temperatura interna pari a 20 °C e temperatura esterna T _j			
T _j = - 7 °C	<i>P_{djh}</i>	aj	kW	T _j = - 7 °C	<i>COP_d</i>	at	-
T _j = + 2 °C	<i>P_{djh}</i>	ak	kW	T _j = + 2 °C	<i>COP_d</i>	au	-
T _j = + 7 °C	<i>P_{djh}</i>	al	kW	T _j = + 7 °C	<i>COP_d</i>	av	-
T _j = + 12 °C	<i>P_{djh}</i>	am	kW	T _j = + 12 °C	<i>COP_d</i>	aw	-
T _j = bivalent temperature / Temperatura bivalente	<i>P_{djh}</i>	an	kW	T _j = bivalent temperature / Temperatura bivalente	<i>COP_d</i>	ax	-
T _j = operation limit temperature / temperatura limite di esercizio	<i>P_{djh}</i>	ao	kW	T _j = operation limit temperature / temperatura limite di esercizio	<i>COP_d</i>	ay	-
For air-to-water heat pumps: T _j = - 15 °C (if TOL < - 20 °C) / Per le pompe di calore aria/ acqua: T _j = - 15 °C (se TOL < - 20 °C)	<i>P_{djh}</i>	ap	kW	For air-to-water heat pumps: T _j = - 15 °C (if TOL < - 20 °C) / Per le pompe di calore aria/ acqua: T _j = - 15 °C (se TOL < - 20 °C)	<i>COP_d</i>	az	-
Bivalent temperature / Temperatura bivalente	<i>T_{biv}</i>	aq	°C	For air-to-water heat pumps: Operation limit temperature / Per le pompe di calore aria/ acqua: temperatura limite di esercizio	<i>TOL</i>	ba	°C
Cycling interval capacity for heating / Ciclicità degli intervalli di capacità per il riscaldamento	<i>P_{cych}</i>	ar	kW	Cycling interval efficiency / Efficienza della ciclicità degli intervalli	<i>COP_{cych}</i>	bb	-
Degradation co-efficient (**)/ Coefficiente di degradazione (**)	<i>C_{dh}</i>	as	-	Heating water operating limit temperature / Temperatura limite di esercizio di riscaldamento dell'acqua	<i>WTOL</i>	bc	-

Power consumption in modes other than active mode / Consumo energetico in modi diversi dal modo attivo				Supplementary heater / Riscaldatore supplementare			
Off mode / Modo spento	<i>POFF</i>	bd	kW	Rated heat output (*) / Potenza termica nominale (*)	<i>P_{sup}</i>	bh	kW
Thermostat-off mode / Modo termostato spento	<i>PTO</i>	be	kW				
Standby mode / Modo stand-by	<i>PSB</i>	bf	kW	Type of energy input / Tipo di alimentazione energetica	bi		
Crankcase heater mode / Modo riscaldamento del carter	<i>PCK</i>	bg	kW				
Other items / Altri elementi							
Capacity control / Controllo della capacità	bj		For air-to-water heat pumps: Rated air flow rate, outdoors / Per le pompe di calore aria/ acqua: portata d'aria, all'esterno		-	bm	m ³ /h
Sound power level, indoors/outdoors / Livello della potenza sonora, all'interno/all'esterno	<i>LWA</i>	bk	dB(A)	For water-/brine-to-water heat pumps: Rated brine or water flow rate, outdoor heat exchanger / Per le pompe di calore acqua/acqua e salamoia/acqua: flusso di salamoia o acqua nominale, scambiatore di calore all'esterno	-	bn	m ³ /h
Annual energy consumption / Consumo energetico annuo	<i>QHE</i>	bl	kWh				
For heat pump combination heater: / Per gli apparecchi di riscaldamento misti a pompa di calore:							
Declared load profile / Profilo di carico dichiarato	bo		Water heating energy efficiency / Efficienza energetica di riscaldamento dell'acqua		<i>η_{wh}</i>	bq	-
Daily electricity consumption / Consumo quotidiano di energia elettrica	<i>Qelec</i>	bp	kWh	Daily fuel consumption / Consumo quotidiano di combustibile	<i>Qfuel</i>	br	kWh
Annual electricity consumption / Consumo annuo di energia elettrica	<i>AEC</i>	bs	kWh	Annual fuel consumption / Consumo annuo di combustibile	<i>AFC</i>	bt	GJ
Contact details: / Recapiti:	CLIVET SPA - VIA CAMP LONC, 25 - Z.I. VILLAPAIERA - 32032 FELTRE (BL) - ITALY						
<p>(*) For heat pump space heaters and heat pump combination heaters, the rated heat output Prated is equal to the design load for heating Pdesignh, and the rated heat output of a supplementary heater Psup is equal to the supplementary capacity for heating sup(Tj).</p> <p>(**) If Cdh is not determined by measurement then the default degradation coefficient is Cdh = 0,9. /</p> <p>(*) Per gli apparecchi a pompa di calore per il riscaldamento d'ambiente e gli apparecchi di riscaldamento misti a pompa di calore, la potenza termica nominale Pnominale è pari al carico teorico per il riscaldamento Pdesignh e la potenza termica nominale di un riscaldatore supplementare Psup è pari alla capacità supplementare di riscaldamento sup(Tj).</p> <p>(**) Se Cdh non è determinato mediante misurazione, il coefficiente di degradazione è Cdh = 0,9.</p>							

Modello scheda prodotto / Product card model

Product fiche: combination heaters Scheda prodotto: apparecchi di riscaldamento misti			
SERIES / Serie	<i>ca</i>		
Model / Modello	1	-	<i>cb</i>
Size / Grandezza	2	-	<i>cc</i>
Medium-temperature application / Applicazione a media temperatura	3	°C	<i>cd</i>
Low-temperature application / Applicazione a bassa temperatura	4	°C	<i>ce</i>
DHW profile / Profilo ACS	5	-	<i>cf</i>
Medium-temperature class / Classe a media temperatura	6	-	<i>cg</i>
Low-temperature class / Classe a bassa temperatura	7	-	<i>ch</i>
DHW class / Classe ACS	8	-	<i>ci</i>
Ptn	9	kW	<i>cj</i>
Qhe_ambiente	10	kWh	<i>ck</i>
Qhe_acs	11	kWh	<i>cl</i>
η_s	12	%	<i>cm</i>
η_{s_wh}	13	%	<i>cn</i>
LwA_in	14	dB	<i>co</i>
FOM	15	-	<i>cp</i>
Precautions / Precauzioni	16	See installation and operating manual / Vedi manuale di uso e manutenzione	
P th_colder	17	kW	<i>cq</i>
P th_warmer	18	kW	<i>cr</i>
Q HE_colder	19	kWh	<i>cs</i>
Q HE_warmer	20	kWh	<i>ct</i>
Q HE_colder_wh	21	kWh	<i>cu</i>
Q HE_warmer_wh	22	kWh	<i>cv</i>
η_{s_colder}	23	%	<i>cw</i>
η_{s_warmer}	24	%	<i>cx</i>
$\eta_{s_colder_wh}$	25	%	<i>cy</i>
$\eta_{s_warmer_wh}$	26	%	<i>cz</i>
LwA_out	27	dB	<i>da</i>

Product fiche: temperature control /
 Scheda prodotto: dispositivi di controllo della temperatura

SERIES / Serie	<i>ca</i>		
Model / Modello	1	-	<i>cb</i>
Size / Grandezza	2	-	<i>cc</i>
Device class	3	-	<i>db</i>
η_s	4	%	<i>dc</i>

Product fiche: packages of combination heater, temperature control and solar device /
 Scheda prodotto: insiemi di apparecchi di riscaldamento misti, dispositivi di controllo della temperatura e dispositivi solari

I	1	%	<i>cm</i>
II	2	-	<i>dd</i>
III	3	-	<i>de</i>
IV	4	-	<i>df</i>
V	5	-	<i>dg</i>
VI	6	-	<i>dh</i>
Control class T / Classe controllo T	7	%	<i>db</i>
$\eta_{s_caldaia}$	8	%	<i>di</i>
Collector / Collettore	9	m ²	<i>dj</i>
V serbatoio	10	m ³	<i>dk</i>
$\eta_{collettore}$	11	%	<i>dl</i>
Storage Tank Class / Classe serbatoio	12	-	<i>dm</i>
Energy Efficiency / Efficienza energetica	13	%	<i>dn</i>
Energy Efficiency C / Efficienza energetica C	14	%	<i>do</i>
Energy Efficiency W / Efficienza energetica W	15	%	<i>dp</i>
I	16	%	<i>cn</i>
II	17	-	<i>dq</i>
III	18	-	<i>dr</i>
Load Profile / Profilo di carico	19	-	<i>cf</i>
η_{s_wh}	20	%	<i>cn</i>
$\eta_{s_wh_colder}$	21	%	<i>cy</i>
$\eta_{s_wh_warmer}$	22	%	<i>cz</i>

Media temperatura / medium-temperature

ID	Description	Symbol	2.1 - 190L SQKN-YEE 1 TC MISAN-YEE 1 S 2.1 (190L)	2.1 - 250L SQKN-YEE 1 TC MISAN-YEE 1 S 2.1 (250L)	3.1 - 190L SQKN-YEE 1 TC MISAN-YEE 1 S 3.1 (190L)	3.1 - 250L SQKN-YEE 1 TC MISAN-YEE 1 S 3.1 (250L)	4.1 - 190L SQKN-YEE 1 TC MISAN-YEE 1 S 4.1 (190L)	4.1 - 250L SQKN-YEE 1 TC MISAN-YEE 1 S 4.1 (250L)
aa	Model(s) / Modelli:	-						
ab	Air-to-water heat pump: / Pompa di calore aria/acqua:	-	YES	YES	YES	YES	YES	YES
ac	Water-to-water heat pump: / Pompa di calore acqua/acqua:	-	NO	NO	NO	NO	NO	NO
ad	Brine-to-water heat pump: / Pompa di calore salamoia/acqua:	-	NO	NO	NO	NO	NO	NO
ae	Low-temperature heat pump: / Pompa di calore a bassa temperatura:	-	NO	NO	NO	NO	NO	NO
af	Equipped with a supplementary heater: / Con riscaldatore supplementare:	-	NO	NO	NO	NO	NO	NO
ag	Heat pump combination heater: / Apparecchio misto a pompa di calore:	-	YES	YES	YES	YES	YES	YES
ah	Rated heat output (*) / Potenza termica nominale (*)	Prated	4	4	6	6	7	7
ai	Seasonal space heating energy efficiency / Efficienza energetica stagionale del riscaldamento d'ambiente	ηs	130	130	139	139	146	146
aj	Tj = - 7 °C	Pdh	3,61	3,61	4,97	4,97	6,09	6,09
ak	Tj = + 2 °C	Pdh	2,16	2,16	3,02	3,02	3,94	3,94
al	Tj = + 7 °C	Pdh	1,54	1,54	2,00	2,00	2,52	2,52
am	Tj = + 12 °C	Pdh	1,29	1,29	1,30	1,30	1,72	1,72
an	Tj = bivalent temperature / Temperatura bivalente	Pdh	3,61	3,61	4,97	4,97	6,09	6,09
ao	Tj = operation limit temperature / Temperatura limite di esercizio	Pdh	3,91	3,91	5,27	5,27	4,97	4,97
ap	For air-to-water heat pumps: Tj = - 15 °C (if TOL < - 20 °C) / Per le pompe di calore aria/ acqua: Tj = - 15 °C (se TOL < - 20 °C)	Pdh	-	-	-	-	-	-
aq	Bivalent temperature / Temperatura bivalente	Tbiv	-7	-7	-7	-7	-7	-7
ar	Cycling interval capacity for heating / Ciclicità degli intervalli di capacità per il riscaldamento	Pcych	-	-	-	-	-	-
as	Degradation co-efficient (***) / Coefficiente di degradazione (***)	Cdh	0,9	0,9	0,9	0,9	0,9	0,9
at	Tj = - 7 °C	COPd	2,02	2,02	2,12	2,12	2,27	2,27
au	Tj = + 2 °C	COPd	3,21	3,21	3,41	3,41	3,56	3,56
av	Tj = + 7 °C	COPd	4,43	4,43	4,82	4,82	4,70	4,70
aw	Tj = + 12 °C	COPd	6,20	6,20	6,32	6,32	9,71	9,71
ax	Tj = bivalent temperature / Temperatura bivalente	COPd	2,02	2,02	2,12	2,12	2,27	2,27
ay	Tj = operation limit temperature / Temperatura limite di esercizio	COPd	1,68	1,68	1,64	1,64	1,88	1,88
az	For air-to-water heat pumps: Tj = - 15 °C (if TOL < - 20 °C) / Per le pompe di calore aria/ acqua: Tj = - 15 °C (se TOL < - 20 °C)	COPd	-	-	-	-	-	-
ba	For air-to-water heat pumps: Operation limit temperature / Per le pompe di calore aria/ acqua: temperatura limite di esercizio	TOL	-10	-10	-10	-10	-10	-10
bb	Cycling interval efficiency / Efficienza della ciclicità degli intervalli	COPcych	-	-	-	-	-	-
bc	Heating water operating limit temperature / Temperatura limite di esercizio di riscaldamento dell'acqua	WTOL	65	65	65	65	65	65
bd	Off mode / Modo spento	POFF	0,015	0,015	0,015	0,015	0,015	0,015
be	Thermostat-off mode / Modo termostato spento	PTO	0,015	0,015	0,015	0,015	0,015	0,015
bf	Standby mode / Modo stand-by	PSB	0,015	0,015	0,015	0,015	0,015	0,015
bg	Crankcase heater mode / Modo riscaldamento del carter	PCK	0,000	0,000	0,000	0,000	0,000	0,000
bh	Rated heat output (*) / Potenza termica nominale (*)	Psup	0,2	0,2	0,4	0,4	1,9	1,9
bi	Type of energy input / Tipo di alimentazione energetica		-	-	-	-	-	-
bj	Capacity control / Controllo della capacità		Variable / Variabile	Variable / Variabile	Variable / Variabile	Variable / Variabile	Variable / Variabile	Variable / Variabile
bl	Sound power level, indoors/outdoors / Livello della potenza sonora, all'interno/all'esterno	LWA	41/55	41/55	41/57	41/57	41/58	41/58
bl	Annual energy consumption / Consumo energetico annuale	kWh	2542	2542	3283	3283	3824	3824
bm	For air-to-water heat pumps: Rated air flow rate, outdoors / Per le pompe di calore aria/ acqua: portata d'aria, all'esterno		2750	2750	3000	3000	4750	4750
bn	For water-/brine-to-water heat pumps: Rated brine or water flow rate, outdoor heat exchanger / Per le pompe di calore acqua/acqua e salamoia/acqua: flusso di salamoia o acqua nominale, scambiatore di calore all'esterno		-	-	-	-	-	-
bo	Declared load profile / Profilo di carico dichiarato		L	XL	L	XL	L	XL
bp	Daily electricity consumption / Consumo quotidiano di energia elettrica	Qelec	4,128	6,641	4,128	6,641	4,272	6,366
bq	Water heating energy efficiency / Efficienza energetica di riscaldamento dell'acqua	ηwh	120	123	120	123	116	79
br	Daily fuel consumption / Consumo quotidiano di combustibile	Qfuel	-	-	-	-	-	-

ID	Description	Symbol	5.1 - 190L	5.1 - 250L	6.1 - 250L	7.1 - 250L	8.1 - 250L
			SQKN-YEE 1 TC MiSAN-YEE 1 S 5.1 (190L)	SQKN-YEE 1 TC MiSAN-YEE 1 S 5.1 (250L)	SQKN-YEE 1 TC MiSAN-YEE 1 S 6.1 (250L)	SQKN-YEE 1 TC MiSAN-YEE 1 S 7.1 (250L)	SQKN-YEE 1 TC MiSAN-YEE 1 S 8.1 (250L)
aa	Model(s) / Modelli:	-					
ab	Air-to-water heat pump: / Pompa di calore aria/acqua:	-	YES	YES	YES	YES	YES
ac	Water-to-water heat pump: / Pompa di calore acqua/acqua:	-	NO	NO	NO	NO	NO
ad	Brine-to-water heat pump: / Pompa di calore salamoia/acqua:	-	NO	NO	NO	NO	NO
ae	Low-temperature heat pump: / Pompa di calore a bassa temperatura:	-	NO	NO	NO	NO	NO
af	Equipped with a supplementary heater: / Con riscaldatore supplementare:	-	NO	NO	NO	NO	NO
ag	Heat pump combination heater: / Apparecchio misto a pompa di calore:	-	YES	YES	YES	YES	YES
ah	Rated heat output (*) / Potenza termica nominale (*)	Prated	9	9	12	13	13
ai	Seasonal space heating energy efficiency / Efficienza energetica stagionale del riscaldamento d'ambiente	η_s	146	146	140	138	136
aj	Tj = - 7 °C	Pdh	7,58	7,58	10,35	11,12	11,79
ak	Tj = + 2 °C	Pdh	4,44	4,44	6,62	6,82	7,05
al	Tj = + 7 °C	Pdh	2,92	2,92	4,45	4,73	4,73
am	Tj = + 12 °C	Pdh	1,74	1,74	3,04	3,03	3,03
an	Tj = bivalent temperature / Temperatura bivalente	Pdh	7,58	7,58	10,35	11,12	11,79
ao	Tj = operation limit temperature / Temperatura limite di esercizio	Pdh	5,46	5,46	9,59	9,88	10,67
ap	For air-to-water heat pumps: Tj = - 15 °C (if TOL < - 20 °C) / Per le pompe di calore aria/ acqua: Tj = - 15 °C (se TOL < - 20 °C)	Pdh	-	-	-	-	-
aq	Bivalent temperature / Temperatura bivalente	Tbiv	-7	-7	-7	-7	-7
ar	Cycling interval capacity for heating / Ciclicità degli intervalli di capacità per il riscaldamento	Pcych	-	-	-	-	-
as	Degradation co-efficient (***) / Coefficiente di degradazione (***)	Cdh	0,9	0,9	0,9	0,9	0,9
at	Tj = - 7 °C	COPd	2,02	2,02	2,05	2,06	2,04
au	Tj = + 2 °C	COPd	3,63	3,63	3,51	3,41	3,34
av	Tj = + 7 °C	COPd	4,95	4,95	4,77	4,85	4,85
aw	Tj = + 12 °C	COPd	9,87	9,87	6,43	6,43	6,43
ax	Tj = bivalent temperature / Temperatura bivalente	COPd	2,02	2,02	2,05	2,06	2,04
ay	Tj = operation limit temperature / Temperatura limite di esercizio	COPd	1,87	1,87	1,85	1,86	1,84
az	For air-to-water heat pumps: Tj = - 15 °C (if TOL < - 20 °C) / Per le pompe di calore aria/ acqua: Tj = - 15 °C (se TOL < - 20 °C)	COPd	-	-	-	-	-
ba	For air-to-water heat pumps: Operation limit temperature / Per le pompe di calore aria/ acqua: temperatura limite di esercizio	TOL	-10	-10	-10	-10	-10
bb	Cycling interval efficiency / Efficienza della ciclicità degli intervalli	COPcych	-	-	-	-	-
bc	Heating water operating limit temperature / Temperatura limite di esercizio di riscaldamento dell'acqua	WTOL	65	65	65	65	65
bd	Off mode / Modo spento	POFF	0,015	0,015	0,015	0,015	0,015
be	Thermostat-off mode / Modo termostato spento	PTO	0,015	0,015	0,015	0,015	0,015
bf	Standby mode / Modo stand-by	PSB	0,015	0,015	0,015	0,015	0,015
bg	Crankcase heater mode / Modo riscaldamento del carter	PCK	0,000	0,000	0,000	0,000	0,000
bh	Rated heat output (*) / Potenza termica nominale (*)	Psup	3,1	3,1	2,1	2,7	2,7
bi	Type of energy input / Tipo di alimentazione energetica		-	-	-	-	-
bj	Capacity control / Controllo della capacità		Variable /Variabile	Variable /Variabile	Variable /Variabile	Variable /Variabile	Variable /Variabile
bl	Sound power level, indoors/outdoors / Livello della potenza sonora, all'interno/all'esterno	LWA	41/60	41/60	41/63	41/64	41/66
bl	Annual energy consumption / Consumo energetico annuale	kWh	4749	4749	6793	7380	7915
bm	For air-to-water heat pumps: Rated air flow rate, outdoors / Per le pompe di calore aria/ acqua: portata d'aria, all'esterno		5000	5000	6000	6250	6500
bn	For water-/brine-to-water heat pumps: Rated brine or water flow rate, outdoor heat exchanger / Per le pompe di calore acqua/acqua e salamoia/acqua: flusso di salamoia o acqua nominale, scambiatore di calore all'esterno		-	-	-	-	-
bo	Declared load profile / Profilo di carico dichiarato		L	XL	XL	XL	XL
bp	Daily electricity consumption / Consumo quotidiano di energia elettrica	Qelec	4,272	6,366	6,466	6,466	6,466
bq	Water heating energy efficiency / Efficienza energetica di riscaldamento dell'acqua	η_{wh}	116	125	124	124	124
br	Daily fuel consumption / Consumo quotidiano di combustibile	Qfuel	-	-	-	-	-
br	Annual electricity consumption / Consumo energetico annuale		880	1345	1354	1354	1354

ID	Description	Symbol	2.1 - 190L	2.1 - 250L	3.1 - 190L	3.1 - 250L	4.1 - 190L	4.1 - 250L
ca	SERIES / Serie	-	SPHERA EVO 2.0	SPHERA EVO 2.0	SPHERA EVO 2.0	SPHERA EVO 2.0	SPHERA EVO 2.0	SPHERA EVO 2.0
cb	Model / Modello	-	SQKN-YEE 1 TC MISAN-YEE 1 S	SQKN-YEE 1 TC MISAN-YEE 1 S	SQKN-YEE 1 TC MISAN-YEE 1 S	SQKN-YEE 1 TC MISAN-YEE 1 S	SQKN-YEE 1 TC MISAN-YEE 1 S	SQKN-YEE 1 TC MISAN-YEE 1 S
cc	Size / Grandezza	-	2.1 - 190L	2.1 - 250L	3.1 - 190L	3.1 - 250L	4.1 - 190L	4.1 - 250L
cd	Medium-temperature application / Applicazione a media temperatura	°C	55	55	55	55	55	55
ce	Low-temperature application / Applicazione a bassa temperatura	°C	35	35	35	35	35	35
cf	DHW profile / Profilo ACS	-	L	XL	L	XL	L	XL
cg	Medium-temperature class / Classe a media temperatura	-	A++	A++	A++	A++	A++	A++
ch	Low-temperature class / Classe a bassa temperatura	-	A+++	A+++	A+++	A+++	A+++	A+++
ci	DHW class / Classe ACS	-	A+	A+	A+	A+	A+	A+
cj	Ptn	kW	4	4	6	6	7	7
ck	Qhe_ambiente	kWh	2542	2542	3283	3283	3824	3824
cl	Qhe_acs	kWh	852	1391	852	1391	880	1345
cm	η_s	%	130	130	139	139	146	146
cn	η_{s_wh}	%	120	123	120	123	116	125
co	LwA_in	dB(A)	41	41	41	41	41	41
cp	FOM	-	-	-	-	-	-	-
cq	P th_colder	kW	4	4	5	5	7	7
cr	P th_warmer	kW	5	5	7	7	9	9
cs	Q HE_colder	kWh	3164	3164	4087	4087	4761	4761
ct	Q HE_warmer	kWh	1719	1719	2217	2217	2581	2581
cu	Q HE_colder_wh	kWh	940	1566	940	1566	1191	1566
cv	Q HE_warmer_wh	kWh	794	1140	794	1140	753	1214
cw	η_{s_colder}	%	118	118	126	126	132	132
cx	η_{s_warmer}	%	163	163	174	174	183	183
cy	$\eta_{s_colder_wh}$	%	109	107	109	107	86	107
cz	$\eta_{s_warmer_wh}$	%	129	147	129	147	136	138
da	LwA_out	dB(A)	55	55	57	57	58	58
db	Device class	-	VIII	VIII	VIII	VIII	VIII	VIII
dc	η_s	%	5	5	5	5	5	5
dd	II	-	-	-	-	-	-	-
de	III	-	7	7	5	5	4	4
df	IV	-	3	3	2	2	2	2
dg	V	-	12	12	13	13	14	14
dh	VI	-	33	33	35	35	37	37
di	$\eta_{s_caldaia}$	%	-	-	-	-	-	-
dj	Collector / Collettore	m2	-	-	-	-	-	-
dk	V serbatoio	m3	-	-	-	-	-	-
dl	η collettore	%	-	-	-	-	-	-
dm	Storage Tank Class / Classe serbatoio	-	-	-	-	-	-	-
dn	Energy Efficiency / Efficienza energetica	%	135	135	144	144	151	151
do	Energy Efficiency C / Efficienza energetica C	%	123	123	131	131	137	137
dp	Energy Efficiency W / Efficienza energetica W	%	168	168	179	179	188	188
dq	II	-	-	-	-	-	-	-
dr	III	-	-	-	-	-	-	-

ID	Description	Symbol	5.1 - 190L	5.1 - 250L	6.1 - 250L	7.1 - 250L	8.1 - 250L
ca	SERIES / Serie	-	SPHERA EVO 2.0	SPHERA EVO 2.0	SPHERA EVO 2.0	SPHERA EVO 2.0	SPHERA EVO 2.0
cb	Model / Modello	-	SQKN-YEE 1 TC MISAN-YEE 1 S	SQKN-YEE 1 TC MISAN-YEE 1 S	SQKN-YEE 1 TC MISAN-YEE 1 S	SQKN-YEE 1 TC MISAN-YEE 1 S	SQKN-YEE 1 TC MISAN-YEE 1 S
cc	Size / Grandezza	-	5.1 - 190L	5.1 - 250L	6.1 - 250L	7.1 - 250L	8.1 - 250L
cd	Medium-temperature application / Applicazione a media temperatura	°C	55	55	55	55	55
ce	Low-temperature application / Applicazione a bassa temperatura	°C	35	35	35	35	35
cf	DHW profile / Profilo ACS	-	L	XL	XL	XL	XL
cg	Medium-temperature class / Classe a media temperatura	-	A++	A++	A++	A++	A++
ch	Low-temperature class / Classe a bassa temperatura	-	A+++	A+++	A+++	A+++	A+++
ci	DHW class / Classe ACS	-	A+	A+	A+	A+	A+
cj	Ptn	kW	9	9	12	13	13
ck	Qhe_ambiente	kWh	4749	4749	6793	7380	7915
cl	Qhe_acs	kWh	880	1345	1354	1354	1354
cm	η_s	%	146	146	140	138	136
cn	η_{s_wh}	%	116	125	124	124	124
co	LwA_in	dB(A)	41	41	41	41	41
cp	FOM	-	-	-	-	-	-
cq	P th_colder	kW	8	8	11	12	13
cr	P th_warmer	kW	11	11	15	16	17
cs	Q HE_colder	kWh	5914	5914	8459	9191	9857
ct	Q HE_warmer	kWh	3204	3204	4578	4973	5333
cu	Q HE_colder_wh	kWh	1191	1566	1675	1675	1675
cv	Q HE_warmer_wh	kWh	753	1214	1171	1171	1171
cw	η_{s_colder}	%	133	133	127	125	124
cx	η_{s_warmer}	%	184	184	175	173	171
cy	$\eta_{s_colder_wh}$	%	86	107	100	100	100
cz	$\eta_{s_warmer_wh}$	%	136	138	143	143	143
da	LwA_out	dB(A)	60	60	63	64	66
db	Device class	-	VIII	VIII	VIII	VIII	VIII
dc	η_s	%	5	5	5	5	5
dd	II	-	-	-	-	-	-
de	III	-	3	3	2	2	2
df	IV	-	1	1	1	1	1
dg	V	-	13	13	13	13	12
dh	VI	-	38	38	35	35	35
di	$\eta_{s_caldaia}$	%	-	-	-	-	-
dj	Collector / Collettore	m2	-	-	-	-	-
dk	V serbatoio	m3	-	-	-	-	-
dl	η collettore	%	-	-	-	-	-
dm	Storage Tank Class / Classe serbatoio	-	-	-	-	-	-
dn	Energy Efficiency / Efficienza energetica	%	151	151	145	143	141
do	Energy Efficiency C / Efficienza energetica C	%	138	138	132	130	129
dp	Energy Efficiency W / Efficienza energetica W	%	189	189	180	178	176
dq	II	-	-	-	-	-	-
dr	III	-	-	-	-	-	-

Bassa temperatura / low-temperature

ID	Description	Symbol	2.1 - 190L SQKN-YEE 1 TC MISAN-YEE 1 S 2.1 (190L)	2.1 - 250L SQKN-YEE 1 TC MISAN-YEE 1 S 2.1 (250L)	3.1 - 190L SQKN-YEE 1 TC MISAN-YEE 1 S 3.1 (190L)	3.1 - 250L SQKN-YEE 1 TC MISAN-YEE 1 S 3.1 (250L)	4.1 - 190L SQKN-YEE 1 TC MISAN-YEE 1 S 4.1 (190L)	4.1 - 250L SQKN-YEE 1 TC MISAN-YEE 1 S 4.1 (250L)
aa	Model(s) / Modelli:	-						
ab	Air-to-water heat pump: / Pompa di calore aria/acqua:	-	YES	YES	YES	YES	YES	YES
ac	Water-to-water heat pump: / Pompa di calore acqua/acqua:	-	NO	NO	NO	NO	NO	NO
ad	Brine-to-water heat pump: / Pompa di calore salamoia/acqua:	-	NO	NO	NO	NO	NO	NO
ae	Low-temperature heat pump: / Pompa di calore a bassa temperatura:	-	YES	YES	YES	YES	YES	YES
af	Equipped with a supplementary heater: / Con riscaldatore supplementare:	-	NO	NO	NO	NO	NO	NO
ag	Heat pump combination heater: / Apparecchio misto a pompa di calore:	-	YES	YES	YES	YES	YES	YES
ah	Rated heat output (*) / Potenza termica nominale (*)	Prated	5	5	6	6	8	8
ai	Seasonal space heating energy efficiency / Efficienza energetica stagionale del riscaldamento d'ambiente	η_s	202	202	203	203	210	210
aj	Tj = -7 °C	Pdh	4,74	4,74	5,51	5,51	7,15	7,15
ak	Tj = +2 °C	Pdh	3,05	3,05	3,30	3,30	4,65	4,65
al	Tj = +7 °C	Pdh	1,99	1,99	2,24	2,24	2,91	2,91
am	Tj = +12 °C	Pdh	1,45	1,45	1,45	1,45	1,85	1,85
an	Tj = bivalent temperature / Temperatura bivalente	Pdh	4,74	4,74	5,51	5,51	7,15	7,15
ao	Tj = operation limit temperature / Temperatura limite di esercizio	Pdh	5,21	5,21	5,80	5,80	6,42	6,42
ap	For air-to-water heat pumps: Tj = -15 °C (if TOL < -20 °C) / Per le pompe di calore aria/ acqua: Tj = -15 °C (se TOL < -20 °C)	Pdh	-	-	-	-	-	-
aq	Bivalent temperature / Temperatura bivalente	Tbiv	-7	-7	-7	-7	-7	-7
ar	Cycling interval capacity for heating / Ciclicità degli intervalli di capacità per il riscaldamento	Pcych	-	-	-	-	-	-
as	Degradation co-efficient (**) / Coefficiente di degradazione (**)	Cdh	0,9	0,9	0,9	0,9	0,9	0,9
at	Tj = -7 °C	COPd	3,15	3,15	3,13	3,13	3,30	3,30
au	Tj = +2 °C	COPd	4,96	4,96	4,91	4,91	5,17	5,17
av	Tj = +7 °C	COPd	6,81	6,81	7,11	7,11	7,08	7,08
aw	Tj = +12 °C	COPd	8,94	8,94	8,94	8,94	9,46	9,46
ax	Tj = bivalent temperature / Temperatura bivalente	COPd	3,15	3,15	3,13	3,13	3,30	3,30
ay	Tj = operation limit temperature / Temperatura limite di esercizio	COPd	2,86	2,86	2,70	2,70	3,06	3,06
az	For air-to-water heat pumps: Tj = -15 °C (if TOL < -20 °C) / Per le pompe di calore aria/ acqua: Tj = -15 °C (se TOL < -20 °C)	COPd	-	-	-	-	-	-
ba	For air-to-water heat pumps: Operation limit temperature / Per le pompe di calore aria/ acqua: temperatura limite di esercizio	TOL	-10	-10	-10	-10	-10	-10
bb	Cycling interval efficiency / Efficienza della ciclicità degli intervalli	COPcych	-	-	-	-	-	-
bc	Heating water operating limit temperature / Temperatura limite di esercizio di riscaldamento dell'acqua	WTOL	65	65	65	65	65	65
bd	Off mode / Modo spento	POFF	0,015	0,015	0,015	0,015	0,015	0,015
be	Thermostat-off mode / Modo termostato spento	PTO	0,015	0,015	0,015	0,015	0,015	0,015
bf	Standby mode / Modo stand-by	PSB	0,015	0,015	0,015	0,015	0,015	0,015
bg	Crankcase heater mode / Modo riscaldamento del carter	PCK	0,000	0,000	0,000	0,000	0,000	0,000
bh	Rated heat output (*) / Potenza termica nominale (*)	Psup	0,2	0,2	0,4	0,4	1,9	1,9
bi	Type of energy input / Tipo di alimentazione energetica		-	-	-	-	-	-
bj	Capacity control / Controllo della capacità		Variable / Variabile	Variabile / Variabile	Variable / Variabile	Variabile / Variabile	Variabile / Variabile	Variabile / Variabile
bl	Sound power level, indoors/outdoors / Livello della potenza sonora, all'interno/all'esterno	LWA	41/55	41/55	41/57	41/57	41/58	41/58
bl	Annual energy consumption / Consumo energetico annuale	kWh	2161	2161	2502	2502	3141	3141
bm	For air-to-water heat pumps: Rated air flow rate, outdoors / Per le pompe di calore aria/ acqua: portata d'aria, all'esterno		2750	2750	3000	3000	4750	4750
bn	For water-/brine-to-water heat pumps: Rated brine or water flow rate, outdoor heat exchanger / Per le pompe di calore acqua/acqua e salamoia/acqua: flusso di salamoia o acqua nominale, scambiatore di calore all'esterno		-	-	-	-	-	-
bo	Declared load profile / Profilo di carico dichiarato		L	XL	L	XL	L	XL
bp	Daily electricity consumption / Consumo quotidiano di energia elettrica	Qelec	4,128	6,641	4,128	6,641	4,272	6,366
bq	Water heating energy efficiency / Efficienza energetica di riscaldamento dell'acqua	η_{wh}	120	123	120	123	116	125
br	Daily fuel consumption / Consumo quotidiano di combustibile	Qfuel	-	-	-	-	-	-
	Annual electricity consumption / Consumo annuo di energia		852	1391	852	1391	880	1345

ID	Description	Symbol	5.1 - 190L	5.1 - 250L	6.1 - 250L	7.1 - 250L	8.1 - 250L
			SQKN-YEE 1 TC MISAN-YEE 1 S 5.1 (190L)	SQKN-YEE 1 TC MISAN-YEE 1 S 5.1 (250L)	SQKN-YEE 1 TC MISAN-YEE 1 S 6.1 (250L)	SQKN-YEE 1 TC MISAN-YEE 1 S 7.1 (250L)	SQKN-YEE 1 TC MISAN-YEE 1 S 8.1 (250L)
aa	Model(s) / Modelli:	-					
ab	Air-to-water heat pump: / Pompa di calore aria/acqua:	-	YES	YES	YES	YES	YES
ac	Water-to-water heat pump: / Pompa di calore acqua/acqua:	-	NO	NO	NO	NO	NO
ad	Brine-to-water heat pump: / Pompa di calore salamoia/acqua:	-	NO	NO	NO	NO	NO
ae	Low-temperature heat pump: / Pompa di calore a bassa temperatura:	-	YES	YES	YES	YES	YES
af	Equipped with a supplementary heater: / Con riscaldatore supplementare:	-	NO	NO	NO	NO	NO
ag	Heat pump combination heater: / Apparecchio misto a pompa di calore:	-	YES	YES	YES	YES	YES
ah	Rated heat output (*) / Potenza termica nominale (*)	Prated	10	10	12	14	16
ai	Seasonal space heating energy efficiency / Efficienza energetica stagionale del riscaldamento d'ambiente	ηs	208	208	197	193	193
aj	Tj = -7 °C	Pdh	8,45	8,45	10,69	12,33	13,82
ak	Tj = +2 °C	Pdh	5,23	5,23	6,57	7,97	8,55
al	Tj = +7 °C	Pdh	3,47	3,47	4,48	5,21	5,88
am	Tj = +12 °C	Pdh	1,96	1,96	3,67	3,67	3,67
an	Tj = bivalent temperature / Temperatura bivalente	Pdh	8,45	8,45	10,69	12,33	13,82
ao	Tj = operation limit temperature / Temperatura limite di esercizio	Pdh	7,38	7,38	10,95	11,90	12,64
ap	For air-to-water heat pumps: Tj = -15 °C (if TOL < -20 °C) / Per le pompe di calore aria/ acqua: Tj = -15 °C (se TOL < -20 °C)	Pdh	-	-	-	-	-
aq	Bivalent temperature / Temperatura bivalente	Tbiv	-7	-7	-7	-7	-7
ar	Cycling interval capacity for heating / Ciclicità degli intervalli di capacità per il riscaldamento	Pcych	-	-	-	-	-
as	Degradation co-efficient (**)/ Coefficiente di degradazione (**)	Cdh	0,9	0,9	0,9	0,9	0,9
at	Tj = -7 °C	COPd	3,18	3,18	3,07	2,87	2,86
au	Tj = +2 °C	COPd	5,03	5,03	4,68	4,62	4,59
av	Tj = +7 °C	COPd	7,33	7,33	6,90	7,07	7,13
aw	Tj = +12 °C	COPd	9,94	9,94	9,96	9,95	9,95
ax	Tj = bivalent temperature / Temperatura bivalente	COPd	3,18	3,18	3,07	2,87	2,86
ay	Tj = operation limit temperature / Temperatura limite di esercizio	COPd	2,97	2,97	2,79	2,69	2,59
az	For air-to-water heat pumps: Tj = -15 °C (if TOL < -20 °C) / Per le pompe di calore aria/ acqua: Tj = -15 °C (se TOL < -20 °C)	COPd	-	-	-	-	-
ba	For air-to-water heat pumps: Operation limit temperature / Per le pompe di calore aria/ acqua: temperatura limite di esercizio	TOL	-10	-10	-10	-10	-10
bb	Cycling interval efficiency / Efficienza della ciclicità degli intervalli	COPcych	-	-	-	-	-
bc	Heating water operating limit temperature / Temperatura limite di esercizio di riscaldamento dell'acqua	WTOL	65	65	65	65	65
bd	Off mode / Modo spento	POFF	0,015	0,015	0,015	0,015	0,015
be	Thermostat-off mode / Modo termostato spento	PTO	0,015	0,015	0,015	0,015	0,015
bf	Standby mode / Modo stand-by	PSB	0,015	0,015	0,015	0,015	0,015
bg	Crankcase heater mode / Modo riscaldamento del carter	PCK	0,000	0,000	0,000	0,000	0,000
bh	Rated heat output (*) / Potenza termica nominale (*)	Psup	3,1	3,1	2,1	2,7	2,7
bi	Type of energy input / Tipo di alimentazione energetica		-	-	-	-	-
bj	Capacity control / Controllo della capacità		Variable /Variabile	Variable /Variabile	Variable /Variabile	Variable /Variabile	Variable /Variabile
bl	Sound power level, indoors/outdoors / Livello della potenza sonora, all'interno/all'esterno	LWA	41/60	41/60	41/63	41/64	41/66
bl	Annual energy consumption / Consumo energetico annuale	kWh	3747	3747	4994	5868	6602
bm	For air-to-water heat pumps: Rated air flow rate, outdoors / Per le pompe di calore aria/ acqua: portata d'aria, all'esterno		5000	5000	6000	6250	6500
bn	For water-/brine-to-water heat pumps: Rated brine or water flow rate, outdoor heat exchanger / Per le pompe di calore acqua/acqua e salamoia/acqua: flusso di salamoia o acqua nominale, scambiatore di calore all'esterno		-	-	-	-	-
bo	Declared load profile / Profilo di carico dichiarato		L	XL	XL	XL	XL
bp	Daily electricity consumption / Consumo quotidiano di energia elettrica	Qelec	4,272	6,366	6,466	6,466	6,466
bq	Water heating energy efficiency / Efficienza energetica di riscaldamento dell'acqua	ηwh	116	125	124	124	124
br	Daily fuel consumption / Consumo quotidiano di combustibile	Qfuel	-	-	-	-	-
bs	Annual electricity consumption / Consumo annuo di energia elettrica	AEC	880	1345	1354	1354	1354
	Annual fuel consumption /						

ID	Description	Symbol	2.1 - 190L	2.1 - 250L	3.1 - 190L	3.1 - 250L	4.1 - 190L	4.1 - 250L
ca	SERIES / Serie	-	SPHERA EVO 2.0	SPHERA EVO 2.0	SPHERA EVO 2.0	SPHERA EVO 2.0	SPHERA EVO 2.0	SPHERA EVO 2.0
cb	Model / Modello	-	SQKN-YEE 1 TC MISAN-YEE 1 S	SQKN-YEE 1 TC MISAN-YEE 1 S	SQKN-YEE 1 TC MISAN-YEE 1 S	SQKN-YEE 1 TC MISAN-YEE 1 S	SQKN-YEE 1 TC MISAN-YEE 1 S	SQKN-YEE 1 TC MISAN-YEE 1 S
cc	Size / Grandezza	-	2.1 - 190L	2.1 - 250L	3.1 - 190L	3.1 - 250L	4.1 - 190L	4.1 - 250L
cd	Medium-temperature application / Applicazione a media temperatura	°C	55	55	55	55	55	55
ce	Low-temperature application / Applicazione a bassa temperatura	°C	35	35	35	35	35	35
cf	DHW profile / Profilo ACS	-	L	XL	L	XL	L	XL
cg	Medium-temperature class / Classe a media temperatura	-	A++	A++	A++	A++	A++	A++
ch	Low-temperature class / Classe a bassa temperatura	-	A+++	A+++	A+++	A+++	A+++	A+++
ci	DHW class / Classe ACS	-	A+	A+	A+	A+	A+	A+
cj	Ptn	kW	4	4	6	6	7	7
ck	Qhe_ambiente	kWh	2161	2161	2502	2502	3141	3141
cl	Qhe_acs	kWh	852	1391	852	1391	880	1345
cm	η_s	%	130	130	139	139	146	146
cn	η_{s_wh}	%	120	123	120	123	116	125
co	LwA_in	dB(A)	41	41	41	41	41	41
cp	FOM	-	-	-	-	-	-	-
cq	P th_colder	kW	5	5	6	6	8	8
cr	P th_warmer	kW	7	7	8	8	10	10
cs	Q HE_colder	kWh	3245	3245	3830	3830	4808	4808
ct	Q HE_warmer	kWh	1513	1513	1750	1750	2194	2194
cu	Q HE_colder_wh	kWh	940	1566	940	1566	1191	1566
cv	Q HE_warmer_wh	kWh	794	1140	794	1140	753	1214
cw	η_{s_colder}	%	163	163	164	164	169	169
cx	η_{s_warmer}	%	241	241	242	242	250	250
cy	$\eta_{s_colder_wh}$	%	109	107	109	107	86	107
cz	$\eta_{s_warmer_wh}$	%	129	147	129	147	136	138
da	LwA_out	dB(A)	55	55	57	57	58	58
db	Device class	-	VIII	VIII	VIII	VIII	VIII	VIII
dc	η_s	%	5	5	5	5	5	5
dd	II	-	-	-	-	-	-	-
de	III	-	6,55	6,55	4,76	4,76	3,88	3,88
df	IV	-	2,56	2,56	1,86	1,86	1,52	1,52
dg	V	-	12	12	13	13	14	14
dh	VI	-	33	33	35	35	37	37
di	$\eta_{s_caldaia}$	%	-	-	-	-	-	-
dj	Collector / Collettore	m2	-	-	-	-	-	-
dk	V serbatoio	m3	-	-	-	-	-	-
dl	$\eta_{collettore}$	%	-	-	-	-	-	-
dm	Storage Tank Class / Classe serbatoio	-	-	-	-	-	-	-
dn	Energy Efficiency / Efficienza energetica	%	135	135	144	144	151	151
do	Energy Efficiency C / Efficienza energetica C	%	123	123	131	131	137	137
dp	Energy Efficiency W / Efficienza energetica W	%	168	168	179	179	188	188
dq	II	-	-	-	-	-	-	-
dr	III	-	-	-	-	-	-	-

ID	Description	Symbol	5.1 - 190L	5.1 - 250L	6.1 - 250L	7.1 - 250L	8.1 - 250L
ca	SERIES / Serie	-	SPHERA EVO 2.0	SPHERA EVO 2.0	SPHERA EVO 2.0	SPHERA EVO 2.0	SPHERA EVO 2.0
cb	Model / Modello	-	SQKN-YEE 1 TC MISAN-YEE 1 S	SQKN-YEE 1 TC MISAN-YEE 1 S	SQKN-YEE 1 TC MISAN-YEE 1 S	SQKN-YEE 1 TC MISAN-YEE 1 S	SQKN-YEE 1 TC MISAN-YEE 1 S
cc	Size / Grandezza	-	5.1 - 190L	5.1 - 250L	6.1 - 250L	7.1 - 250L	8.1 - 250L
cd	Medium-temperature application / Applicazione a media temperatura	°C	55	55	55	55	55
ce	Low-temperature application / Applicazione a bassa temperatura	°C	35	35	35	35	35
cf	DHW profile / Profilo ACS	-	L	XL	XL	XL	XL
cg	Medium-temperature class / Classe a media temperatura	-	A++	A++	A++	A++	A++
ch	Low-temperature class / Classe a bassa temperatura	-	A+++	A+++	A+++	A+++	A+++
ci	DHW class / Classe ACS	-	A+	A+	A+	A+	A+
cj	Ptn	kW	9	9	12	13	13
ck	Qhe_ambiente	kWh	3747	3747	4994	5868	6602
cl	Qhe_acs	kWh	880	1345	1354	1354	1354
cm	ηs	%	146	146	140	138	136
cn	ηs_wh	%	116	125	124	124	124
co	LwA_in	dB(A)	41	41	41	41	41
cp	FOM	-	-	-	-	-	-
cq	P th_colder	kW	10	10	13	14	16
cr	P th_warmer	kW	12	12	15	16	17
cs	Q HE_colder	kWh	5737	5737	7648	8987	10111
ct	Q HE_warmer	kWh	2615	2615	3483	3670	3914
cu	Q HE_colder_wh	kWh	1191	1566	1675	1675	1675
cv	Q HE_warmer_wh	kWh	753	1214	1171	1171	1171
cw	η s_colder	%	168	168	159	156	155
cx	η s_warmer	%	248	248	235	231	230
cy	η s_colder_wh	%	86	107	100	100	100
cz	η s_warmer_wh	%	136	138	143	143	143
da	LwA_out	dB(A)	60	60	63	64	66
db	Device class	-	VIII	VIII	VIII	VIII	VIII
dc	η s	%	5	5	5	5	5
dd	II	-	-	-	-	-	-
de	III	-	3,12	3,12	2,28	2,13	2,01
df	IV	-	1,22	1,22	0,89	0,83	0,78
dg	V	-	13	13	13	13	12
dh	VI	-	38	38	35	35	35
di	η s_caldaia	%	-	-	-	-	-
dj	Collector / Collettore	m2	-	-	-	-	-
dk	V serbatoio	m3	-	-	-	-	-
dl	η collettore	%	-	-	-	-	-
dm	Storage Tank Class / Classe serbatoio	-	-	-	-	-	-
dn	Energy Efficiency / Efficienza energetica	%	151	151	145	143	141
do	Energy Efficiency C / Efficienza energetica C	%	138	138	132	130	129
dp	Energy Efficiency W / Efficienza energetica W	%	189	189	180	178	176
dq	II	-	-	-	-	-	-
dr	III	-	-	-	-	-	-

Dati tecnici per soluzione ibrida, sostituiscono i dati delle tabelle precedenti / Technical data for hybrid solution, replace the data in the previous tables

ID	Description	Symbol	24,2				24,4				34,4						
af	Equipped with a supplementary heater: / Con riscaldatore supplementare:	-	YES				YES				YES						
ah	Rated heat output (*) / Potenza termica nominale (*)	Prated	4	6	7	9	4	6	7	9	4	6	7	9	12	13	13
ai	Seasonal space heating energy efficiency / Efficienza energetica stagionale del riscaldamento	η_s	130	139	146	146	130	139	146	146	130	139	146	146	140	138	136
bh	Rated heat output (*) / Potenza termica nominale (*)	Psup	24				24				34						
bi	Type of energy input / Tipo di alimentazione energetica		Natural gas / Gas naturale				Natural gas / Gas naturale				Natural gas / Gas naturale						
cc	Size / Grandezza	-	2,1	3,1	4,1	5,1	2,1	3,1	4,1	5,1	2,1	3,1	4,1	5,1	6,1	7,1	8,1
dd	II	-	0,57	0,47	0,40	0,33	0,57	0,47	0,40	0,33	0,67	0,58	0,52	0,45	0,34	0,31	0,30
dg	V	-	12	13	14	13	12	13	14	13	12	13	14	13	13	13	12
dh	VI	-	33	35	37	38	33	35	37	38	33	35	37	38	35	35	35
di	η_s caldaia	%	94				94				94						
dn	Energy Efficiency / Efficienza energetica	%	114	123	130	134	114	123	130	134	111	118	124	128	129	129	129
do	Energy Efficiency C / Efficienza energetica C	%	102	110	116	121	102	110	116	121	99	105	110	115	117	116	116
dp	Energy Efficiency W / Efficienza energetica W	%	147	158	167	172	147	158	167	172	144	153	161	166	165	164	163

ENERG
енергия · ενεργεια



Y IJA
Y IJA
IE IA
IE IA

SQKN-YEE 1 TC + MiSAN-Y
EE 1 S 2.1 (190L)

Clivet S.p.A.

A⁺⁺
A⁺
A⁺⁺
A⁺

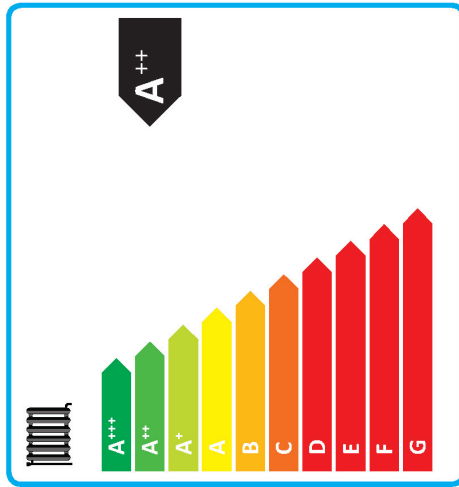

+
+
X
+

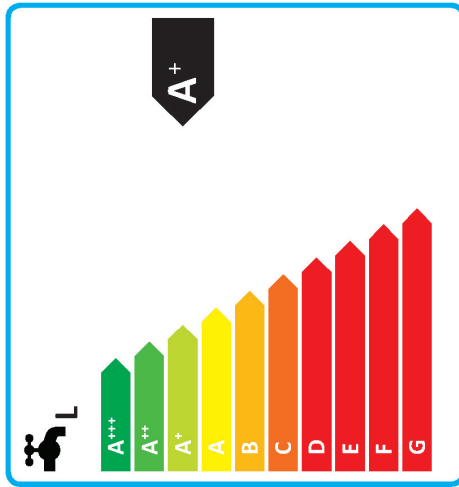

2015

811/2013



ENERG
енергия · ενεργεια

SQKN-YEE 1 TC + MiSAN
-YEE 1 S 2.1 (190L)

Clivet S.p.A.



41 dB
55 dB

04 kW
04 kW
05 kW



2019

811/2013



ENERG
енергия · ενεργεια

Y IJA
IE IA

Clivet S.p.A.

SQKN-YEE 1 TC + MiSAN-Y
EE 1 S 2.1 (190L)

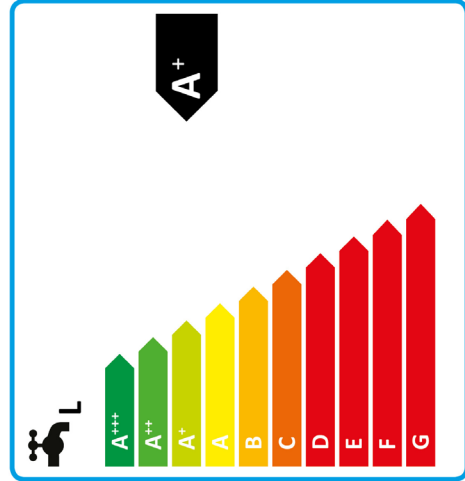
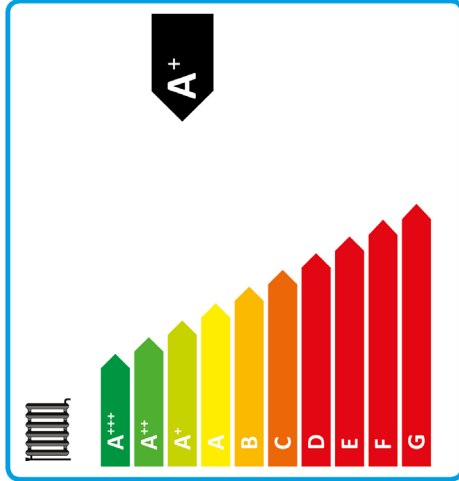

2015

811/2013

ENERG
 енергия · ενεργεια



ENERG
 ενεργεια · энергия



SQKN-YEE 1 TC + MISAN
 -YEE 1 S 2.1 (250L)

Clivet S.p.A.

SQKN-YEE 1 TC + MiSAN-Y
 EE 1 S 2.1 (250L)

Clivet S.p.A.

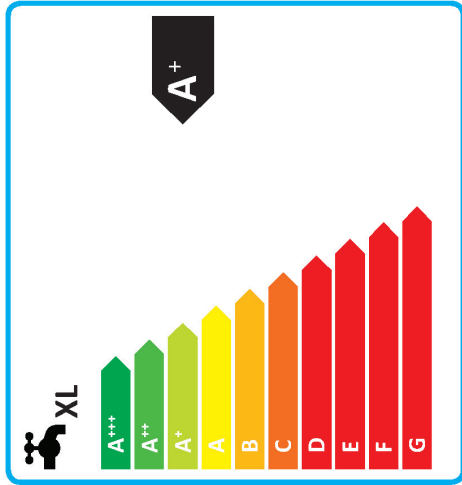
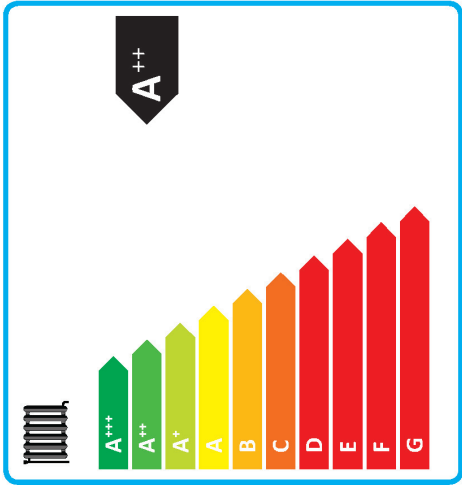
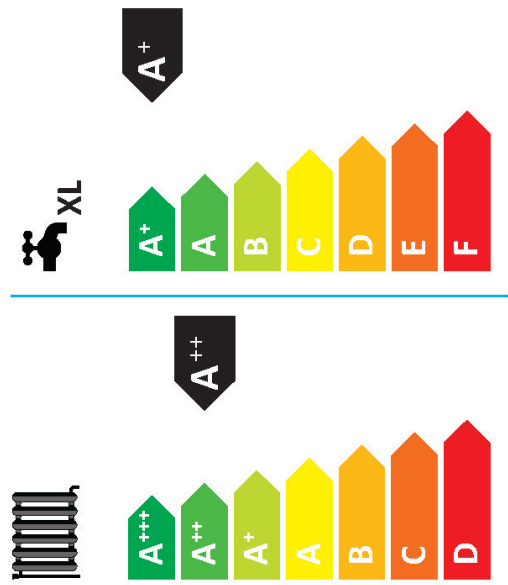

Icons for energy efficiency features:

- Refrigerator icon with A++ label
- Freezer icon with A+ label
- Freezer icon with XL label

Icons for additional features:

- Lighting icon with a plus sign (+)
- Water dispenser icon with a plus sign (+)
- Control panel icon with a plus sign (+)
- Ice maker icon with a plus sign (+)
- Checkmark icon (X) in a box

04 kW
04 kW
 05 kW

41 dB
 55 dB



811/2013

2019

811/2013

2015







ENERG
енергия · ενεργεια

Y IJA
IE IA

SQKN-YEE 1 TC + MiSAN-Y
EE 1 S 3.1 (190L)

Clivet S.p.A.



			
+	+	+	+
<input type="checkbox"/>	<input type="checkbox"/>	<input checked="" type="checkbox"/>	<input type="checkbox"/>



A+++
A++
A+
A
B
C
D
E
F
G

A⁺⁺



A+++
A++
A+
A
B
C
D





A+++
A++
A+
A
B
C
D
E
F
G

A⁺





A⁺
A
B
C
D
E
F



































































































































































































































































































































































































































































































































































ENERG
енергия · ενεργεια

Y IJA
IE IA

SQKN-YEE 1 TC + MiSAN-Y
EE 1 S 3.1 (190L)

Clivet S.p.A.

+	+	+	+

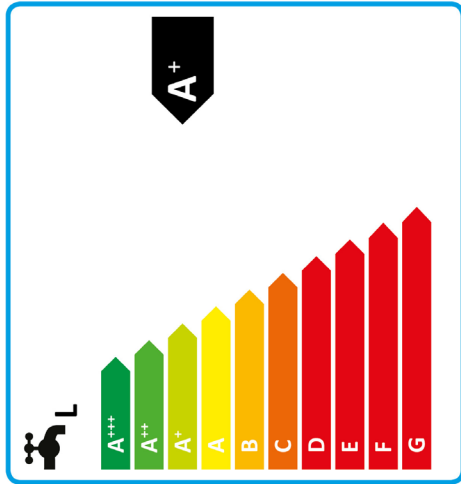
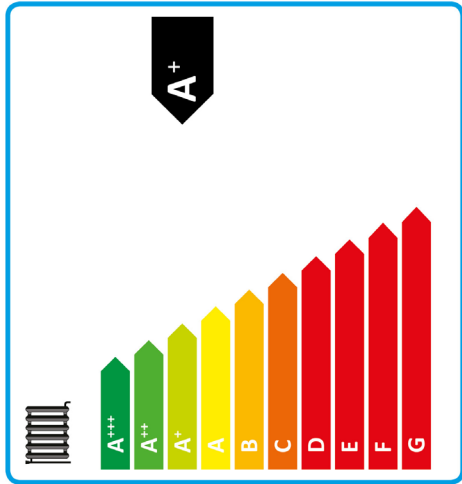

2015

811/2013



ENERG
енергия · ενεργεια

Y IJA
Y IJA

IE IA
IE IA

SQKN-YEE 1 TC + MISAN-Y
EE 1 S 3.1 (250L)

Clivet S.p.A.



A⁺⁺



A⁺



A⁺⁺



A⁺



+



+





+





+











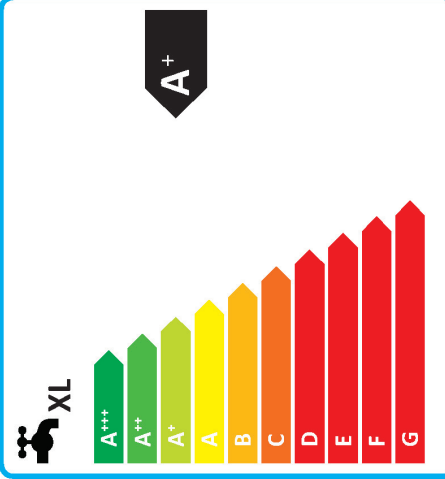

A⁺⁺



A⁺

2015

811/2013



ENERG
енергия · ενεργεια

Y IJA
Y IJA

IE IA
IE IA

SQKN-YEE 1 TC + MISAN
-YEE 1 S 3.1 (250L)

Clivet S.p.A.



A⁺⁺⁺



A⁺⁺



A⁺



A



B



C



D



A⁺



A



B



C



D



E



F



A⁺⁺



A⁺



41 dB



57 dB



05 kW



06 kW



07 kW



2019

811/2013













ENERG
енергия · ενεργεια

Y IJA
IE IA

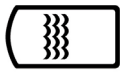
SQKN-YEE 1 TC + MiSAN-Y
EE 1 S 3.1 (250L)

Clivet S.p.A.

			
+	+	+	+
			

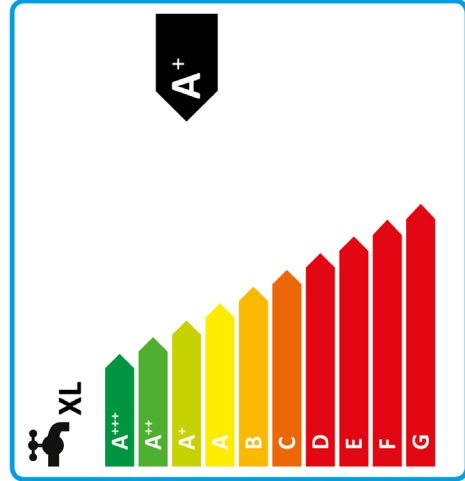
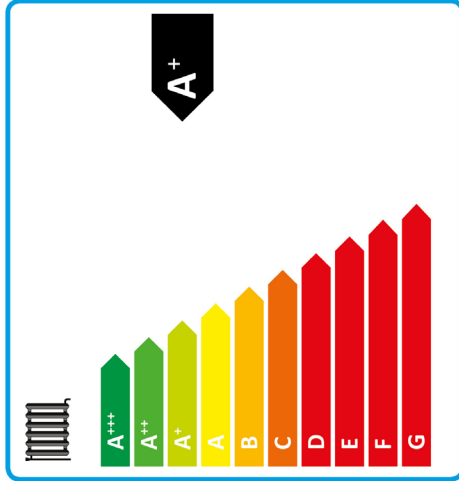

2015

811/2013

ENERG
енергия · ενεργεια



Y IJA
Y IE IA

SQKN-YEE 1 TC + MiSAN-Y
EE 1 S 4.1 (190L)

Clivet S.p.A.

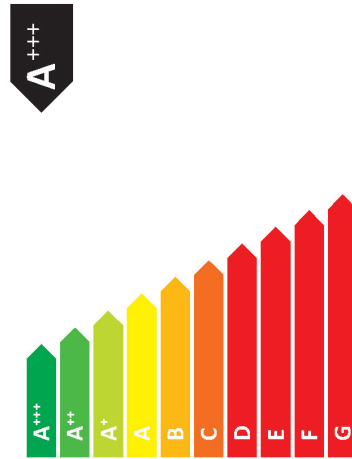

A+++



+

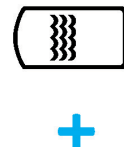

+



+



+

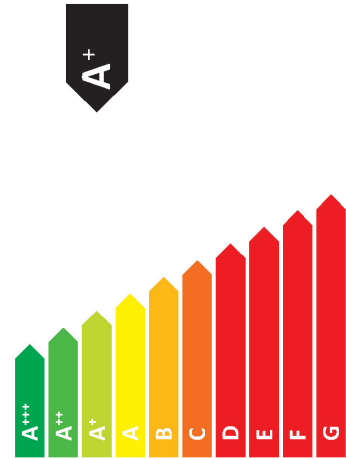

A+



A+

2015

811/2013



ENERG
енергия · ενεργεια

Y IJA
Y IE IA

SQKN-YEE 1 TC + MiSAN
-YEE 1 S 4.1 (190L)

Clivet S.p.A.



A++



A+

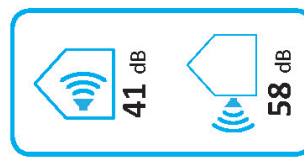

2019

811/2013



ENERG
енергия · ενεργεια

Y IJA
IE IA

SQKN-YEE 1 TC + MiSAN-Y
EE 1 S 4.1 (190L)

Clivet S.p.A.

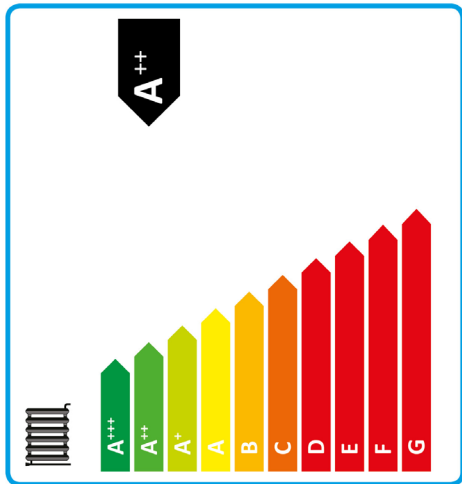

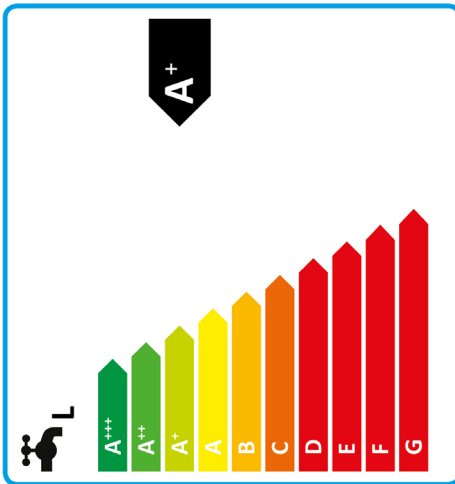

2015

811/2013



ENERG
енергия · ενεργεια

Y IJA
Y IE IA

SQKN-YEE 1 TC + MiSAN-Y
EE 1 S 4.1 (250L)

Clivet S.p.A.

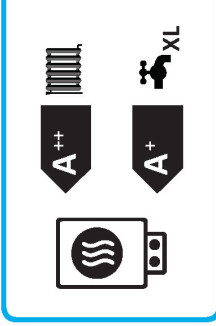

+	+	+	+
□	□	X	□





A+++





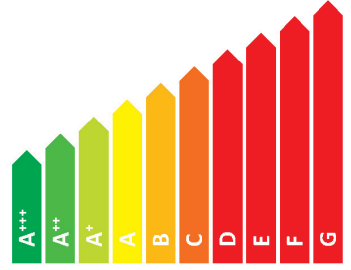

A+







A+++





A+





41 dB



58 dB



07 kW

07 kW

09 kW

2019

811/2013





ENERG
енергия · ενεργεια

Y IJA
Y IE IA

SQKN-YEE 1 TC + MiSAN
-YEE 1 S 4.1 (250L)

Clivet S.p.A.





A+





41 dB



58 dB



07 kW

07 kW

09 kW

2019

811/2013















ENERG
енергия · ενεργεια

Y IJA
IE IA

SQKN-YEE 1 TC + MiSAN-Y
EE 1 S 4.1 (250L)

Clivet S.p.A.

			
+	+	+	+
			

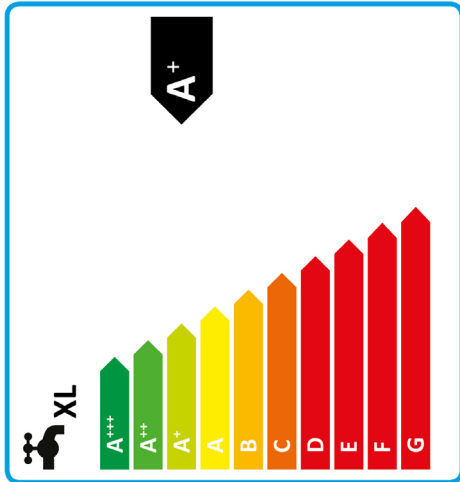
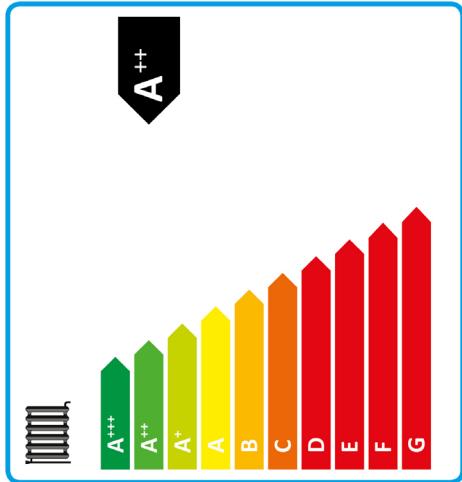

2015

811/2013



ENERG
енергия · ενεργεια

Y IJA
IE IA

SQKN-YEE 1 TC + MiSAN-Y
EE 1 S 5.1 (190L)

Clivet S.p.A.

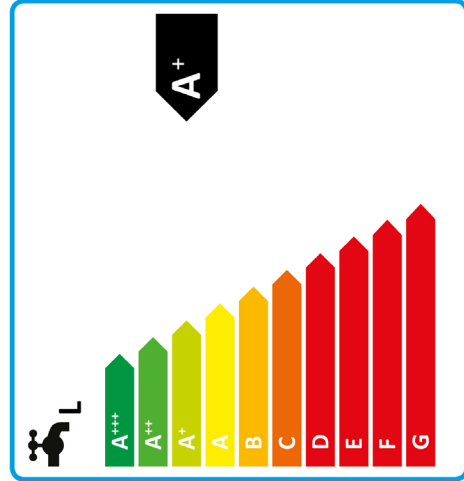
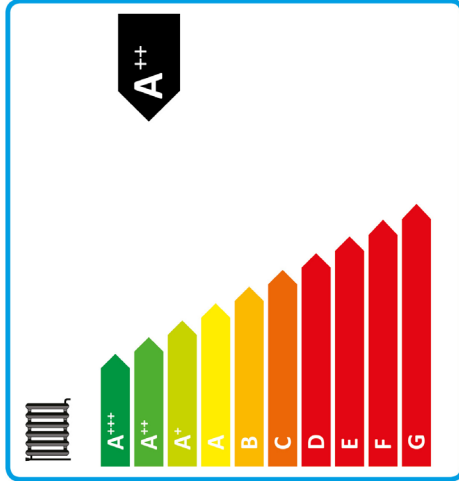

2015

811/2013

ENERG
енергия · ενεργεια



ENERG
енергия · ενεργεια



SQKN-YEE 1 TC + MiSAN-Y
EE 1 S 5.1 (250L)

SQKN-YEE 1 TC + MiSAN
-YEE 1 S 5.1 (250L)

Clivet S.p.A.

Clivet S.p.A.

A⁺⁺
A⁺ XL
A⁺⁺
A⁺ XL



+
+
+
+

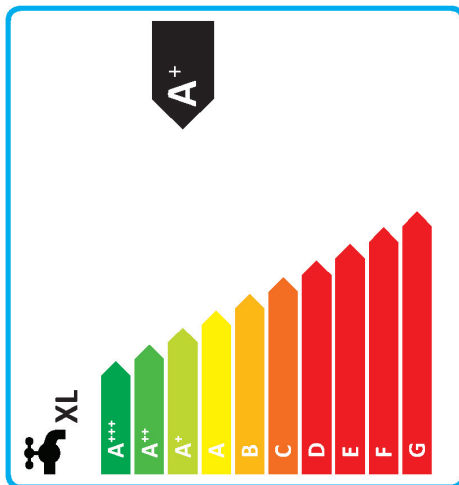

2015

811/2013



41 dB
60 dB

08 kW
09 kW
11 kW



2019

811/2013



ENERG
енергия · ενεργεια

Y IJA
IE IA

SQKN-YEE 1 TC + MiSAN-Y
EE 1 S 5.1 (250L)

Clivet S.p.A.

--	--	--

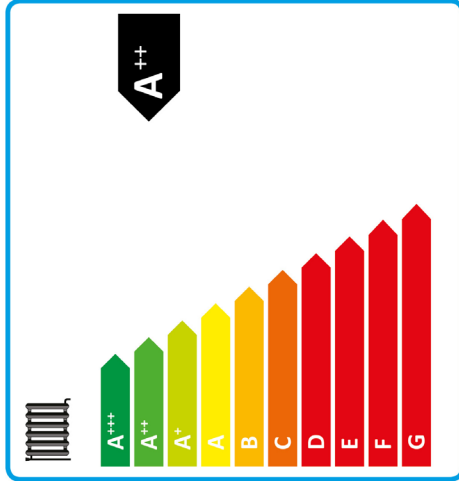

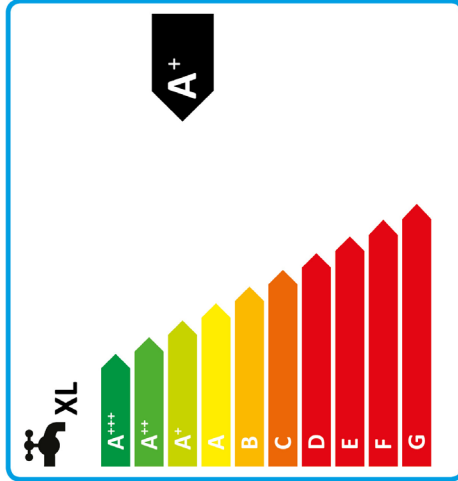

2015

811/2013



ENERG
енергия · ενεργεια



SQKN-YEE 1 TC + MiSAN-Y
EE 1 S 6.1 (250L)

Clivet S.p.A.

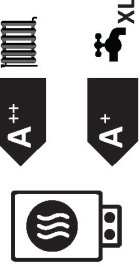

A++

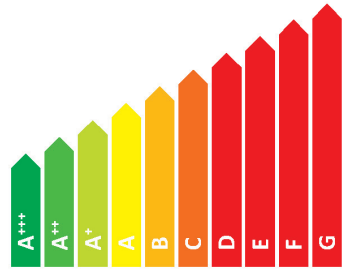

A+

2015

811/2013



ENERG
енергия · ενεργεια



SQKN-YEE 1 TC + MiSAN
-YEE 1 S 6.1 (250L)

Clivet S.p.A.



A++



A+

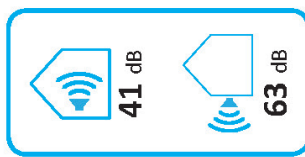

2019

811/2013



ENERG

енергия · ενεργεια



SQKN-YEE 1 TC + MiSAN-Y
EE 1 S 6.1 (250L)

Clivet S.p.A.

Icons for energy label features:

- Energy efficiency class: A++
- Energy efficiency class: A+
- Energy efficiency class: A++
- Energy efficiency class: A+
- Energy efficiency class: A++
- Energy efficiency class: A+
- Energy efficiency class: A++
- Energy efficiency class: A+

Icons for energy label features:

- Lighting: +
- Refrigerator: +
- Control panel: +
- Water dispenser: +
- Energy efficiency class: A++
- Energy efficiency class: A+
- Energy efficiency class: A++
- Energy efficiency class: A+
- Energy efficiency class: A++
- Energy efficiency class: A+
- Energy efficiency class: A++
- Energy efficiency class: A+
- Energy efficiency class: A++
- Energy efficiency class: A+

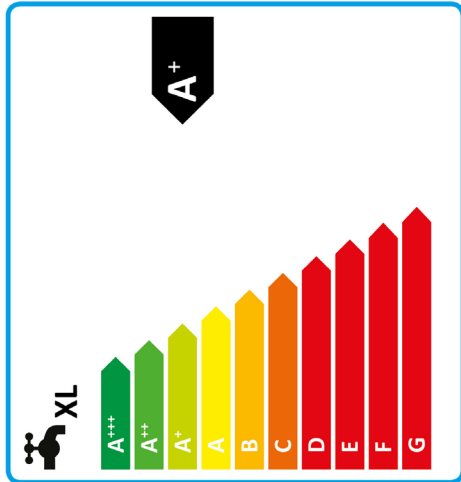
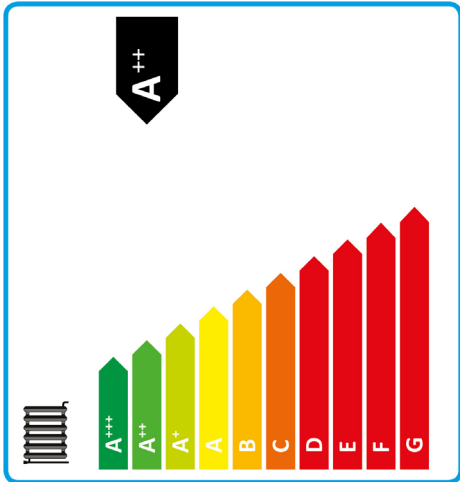

2015

811/2013

ENERG
енергия · ενεργεια



ENERG
енергия · ενεργεια



SQKN-YEE 1 TC + MiSAN-Y
EE 1 S 7.1 (250L)

SQKN-YEE 1 TC + MiSAN
-YEE 1 S 7.1 (250L)

Clivet S.p.A.

Clivet S.p.A.

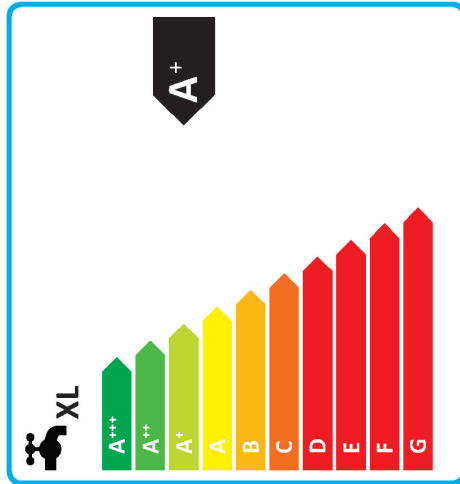
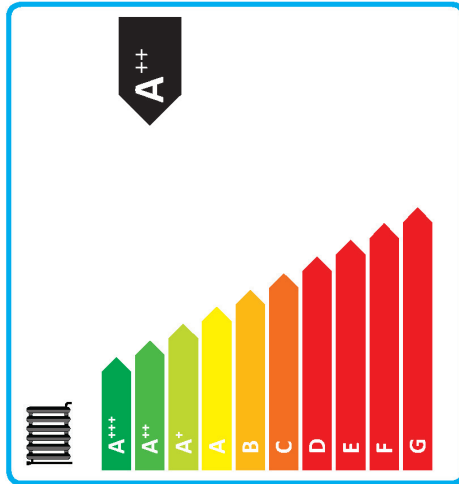

41 dB

13 kW



2019

811/2013

2015

811/2013



ENERG
енергия · ενεργεια

Y IJA
IE IA

SQKN-YEE 1 TC + MiSAN-Y
EE 1 S 7.1 (250L)

Clivet S.p.A.

+	+	+	+

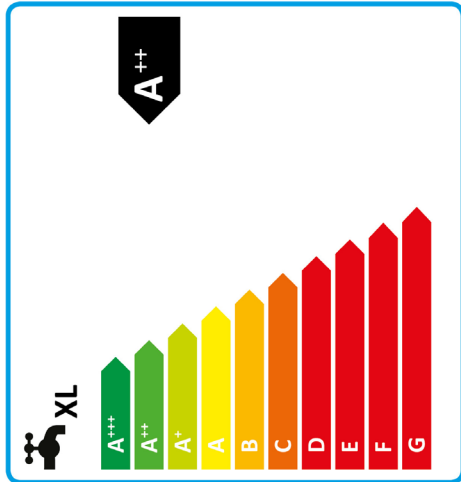
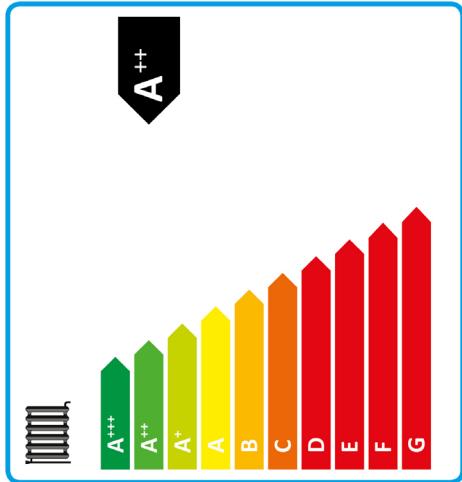

2015

811/2013

ENERG
енергия · ενεργεια



ENERG
енергия · ενεργεια



SQKN-YEE 1 TC + MiSAN
-YEE 1 S 8.1 (250L)

Clivet S.p.A.

SQKN-YEE 1 TC + MiSAN-Y
EE 1 S 8.1 (250L)

Clivet S.p.A.

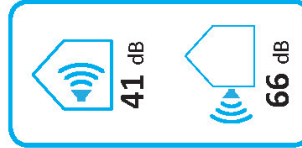
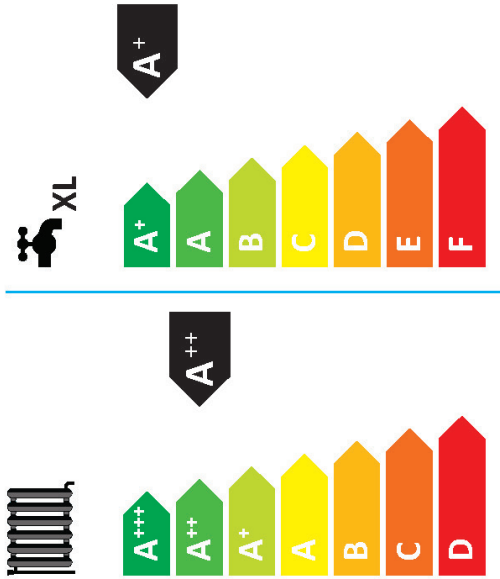

811/2013

2019

+	+	+	+

811/2013

2015



ENERG

енергия · ενεργεια



SQKN-YEE 1 TC + MiSAN-Y
EE 1 S 8.1 (250L)

Clivet S.p.A.

Icons for energy efficiency features:

- Energy label A++
- Energy label A+
- Energy label A++ with XL icon
- Energy label A+ with XL icon

Icons for appliance features:

- Lighting icon (+)
- Water filter icon (+)
- Control panel icon (+)
- Water dispenser icon (+)
- Empty box icon
- Empty box icon
- Box with X icon
- Box with X icon

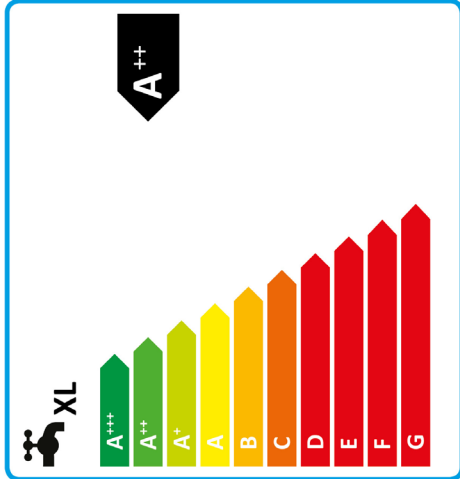
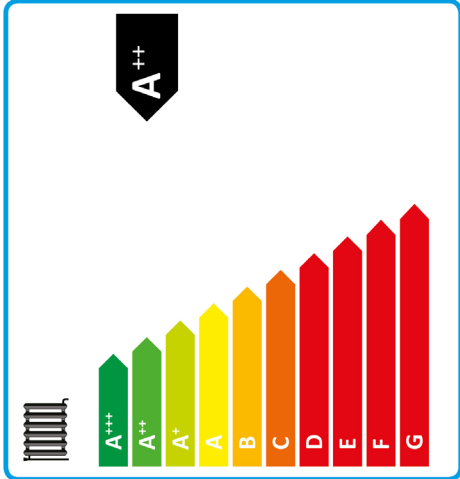

2015

811/2013

FOR OVER 30 YEARS, WE HAVE BEEN OFFERING
SOLUTIONS TO ENSURE SUSTAINABLE
COMFORT AND THE WELL-BEING OF PEOPLE
AND THE ENVIRONMENT



Info & Contacts: www.clivet.com



MideaGroup
humanizing technology