

Date 13/5/2020
 Customer
 Offer



San Toribio, 6 28031 MADRID
 +34/913030426 com@frimetal.es

DIRECT EXPANSION EVAPORATOR

FRM-1145

Model Capacity **22,4 kW**
 Required Capacity **0,0 kW**

Materials

Tubes Copper
 Fins Aluminium
 Casing Aluminun and galvanized steel white coated RAL-9002

Duties

Fin Spacing **4,2 mm**
 Air Flow **9620 m³/h**
 Air Velocity **2,27 m/s**
 Available Air Static Pressure **0 Pa**
 Air throw **15 m**
 Air Inlet Temperature **3,0 °C**
 Outlet Air Temperature **-1,9 °C**
 Evaporating Temperature **-5,0 °C**
 Temperature difference DT1 **8 K**
 Refrigerant **R449A**

Coil

Fin Spacing **4,2 mm**
 Finned Length **2100 mm**
 Surface **112,0 m²**
 Internal Volume **22,3 dm³**

Installer Information

Net weight **120 kg**
 Inlet liquid distributor **1 x 22 mm**
 Outlet line **1 x 35 mm**

AC Fan motors ErP compliant

Power supply	1~230V/50Hz	Total absorbed power	480 W
Fans Nr.	3	Total absorbed current	2,2 A
Blade Diameter	400 mm	Noise Power Level	78 dB(A)
Speed	1400 rpm	Noise Pressure Level	47 dB(A)
		Distance	10 m

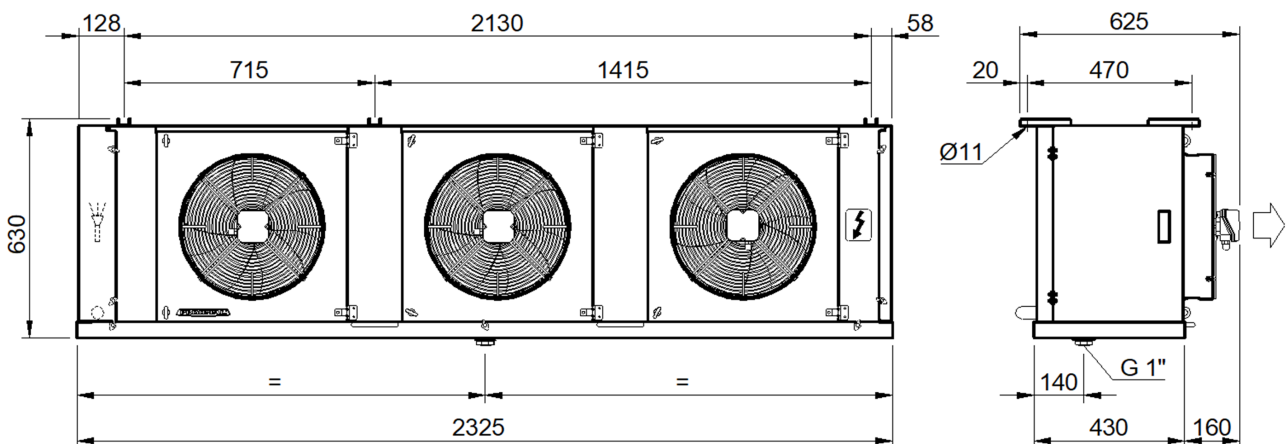

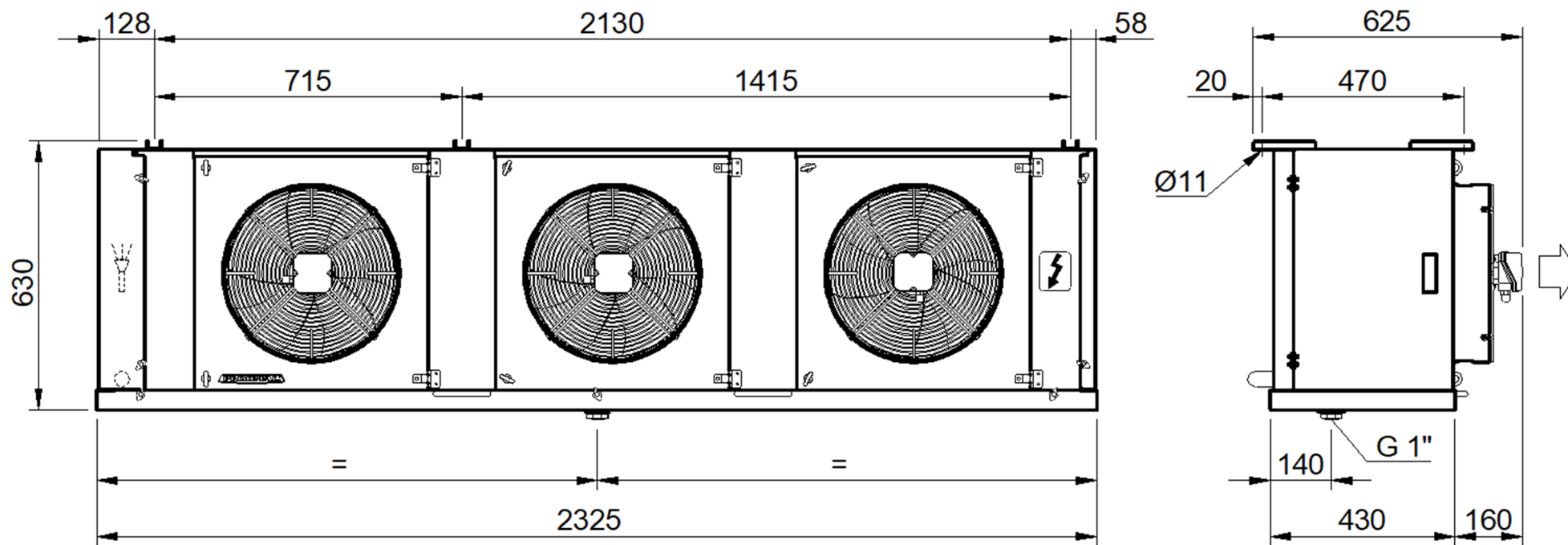

DIRECT EXPANSION EVAPORATOR - FRM-1145



FRIMETAL, s.a.
 San Toribio, 6
 28031 MADRID
 +34/913030426 - +34/917774761