

SPHERA EVO 2.0

SQKN-YEE 1 TC+MiSAN-YEE 1 S 2.1-8.1



CONTENTS

Part 1	General Information	4
Part 2	Component Layout and Refrigerant Circuits.....	6
Part 3	Control	15
Part 4	Diagnosis and Troubleshooting.....	29



Part 1 General Information

1 External Appearance.....	4
----------------------------	---

1 External Appearance

1.1 Outdoor Unit Appearance

Table 1-1.1: Outdoor unit appearance

MiSAN-YEE 1 S 2.1 - 3.1	MiSAN-YEE 1 S 4.1 - 8.1
	

1.2 Indoor Unit

Table 1-1.2: Indoor unit appearance

SQKN-YEE 1 TC 190L	SQKN-YEE 1 TC 250L
	

Outdoor unit

Size	2.1-3.1	4.1 -5.1	6.1 - 8.1	6.1 - 8.1
Power supply	single-phase			three-phase

Part 2

Component Layout and Refrigerant Circuits

1 Layout of Functional Components	7
2 Piping Diagrams	12
3 Refrigerant Flow Diagrams.....	14

1 Layout of Functional Components

1.1 Outdoor Unit Layout

MiSAN-YEE 2.1 - 3.1 (single-phase)

Figure 2-1.1: top view

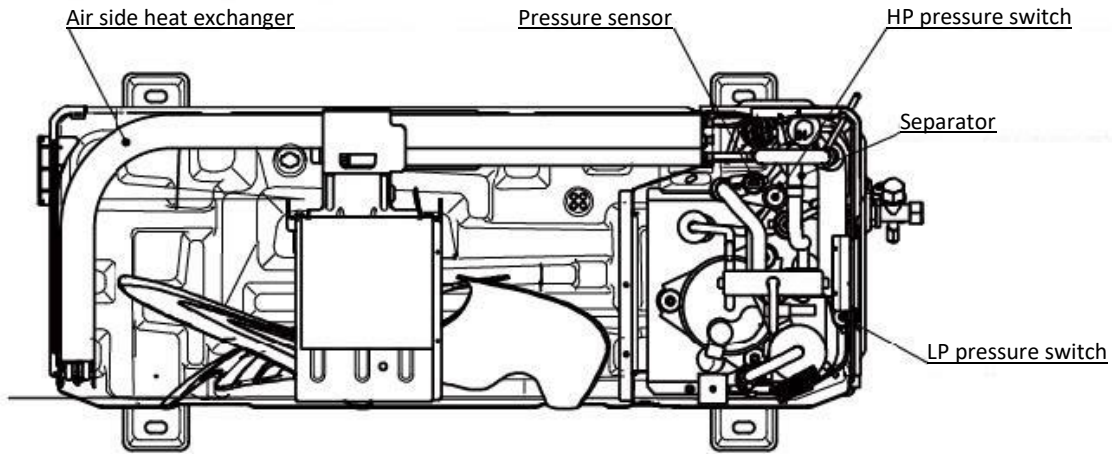
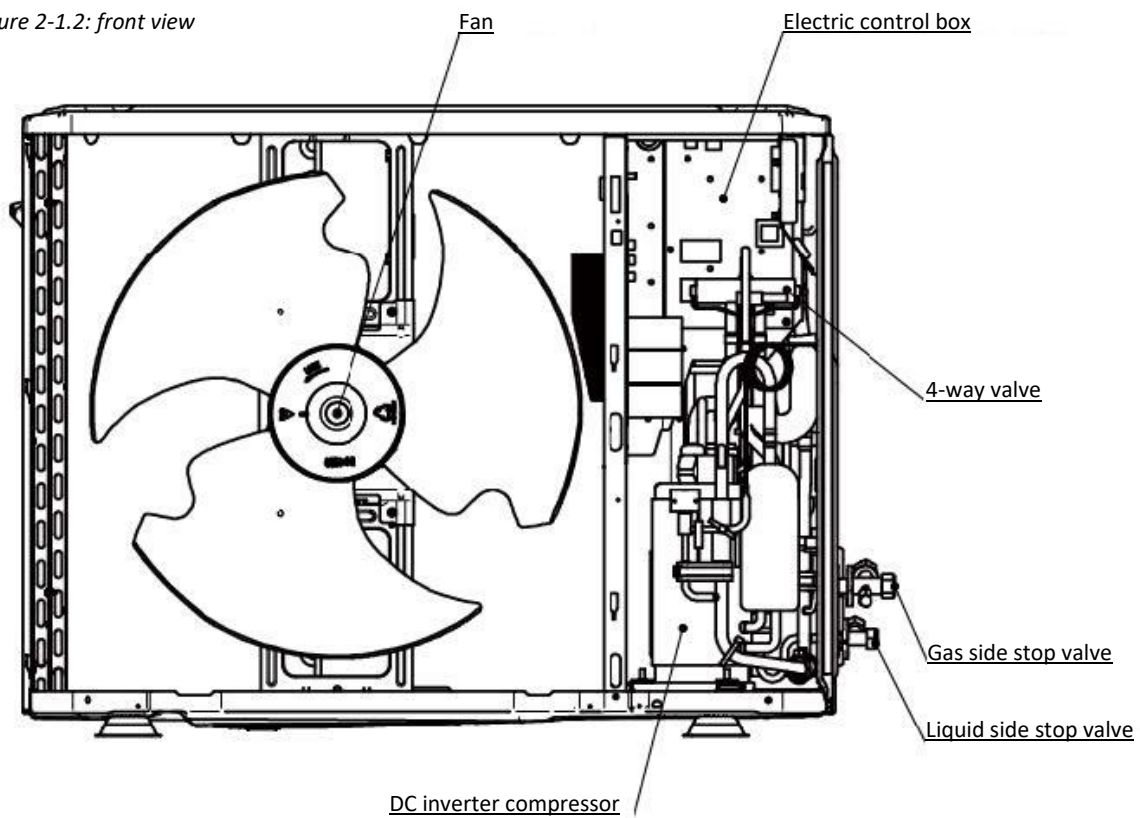

Figure 2-1.2: front view



MISAN-YEE 4.1 - 5.1 (single-phase)

Figure 2-1.3: top view

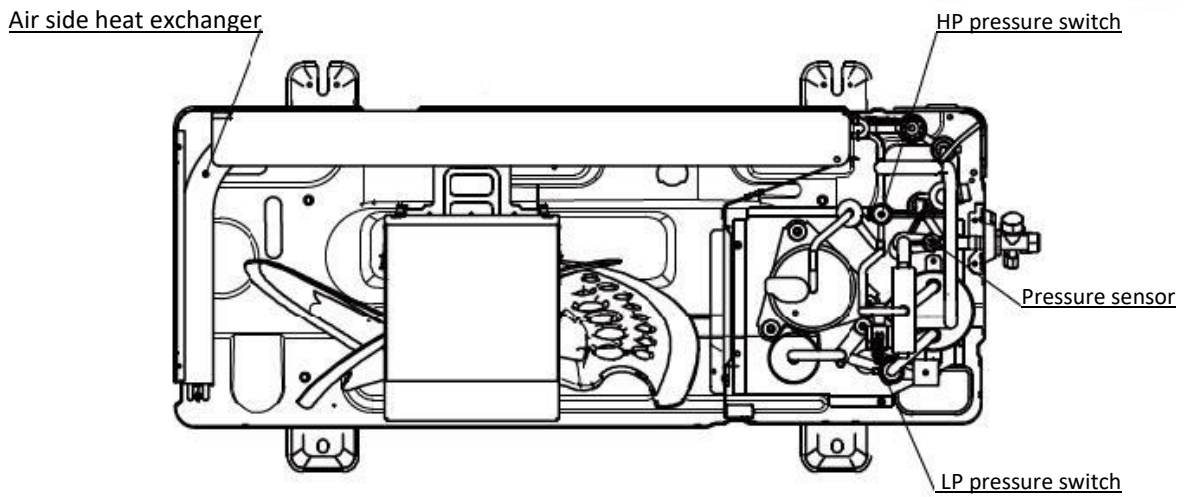
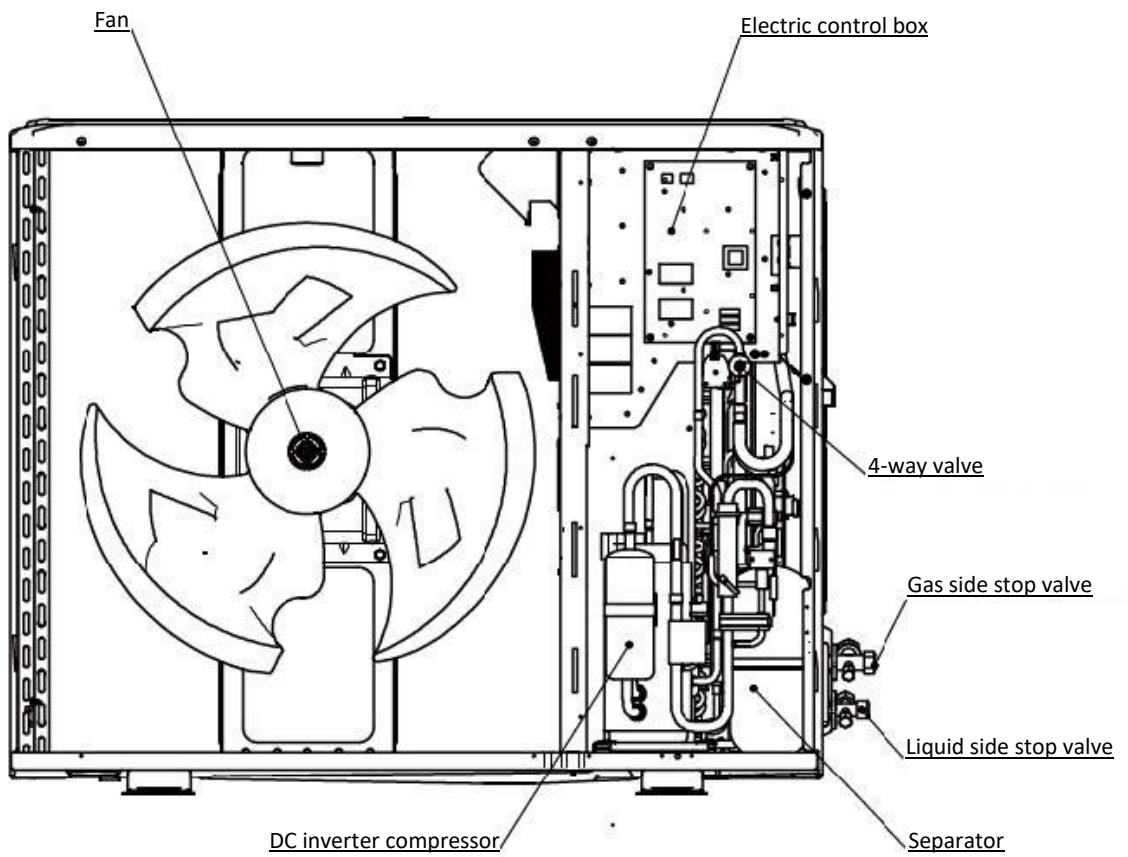

Figure 2-1.4: front view



MISAN-YEE 6.1 - 8.1 (single-phase)

Figure 2-1.5: top view

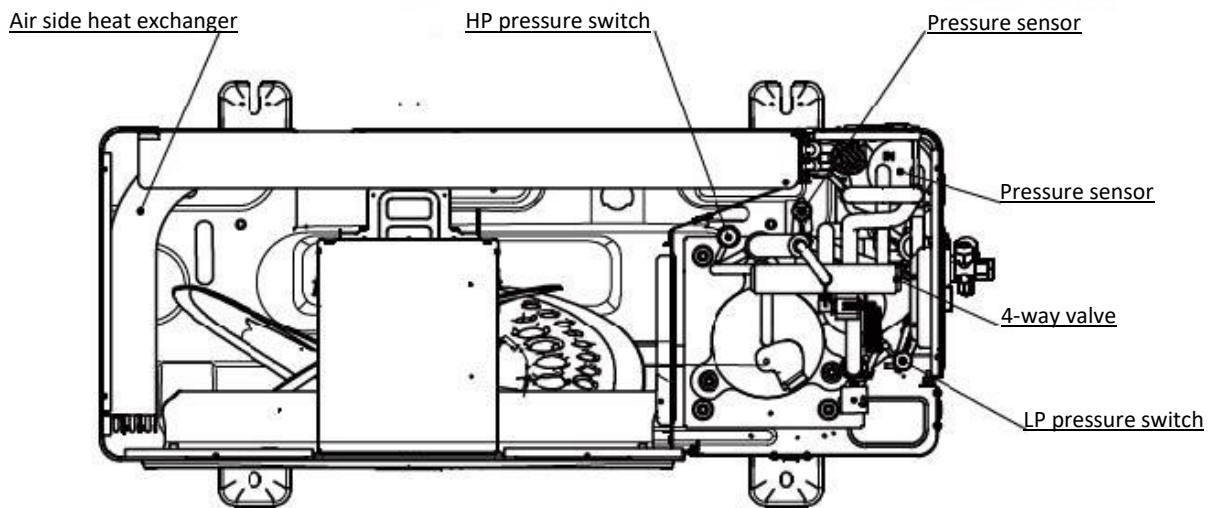
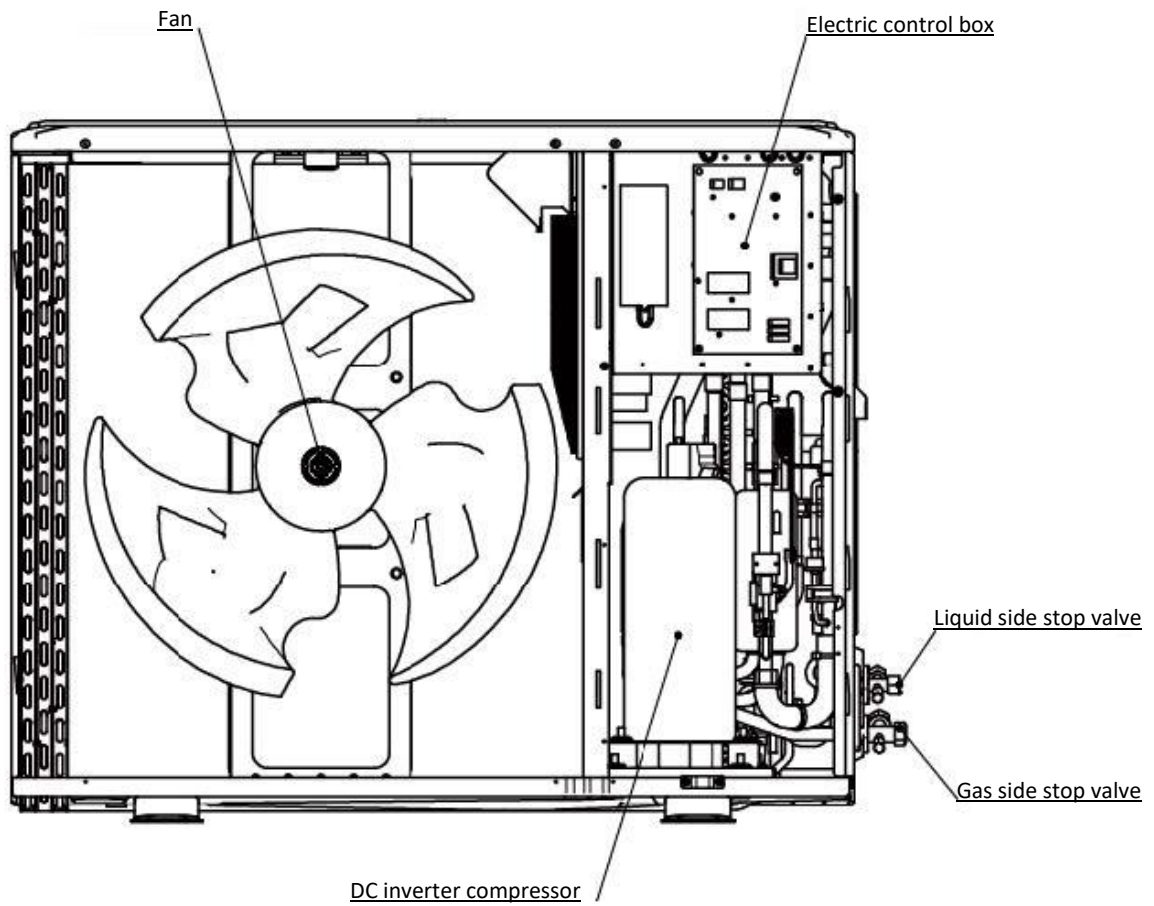

Figure 2-1.6: front view



MISAN-YEE 6.1 - 8.1 (three-phase)

Figure 2-1.7: top view

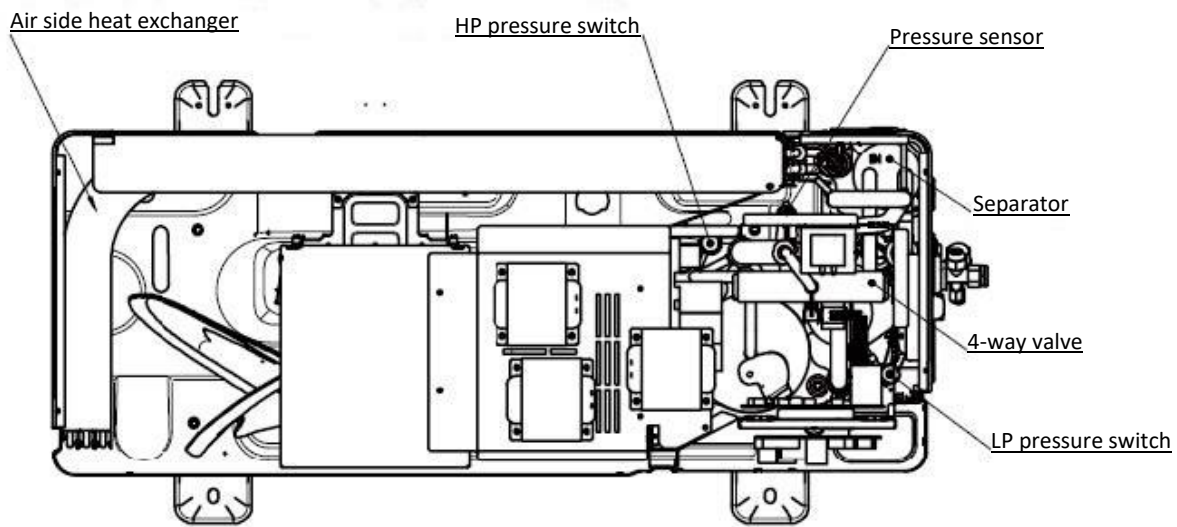
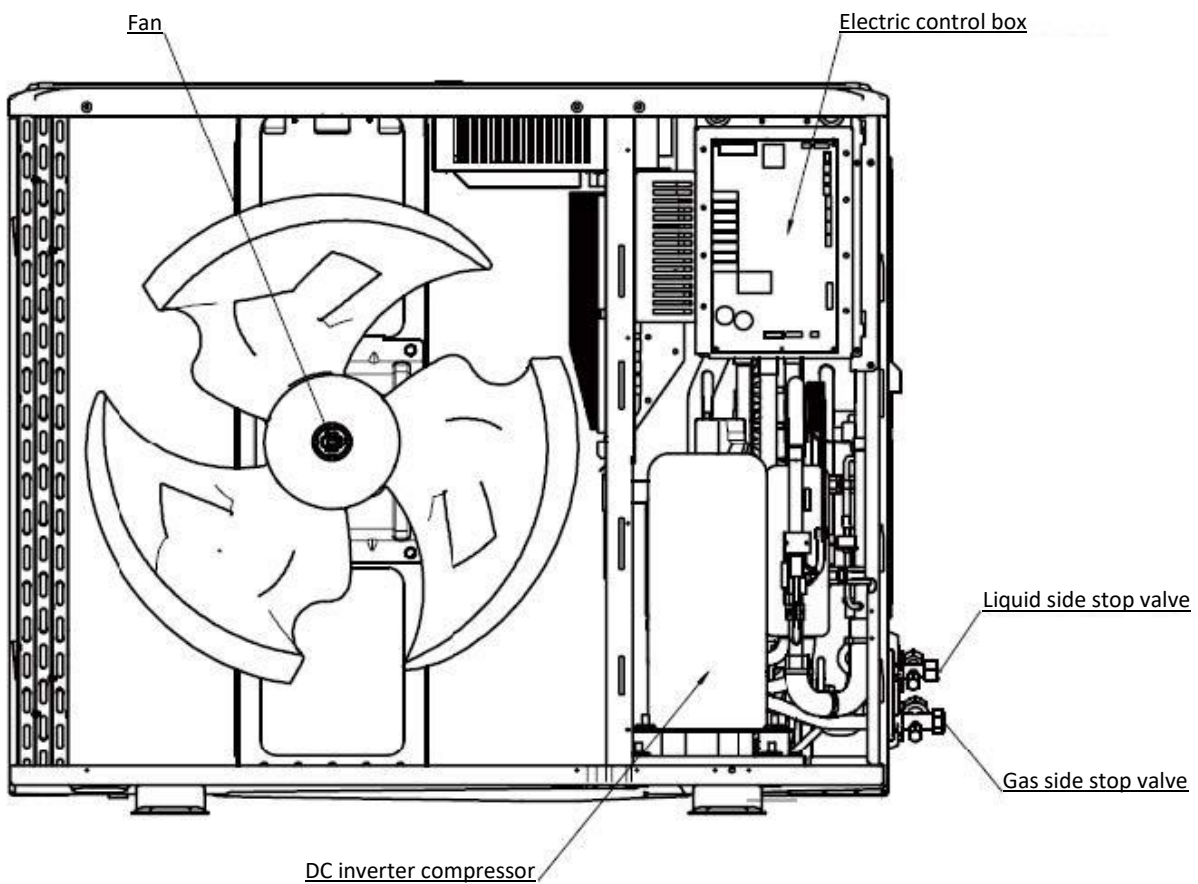
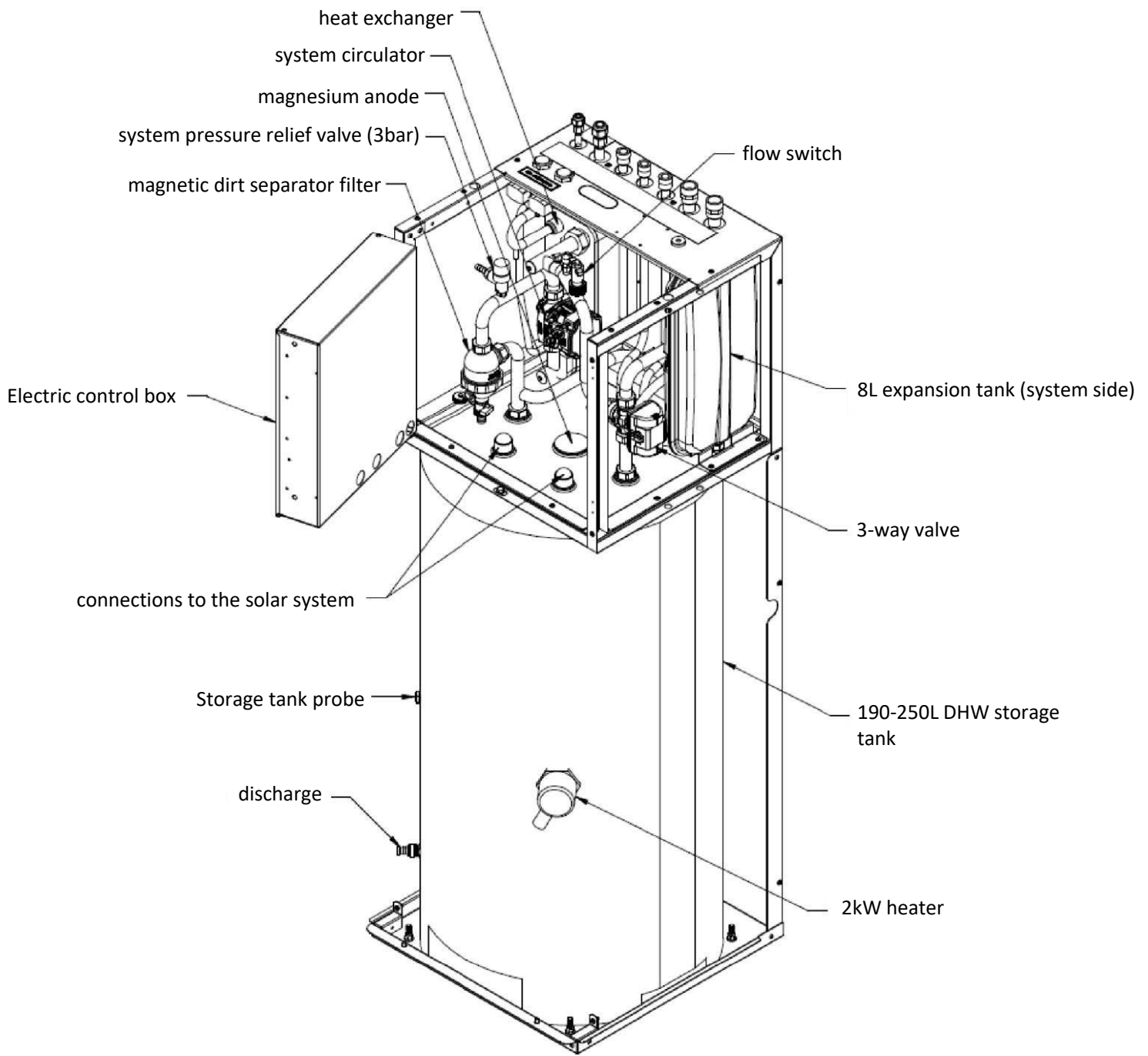

Figure 2-1.8: front view



1.2 Indoor Unit Layout



2 Refrigeration Circuit Diagram

2.1 Outdoor Unit Piping

Figure 2-2.1: water diagram

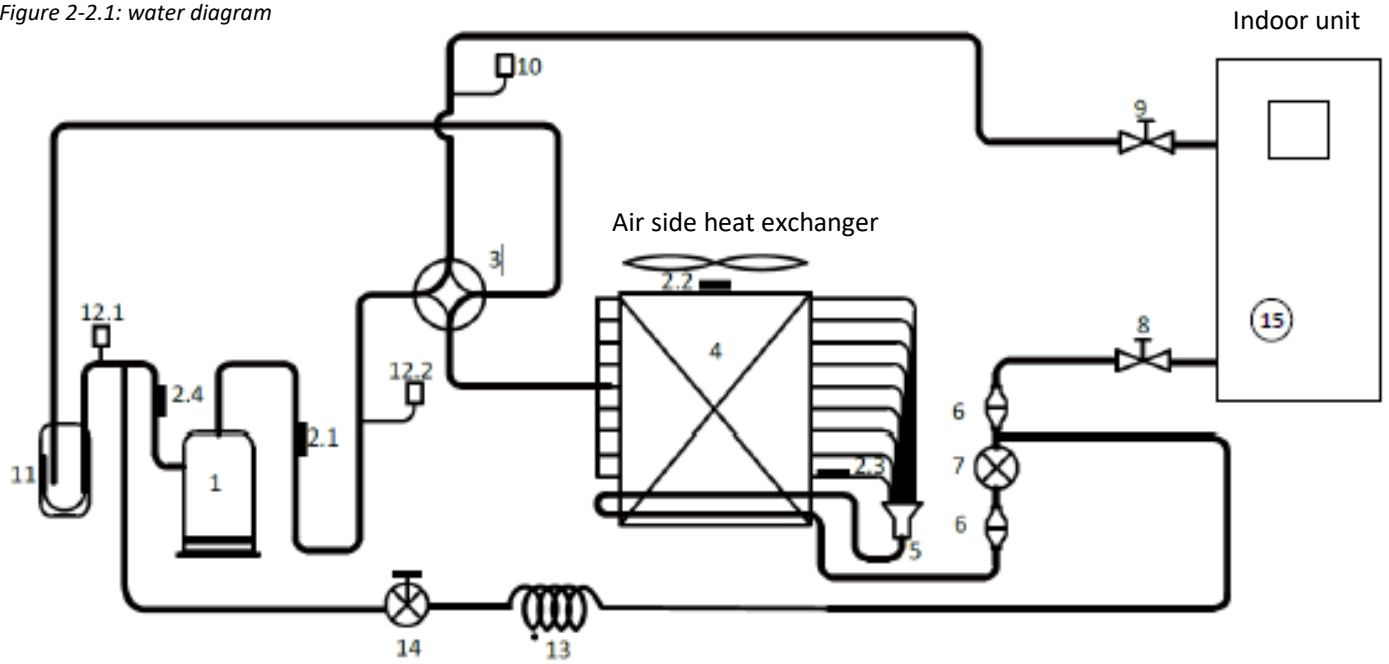

Key			
1	Compressor	8	Stop valve (liquid side)
2.1	Compressor discharge pipe temperature sensor	9	Stop valve (gas side)
2.2	Outdoor ambient temperature sensor	10	Pressure sensor
2.3	Air side heat exchanger refrigerant outlet temperature sensor	11	Separator
2.4	Compressor suction pipe temperature sensor	12	LP pressure switch
3	4-way valve	13.1	HP pressure switch
4	Air side heat exchanger	13.2	Capillary
5	Distributor	14	Solenoid valve
6	Filter	15	Water side exchanger
7	Electronic expansion valve		

Key components:

1. Compressor:

rotary, variable speed, inverter-controlled. Compresses the gas, generating a positive effect.

2. Temperature sensors:

detect the temperatures of the refrigeration cycle for control of the unit and its safety devices

3. 4-way valve:

controls refrigerant flow direction. Closed in cooling mode and open in heating mode. When closed, the air side heat exchanger functions as a condenser and water side heat exchanger functions as an evaporator. When open, the air side heat exchanger functions as an evaporator and water side heat exchanger function as a condenser.

4. Air side exchanger:

Finned coil with variable speed fan. Exchanges heat with the outdoor heat source/sink by releasing or absorbing thermal energy from the air

7. Electronic expansion valve (EXV):

Controls refrigerant flow and reduces refrigerant pressure.

11. Separator:

Separates liquid refrigerant from gas refrigerant to protect compressor from liquid hammering. Air side heat exchanger

12/13. High and low pressure switches:

Regulate refrigerant system pressure. When refrigerant system pressure rises above the upper limit or falls below the lower limit, the high or low pressure switches turn off, stopping the compressor.

2.2 Water Circuit Diagram

SQKN-YEE 1 TC - 190 L/250 L

Figure 2-2.2: water diagram

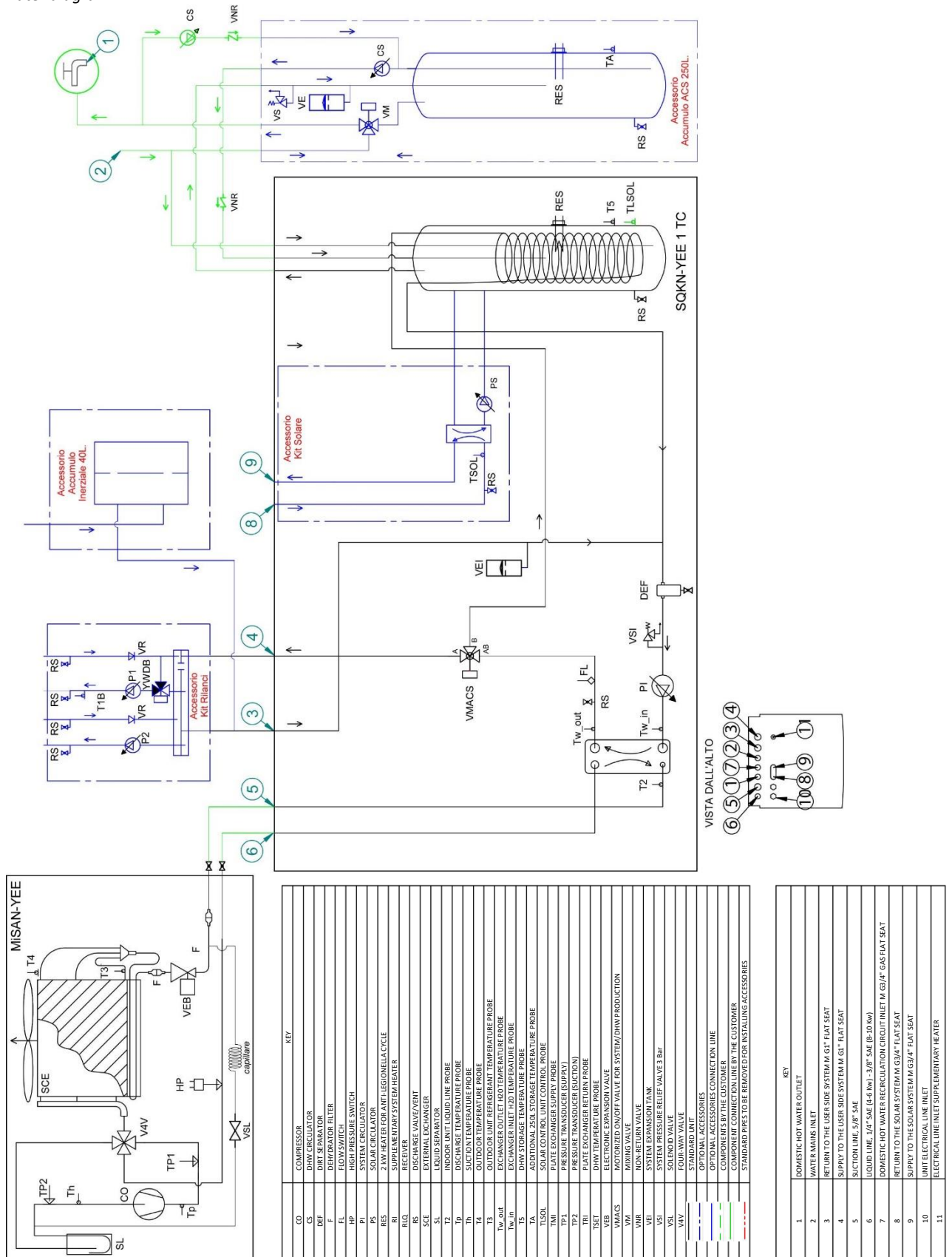

3 Refrigerant Flow Diagrams

Heating and domestic hot water operation

Figure 2-3.1: refrigerant flow during heating or domestic hot water operation

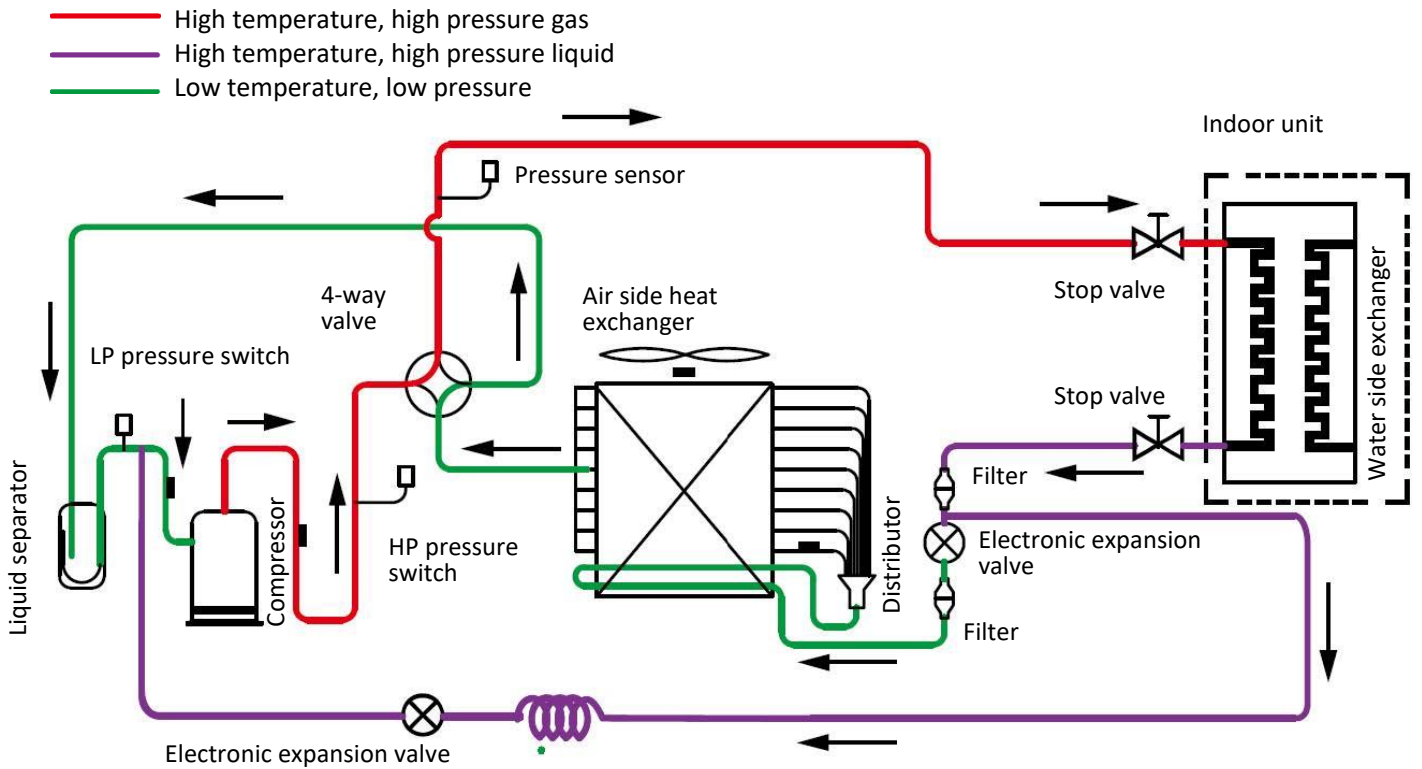

Cooling and defrosting operation

Figure 2-3.2: refrigerant flow during cooling and defrosting operations

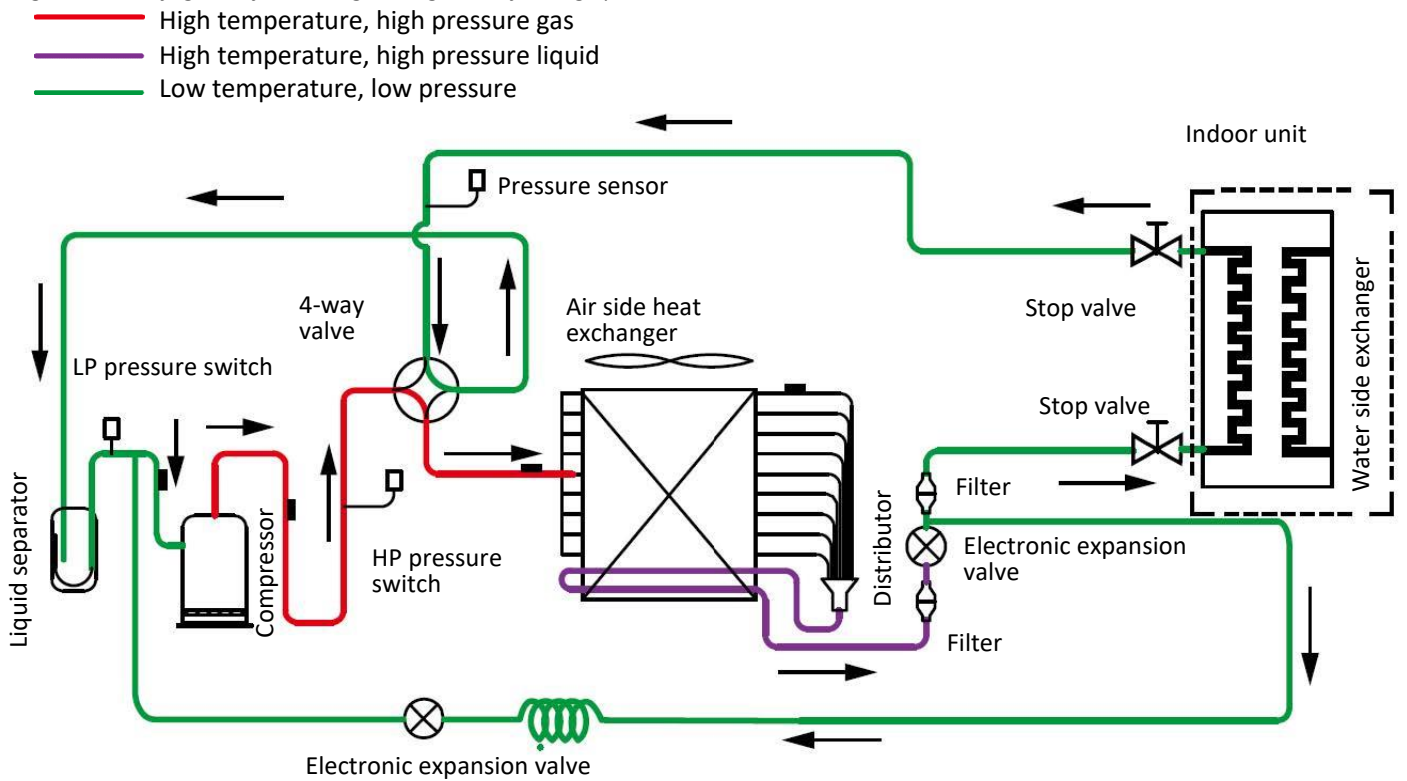

Part 3

Control

1 Stop Operation	16
2 Standby Control	16
3 Startup Control	17
4 Normal Operation Control	20
5 Protection Control	22
6 Special Control.....	25
7 Role of Temperature Sensors in Control Functions.....	27

1 Stop Operation

The stop operation occurs for one of the following reasons:

1. Abnormal shutdown: in order to protect the compressors, if an abnormal state occurs the system makes a stop with thermo off operation and an error code is displayed on the outdoor unit PCB digital displays and on the user interface.
2. The system stops when the set temperature has been reached.

2 Standby Control

2.1 Crankcase Heater Control

The crankcase heater is used to prevent refrigerant from mixing with compressor oil when the compressors are stopped. The crankcase heater is controlled according to outdoor ambient temperature and the compressor on/off state. When the outdoor ambient temperature is above 8°C or the compressor is running, the crankcase heater is off. When the outdoor ambient temperature is at or below 8°C and either the compressor has been stopped for more than 3 hours or the unit has just been switched-on (either manually or when the power has returned following a power outage), the crankcase heater turns on.

2.2 Water Circulator Control

There are several cases depending on the type of control set on the unit:

1. Control of system water temperature:
 - when the set point is reached, the internal circulator continues to run continuously
2. Control by ambient thermostat:
 - when the set point is reached, the internal circulator stops
 - when the set point is reached, the internal circulator switches on every 6 hours for 3 minutes

Note: the internal circulator operates continuously during defrosting and antifreeze operations.

3 Startup Control

3.1 Compressor Startup Delay Control

In initial startup control and in restart control (except in oil return operation and defrosting operation), compressor startup is delayed such that a minimum time has elapsed, in order to prevent frequent compressor on/off and to equalize the pressure within the refrigeration circuit. The compressor re-start delays for cooling and heating modes are set on the user interface. Refer to the Installation manual of Sphera EVO 2.0 > chapter 9 Heating/Cooling mode setting.

3.2 Compressor Startup Program

In initial startup control and in re-start control, compressor startup is controlled according to outdoor ambient temperature. Compressor startup follows one of two startup programs until the target rotation speed is reached. Refer to Figures 3-3.1 and 3-3.2.

Figure 3-3.1: MiSAN-YEE 1 S 2.1 - 3.1 single-phase compressor startup program1 when ambient temperature is above 3°C

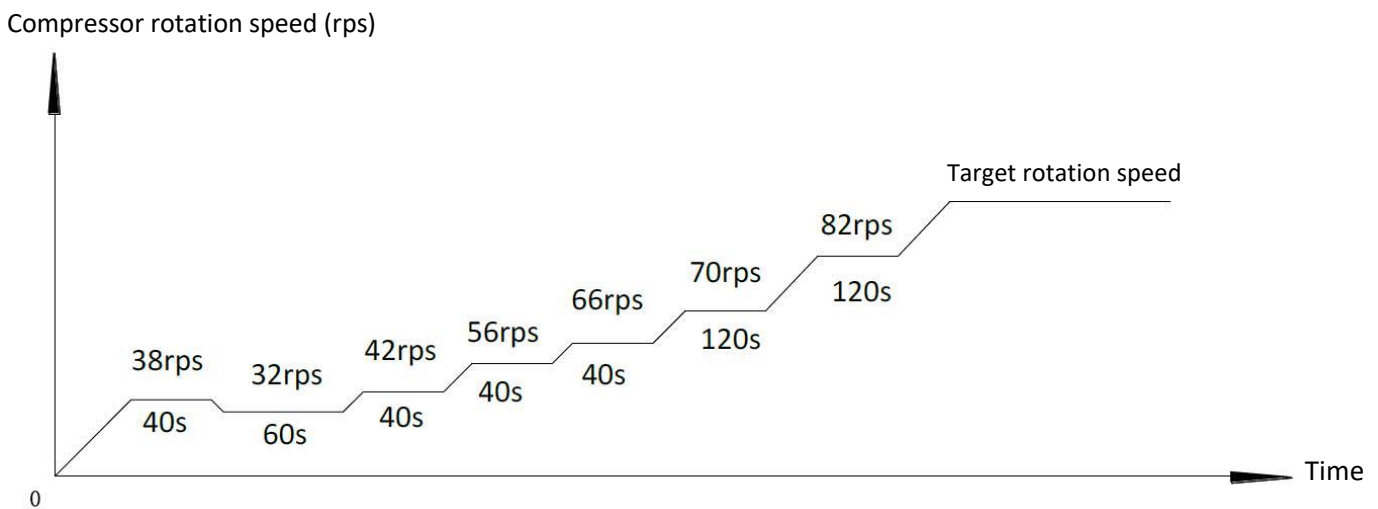

- Notes:
- Once the first, 40-second stage of the program is complete, the program proceeds to the subsequent stages in a step-by-step fashion and exits when the target rotation speed has been reached.

Figure 3-3.2: MiSAN-YEE 1 S 2.1 - 3.1 single-phase compressor startup program1 when ambient temperature is at or below 3°C

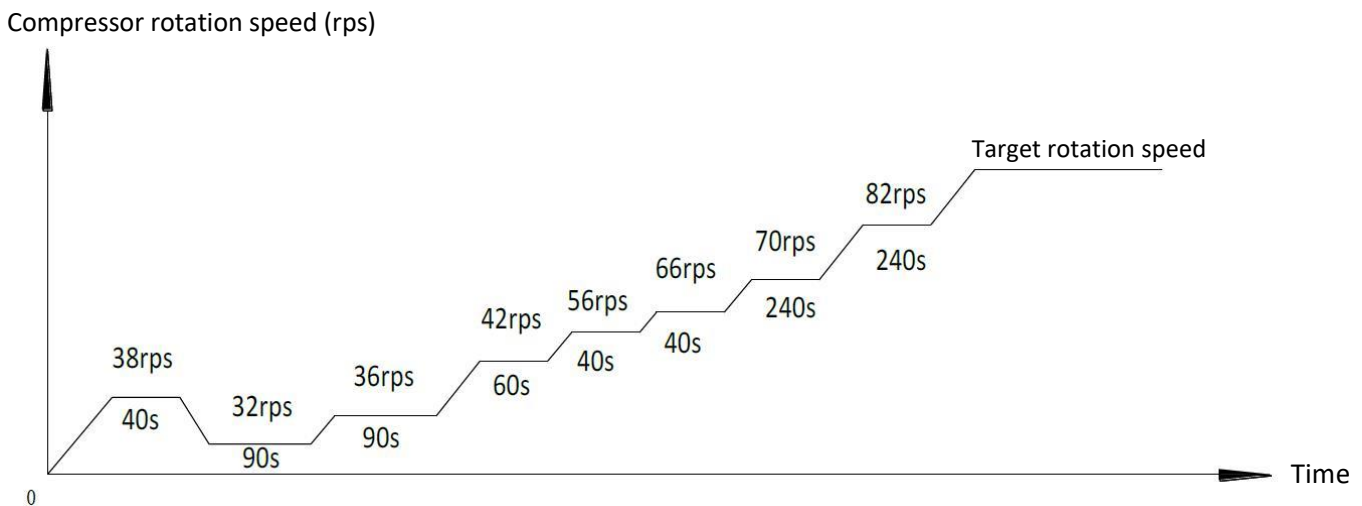

- Notes:
- Once the first, 40-second stage of the program is complete, the program proceeds to the subsequent stages in a step-by-step fashion and exits when the target rotation speed has been reached.

Figure 3-3.3: MiSAN-YEE 1 S 4.1 - 5.1 single-phase compressor startup program1 when ambient temperature is above 11°C

Compressor rotation speed (rps)

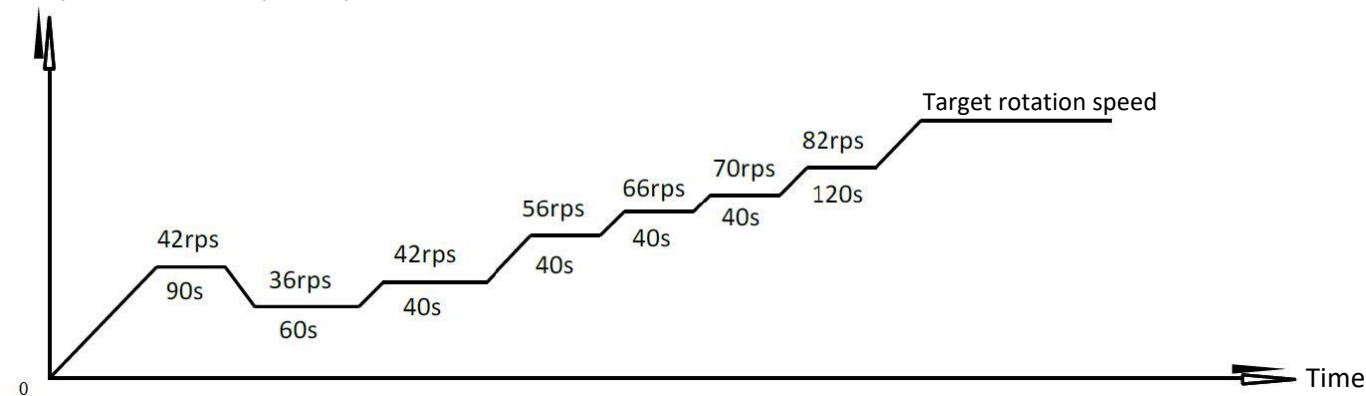

- Notes:
1. Once the first, 90-second stage of the program is complete, the program proceeds to the subsequent stages in a step-by-step fashion and exits when the target rotation speed has been reached.

Figure 3-3.4: MiSAN-YEE 1 S 4.1 - 5.1 single-phase compressor startup program1 when ambient temperature is at or below 11°C

Compressor rotation speed (rps)

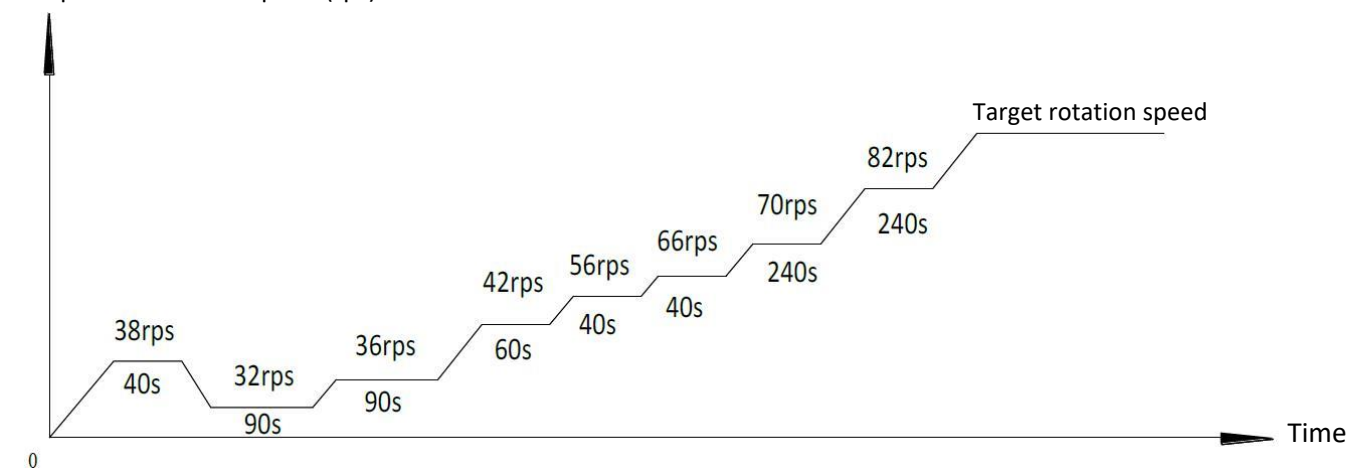

- Notes:
1. Once the first, 40-second stage of the program is complete, the program proceeds to the subsequent stages in a step-by-step fashion and exits when the target rotation speed has been reached.

Figure 3-3.5: MiSAN-YEE 1 S 6.1 - 8.1 single-phase / three-phase compressor startup program1 when ambient temperature is at or below 3°C

Compressor rotation speed (rps)

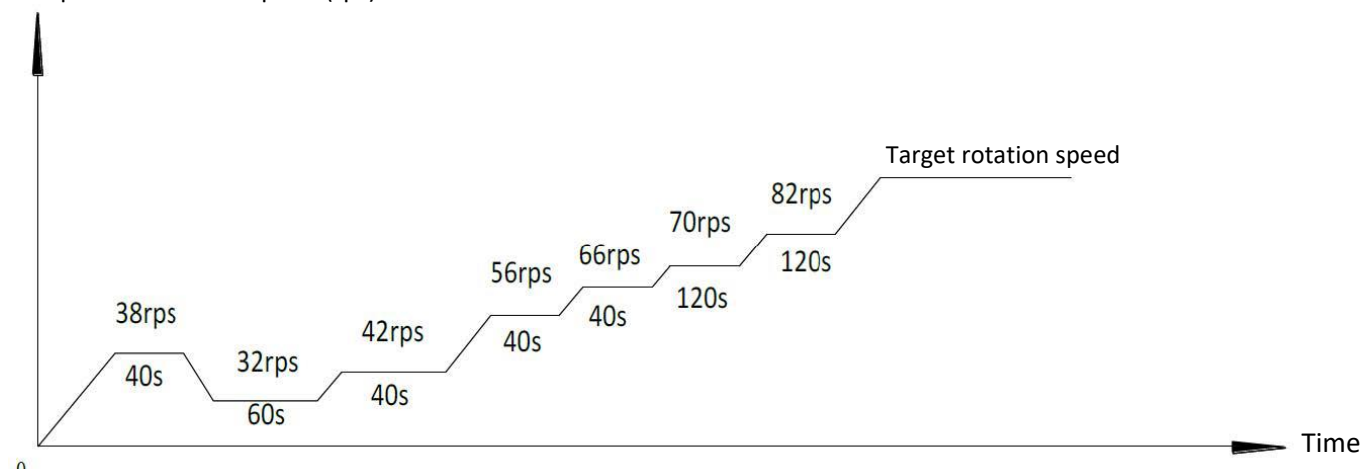

- Notes:
1. Once the first, 40-second stage of the program is complete, the program proceeds to the subsequent stages in a step-by-step fashion and exits when the target rotation speed has been reached.

Figure 3-3.6: MiSAN-YEE 1 S 6.1 - 8.1 single-phase / three-phase 1 compressor1 startup program when ambient temperature is at or below 3°C

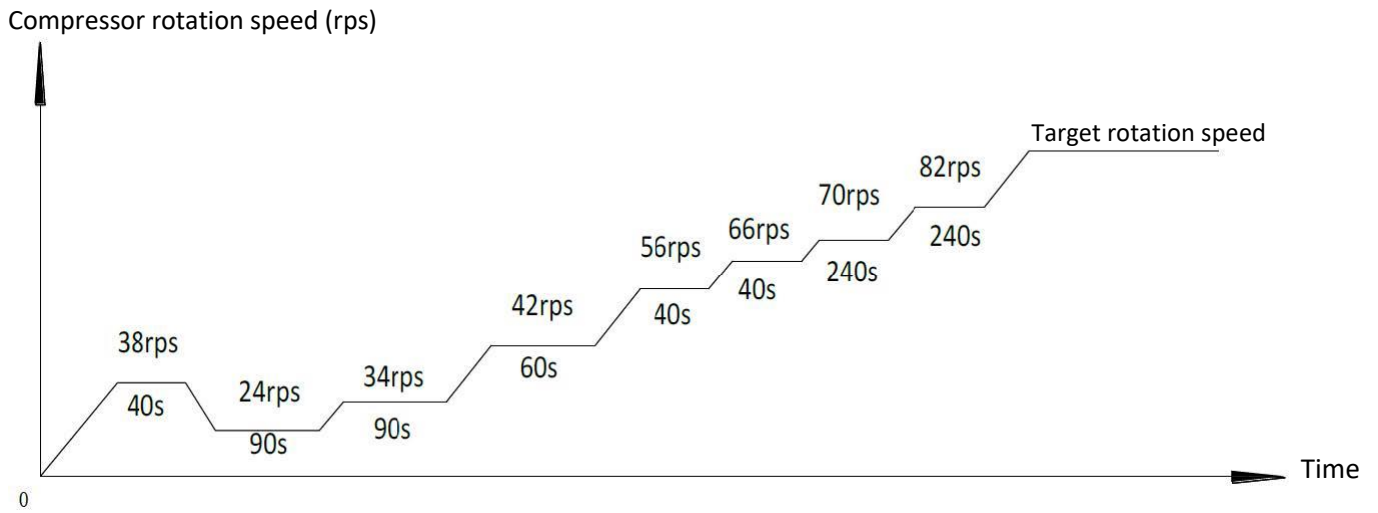

Notes:

1. Once the first, 40-second stage of the program is complete, the program proceeds to the subsequent stages in a step-by-step fashion and exits when the target rotation speed has been reached.

3.3 Startup Control for Heating and Domestic Hot Water Operation

Table 3-3.1: Component control during startup in heating and domestic hot water modes

Component	Wiring diagram label	4-16kW	Control functions and states
DC inverter compressor	COMP	•	Compressor startup program selected according to ambient temperature ¹
Fan	FAN	•	Fan run at maximum speed ²
Electronic expansion valve	EXV	•	Position (steps) from 0 (fully closed) to 480 (fully open), controlled according to outdoor ambient temperature, discharge temperature, suction superheat, compressor speed and refrigeration circuit pressure.
4-way valve	4-WAY	•	On

Notes:

1. Refer to Part 3, 3.2 "Compressor Startup Program".
2. Refer to Table 3-4.3 in Part 3, 4.6 "Outdoor Fan Control".

3.4 Startup Control for Cooling Operation

Table 3-3.2: Component control during startup in cooling mode

Component	Wiring diagram label	4-16kW	Control functions and states
DC inverter compressor	COMP	•	Compressor startup program selected according to ambient temperature ¹
Fan	FAN	•	Fan run at maximum speed ²
Electronic expansion valve	EXV	•	Position (steps) from 0 (fully closed) to 480 (fully open), controlled according to outdoor ambient temperature, discharge temperature, suction superheat, compressor speed and refrigeration circuit pressure.
4-way valve	4-WAY	•	Off

Notes:

1. Refer to Part 3, 3.2 "Compressor Startup Program".
2. Refer to Table 3-4.3 in Part 3, 4.6 "Outdoor Fan Control".

4 Normal Operation Control

4.1 Component Control during Normal Operation

Table 3-4.1: Component control during heating and domestic hot water operations

Component	Wiring diagram label	4-16kW	Control functions and states
DC inverter compressor	COMP	•	Controlled according to load requirement from hydronic system
Fan	FAN	•	Controlled according to outdoor heat exchanger pipe temperature
Electronic expansion valve	EXV	•	Position (steps) from 0 (fully closed) to 480 (fully open), controlled according to outdoor ambient temperature, discharge temperature, suction superheat, compressor speed and refrigeration circuit pressure.
4-way valve	4-WAY	•	On

Table 3-4.2: Component control during cooling operation

Component	Wiring diagram label	4-16kW	Control functions and states
DC inverter compressor	COMP	•	Controlled according to load requirement from hydronic system
Fan	FAN	•	Controlled according to outdoor heat exchanger pipe temperature
Electronic expansion valve	EXV	•	Position (steps) from 0 (fully closed) to 480 (fully open), controlled according to outdoor ambient temperature, discharge temperature, suction superheat, compressor speed and refrigeration circuit pressure.
4-way valve	4-WAY	•	Off

4.2 Compressor Output Control

The compressor rotation speed is controlled according to the load requirement. Before compressor startup, the outdoor unit determines the speed according to outdoor ambient temperature, the set point and actual leaving water temperature. Refer to Part 3, 3.2 “Compressor Startup Program”. Once the startup program is complete, the compressor runs at the target rotation speed. During operation the compressor speed is controlled according to the rate of change in water temperature, the refrigerant pressure and the refrigerant temperature.

4.3 Compressor Step Control

The running speed of six-pole compressors (used on 4-16kW models) in rotations per second (rps) is one third of the frequency (in Hz) of the electrical input to the compressor motor. The frequency of the electrical input to the compressor motors can be altered at a rate of 1Hz per second.

4.4 Four-way Valve Control

The four-way valve is used to change the direction of refrigerant flow through the water side heat exchanger in order to switch between cooling and heating/DHW operations. Refer to Part 2, 3 “Refrigerant flow diagrams”. During heating and DHW operations, the four-way valve is on; during cooling and defrosting operations, the four-way valve is off.

4.5 Electronic Expansion Valve Control

The position of the electronic expansion valve (EXV) is controlled in steps from 0 (fully closed) to 480 (fully open).

- At switch-on:
 - The EXV first closes fully, then moves to the standby position. After a few seconds, the EXV moves to an initial running position, which is determined according to outdoor ambient temperature. After a few minutes, the EXV is controlled according to suction superheat and discharge temperature. Once a few more minutes have elapsed, the EXV is then controlled according to suction superheat, discharge temperature and compressor speed.
- When the outdoor unit is in standby:
 - The EXV is in standby
- When the outdoor unit stops:
 - The EXV first closes completely and then moves to standby.

4.6 Outdoor Fan Control

The speed of the outdoor unit fan is adjusted as shown in Table 3-4.1.

Table 3-4.1: Component control during operation

Fan speed index	Fan speed (rpm)		
	4/6/8/10kW	12/14kW	10kW
W1	200	200	200
W2	250	250	250
W3	300	300	300
W4	350	350	350
W5	400	400	400
W6	450	450	450
W7	500	500	500
W8	530	550	550
W9	550	580	600
W10	580	610	650
W11	600	630	700
W12	600	650	730

5 Protection Control

5.1 High Pressure Protection Control

This control protects the refrigerant circuit from abnormally high pressure and protects the compressor from transient spikes in pressure.

Figure 3-5.1: High pressure protection control

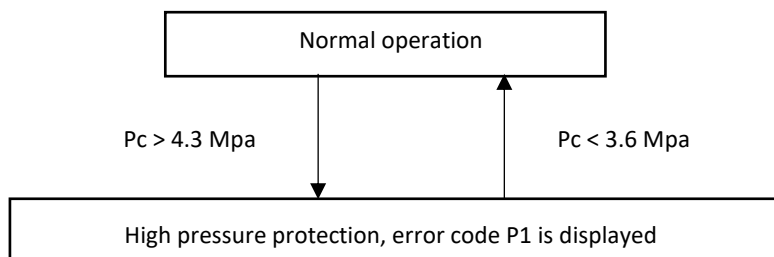

Notes:

- 1 P_c : discharge pressure

When the discharge pressure rises above 4.3 MPa the system displays P1 protection and the unit stops running. When the discharge pressure drops below 3.6 MPa, the compressor enters re-start control.

5.2 Low Pressure Protection Control

This control protects the refrigerant system from abnormally low pressure and protects the compressor from transient drops in pressure.

Figure 3-5.2: Low pressure protection control

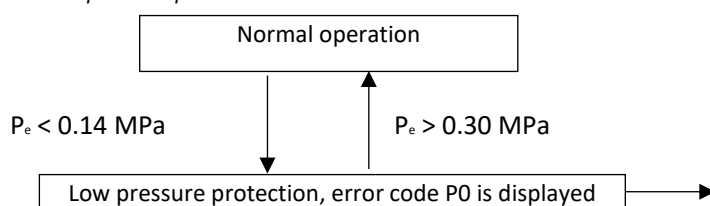

When P0 protection occurs 3 times in 60 minutes, the HP error is displayed. When an HP error occurs, a manual system restart is required before the system can resume operation.

Notes:

- 1 P_e : suction pressure

When the suction pressure drops below 0.14 MPa the system displays P0 protection and the unit stops running. When the suction pressure rises above 0.3 MPa, the compressor enters re-start control.

5.3 Discharge Temperature Protection Control

This control protects the compressor from abnormally high temperatures and transient spikes in temperature.

Figure 3-5.3: High discharge temperature protection control

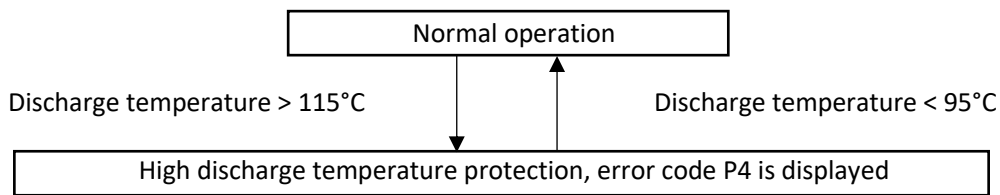

When the discharge temperature rises above 115°C the system displays P4 protection and the unit stops running. When the discharge temperature drops below 95°C, the compressor enters re-start control.

Figure 3-5.4: Low discharge temperature protection control

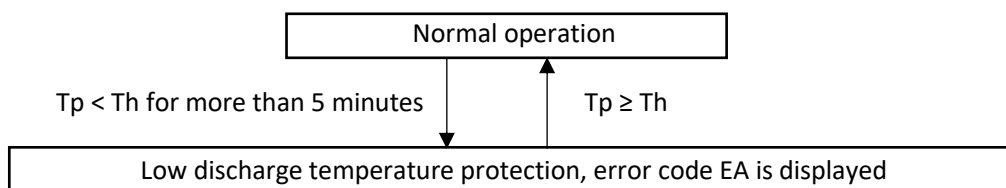

When the discharge temperature (T_p) is below suction temperature (T_h) for more than 5 minutes after compressor operates for 15 minutes, the system displays EA protection and the unit stops running. When the discharge temperature is higher than the suction temperature (T_h), the compressor enters re-start control.

5.4 Compressor Current Protection Control

This control protects the compressor from abnormally high currents.

Figure 3-5.5: Compressor current protection control

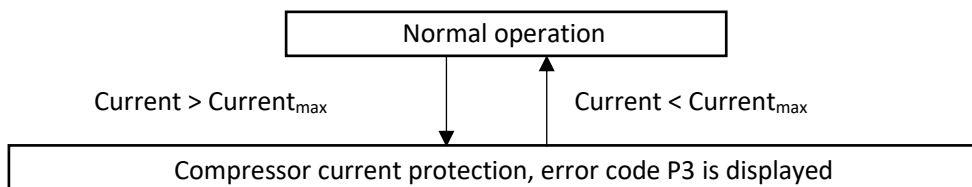

Table 3-5.1: Current limitation for compressors

Model name	MiSAN-YEE 2.1 - 3.1 (1ph)	MiSAN-YEE 4.1 - 5.1 (1ph)	MiSAN-YEE 6.1 - 8.1 (1ph)	MiSAN-YEE 6.1 - 8.1 (3ph)
Compressor model	SVB172FNPMC-L	SVB220FLGMC-L	MUB42FCDMC	MUB4ZFCDMC
Current _{max}	18A	19A	30A	14A

When the compressor current rises above $Current_{max}$ the system displays P3 protection and the unit stops running. When the compressor current drops below $Current_{max}$, the compressor enters re-start control.

5.5 Voltage Protection Control

This control protects the unit from abnormally high or abnormally low voltages.

Figure 3-5.6: Compressor voltage protection control

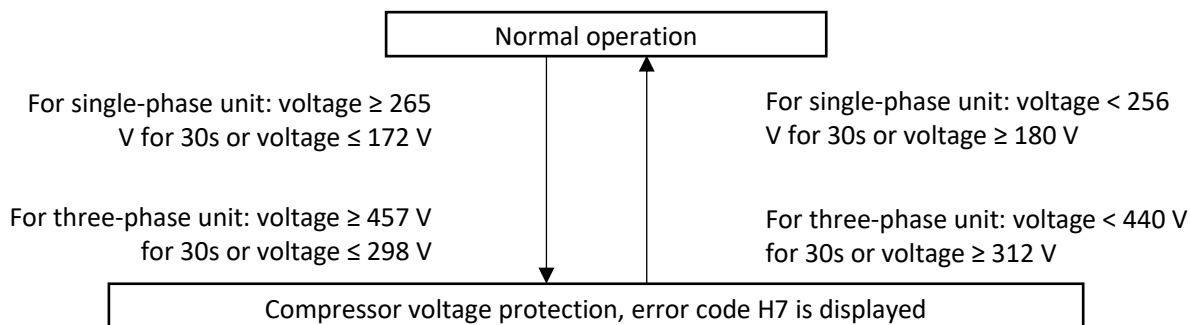

For single-phase unit, when the phase voltage of AC power supply is at or above 265 V for more than 30 seconds, the system displays H7 protection and the unit stops running. When the phase voltage drops below 265 V for more than 30 seconds, the refrigerant circuit restarts once the compressor re-start delay has elapsed. When the phase voltage is below 172 V, the system displays H7 protection and the unit stops running. When the AC voltage rises to more than 180 V, the refrigerant circuit restarts once the compressor re-start delay has elapsed.

For three-phase unit, when the phase voltage of AC power supply is at or above 457 V for more than 30 seconds, the system displays H7 protection and the unit stops running. When the phase voltage drops below 440 V for more than 30 seconds, the refrigerant circuit restarts once the compressor re-start delay has elapsed. When the phase voltage is below 298 V, the system displays H7 protection and the unit stops running. When the AC voltage rises to more than 312 V, the refrigerant circuit restarts once the compressor re-start delay has elapsed.

5.6 DC Fan Motor Protection Control

This control protects the DC fan motors from strong winds and abnormal power supply. DC fan motor protection occurs when any one of the following three sets of conditions are met:

- Outdoor ambient temperature is at or above 4°C and actual fan speed differs from target fan speed by 200 rpm or more for more than 3 minutes.
- Outdoor ambient temperature is below 4°C and actual fan speed differs from target fan speed by 300 rpm or more for more than 3 minutes.
- Actual fan speed is less than 150 rpm for more than 20 seconds.

When DC fan motor protection control occurs the system displays the H6 error code and the unit stops running. After 3 minutes, the unit restarts automatically. When H6 protection occurs 10 times in 120 minutes, the HH error is displayed. When an HH error occurs, a manual system restart is required before the system can resume operation.

5.7 Water Side Heat Exchanger Anti-freeze Protection Control

In cooling mode, if:
entering water temperature
or leaving water temperature
or auxiliary heat source leaving water temperature
is below 4°C, the anti-freeze protection actions.

In heating/DHW mode, if:
ambient temperature is below 3°C
or leaving water temperature is below 2°C
or inlet water temperature
or auxiliary heat source leaving water temperature
is below 5°C, the anti-freeze protection actions.

When water side heat exchanger anti-freeze protection occurs the system displays error code Pb and the unit stops running.

6 Special Control

6.1 Oil Return Operation

In order to prevent the compressor from running out of oil, the oil return operation is conducted to recover oil that has flowed out of the compressor and into the refrigerant piping.

The oil return operation starts when the following condition occurs:

- when the compressor cumulative operating time with running rotation speed less than 42 rps reaches 6 hours.

The oil return operation ceases when any one of the following three conditions occurs:

- oil return operation duration reaches 5 minutes,
- compressor stops.

Tables 3-6.1 show component control during oil return operation in cooling mode.

Component	Wiring diagram label	4-16kW	Control functions and states
DC inverter compressor	COMP	•	Runs at oil return operation rotation speed
Fan	FAN	•	Controlled according to cooling mode
Electronic expansion valve	EXV	•	304 (steps)
4-way valve	4-WAY	•	Off

Tables 3-6.2 show component control during oil return operation in heating and DHW modes.

Component	Wiring diagram label	4-16kW	Control functions and states
DC inverter compressor	COMP	•	Runs at oil return operation rotation speed
Fan	FAN	•	Controlled according to heating mode
Electronic expansion valve	EXV	•	304 (steps)
4-way valve	4-WAY	•	On

6.2 Defrosting operation

In order to recover heating capacity, the defrosting operation is conducted when the outdoor unit air side heat exchanger is performing as an evaporator. The defrosting operation is controlled according to outdoor ambient temperature, air side heat exchanger refrigerant outlet temperature and the compressor running time. Inlet conditions:

- $T_3 < 0^\circ\text{C}$
- $T_4 < -2 \dots -10$ (according to water outlet temperature and time spent in these conditions).

Outlet conditions:

- after 10 minutes of defrosting cycle
- $T_3 > 8^\circ\text{C}$

Table 3-6.3: Component control during defrosting operation

Component	Wiring diagram label	4-16kW	Control functions and states
DC inverter compressor	COMP	•	Runs at defrosting operation rotation speed
Fan	FAN	•	Off
Electronic expansion valve	EXV	•	Fully open (480 steps)
4-way valve	4-WAY	•	Off

6.3 Force Cooling Operation

The force cooling operation helps the refrigerant recovering before removal the water side heat exchanger. The force cool mode can be ended by pushing the button on the outdoor refrigerant system main PCB named "force-cool" for 5s or this mode will be ended automatic if the system has operated force cool mode for more than 30 minutes.

Table 3-6.4: Component control during force cool operation

Component	Wiring diagram label	4-16kW	Control functions and states
DC inverter compressor	COMP	•	Runs at force cooling operation rotation speed
Fan	FAN	•	Runs at force cooling operation speed
Electronic expansion valve	EXV	•	304 (steps)
4-way valve	4-WAY	•	Off

6.4 Fast DHW Operation

Fast DHW operation is used to quickly fulfil a requirement for domestic hot water when DHW priority has been set on the user interface. Refer to installation manual of SPHERA EVO 2.0, Part 10 “Control”.

Table 3-6.5: Component control during fast DHW operation

Component	Wiring diagram label	4-16kW	Control functions and states
DC inverter compressor	COMP	•	Controlled according to load requirement
Fan	FAN	•	Controlled according to outdoor heat exchanger pipe temperature
Electronic expansion valve	EXV	•	Position (steps) from 0 (fully closed) to 480 (fully open), controlled according to discharge superheat
4-way valve	4-WAY	•	On
Electric heater	TBH	•	On

6.5 2 Zone Control

The 2 zone control function is used to control the temperature of each zone separately.

In cooling mode, when the set temperature is reached in one of the two zones, the zone pump switches off.

The same thing happens in the heating mode, with the addition of the control function of the 3-way mixing valve (SV3) which is activated to control the water temperature in the low temperature zone.

The 3-way mixing valve (SV3) will only turn on when the control of the 2 zones is activated.

When the valve turns on, the opening time is controlled according to the temperature difference between that of the supply pipe and the set one.

6.6 Compensation Tank Temperature Control

The compensation tank temperature sensor is used to control switch-on/off of the heat pump. When the heat pump stops, the indoor pump stops to save energy and the compensation tank provides hot water to heat the room. Furthermore, temperature control of the compensation tank allows both room heating and domestic hot water requirements to be fulfilled simultaneously. The compensation tank can store energy to provide hot water while the heat pump runs in heating/cooling mode, which can reduce host selection and initial investment.

6.7 USB Data Transfer

- Convenient programme update

No need to carry heavy equipment; only a USB is needed for program updates of the indoor and outdoor units.

- Transmission of parameter settings between wired controllers

6.8 M1M2 Potential-Free Contact Control

M1M2 can be set in the wired controller for heat pump on/off control, TBH control and DHW control.

- For heat pump on/off control. When the potential-free contact closes for 1s, the heat pump stops. When the potential-free contact opens for 5 seconds, the heat pump switches on/off according to the setting of the wired controller or room thermostat.
- For TBH control, TBH is only controlled by M1M2. If the potential-free contact closes, T5 <65 °C then TBH opens until the water tank temperature reaches 70 °C.
- For DHW control In heating mode, DHW switch-on/off is only controlled by M1M2. In DHW mode, M1M2 control does not affect DHW switch-on/off.

Table 3-7.1: Names of the temperature sensors

Number	Sensor name	Sensor code
1	Suction pipe temperature sensor	Th
2	Discharge pipe temperature sensor	Tp
3	Outdoor ambient temperature sensor	T4
4	Air side heat exchanger refrigerant outlet temperature sensor	T3
5	Water side heat exchanger refrigerant outlet (gas pipe) temperature sensor	T2B
6	Water side heat exchanger refrigerant outlet (liquid pipe) temperature sensor	T2
7	Water side heat exchanger water outlet temperature sensor	Tw_out
8	Water side heat exchanger water inlet temperature sensor	Tw_in
9	Supply water temperature sensor for low-temperature zone (only in case of 2-zone kit)	T1B / Tw2
10	Domestic hot water tank temperature sensor	T5
11	Additional storage temperature sensor	T5_2/Tbt2
12	Water outlet temperature sensor of the backup heater or additional heating source (IBH and/or DHW)	T1
13	Inertial storage temperature sensor (only for cascade function)	Tbt1
14	Solar option temperature sensor	Tsolar

Part 4

Diagnosis and Troubleshooting

1 Electric Control Box Layout	30
2 PCBs	33
3 Error Code Table	47
4 Troubleshooting	49
5 Temperature Sensor Resistance Characteristics	106
6 Control keypad	109

1 Electric Control Box Layout

1.1 Outdoor Unit Electric Control Box Layout

Figura 4-1.1: MiSAN-YEE 1 S 2.1 – 3.1 (single-phase) electric control box

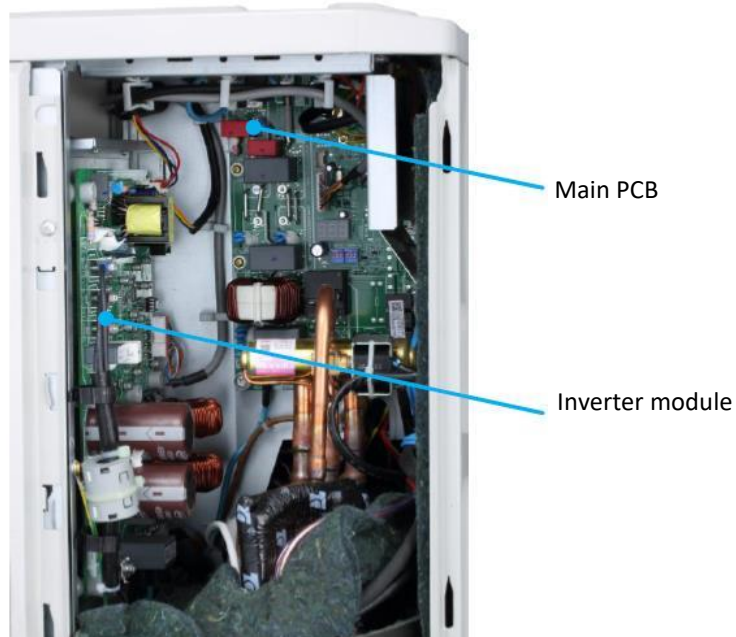

MiSAN-YEE 1 S 4.1 – 5.1 (single-phase) electric control box

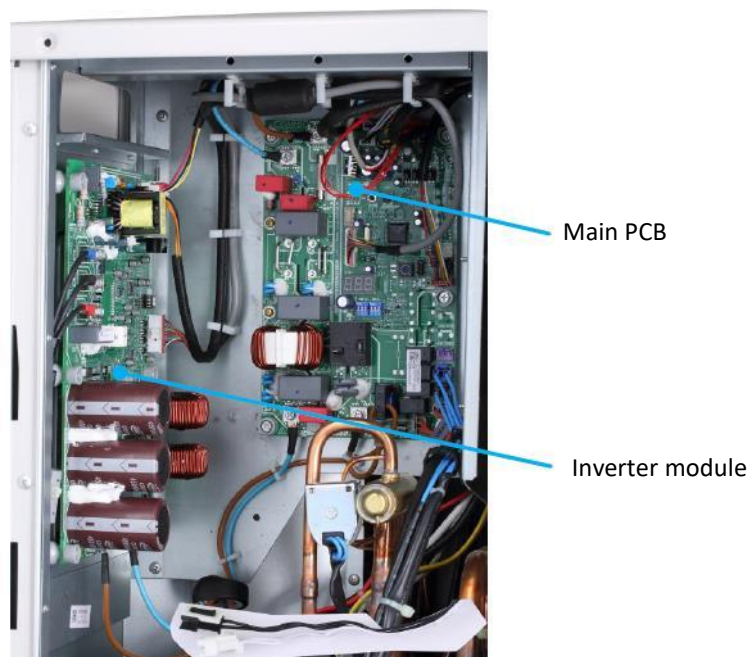

MISAN-YEE 1 S 6.1 – 8.1 (single-phase) electric control box

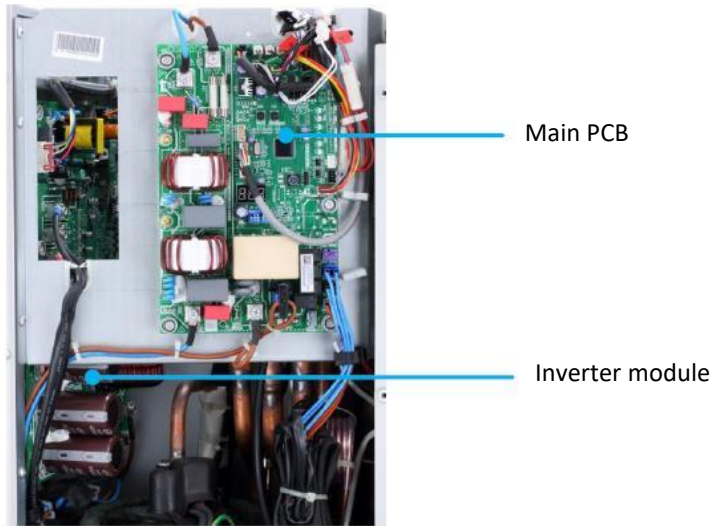

MISAN-YEE 1 S 6.1 – 8.1 (three-phase) electric control box

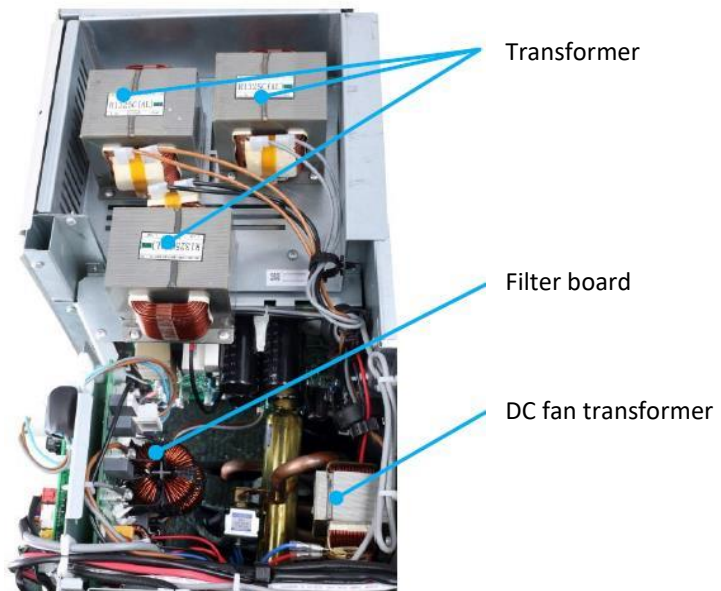
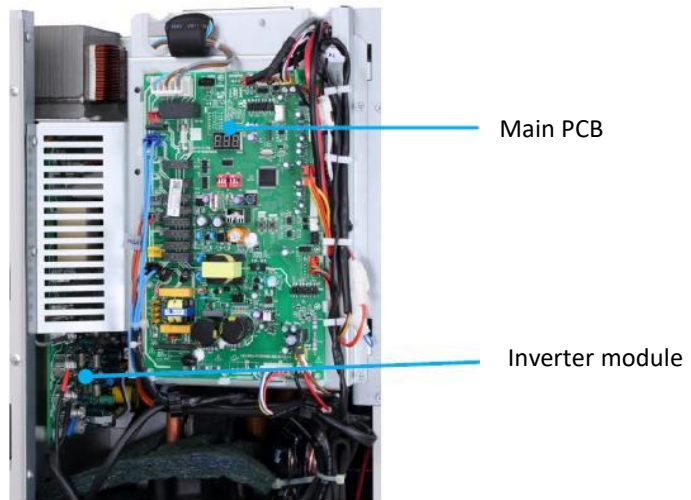

1.2 Indoor Unit Electric Control Box Layout

Figure 4-1.2: Indoor unit electric control box

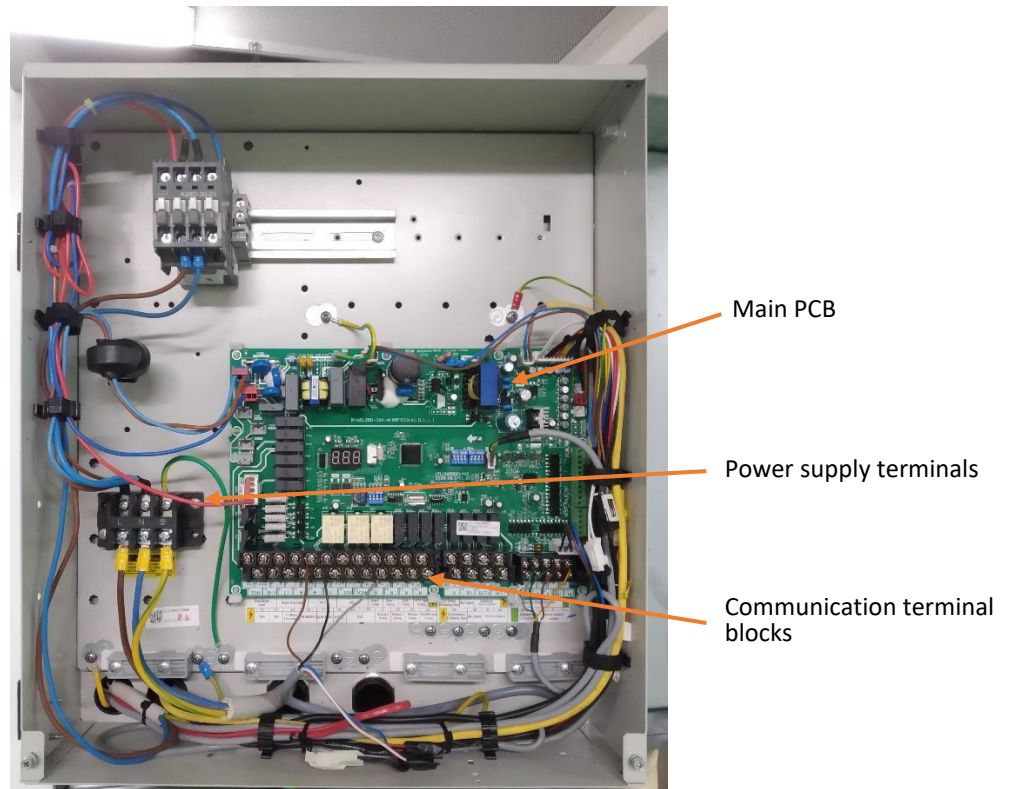

2 PCBs

2.1 Outdoor Unit PCBs

The main PCB is the same for all 4kW to 16kW models. In addition, all models have an inverter module.

The locations of each PCB in the outdoor unit electric control box are shown in Figures 4-1.1 in Part 4, 1.1 "Outdoor Unit Electric Control Box Layout". The locations of each PCB in the indoor unit electric control box are shown in Figures 4-1.2 in Part 4, 1.2 "Indoor Unit Electric Control Box Layout".

2.2 Main PCB for Hydronic System

Figure 4-2.1: Indoor unit main PCB 1

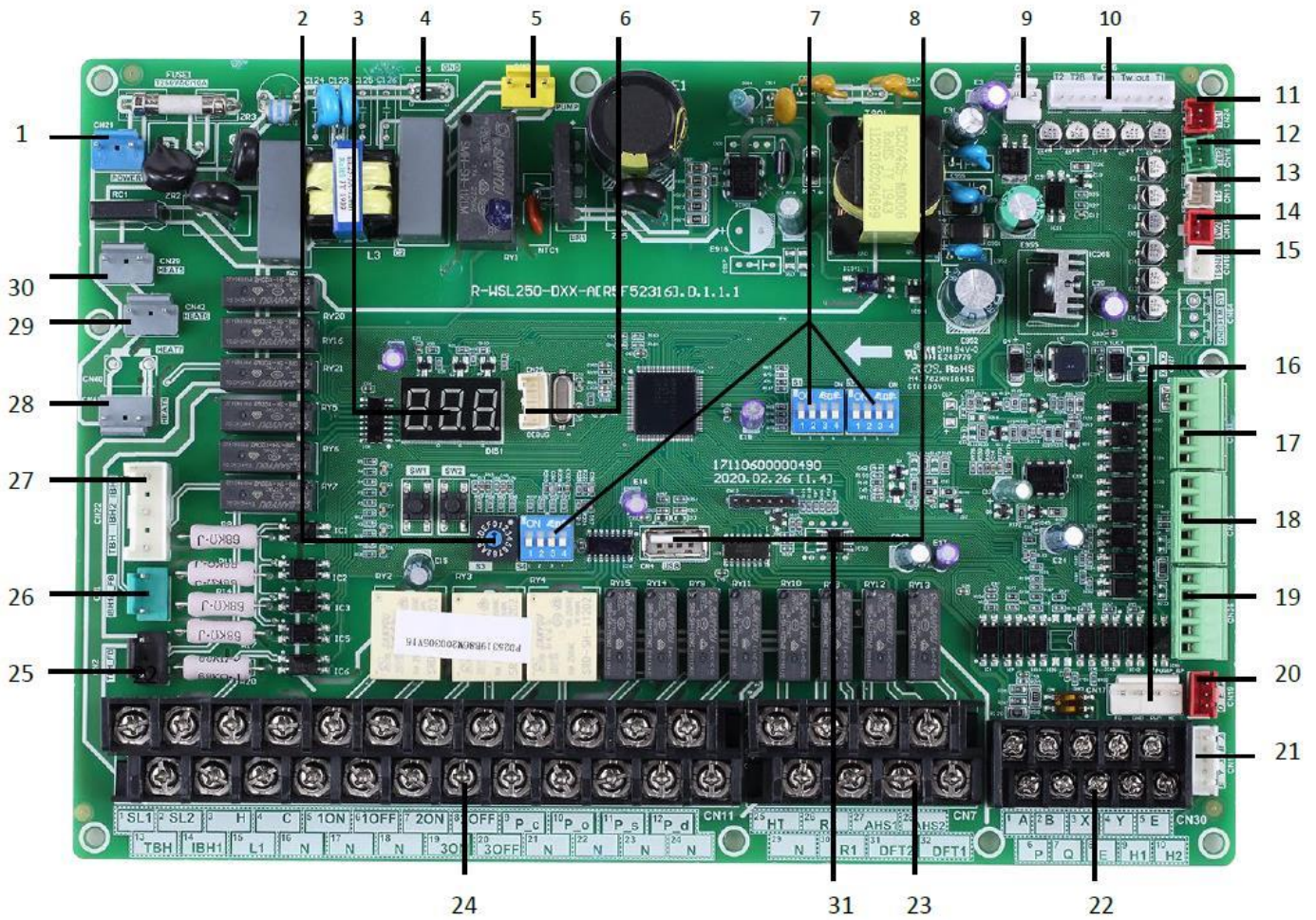

Notes:

1. Label descriptions are given in Table 4-2.1.

Table 4-2.1: Indoor unit main PCB

Label in Figure 4-2.1	Code	Description
1	CN21	Port for power supply
2	S3	Rotary Dip switch
3	DS11	Digital display
4	CN5	Port for GND
5	CN28	Port for variable speed pump power input
6	CN25	Port for IC programming
7	S1,S2,S4	Dip switch
8	CN4	Port for USB programming
9	CN8	Port for flow switch
10	CN6	Port for temperature sensors (T2,T2B,TW_out,TW_in, T1)
11	CN24	Port for temperature sensor (Tbt1, inertial storage temperature probe)
12	CN16	Port for temperature sensor (Tbt2, additional DHW storage temperature probe)
13	CN13	Port for temperature sensor (T5, DHW temperature probe)
14	CN15	Port for temperature sensor (Tw2, only for 2 zones)
15	CN18	Port for temperature sensor (Tsolar, panel temperature probe)
16	CN17	Port for variable speed pump communication
17	CN31	Control port for room thermostat (heating mode) (HT)/ Control port for room thermostat (cooling mode) (CL) / Control port for room thermostat (COM)
18	CN35	Port for smart grid (grid signal, photovoltaic signal)
19	CN36	Port for remote switch, temperature board
20	CN19	Port for communication between indoor unit and outdoor unit
21	CN14	Port for communication with wired controller
22	CN30	Port for communication between indoor unit and outdoor unit, port for communication with wired controller, parallel indoor unit
23	CN7	Port for anti-freeze electric heater (internal), additional heat source, compressor/defrosting operation
24	CN11	Control port for tank booster heater, internal backup heater 1, input port for solar energy, port for room thermostat, SV1 (3-way valve), SV2 (3-way valve), SV3 (3-way valve), zone 2 pump, external circulator, solar energy pump, DHW pipe pump
25	CN2	Feedback port for outdoor temperature switch (shorted in default)
26	CN1	Feedback port for temperature switch (shorted in default)
27	CN22	Control port for backup heater 1/booster heater / reserved
28	CN41	Port for anti-freeze electric heater
29	CN42	Port for anti-freeze electric heater
30	CN29	Port for anti-freeze electric heater
31	IC39	EEPROM

2.3 Main PCBs for Inverter Module

Figure 4-2.2: MiSAN-YEE 1 S 2.1 - 5.1 single-phase outdoor unit 1ph main PCB for refrigerant system1

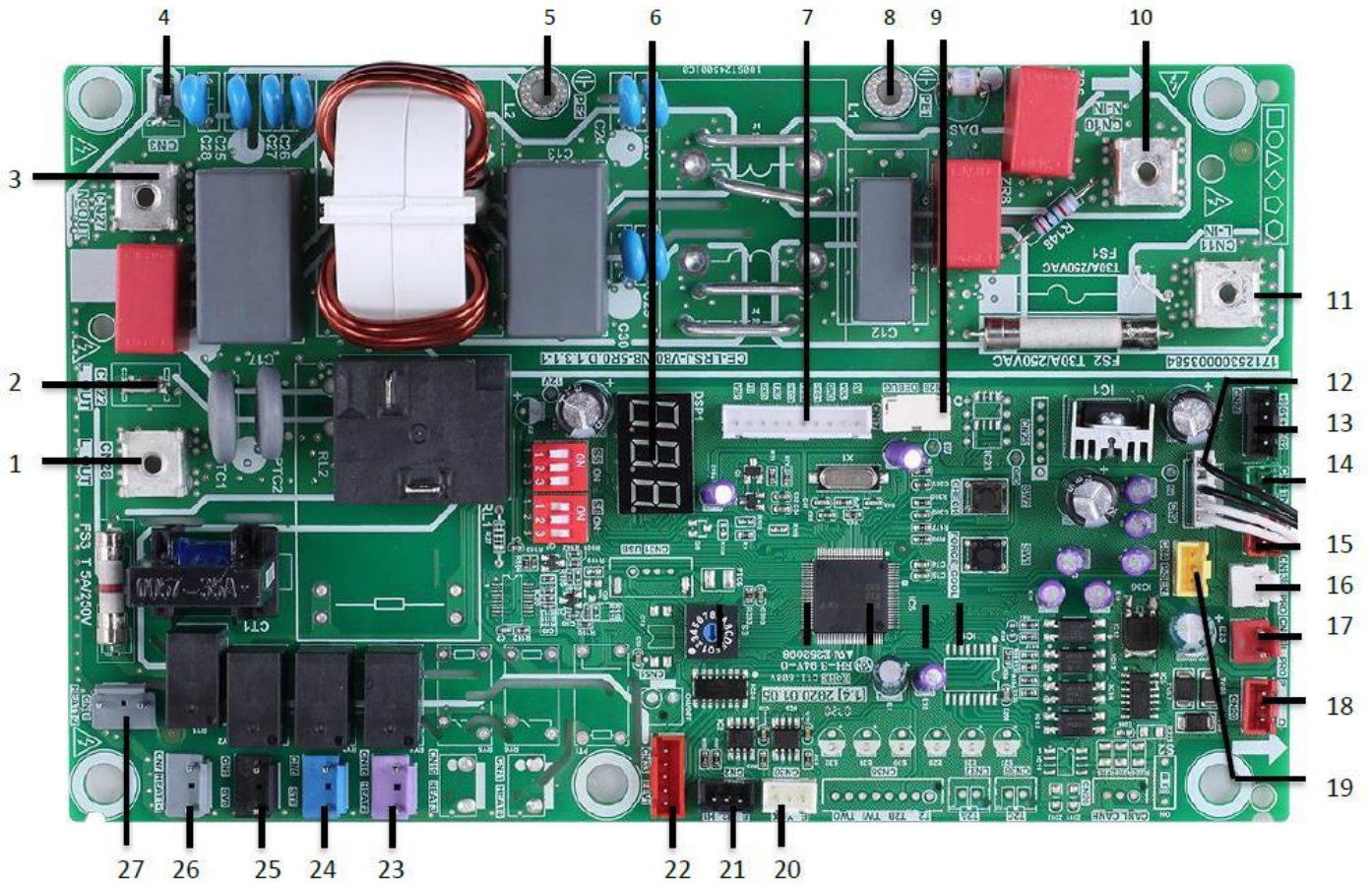

Notes:

1. Label descriptions are given in Table 4-2.2.

Table 4-2.2: MiSAN-YEE 1 S 2.1 - 5.1 single-phase outdoor unit main PCB for refrigerant system

Label in Figure 4-2.2	Code	Description
1	CN28	Output port L to main PCB for refrigerant system
2	CN22	Reserved
3	CN27	Output port N to main PCB for refrigerant system
4	CN3	Reserved
5	PE2	Port for ground wire
6	DSP1	Digital display
7	CN17	Port for communication with PCB for refrigerant system
8	PE1	Port for ground wire
9	CN26	Reserved
10	CN10	Input port for neutral wire
11	CN11	Input port for live wire
12	CN9	Port for outdoor ambient temperature sensor and condenser temperature sensor
13	CN24	Input port for +12V/9V
14	CN1	Port for suction temperature sensor
15	CN8	Port for discharge temperature sensor
16	CN13	Port for HP pressure switch
17	CN14	Port for LP pressure switch
18	CN29	Port for communication with hydro module control board
19	CN4	Port for pressure sensor
20	CN30	Port for communication (Reserved)
21	CN2	Port for communication (Reserved)
22	CN33	Port for electronic expansion valve
23	CN16	Port for drain pan heater
24	CN6	Port for 4-way valve
25	CN5	Port for SV6 valve
26	CN7	Port for compressor electric heater1
27	CN18	Port for compressor electric heater2

Figure 4-2.3: MiSAN-YEE 1 S 6.1 - 8.1 single-phase outdoor unit 1ph main PCB for refrigerant system1

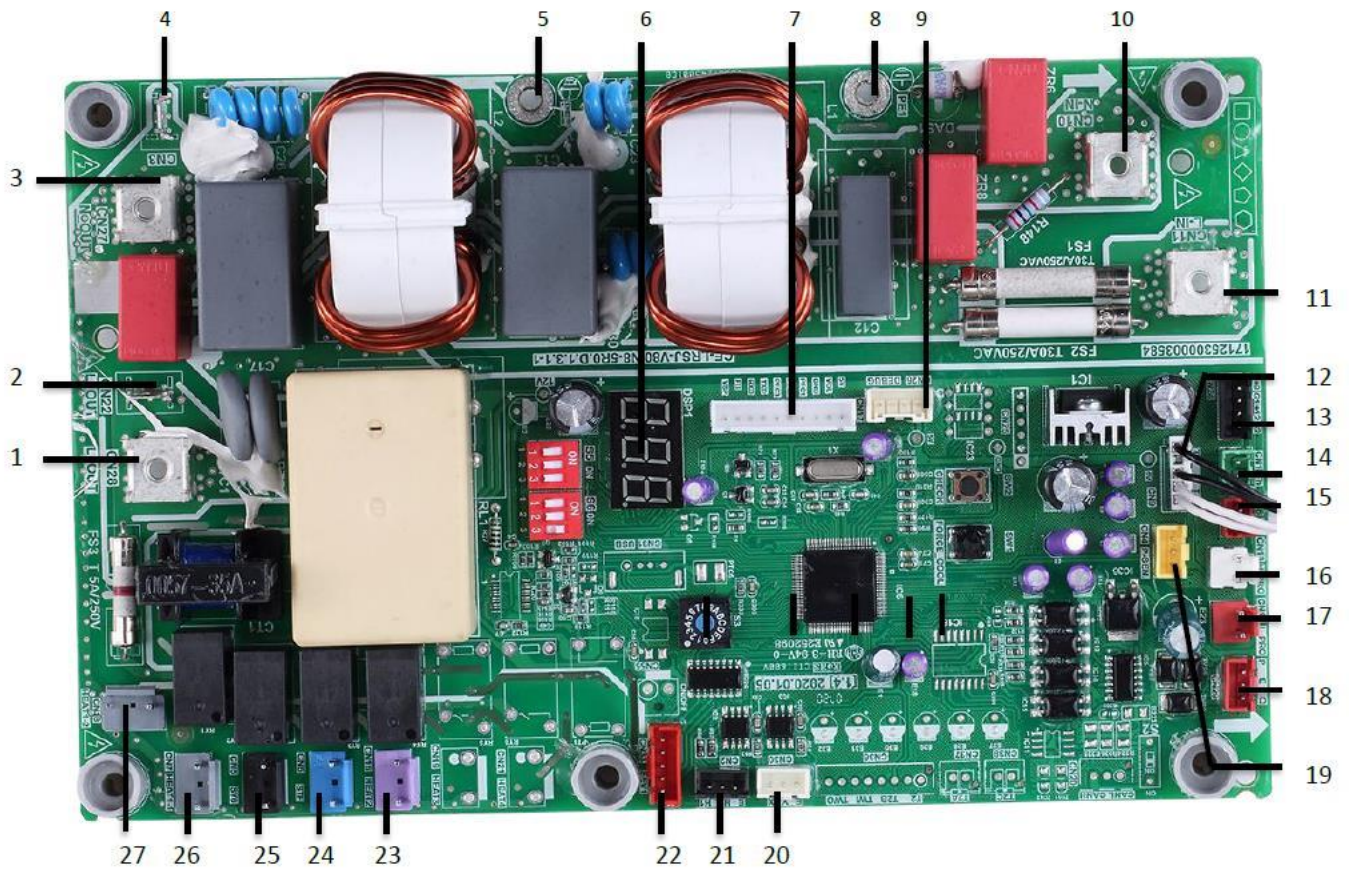

Notes:

1. Label descriptions are given in Table 4-2.3.

Table 4-2.3: MiSAN-YEE 1 S 6.1 - 8.1 single-phase outdoor unit main PCB for refrigerant system

Label in Figure 4-2.3	Code	Description
1	CN28	Output port L to main PCB for refrigerant system
2	CN22	Reserved
3	CN27	Output port N to main PCB for refrigerant system
4	CN3	Reserved
5	PE2	Port for ground wire
6	DSP1	Digital display
7	CN17	Port for communication with PCB for refrigerant system
8	PE1	Port for ground wire
9	CN26	Reserved
10	CN10	Input port for neutral wire
11	CN11	Input port for live wire
12	CN9	Port for outdoor ambient temperature sensor and condenser temperature sensor
13	CN24	Input port for +12V/9V
14	CN1	Port for suction temperature sensor
15	CN8	Port for discharge temperature sensor
16	CN13	Port for HP pressure switch
17	CN14	Port for LP pressure switch
18	CN29	Port for communication with hydro module control board
19	CN4	Port for pressure sensor
20	CN30	Port for communication (Reserved)
21	CN2	Port for communication (Reserved)
22	CN33	Port for electronic expansion valve
23	CN16	Port for drain pan heater
24	CN6	Port for 4-way valve
25	CN5	Port for SV6 valve
26	CN7	Port for compressor electric heater1
27	CN18	Port for compressor electric heater2

Figure 4-2.4: MiSAN-YEE 1 S 6.1 - 8.1 three-phase outdoor unit 3ph main PCB for refrigerant system1

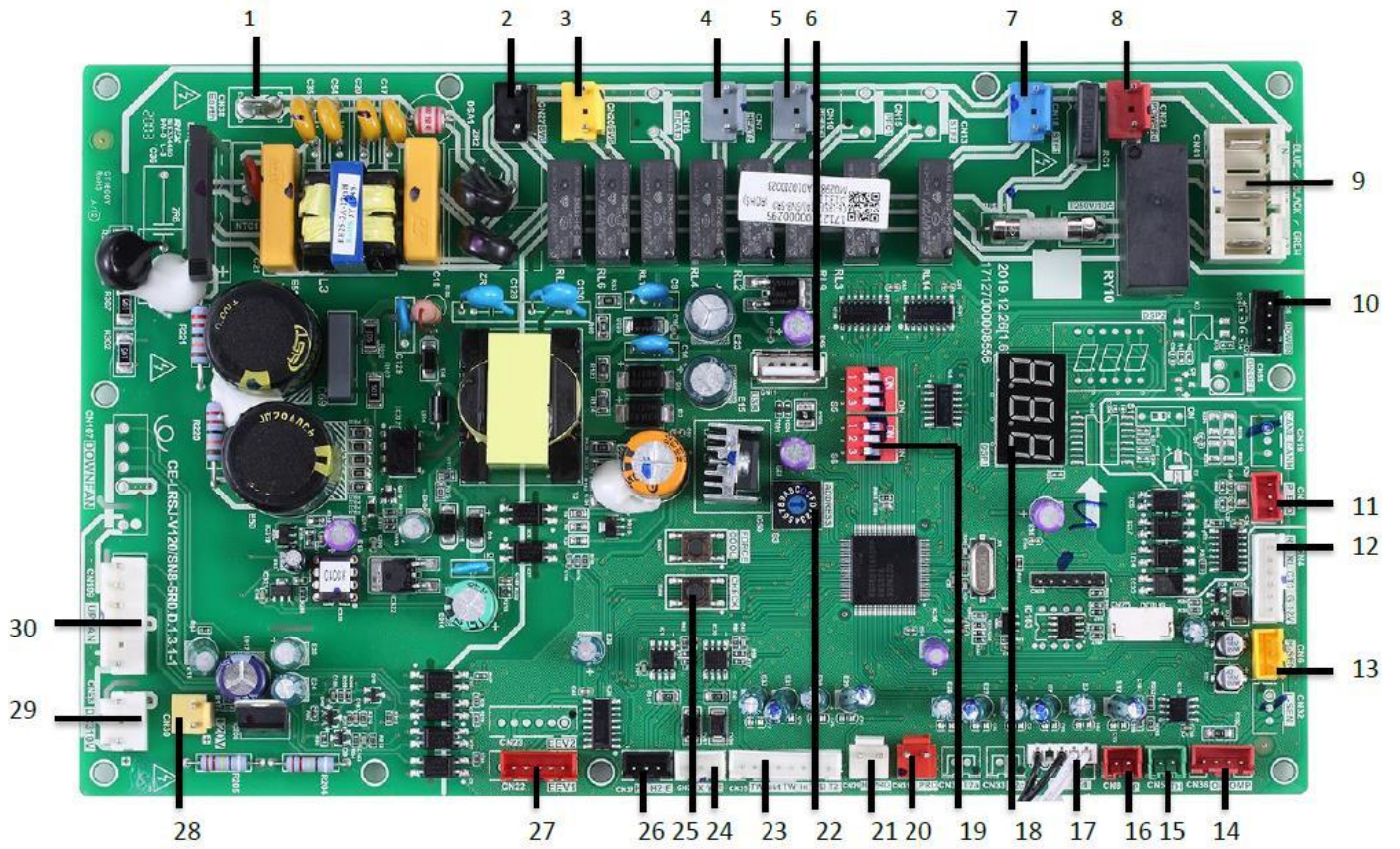

Notes:

1. Label descriptions are given in Table 4-2.4.

Table 4-2.4: MiSAN-YEE 1 S 6.1 - 8.1 three-phase outdoor unit main PCB for refrigerant system

Label in Figure 4-2.4	Code	Description
1	CN38	Port for GND
2	CN27	Port for 2-way valve 6
3	CN20	Port for 2-way valve 5
4	CN7	Port for electric heater 2
5	CN10	Port for electric heater 1
6	CN11	Reserved
7	CN18	Port for 4-way valve
8	CN21	Reserved
9	CN41	Port for power supply from main PCB for inverter module board
10	CN26	Port for communication with Power Meter
11	CN24	Port for communication with hydro module control board
12	CN4	Port for communication with PCB for inverter module board
13	CN6	Port for pressure sensor
14	CN36	Port for communication with PCB for refrigerant system
15	CN5	Port for Th temperature sensor
16	CN8	Port for Tp temperature sensor
17	CN9	Port for outdoor ambient temperature sensor and condenser temperature sensor
18	DSP1	Digital display (DSP1)
19	S5,S6	Dip-switch (S5,S6)
20	CN31	Port for LP pressure switch (CN31)
21	CN29	Port for HP pressure switch and quick control (CN29)
22	S3	Rotary dip switch (S3)
23	CN35	Port for temperature sensors (TW_out,TW_in, T1,T2,T2B)
24	CN28	Port for XYE communication
25	S3,S4	Cold forcing button
26	CN37	Port for H1H2E communication
27	CN22	Port for electronic expansion valve
28	CN30	Port for 15VDC fan power supply
29	CN53	Port for 310VDC fan power supply
30	CN109	Port for fan

Figure 4-2.5: MiSAN-YEE 1 S 2.1 -3.1 single-phase outdoor unit inverter module1

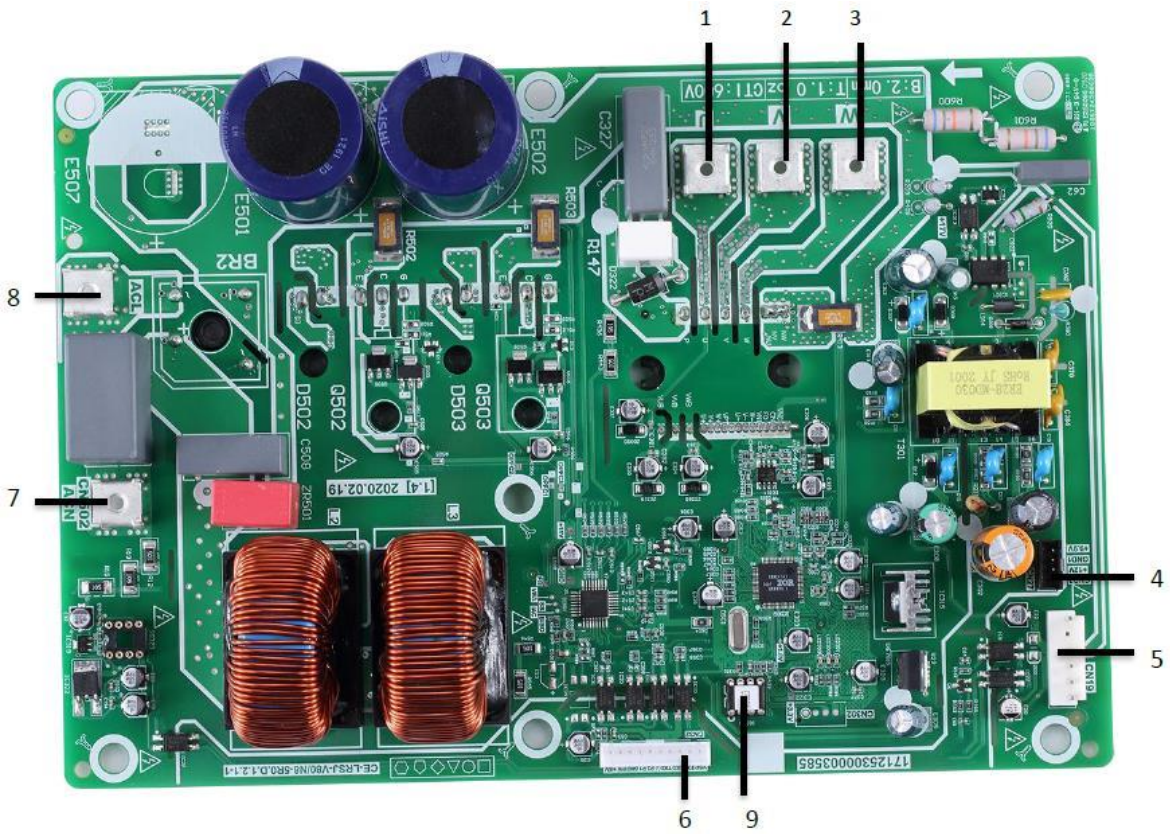

MiSAN-YEE 1 S 4.1 -5.1 single-phase

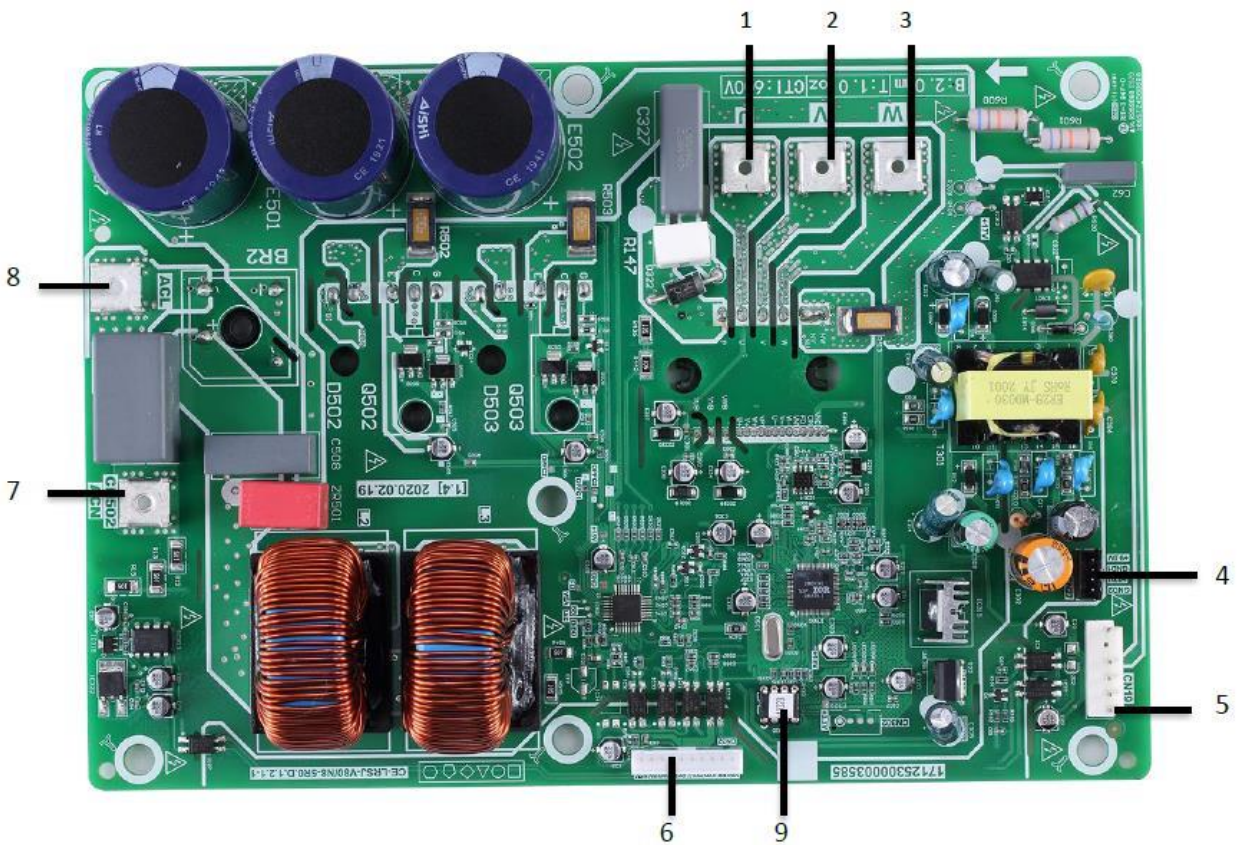

Notes:

1. Label descriptions are given in Table 4-2.5.

Table 4-2.5: Outdoor unit inverter module

Label in Figure 4-2.5	Code	Description
1	U	Compressor connection port U
2	V	Compressor connection port V
3	W	Compressor connection port W
4	CN20	Output port for +12V/9V
5	CN19	Port for fan
6	CN32	Port for communication with main PCB for filter board
7	CN501	Input port L for rectifier bridge
8	CN502	Input port N for rectifier bridge
9	IC320	EEPROM

Figure 4-2.6: MiSAN-YEE 1 S 6.1 -8.1 single-phase outdoor unit inverter module1

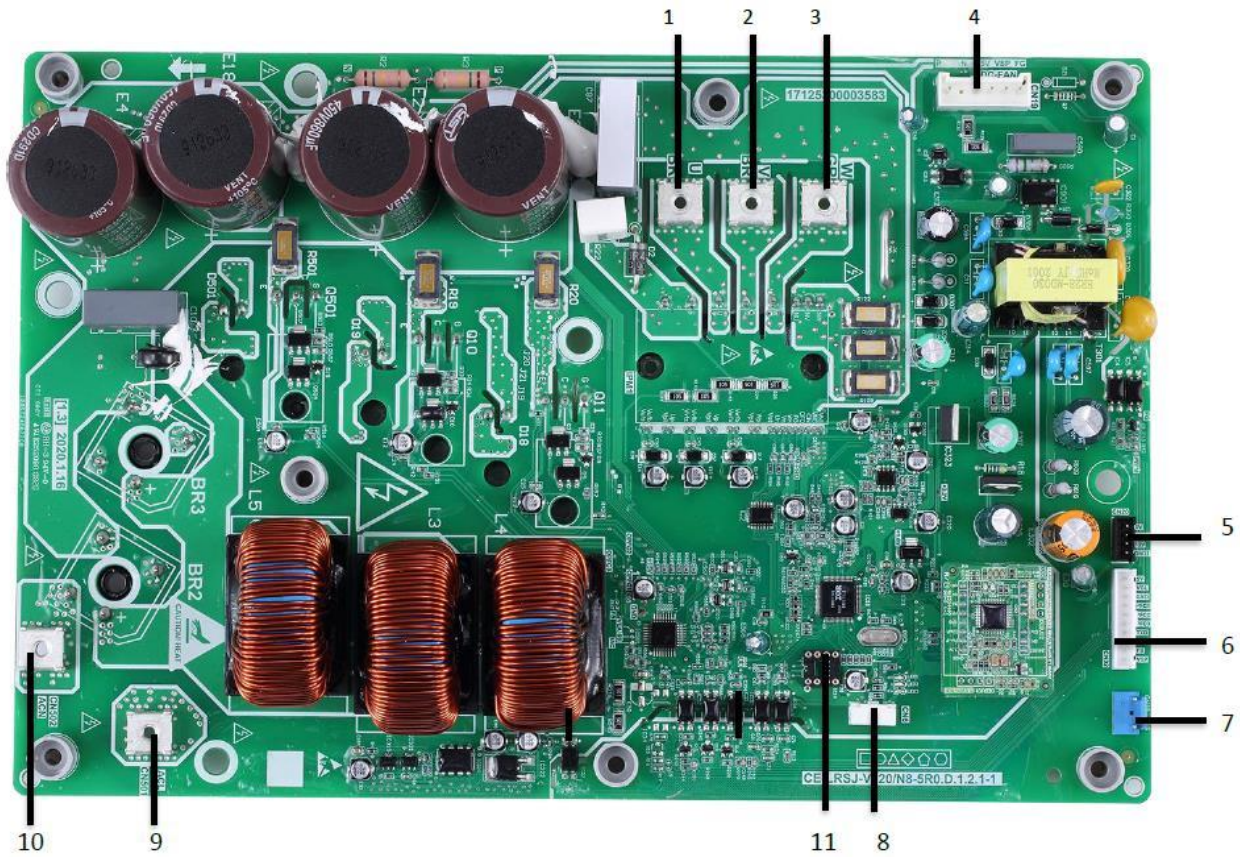

Notes:

1. Label descriptions are given in Table 4-2.6.

Table 4-2.6: Outdoor unit inverter module

Label in Figure 4-2.6	Code	Description
1	U	Compressor connection port U
2	V	Compressor connection port V
3	W	Compressor connection port W
4	CN19	Port for fan
5	CN20	Output port for +12V/9V
6	CN32	Port for communication with main PCB for filter board
7	CN23	Port for HP pressure switch
8	CN6	Reserved
9	CN501	Input port L for rectifier bridge
10	CN502	Input port N for rectifier bridge
11	IC320	EEPROM

Figure 4-2.7: MiSAN-YEE 1 S 6.1 -8.1 three-phase outdoor unit inverter module1

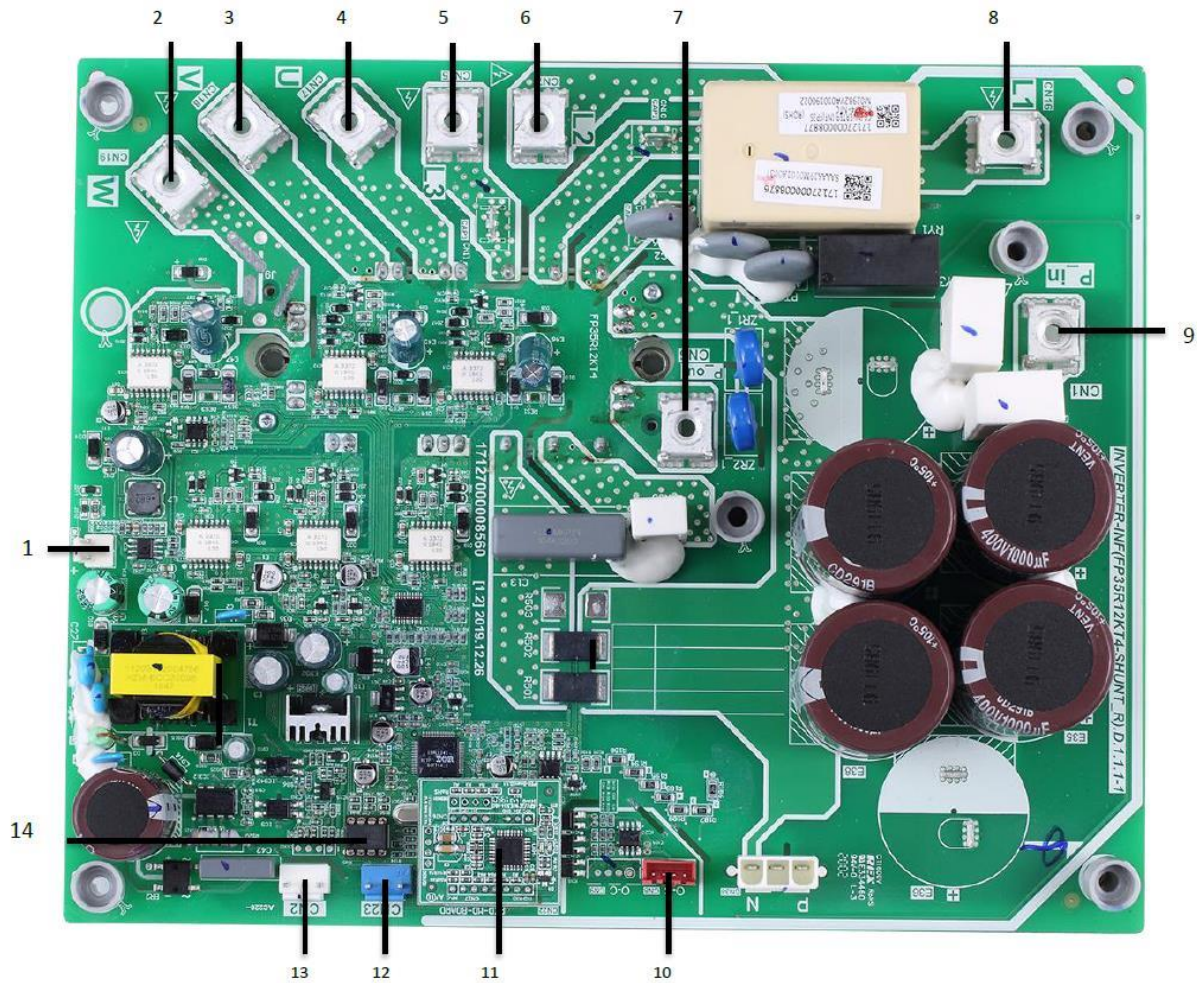

Notes:

1. Label descriptions are given in Table 4-2.7.

Table 4-2.7: Outdoor unit inverter module

Label in Figure 4-2.7	Code	Description
1	CN20	Output port for +15V
2	CN19	Compressor connection port W
3	CN18	Compressor connection port V
4	CN17	Compressor connection port U
5	CN15	Port L3 for power supply input
6	CN7	Port L2 for power supply input
7	CN5	Input port P_out for IPM module
8	CN16	Port L1 for power supply input
9	CN1	Input port P_in for IPM module
10	CN8	Port for communication with main PCB for filter board
11	CN22	PED board
12	CN23	Power supply for HP pressure switch
13	CN2	Port for communication with PCB
14	IC25	EEPROM

Figure 4-2.8: MiSAN-YEE 1 S 6.1-8.1 three-phase outdoor unit filter board1

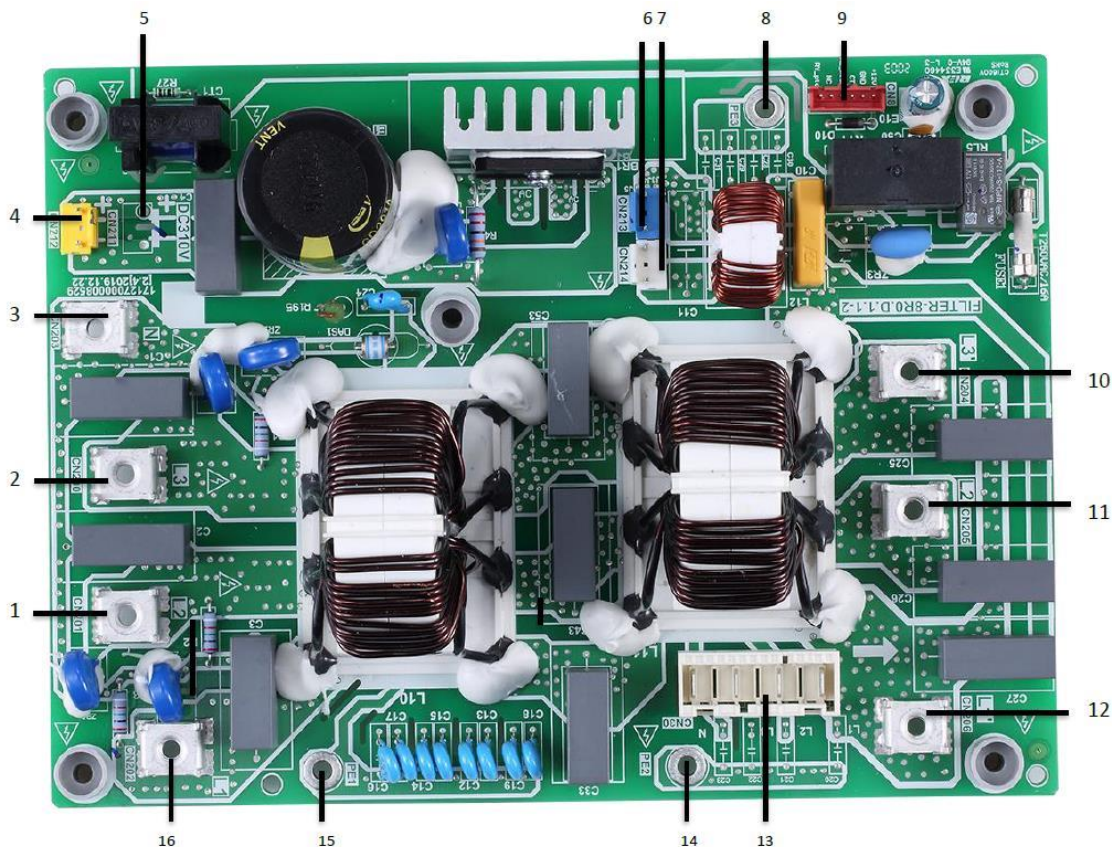

Notes:

1. Label descriptions are given in Table 4-2.8.

Table 4-2.8: Outdoor unit filter board

Label in Figure 4-2.8	Code	Description
1	CN201	L2 power supply
2	CN200	L3 power supply
3	CN203	N power supply
4	CN212	Port for 310VDC power supply
5	CN211	Reserved
6	CN213	Port for fan power supply
7	CN214	Port for inverter module power supply
8	PE3	Port for ground wire
9	CN8	Port for communication with main PCB for filter board
10	L3	Power filtering L3
11	L2	Power filtering L2
12	L1	Power filtering L1
13	CN30	Port for main control board power supply
14	PE2	Port for ground wire
15	PE1	Port for ground wire
16	L1	L1 power supply

2.4 DIP switch setting and wire connecting for Modbus function

The rotating coded switch S3(0-F) on the main control board of hydraulic module is used for setting the Modbus address. By default the units have this coded switch positioned=0, but this corresponds to the Modbus address 16, while the others positions corresponds the number, e.g. pos=2 is address 2, pos=5 is address 5.

Figure 4-2.4: Rotating switch



Figure 4-2.5: Connection

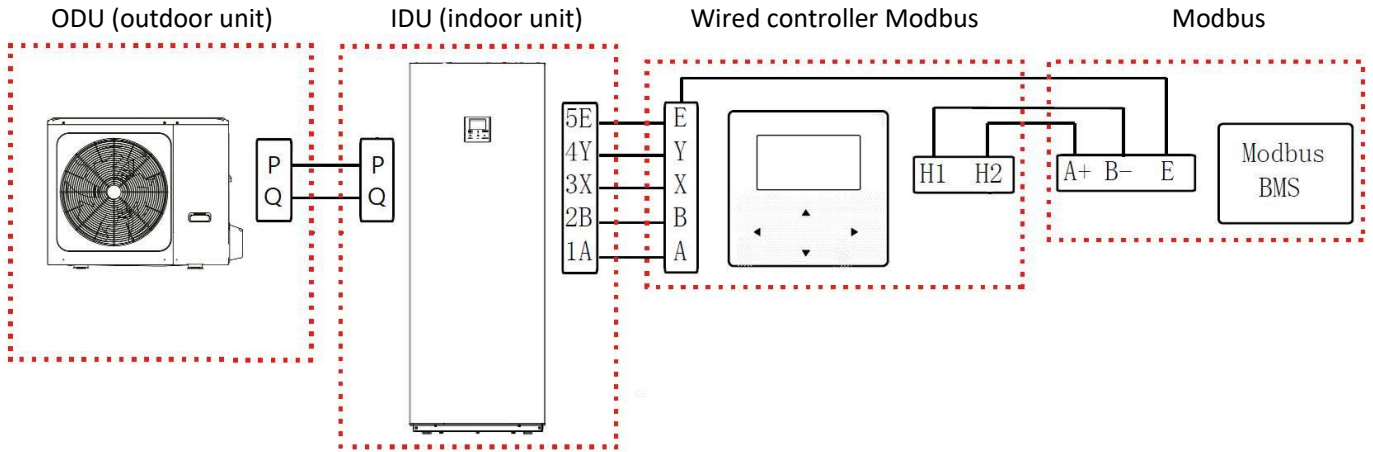
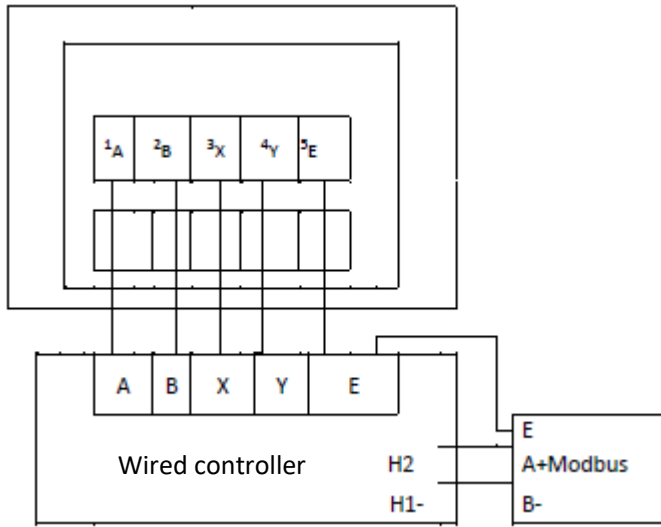

Figure 4-2.6: Wiring



Input voltage (A/B)	13.5 V AC
Wiring size	0.75 mm ²

3 Error Code Table

Error code	Serial number ¹	Content ²	Remarks
C7	65	Transducer module temperature too high	
E0	1	Water flow error (E8 is displayed 3 times)	
E1	2	Phase sequence error	Applies to three-phase models only
E2	3	Communication error between the main control board of hydraulic module and user interface	
E3	4	Leaving water temperature sensor error	T1 sensor
E4	5	Domestic hot water tank temperature sensor error	T5 sensor
E5	6	Air side heat exchanger refrigerant leaving temperature sensor error	T3 sensor
E6	7	Outdoor ambient temperature sensor error	T4 sensor
E7	8	Inertial storage maximum temperature sensor error	Tbt1 sensor
E8	9	Water flow error	
E9	10	Suction pipe temperature sensor error	Th sensor
EA	11	Discharge pipe temperature sensor error	Tp sensor
Eb	12	Solar temperature sensor error	Tsolar sensor
Ec	13	Additional DHW storage temperature sensor error	Tbt2 sensor
Ed	14	Water side heat exchanger water inlet temperature sensor error	Tw_in sensor
EE	15	Hydronic box EEPROM error	
F1	116	DC generatrix voltage is too low	
H0	39	Communication error between outdoor unit main control chip and hydronic box main control chip	
H1	40	Communication error between outdoor unit main control chip and inverter driver chip	
H2	41	Water side plate heat exchanger refrigerant outlet (liquid pipe) temperature sensor error	T2 sensor
H3	42	Water side heat exchanger refrigerant inlet (gas pipe) temperature sensor error	T2B sensor
H4	43	P6 appears 3 times in one hour	
H5	44	Room temperature sensor error (HMI)	Ta sensor
H6	45	DC fan error	
H7	46	Main circuit voltage fault	
H8	47	High pressure sensor error	

H9	48	Circuit 2 water outlet temperature sensor error	Tw2 sensor
HA	49	Water side heat exchanger water outlet temperature sensor error	Tw_out sensor
Hb	50	PP protection appears three times in succession and Twout<7°C	
HF	54	Inverter module EEPROM error	
HH	55	Fan DC error (E6 is displayed 10 times in 120min)	
HP	57	Low pressure protection in cooling mode	
P0	20	Low pressure protection	
P1	21	High pressure protection	
P3	23	Compressor current protection	
P4	24	Discharge temperature protection	
P5	25	High temperature difference between water side heat exchanger water inlet and water outlet temperatures protection	
P6	26	Inverter module protection	
L0	-	Inverter module protection	
L1	-	DC bus low voltage protection	
L2	-	DC bus high voltage protection	
L4	-	MCE error	
L5	-	Zero speed protection	
L7	-	Phase sequence error	
L8	-	Compressor frequency variation greater than 15Hz within one second protection	
L9	-	Actual compressor frequency differs from target frequency by more than 15 Hz protection	
Pb	31	Water side heat exchanger anti-freeze	
Pd	33	High temperature protection of refrigerant outlet temperature of condenser in cooling mode	
PP	38	Water side heat exchanger inlet temperature is higher than outlet temperature in heating mode or DHW mode	
bH	112	PED board error	

4 Troubleshooting

4.1 Warning

Warning



- All electrical work must be carried out by competent and suitably qualified, certified and accredited professionals and in accordance with all applicable legislation (all national, local and other laws, standards, codes, rules, regulations and other legislation that apply in a given situation).
- Switch off the outdoor units before connecting or disconnecting any connections or wiring, otherwise electric shock (which can cause physical injury or death) may occur or damage to components may occur.

4.2 E0, E8 Troubleshooting

4.2.1 Digital display output

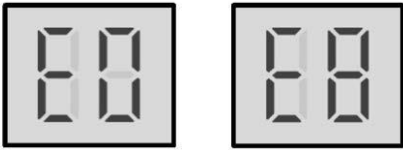

4.2.2 Description

- Water flow error.
- E0 indicates that E8 has been displayed 3 times. When E0 error occurs, a manual system restart is required before the system can resume operation.
- The unit stops running.
- Error code is displayed on indoor unit main PCB and user interface.

4.2.3 Possible causes

- The electric circuit has short-circuited or is open.
- Water flow is insufficient.
- The flow switch is damaged.
- The water circuit has not been properly vented
- The unit pump (Pump_I) does not work

4.2.4 Procedure

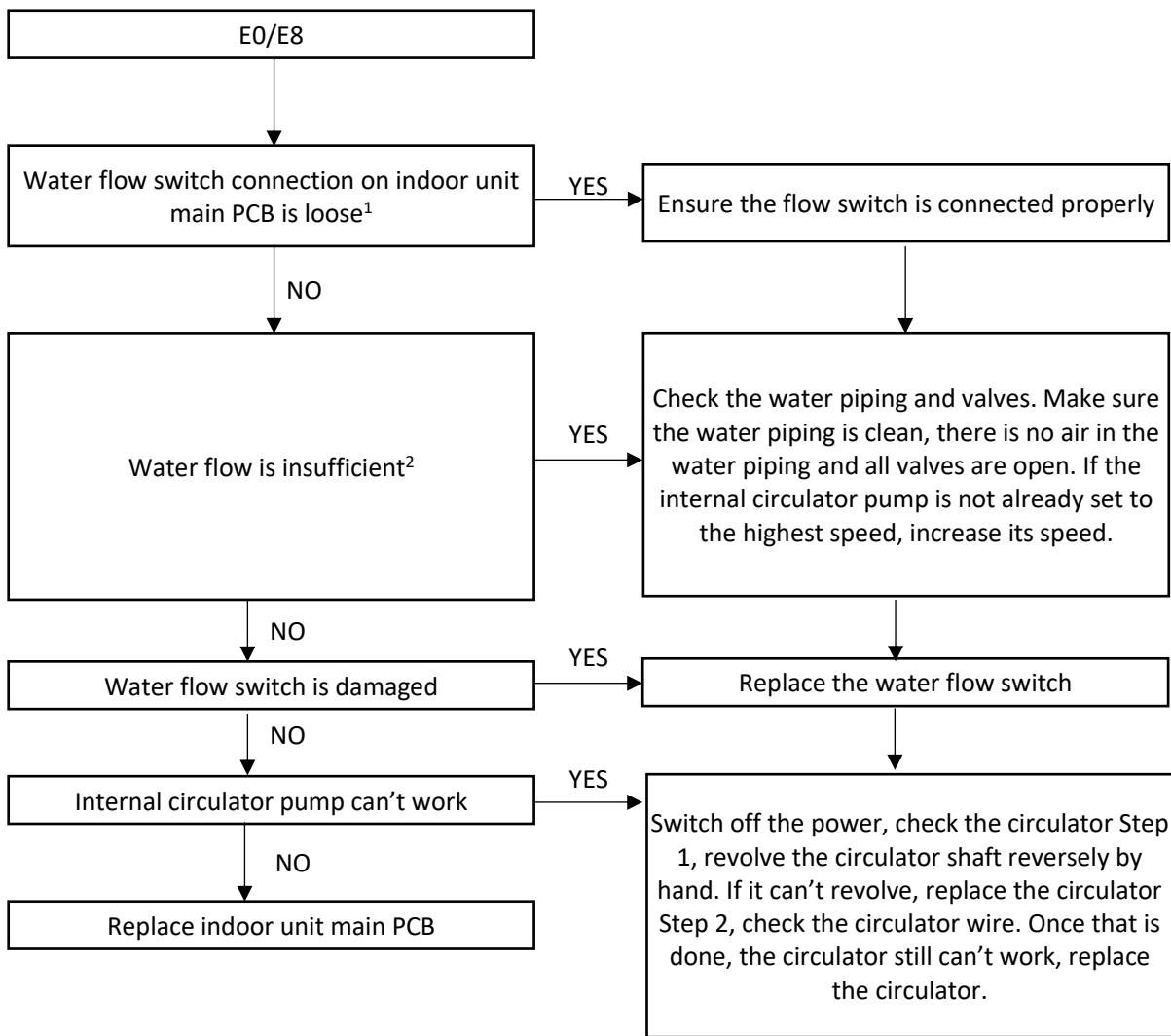

Notes:

1. Water flow switch connection is port CN8 on the main PCB for indoor unit (labelled 6 in Figure 4-2.1 in Part 4, 2.2 "Main PCB for Hydronic System").
2. Check water pressure on the pressure gauge. If the water pressure is not > 1 bar, water flow is insufficient. Refer to Figure 2-1.6 in Part 2, 1 "Indoor Unit Layout".

4.3 E1 Troubleshooting

4.3.1 Digital display output



4.3.2 Description

- Phase sequence error.
- Applies to three-phase models only.
- The unit stops running.
- Error code is displayed on outdoor unit main PCB and user interface.

4.3.3 Possible causes

- Power supply phases not connected in the correct sequence.
- Loosened power supply terminals.
- Abnormal power supply.
- Main PCB is damaged.

4.3.4 Procedure

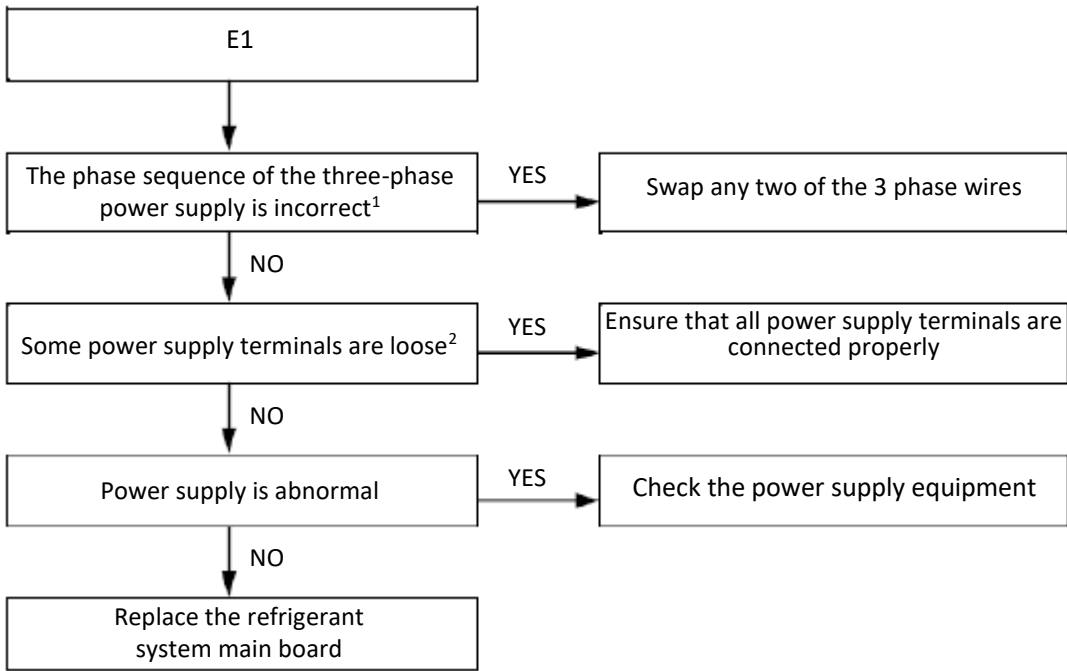

Notes:

1. Terminals A, B, C of the three-phase power supply must correspond to the requirements of the compressor phase sequence. If the phase sequence is reversed, the compressor will operate in reverse. If the wiring connection of each outdoor unit is in the A, B, C phase sequence and more units are connected, the current difference between phase C and phases A and B will be very significant, as the power load of each outdoor unit will be on phase C. In this case it is easy for the circuits to jump and the terminals to burn out. So if more than one unit is to be used, the phase sequence must be staggered so that the current is distributed equally between the three phases.
2. Loose power supply terminals can cause compressors to operate abnormally with very high compressor current.

4.4 E2 Troubleshooting

4.4.1 Digital display output



4.4.2 Description

- Communication error between indoor unit and user interface.
- SPHERA EVO stops running.
- Error code is displayed on indoor unit main PCB and user interface.

4.4.3 Possible causes

- Communication wires between indoor unit and user interface not connected properly.
- Communication wiring X Y E terminals disconnected.
- Loosened wiring inside the electric control box.
- Interference from high voltage wires or other sources of electromagnetic radiation.
- Damaged main PCB or electric control box communication terminals block.

4.4.4 Procedure

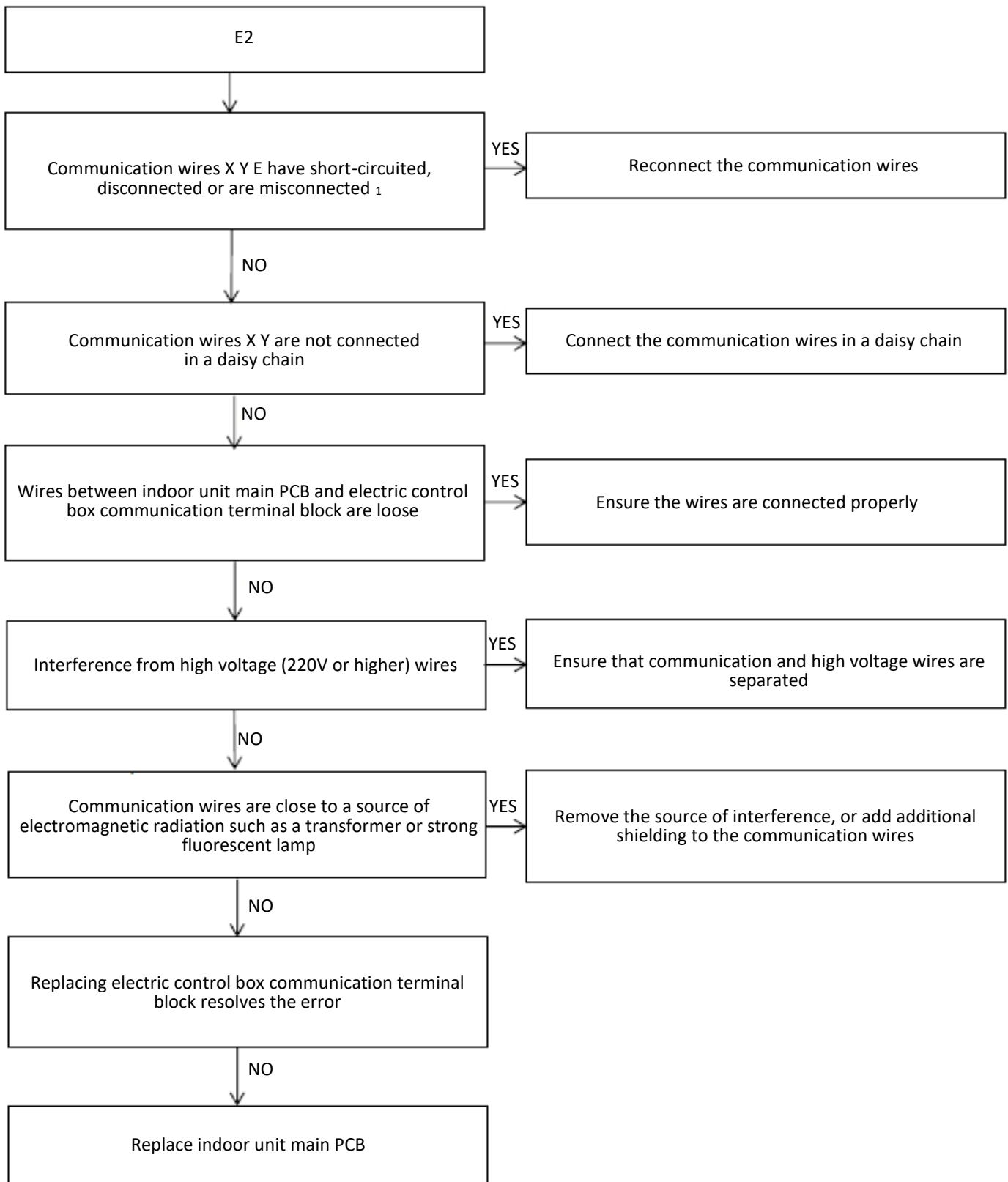

Notes:

1. Measure the resistance between X, Y. The normal resistance between P and Q is 120Ω.
Communication wiring has polarity. Ensure that the X wire is connected to X terminals and the Y wire is connected to Y terminals.

4.5 E3, E4, H3, Ed, HA, H5, H9, Eb, E7, Ec Troubleshooting

4.5.1 Digital display output

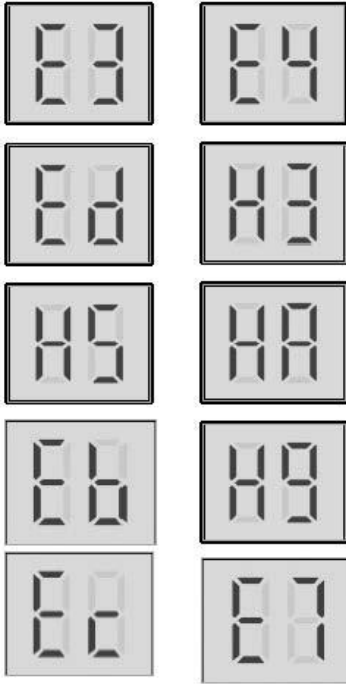

4.5.2 Description

- E3 indicates a backup electric heater water outlet temperature sensor error (T1)
- E4 indicates a domestic hot water tank temperature sensor error (T5)
- H3 indicates a water side heat exchanger refrigerant inlet (liquid pipe) temperature sensor error (T2)
- Ed indicates a water side heat exchanger water inlet temperature sensor error (Tw_in)
- HA indicates a water side heat exchanger water outlet temperature sensor error (Tw_out)
- H5 indicates a room temperature sensor error (Ta)
- H9 indicates a low temperature circuit water outlet temperature sensor error (T1B)
- Eb indicates a solar option temperature sensor error (Tsolar)
- E7 indicates an inertial storage temperature sensor error (Tbt1)
- Ec indicates an additional DHW storage temperature sensor error (T5_2/Tbt2)
- The unit stops running.
- Error code is displayed on indoor unit main PCB and user interface.

4.5.3 Possible causes

- Temperature sensor not connected properly or has malfunctioned.
- Damaged indoor unit main PCB.

4.5.4 Procedure

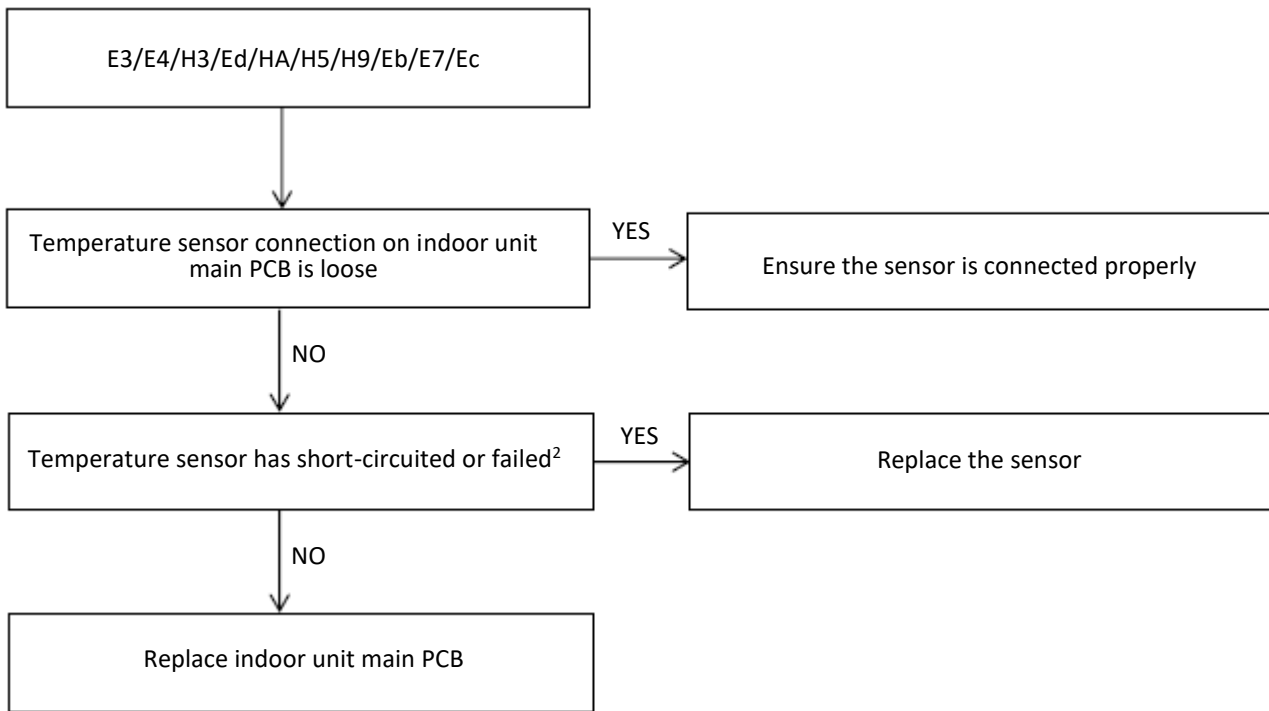

Notes:

1. End water outlet temperature sensor, water side heat exchanger refrigerant inlet (liquid pipe) temperature sensor, water side heat exchanger refrigerant outlet (gas pipe) temperature sensor, water side heat exchanger water inlet temperature sensor and water side heat exchanger water outlet temperature sensor connections are port CN6 on the indoor unit main PCB (labelled 10 in Figure 4-2.1 in Part 4, 2.2 "Main Board for Hydronic System"). Domestic hot water tank temperature sensor connection is port CN13 on the indoor unit main PCB (labelled 13 in Figure 4-2.1 in Part 4, 2.2 "Main Board for Hydronic System"). Circuit 2 water outlet temperature sensor connection is port CN15 on the indoor unit main PCB (labelled 14 in Figure 4-2.1 in Part 4, 2.2 "Main Board for Hydronic System"). Ambient temperature sensor connection is port CN11 on the indoor unit main PCB (labelled 24 in Figure 4-2.1, in Part 4, 2.2 "Main Board for Hydronic System"). Solar panel temperature sensor connection is port CN18 on the indoor unit main PCB (labelled 15 in Figure 4-2.1 in Part 4, 2.2 "Main Board for Hydronic System"). Inertial storage temperature sensor connection is port CN24 on the indoor unit main PCB (labelled 11 in Figure 4-2.1 in Part 4, 2.2 "Main Board for Hydronic System"). Additional DHW storage temperature sensor connection is port CN16 on the indoor unit main PCB (labelled 12 in Figure 4-2.1 in Part 4, 2.2 "Main Board for Hydronic System").
2. Measure sensor resistance. If the resistance is too low, the sensor has short-circuited. If the resistance is not consistent with the sensor's resistance characteristics table, the sensor has failed. Refer to Table 4-5.1 or 4-5.3 in Part 4, 5.1 "Temperature Sensor Resistance Characteristics".

4.6 E5, E6, E9, EA Troubleshooting

4.6.1 Digital display output

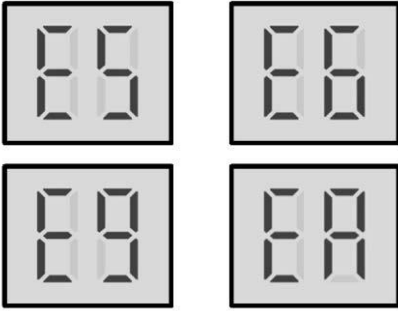

4.6.2 Description

- E5 indicates an air side heat exchanger refrigerant outlet temperature sensor error.
- E6 indicates an outdoor ambient temperature sensor error.
- E9 indicates a suction pipe temperature sensor error.
- EA indicates a discharge temperature sensor error.
- The unit stops running.
- Error code is displayed on outdoor unit main PCB and user interface.

4.6.3 Possible causes

- Temperature sensor not connected properly or has malfunctioned.
- Outdoor unit main PCB damaged.

4.6.4 Procedure

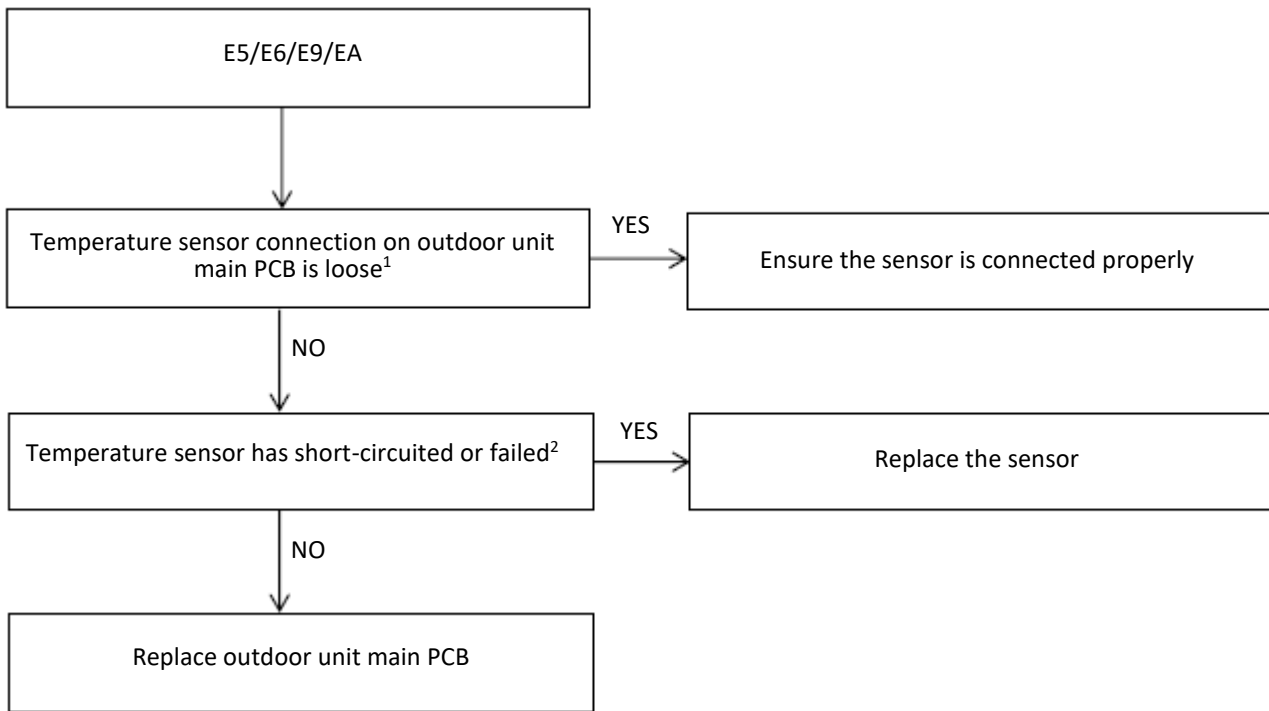

Notes:

1. Air side heat exchanger refrigerant outlet temperature sensor and outdoor ambient temperature sensor connections are port CN9 on the outdoor unit main PCB MiSAN-YEE 1 S 2.1-5.1 single-phase (labelled 12 in Figure 4-2.2 in Part 4, 2.1 "Main PCBs for Refrigerant System, Inverter Module"), port CN9 on the outdoor unit main PCB MiSAN-YEE 1 S 6.1-8.1 single-phase (labelled 12 in Figure 4- 2.3 in Part 4, 2.1 "Main PCBs for Refrigerant System, Inverter Module"), port CN9 on the outdoor unit main PCB MiSAN-YEE 1 S 6.1-8.1 three-phase (labelled 14 in Figure 4-2.4 in Part 4, 2.1 "Main PCBs for Refrigerant System, Inverter Module"). Discharge pipe temperature sensor connection is port CN8 on the outdoor unit main PCB MiSAN-YEE 1 S 2.1-5.1 single-phase (labelled 15 in Figure 4-2.2 in Part 4, 2.1 "Main PCBs for Refrigerant System, Inverter Module"), port CN8 on the outdoor unit main PCB MiSAN-YEE 1 S 6.1-8.1 single-phase (labelled 15 in Figure 4-2.3 in Part 4, 2.1 "Main PCBs for Refrigerant System, Inverter Module"), port CN4 on the outdoor unit main PCB MiSAN-YEE 1 S 6.1-8.1 three-phase (labelled 15 in Figure 4-2.4 in Part 4, 2.1 "Main PCBs for Refrigerant System, Inverter Module"), port CN1 on the outdoor unit main PCB MiSAN-YEE 1 S 2.1-5.1 single-phase (labelled 14 in Figure 4-2.2 in Part 4, 2.1 "Main PCBs for Refrigerant System, Inverter Module"), port CN1 on the outdoor unit main PCB MiSAN-YEE 1 S 6.1-8.1 single-phase (labelled with 14 in Figure 4-2.3 in Part 4, 2.1 "Main PCBs for Refrigerant System, Inverter Module"), port CN8 on the outdoor unit main PCB MiSAN-YEE 1 S 6.1-8.1 three-phase (labelled 16 in Figure 4-2.4 in Part 4, 2.1 "Main PCBs for Refrigerant System, Inverter Module")
2. Measure sensor resistance. If the resistance is too low, the sensor has short-circuited. If the resistance is not consistent with the sensor's resistance characteristics table, the sensor has failed. Refer to Table 4-5.1, and Table 4-5.2 in Part 4, 5.1 "Temperature Sensor Resistance Characteristics".

4.7 EE Troubleshooting

4.7.1 Digital display output



4.7.2 Description

- Indoor unit main PCB EEPROM error.
- The unit stops running.
- Error code is displayed on indoor unit main PCB and user interface.

4.7.3 Possible causes

- Indoor unit main PCB EEPROM is not connected properly.
- Damaged indoor unit main PCB.

4.7.4 Procedure

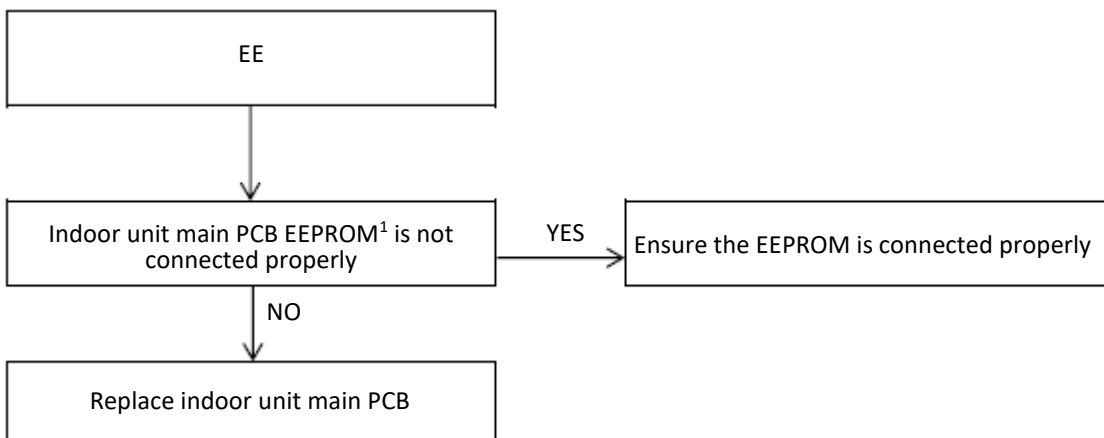

Notes:

1. Indoor unit main PCB EEPROM is designated IC18 on the main PCB for indoor unit (labelled 32 in Figure 4-2.1 in Part 4, 2.2 "Main PCB for Hydronic System").

4.8 F1 Troubleshooting

4.8.1 Digital display output



4.8.2 Description

- Low DC generatrix voltage.
- The unit stops running.
- Error code is displayed on indoor unit main PCB and user interface.

4.8.3 Possible causes

- The DC generatrix voltage is too low

4.8.4 Procedure

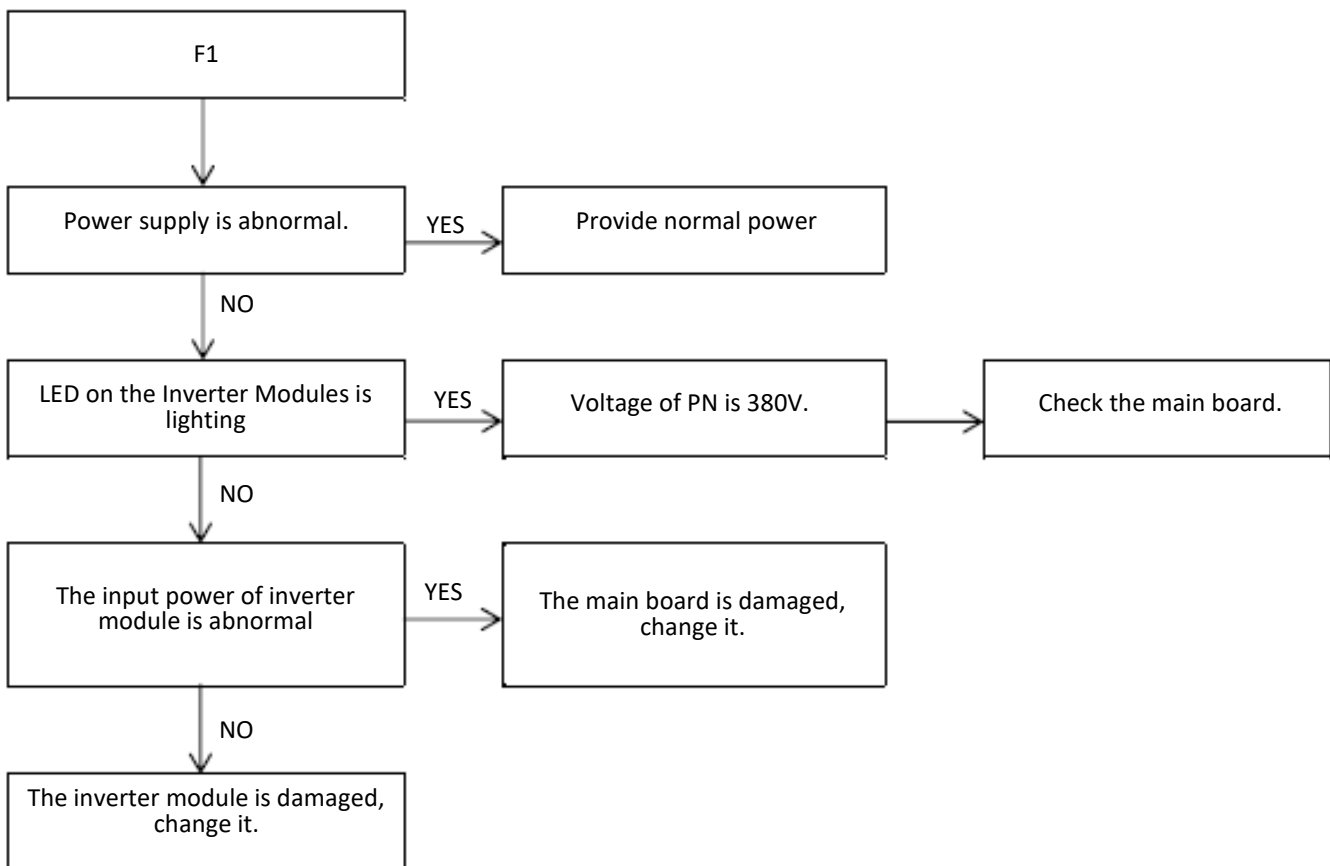

4.9 HF Troubleshooting

4.9.1 Digital display output

4.9.2 Description

- Outdoor unit main PCB EEPROM error.
- The unit stops running.
- Error code is displayed on outdoor unit main PCB and user interface.

4.9.3 Possible causes

- Outdoor unit main PCB EEPROM is not connected properly.
- Outdoor unit main PCB is damaged.

4.9.4 Procedure

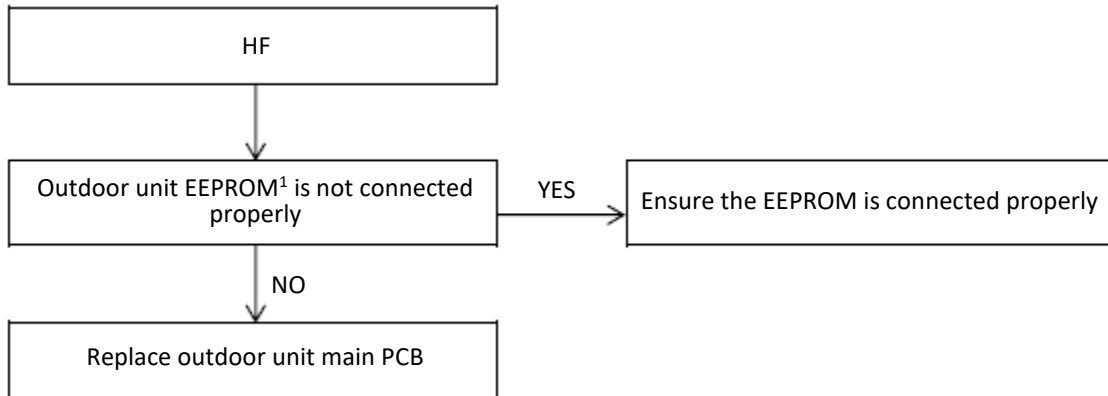

Notes:

1. Outdoor unit inverter EEPROM is designated IC320 on the single-phase outdoor unit MiSAN-YEE 1 S. 2.1-5.1 outdoor unit inverter module (labelled 9 in Figure 4-2.5 in Part 4, 2.3 "Main PCB for Refrigerant System, Inverter Module"), designated IC14 on the single-phase outdoor unit MiSAN-YEE 1 S 6.1-8.1 outdoor unit inverter module (labelled 11 in Figure 4-2.6 in Part 4, 2.3 "Main PCB for Refrigerant System, Inverter Module"), designated IC25 on the three-phase outdoor unit MiSAN-YEE 1 S 6.1-8.1 outdoor unit inverter module (labelled 14 in Figure 4-2.7 in Part 4, 2.3 "Main PCB for Refrigerant System, Inverter Module").

4.10 H0 Troubleshooting

4.10.1 Digital display output



4.10.2 Description

- Communication error between outdoor unit and indoor unit.
- The unit stops running.
- Error code is displayed on indoor unit main PCB, outdoor unit main PCB and user interface.

4.10.3 Possible causes

- Abnormal power supply.
- Transformer malfunction.
- Interference from a source of electromagnetic radiation.
- Outdoor unit main PCB or indoor unit damaged.

4.10.4 Procedure

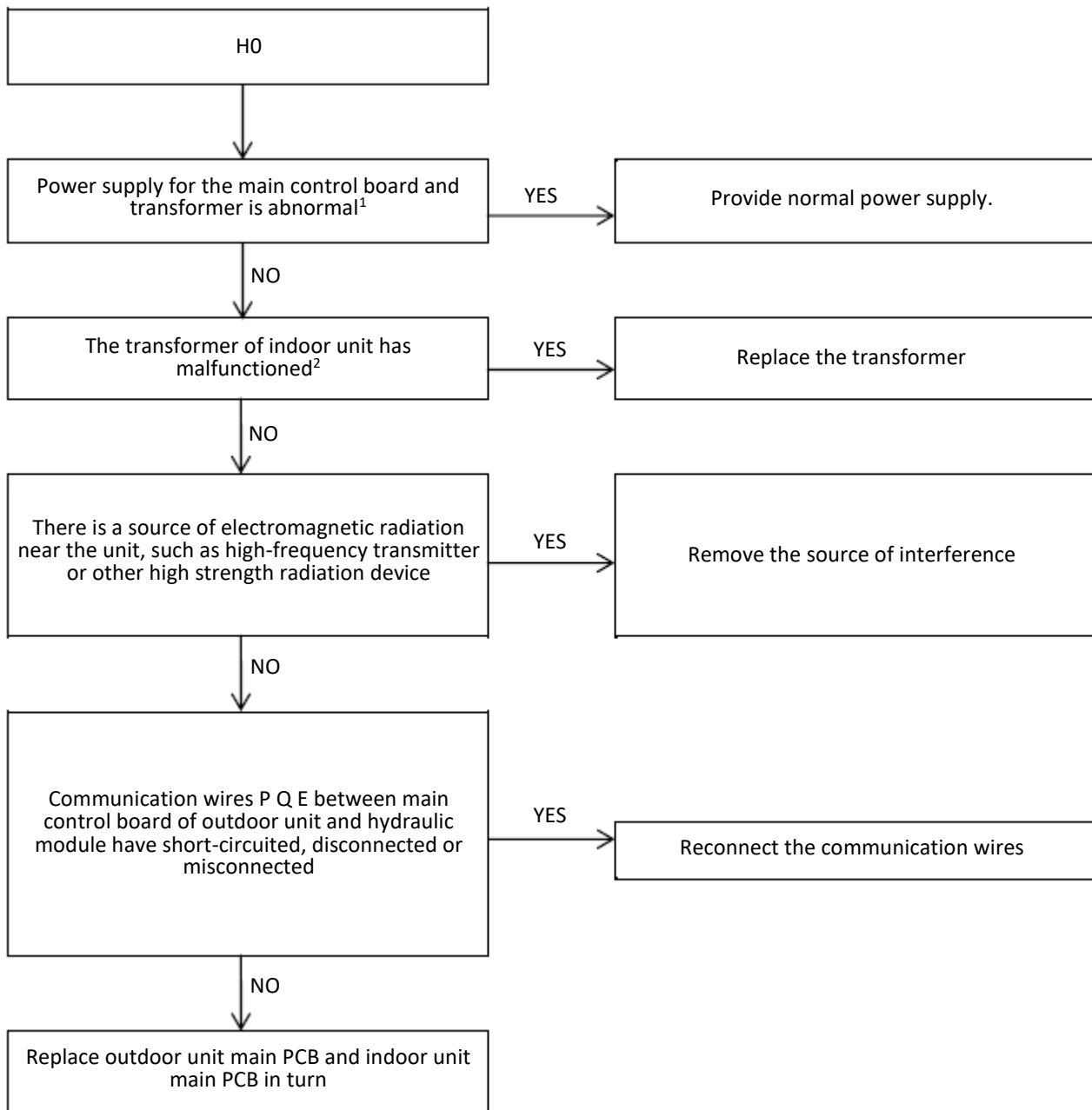

Notes:

1. Measure the voltages of transformer input port and output port. The input voltage of transformer is 220V AC, the output voltage is 13.5V AC. If any voltages are abnormal, the power supply for the main control board of hydraulic module and transformer will be abnormal.
2. Measure the voltages of transformer output ports. If the voltages are not normal, the transformer has malfunctioned.

4.11 H1 Troubleshooting

4.11.1 Digital display output



4.11.2 Description

- Communication error between outdoor unit main control board and inverter module.
- The unit stops running.
- Error code is displayed on outdoor unit main PCB and user interface.

4.11.3 Possible causes

- Abnormal power supply.
- Interference from a source of electromagnetic radiation.
- Outdoor unit main PCB or inverter driven module damaged.

4.11.4 Procedure

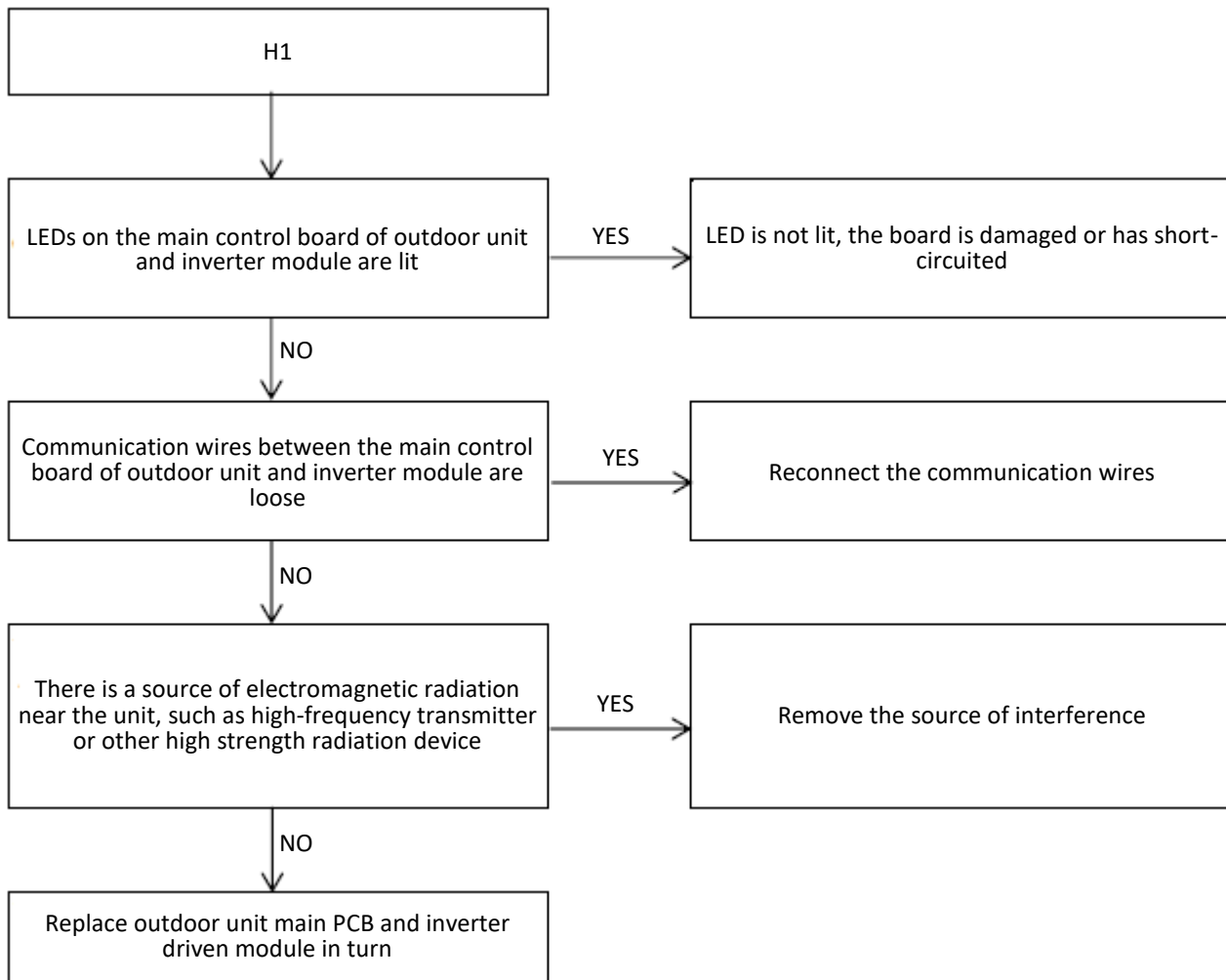

4.12 H6, HH Troubleshooting

4.12.1 Digital display output

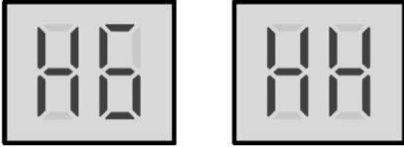

4.12.2 Description

- H6 indicates a DC fan error.
- HH indicates that H6 protection has occurred 10 times in 2 hours. When HH error occurs, a manual system restart is required before the system can resume operation. The cause of HH error should be addressed promptly in order to avoid system damage.
- The unit stops running.
- Error code is displayed on outdoor unit main PCB and user interface.

4.12.3 Possible causes

- DC fan wire is loose.
- High wind speed.
- Motor blocked or has failed.
- Inverter module is damaged.
- Main PCB is damaged.

4.12.4 Procedure

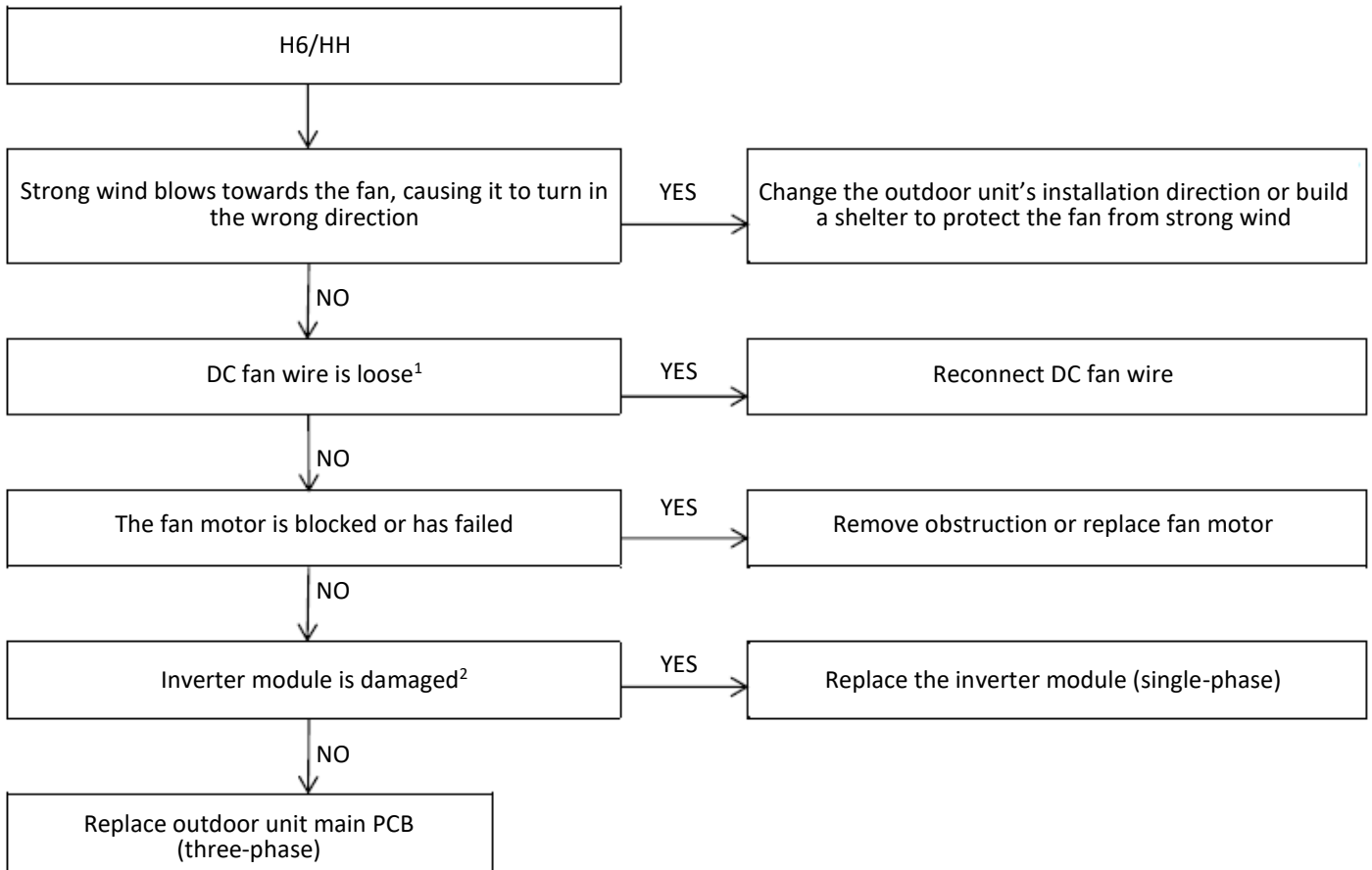

Notes:

1. Refer to Figures 4-1.1 to 4-1.4 in Part 4, 1.1 "Outdoor Unit Electric Control Box Layout" and to the wiring diagrams.
2. Measure the voltage between the DC fan motor power supply's white and black wires. The normal voltage is 15V when the unit is in standby. If the voltage is significantly different from 15V, the IPM module on the inverter module is damaged. DC fan connection to port CN19 on the outdoor unit inverter module PCB single-phase MiSAN-YEE 1 S 2.1-5.1 (labelled 5 in Figure 4-2.5 in Part 4, 2.3 "Main PCBs for Refrigerant System, Inverter Module"), port CN19 on the outdoor unit inverter module PCB single-phase MiSAN-YEE 1 S 6.1-8.1 (labelled 4 in Figure 4-2.6 in Part 4, 2.3 "Main PCBs for Refrigerant System, Inverter Module"), port CN109 on the outdoor unit inverter module PCB three-phase MiSAN-YEE 1 S 6.1-8.1 (labelled 30 in Figure 4-2.4 in Part 4, 2.3 "Main PCBs for Refrigerant System, Inverter Module").

4.13 H7 Troubleshooting

4.13.1 Digital display output



4.13.2 Description

- Abnormal main circuit voltage.
- The unit stops running.
- Error code is displayed on outdoor unit main PCB and user interface.

4.13.3 Possible causes

- Power supply voltage not within 90%~110% of rated voltage.
- Outdoor unit main PCB is damaged.

4.13.4 Procedure

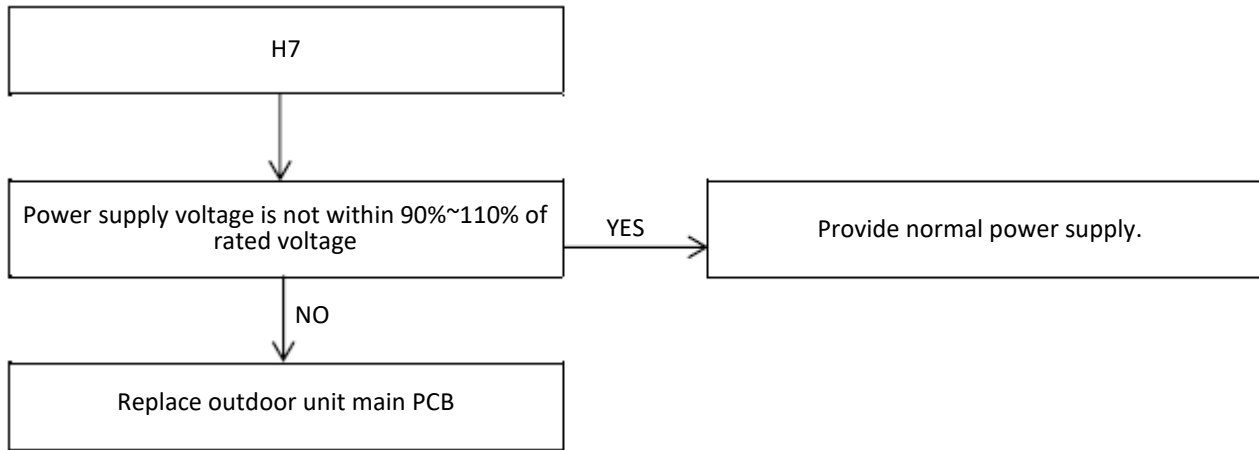

4.14 H8 Troubleshooting

4.14.1 Digital display output



4.14.2 Description

- High pressure sensor error
- SPHERA EVO stops running.
- Error code is displayed on outdoor unit main PCB and user interface.

4.14.3 Possible causes

- Temperature sensor not connected properly or has malfunctioned.
- Outdoor unit main PCB is damaged.

4.14.4 Procedure

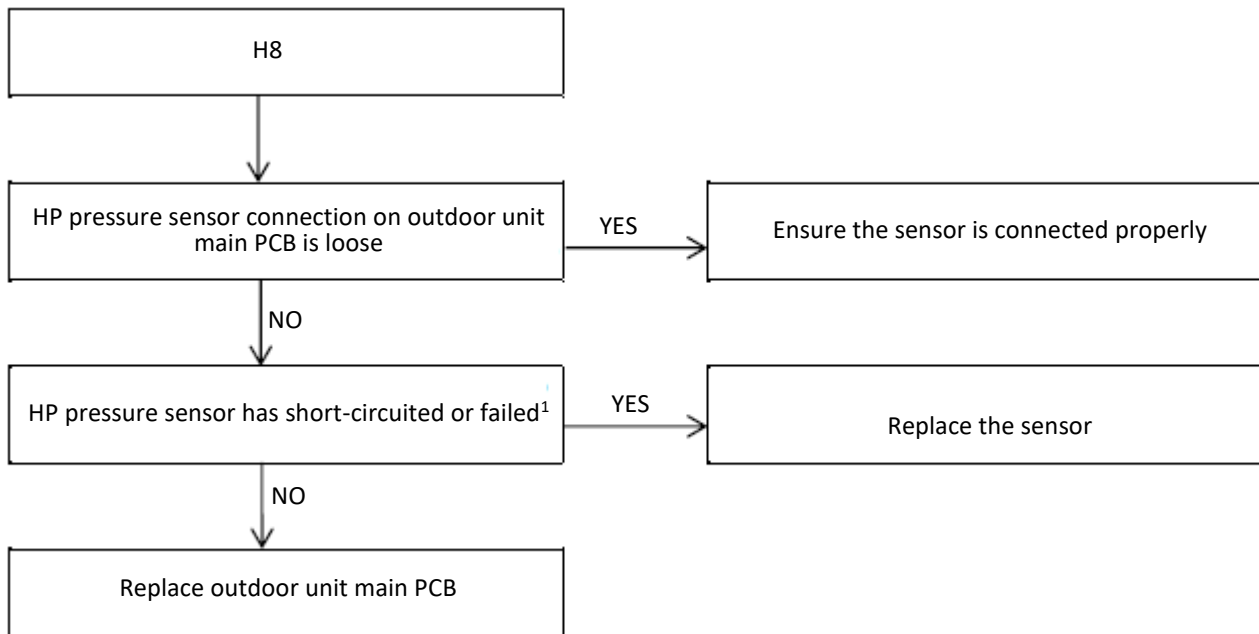

Notes:

1. Measure the resistance among the three terminals of the pressure sensor. If the resistance is of the order of mega Ohms or infinite, the pressure sensor has failed. Pressure sensor connection is port CN4 on the outdoor unit refrigerant system main PCB single-phase MiSAN-YEE 1 S 2.1- 5.1 (labelled 19 in Figure 4-2.2 Part 4, 2.3 "Main PCB for Refrigerant System, Inverter Module"), port CN4 on the outdoor unit refrigerant system main PCB single-phase MiSAN-YEE 1 S 6.1-8.1 (labelled 19 in Figure 4-2.3 Part 4, 2.3 "Main PCB for Refrigerant System, Inverter Module"), port CN6 on the outdoor unit refrigerant system main PCB three-phase MiSAN-YEE 1 S 6.1-8.1 (labelled 13 in Figure 4-2.4 Part 4, 2.3 "Main PCB for Refrigerant System, Inverter Module").

4.15 P0, HP Troubleshooting

4.15.1 Digital display output

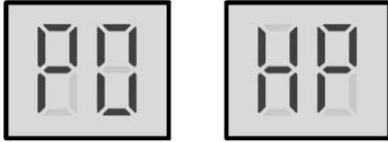

4.15.2 Description

- P0 indicates suction pipe low pressure protection. When the suction pressure falls below 0.14MPa, the system displays P0 protection and the unit stops running. When the pressure rises above 0.3MPa, P0 is removed and normal operation resumes.
- HP indicates P0 protection has occurred 3 times in 60 minutes. When an HP error occurs, a manual system restart is required before the system can resume operation.
- Error code is displayed on outdoor unit main PCB and user interface.

4.15.3 Possible causes

- Low pressure switch not connected properly or has malfunctioned.
- Insufficient refrigerant.
- Low pressure side blockage.
- Poor evaporator heat exchange in heating mode or DHW mode.
- Insufficient water flow in cooling mode.
- Outdoor unit main PCB damaged.

4.15.4 Procedure

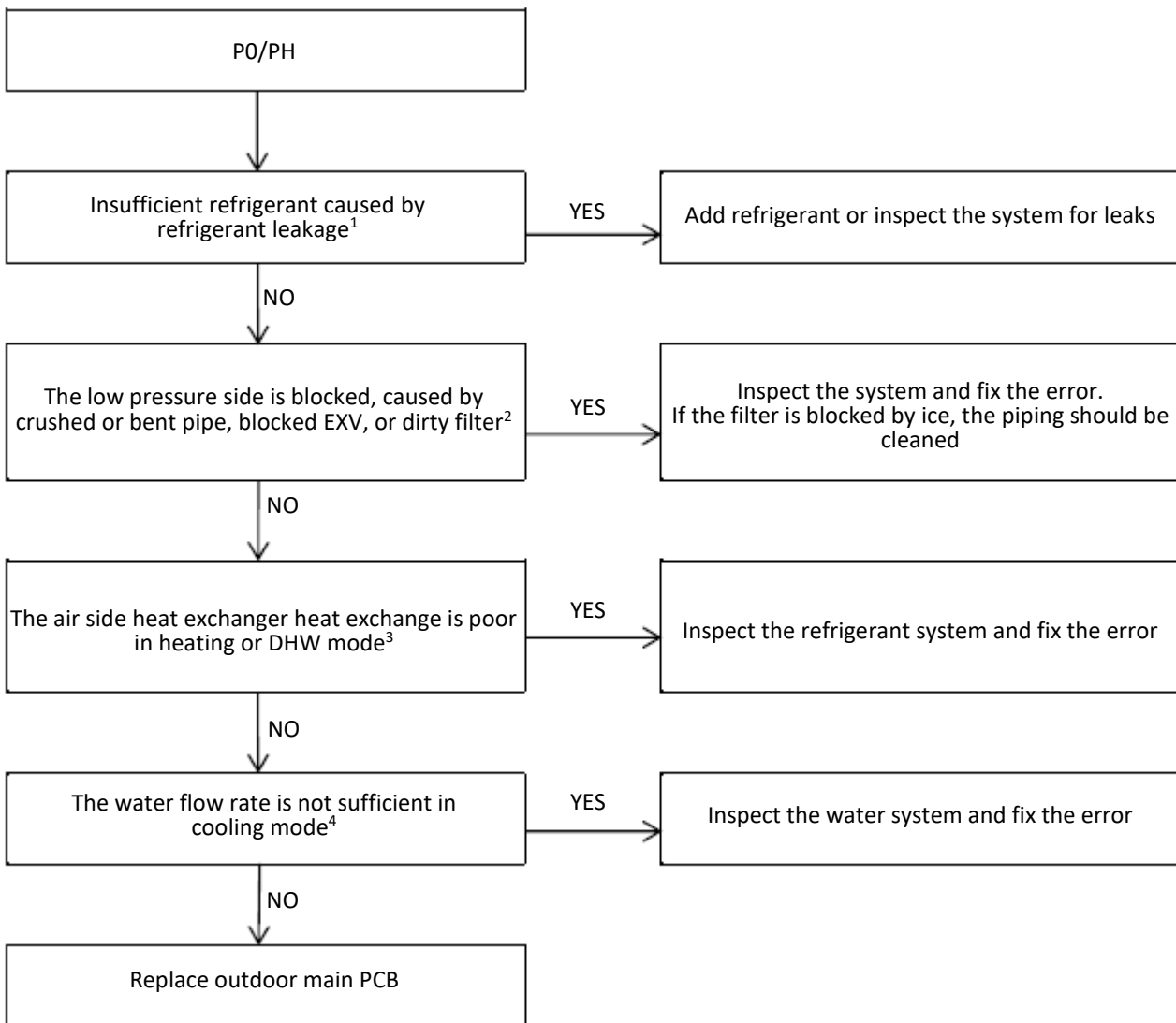

Notes:

1. To check for insufficient refrigerant:
 - An insufficiency of refrigerant causes compressor discharge temperature to be higher than normal, discharge and suction pressures to be lower than normal and compressor current to be lower than normal, and may cause frosting to occur on the suction pipe. These issues disappear once sufficient refrigerant has been charged into the system.
2. A low pressure side blockage causes compressor discharge temperature to be higher than normal, suction pressure to be lower than normal and compressor current to be lower than normal, and may cause frosting to occur on the suction pipe. For normal system parameters.
3. Check air side heat exchanger, fan and air outlets for dirt/blockages.
4. Check water side heat exchanger, water piping, circulator pumps and water flow switch for dirt/blockages.

4.16 P1 Troubleshooting

4.16.1 Digital display output



4.16.2 Description

- Discharge pipe high pressure protection. When the discharge pressure rises above 4.3 MPa, the system displays P1 protection and the unit stops running. When the discharge pressure falls below 3.6 MPa, P1 is removed and normal operation resumes.
- Error code is displayed on outdoor unit main PCB and user interface.

4.16.3 Possible causes

- Pressure sensor/switch not connected properly or has malfunctioned.
- Excess refrigerant.
- System contains air or nitrogen.
- High pressure side blockage.
- Poor condenser heat exchange.
- Outdoor unit main PCB damaged.

4.16.4 Procedure

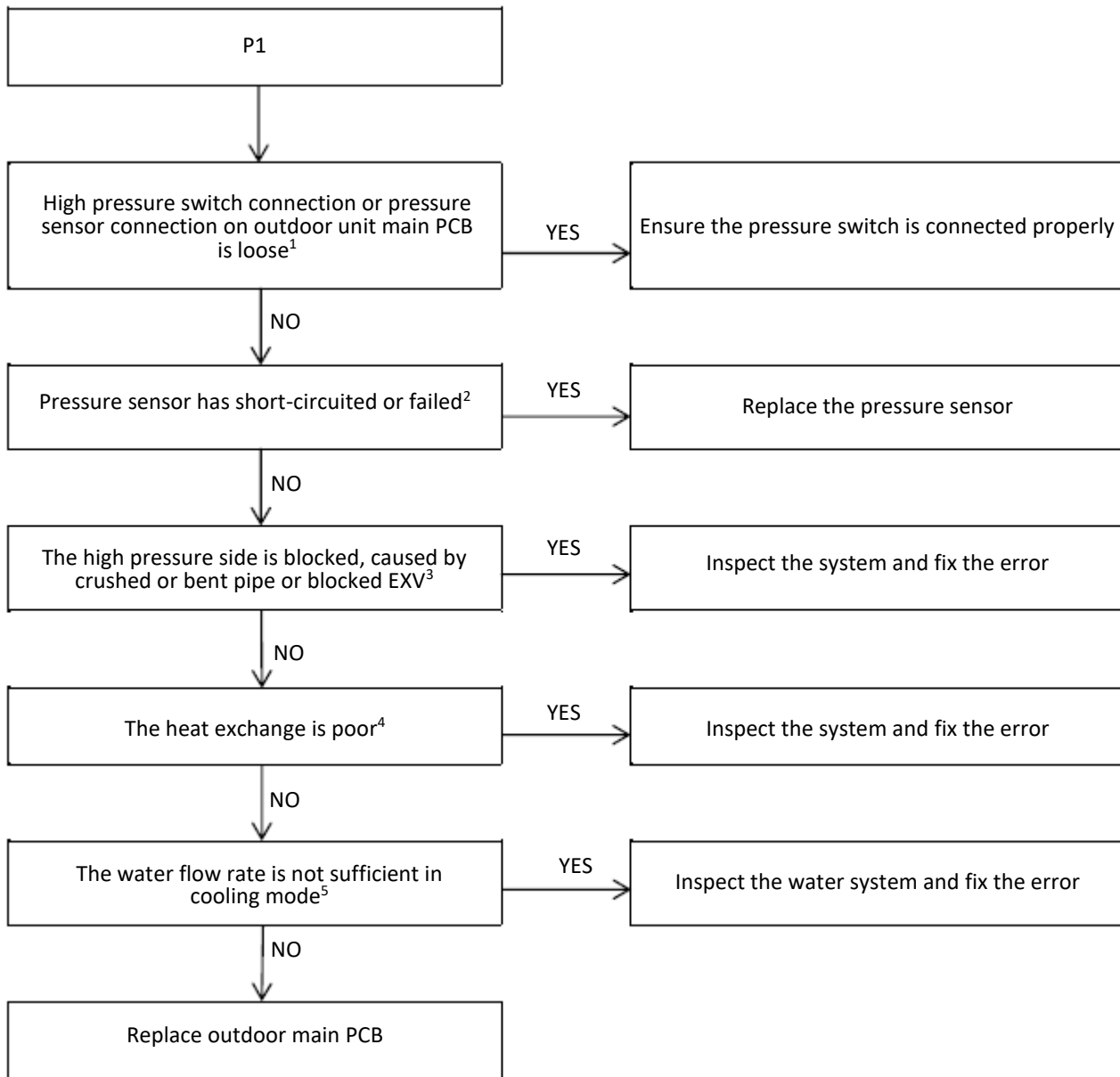

Notes:

1. High pressure switch connection is port CN13 on the outdoor unit main PCB single-phase MiSAN-YEE 1 S 2.1-5.1 (labelled 16 in Figure 4-2.2 in Part 4, 2.3 "Main PCBs for Refrigerant System, Inverter Module", port CN13 on the outdoor unit main PCB single-phase MiSAN-YEE 1 S 6.1-8.1 (labelled 16 in Figure 4-2.2 in Part 4, 2.3 "Main PCBs for Refrigerant System, Inverter Module", port CN31 on the outdoor unit main PCB three-phase MiSAN-YEE 1 S 6.1-8.1 (labelled 20 in Figure 4-2.4 in Part 4, 2.3 "Main PCBs for Refrigerant System, Inverter Module").
2. Measure the resistance among the three terminals of the pressure sensor. If the resistance is of the order of mega Ohms or infinite, the pressure sensor has failed.
3. High pressure side blockage causes discharge temperature to be higher than normal, discharge pressure to be higher than normal and suction pressure to be lower than normal.
4. In heating mode check water side heat exchanger, water piping, circulator pumps and water flow switch for dirt/blockages. In cooling mode check air side heat exchanger, fans and air outlets for dirt/blockages.
5. Check water pressure on the pressure gauge. If the water pressure is not > 1 bar, water flow is insufficient. Refer to Figure 2-1.6 in Part 2, 1.2 "Indoor unit Layout".

4.17 P3 Troubleshooting

4.17.1 Digital display output



4.17.2 Description

- Compressor current protection.
- When the compressor current rises above the protection value (4/6kW models 18A, 8/10kW model 19A, 12/14/16kW 1ph model 30°, 12/14/16kW 3ph model 14A), the system displays P3 and the unit stops running. When the current returns to the normal range, P3 is removed and normal operation resumes.
- Error code is displayed on outdoor unit main PCB and user interface.

4.17.3 Possible causes

- Poor condenser heat exchange.
- High pressure side blockage.
- Inverter module is damaged.
- Compressor damaged.
- Outdoor unit main PCB damaged.

4.17.4 Procedure

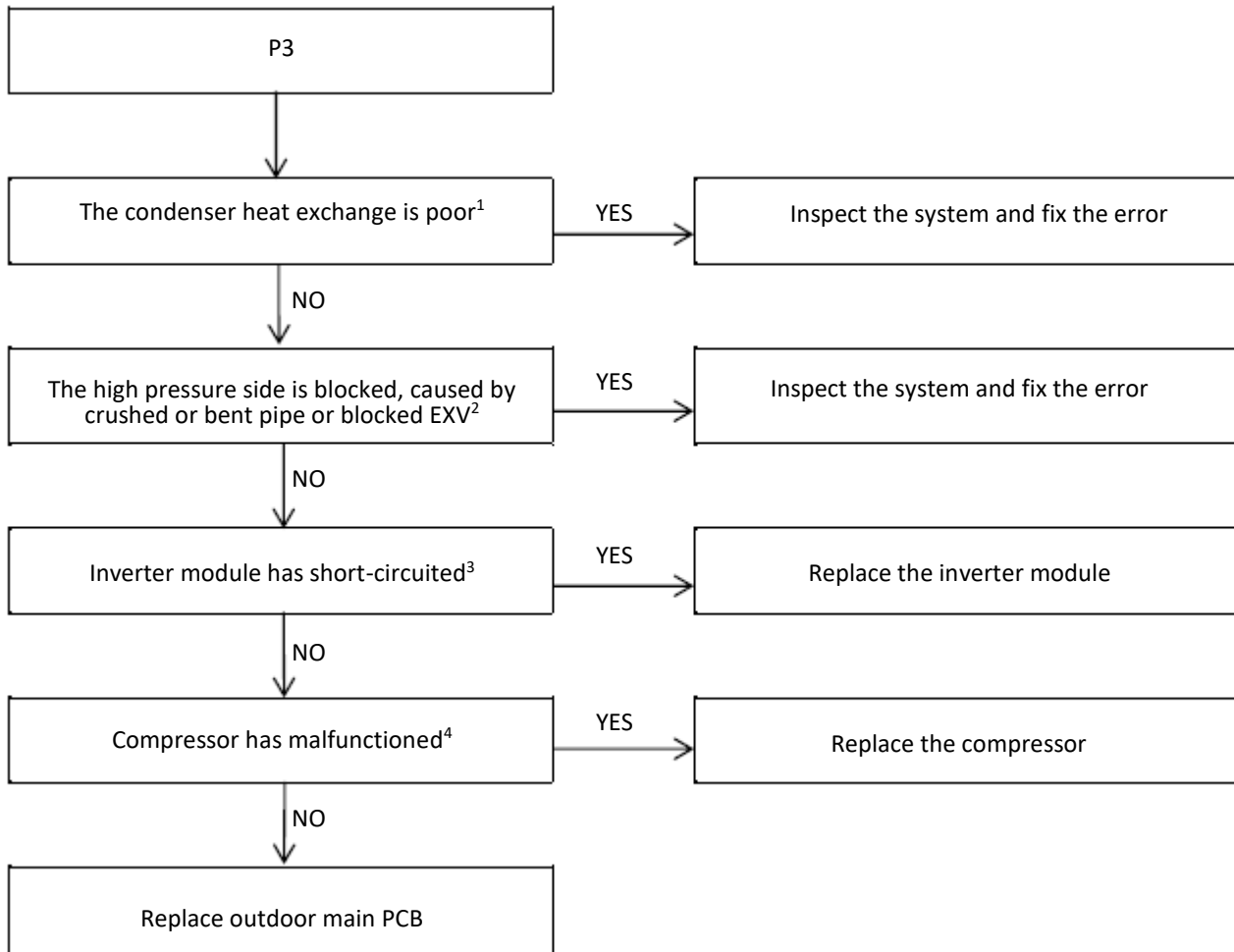

Notes:

1. In heating mode check water side heat exchanger, water piping, circulator pumps and water flow switch for dirt/blockages. In cooling mode check air side heat exchanger, air outlets and fans for dirt/blockages.
2. High pressure side blockage causes discharge temperature to be higher than normal, discharge pressure to be higher than normal and suction pressure to be lower than normal.
3. Set a multi-meter to buzzer mode and test any two terminals of P N and U V W of the inverter module. If the buzzer sounds, the inverter module has short-circuited.
4. The normal resistances of the inverter compressor are 0.7-1.5Ω among U V W and infinite between each of U V W and ground. If any of the resistances differ from these specifications, the compressor has malfunctioned.

4.18 P4 Troubleshooting

4.18.1 Digital display output



4.18.2 Description

- Discharge temperature protection
- When the compressor discharge temperature rises above 115°C, the system displays P4 protection and SPHERA EVO stops running. When the discharge temperature falls below 90°C, P4 is removed and normal operation resumes.
- Error code is displayed on outdoor unit main PCB and user interface.

4.18.3 Possible causes

- Temperature sensor error
- High pressure side blockage.
- Poor condenser heat exchange.
- Outdoor unit main PCB damaged.

4.18.4 Procedure

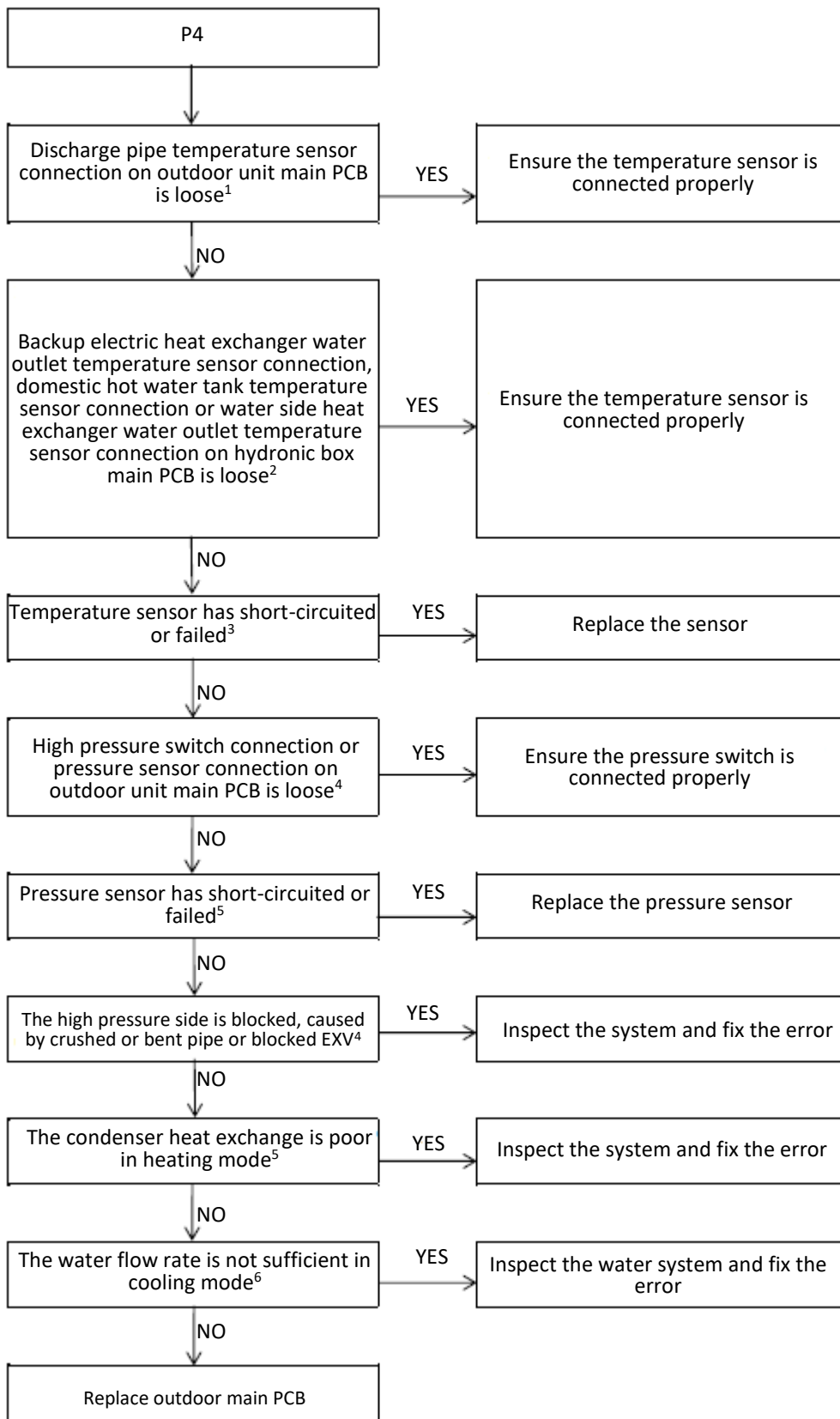

Notes:

1. Discharge pipe temperature sensor connection is port CN8 on the outdoor unit refrigerant system main PCB single-phase MiSAN-YEE 1 S 2.1-5.1 (labelled 15 in Figure 4-2.2 in Part 4, 2.3 "Main PCBs for Refrigerant System, Inverter Module"), port CN8 on the outdoor unit refrigerant system main PCB single-phase MiSAN-YEE 1 S 5.1-6.1 (labelled 15 in Figure 4-2.3 in Part 4, 2.3 "Main PCBs for Refrigerant System, Inverter Module"), port CN4 on the outdoor unit refrigerant system main PCB three-phase MiSAN-YEE 1 S 6.1-8.1 (labelled 15 in Figure 4-2.4 in Part 4, 2.3 "Main PCBs for Refrigerant System, Inverter Module").
2. Backup electric heat exchanger water outlet temperature sensor and heat exchanger water outlet temperature sensor connections are port CN6 on the hydronic box main PCB (labelled 10 in Figure 4-2.1 in Part 4, 2.2 "Main PCB for Hydronic System"). Domestic hot water tank temperature sensor connection is port CN13 on hydronic box main PCB (labelled 13 in Figure 4-2.1 in Part 4, 2.2 "Main PCB for Hydronic System").
3. Measure sensor resistance. If the resistance is too low, the sensor has short-circuited. If the resistance is not consistent with the sensor's resistance characteristics table, the sensor has failed. Refer to Part 2, 1 "Layout of Functional Components" and to Table 5-5.1 or 5-5.2 in Part 5, 5.1 "Temperature Sensor Resistance Characteristics".
4. High pressure switch connection is port CN13 on the outdoor unit refrigerant system main PCB single-phase MiSAN-YEE 1 S 2.1-5.1 (labelled 16 in Figure 4-2.2 in Part 4, 2.3 "Main PCBs for Refrigerant System, Inverter Module"), port CN13 on the outdoor unit refrigerant system main PCB single-phase MiSAN-YEE 1 S 5.1-6.1 (labelled 16 in Figure 4-2.3 in Part 4, 2.3 "Main PCBs for Refrigerant System, Inverter Module"), port CN31 on the outdoor unit refrigerant system main PCB three-phase MiSAN-YEE 1 S 6.1-8.1 (labelled 20 in Figure 4-2.4 in Part 4, 2.3 "Main PCBs for Refrigerant System, Inverter Module").
5. Measure the resistance among the three terminals of the pressure sensor. If the resistance is of the order of mega Ohms or infinite, the pressure sensor has failed.
6. High pressure side blockage causes discharge temperature to be higher than normal, discharge pressure to be higher than normal and suction pressure to be lower than normal.
7. Check air side heat exchanger, fan and air outlets for dirt/blockages.
8. Check the water side heat exchanger, water piping, circulator pumps and water flow switch for dirt/blockages.

4.19 P5 Troubleshooting

4.19.1 Digital display output



4.19.2 Description

- High temperature difference between water side heater exchanger water inlet and water outlet temperatures protection.
- The unit stops running.
- Error code is displayed on outdoor unit main PCB and user interface.

4.19.3 Possible causes

- Temperature sensor not connected properly or has malfunctioned.
- Water piping contains air.
- Insufficient water flow.
- Indoor unit main PCB damaged.

4.19.4 Procedure

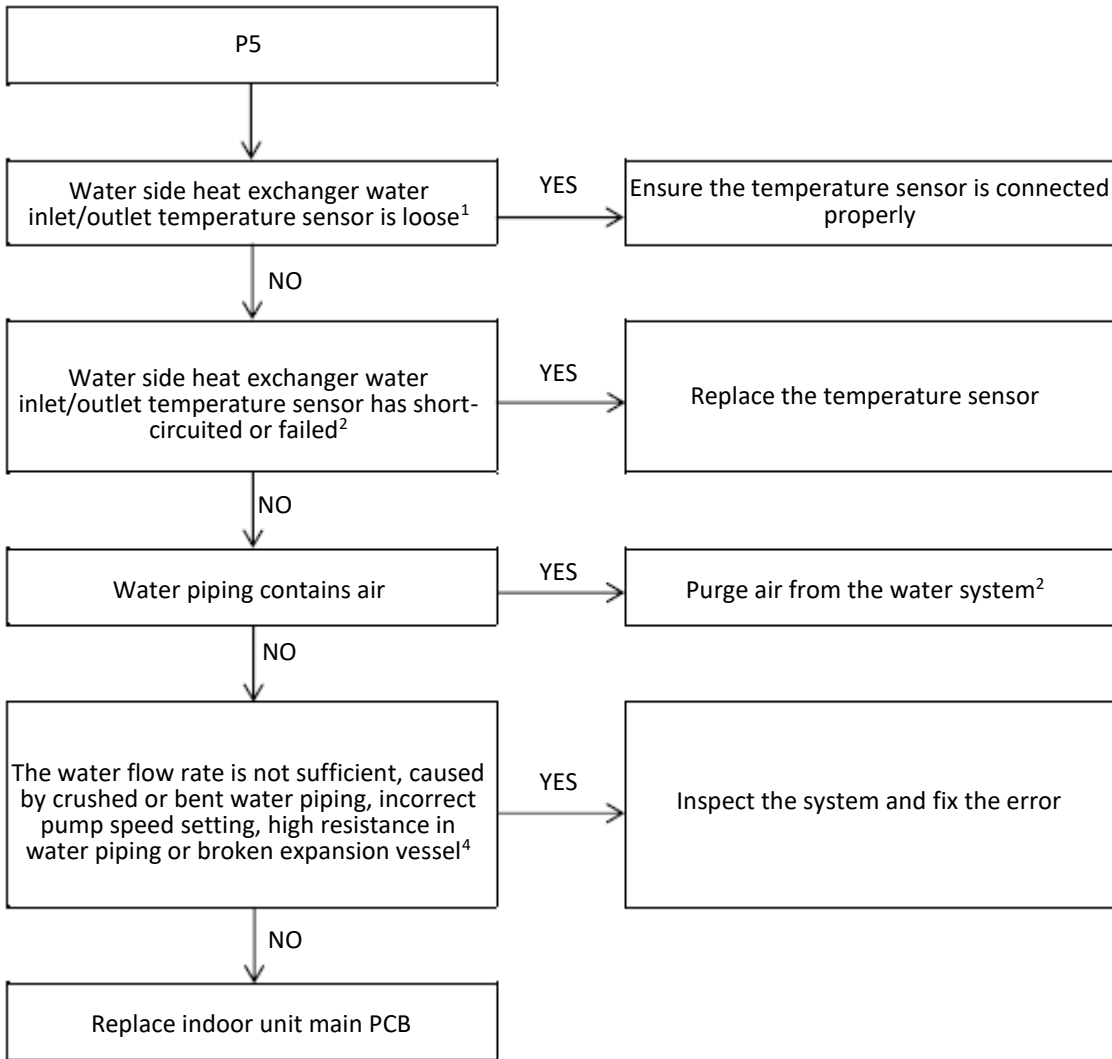

Notes:

1. Water side heat exchanger water inlet temperature sensor and water side heat exchanger water outlet temperature sensor connections are port CN6 on the indoor unit main PCB (labelled 10 in Figure 4-2.1 in Part 4, 2.2 "Main PCB for Hydronic System").
2. Measure sensor resistance. If the resistance is too low, the sensor has short-circuited. If the resistance is not consistent with the sensor's resistance characteristics table, the sensor has failed. Refer to Part 2, 1.2 "Indoor unit Layout" and to Table 5-5.3 in Part 5, 5.1 "Temperature Sensor Resistance Characteristics".
3. Check water pressure on the pressure gauge. If the water pressure is not > 1 bar, water flow is insufficient. Refer to Figures 2-1.7 and 2-1.8 in Part 2, 1.2 "Indoor unit Layout".

4.20 P6 Troubleshooting for single-phase models

4.20.1 Digital display output

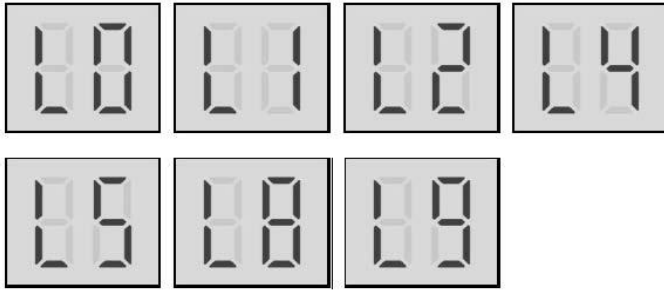

4.20.2 Description

- Inverter module protection
- The unit stops running.
- Specific error code L0, L1, L2, L4, L5, L7, L8 or L9 is displayed on outdoor unit main PCB and user interface.

4.20.3 Possible causes

- Inverter module protection
- DC bus low or high voltage protection.
- MCE error (Bus low or high voltage protection or overcurrent protection **)
- Zero speed protection.
- Phase sequence error.
- Excessive compressor frequency variation.
- High pressure protection
- PED board auto-control error

4.20.4 Specific error codes for inverter module protection

Table 4-4.1: Specific error codes

Specific error code	Description
L0	Inverter module protection
L1	DC bus low voltage protection
L2	DC bus high voltage protection
L4	MCE error (**)
L5	Zero speed protection
L8	Compressor frequency variation greater than 15Hz within one second protection
L9	Actual compressor frequency differs from target frequency by more than 15Hz protection

The specific error codes can also be obtained from the LED indicators on the inverter module.

Table 4-4.2: Errors indicated on LED, MiSAN-YEE 1 S 2.1-5.1 single-phase

LED301 flashing pattern (green) LED302 always on (red)	Corresponding error
Flashes 8 times and stops for 1 second, then repeats.	L0 - Inverter module protection
Flashes 9 times and stops for 1 second, then repeats.	L1 - DC bus low voltage protection
Flashes 10 times and stops for 1 second, then repeats.	L2 - DC bus high voltage protection
Flashes 12 times and stops for 1 second, then repeats.	L4 - MCE error
Flashes 13 times and stops for 1 second, then repeats.	L5 - Zero speed protection
Flashes 15 times and stops for 1 second, then repeats.	L7 - Phase sequence error
Flashes 16 times and stops for 1 second, then repeats.	L8 Compressor frequency variation greater than 15Hz within one second protection
Flashes 17 times and stops for 1 second, then repeats.	L9 - Actual compressor frequency differs from target frequency by more than 15Hz protection

Table 4-4.3: Errors indicated on LEDs, MiSAN-YEE 1 S 6.1-8.1 single-phase

LED1 flashing pattern (green) LED2 always on (red)	Corresponding error
Flashes 3 times and stops for 1 second, then repeats.	P1 - High pressure protection
Flashes 5 times and stops for 1 second, then repeats.	bH - PED board check failed
Flashes 8 times and stops for 1 second, then repeats.	L0 - Inverter module protection
Flashes 9 times and stops for 1 second, then repeats.	L1 - DC bus low voltage protection
Flashes 10 times and stops for 1 second, then repeats.	L2 - DC bus high voltage protection
Flashes 12 times and stops for 1 second, then repeats.	L4 - MCE error
Flashes 13 times and stops for 1 second, then repeats.	L5 - Zero speed protection
Flashes 16 times and stops for 1 second, then repeats.	L8 Compressor frequency variation greater than 15Hz within one second protection
Flashes 17 times and stops for 1 second, then repeats.	L9 - Actual compressor frequency differs from target frequency by more than 15Hz protection

Table 4-4.1: Position of LEDs on inverter module

Inverter module (MiSAN-YEE 1 S 2.1-5.1) LED301/302/303



Inverter module (MiSAN-YEE 1 S 6.1-8.1) LED1/ LED2/ LED3

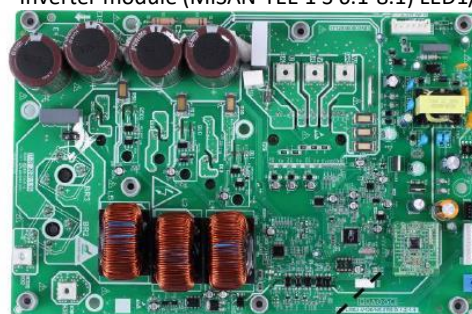

4.20.5 Principle of DC inverter

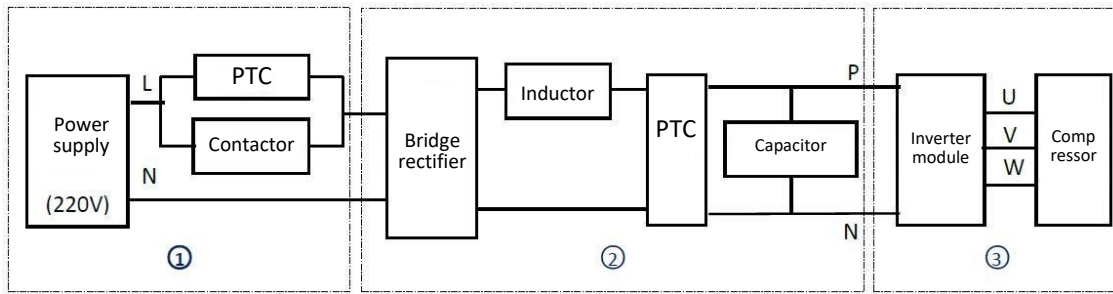

- ①. Contactor is open, the current across the PTC to charge capacitor, after 5 seconds the contactor closed.
- ② 220/240V AC power supply change to DC power supply after bridge rectifier.
- ③ The capacity output steady power supply for inverter module P N terminals. In standby the voltage between P and N terminal on inverter module is 1.4 times the AC supply. When the fan motor is running, the voltage between P and N terminal on inverter module is 377V DC.

4.20.6 L0/L4 Troubleshooting

Situation 1: L0 or L4 error appears immediately after the outdoor unit is switched-on

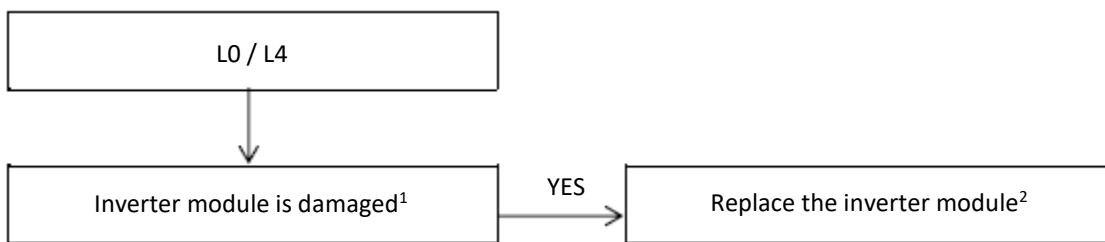

- Notes:
1. Measure the resistance between each of U, V and W and each of P and N on the inverter module. All the resistances should be infinite. If any of them are not infinite, the inverter module is damaged and should be replaced. Refer to Figure 4-2.3 or 4-2.5 in Part 4, 2.1 "Outdoor Unit PCBs".
 2. When replacing an inverter module, a layer of thermally conductive silica gel should be painted on the IPM module, IGBT, diode, bridge rectifier (on the reverse side of the inverter module). Refer to Figure 4-4.1.

Figure 4-4.1: Replacing an inverter module

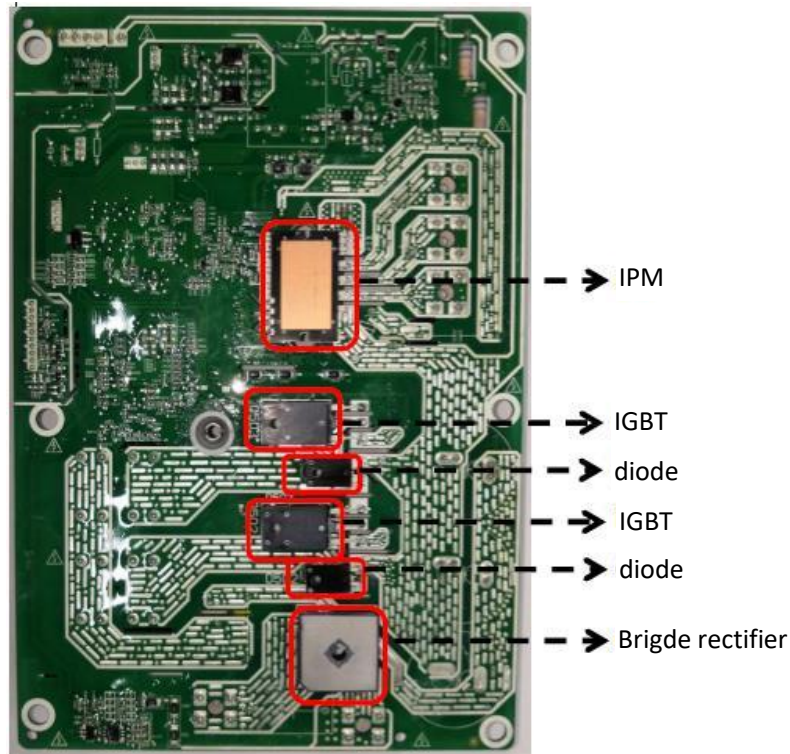

Situation 2: L0 or L4 error appears immediately after the compressor starts up

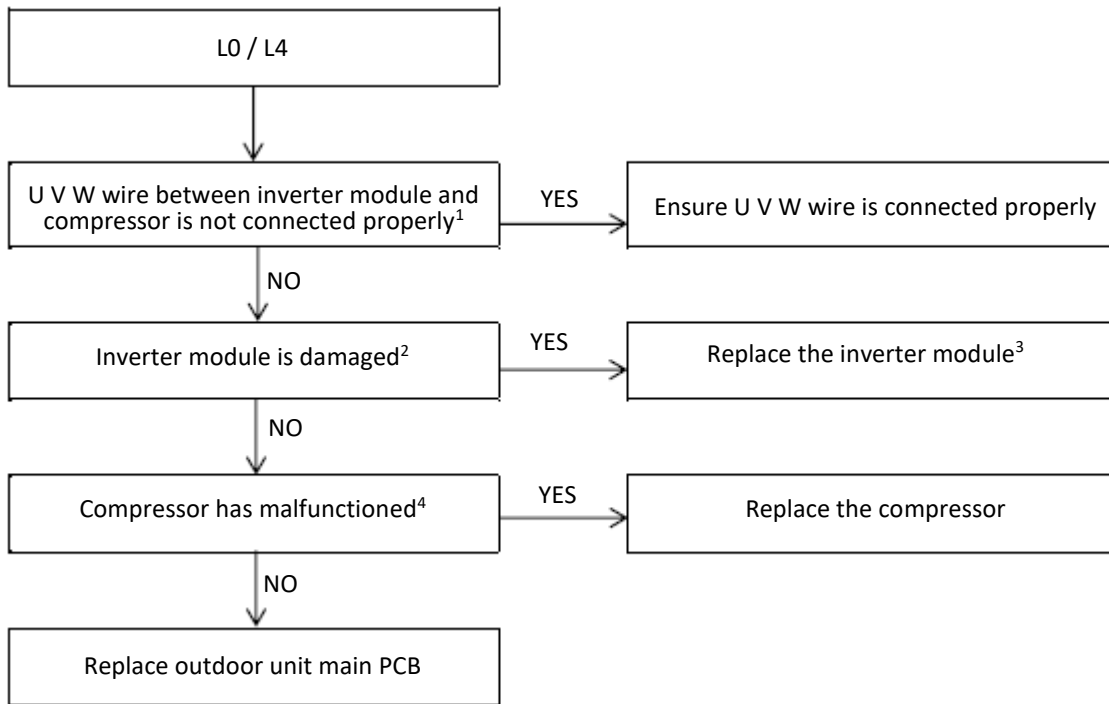

Notes:

1. Connect the U V W wire from the inverter module to the correct compressor terminals, as indicated by the labels on the compressor.
2. Measure the resistance between each of U, V and W and each of P and N on the inverter module. All the resistances should be infinite. If any of them are not infinite, the inverter module is damaged and should be replaced. Refer to Figure 4-2.85 or 4-2.7 in Part 4, 2.1 "Outdoor Unit PCBs".
3. When replacing an inverter module, a layer of thermally conductive silica gel should be painted on the IPM module, IGBT, diode, bridge rectifier (on the reverse side of the inverter module PCB). Refer to Figure 4-4.2.
4. The normal resistances of the inverter compressor are 0.7-1.5Ω among U V W and infinite between each of U V W and ground. If any of the resistances differ from these specifications, the compressor has malfunctioned.

Situation 3: L0 or L4 error appears after the compressor has been running for a period of time and the compressor speed is over 60 rps

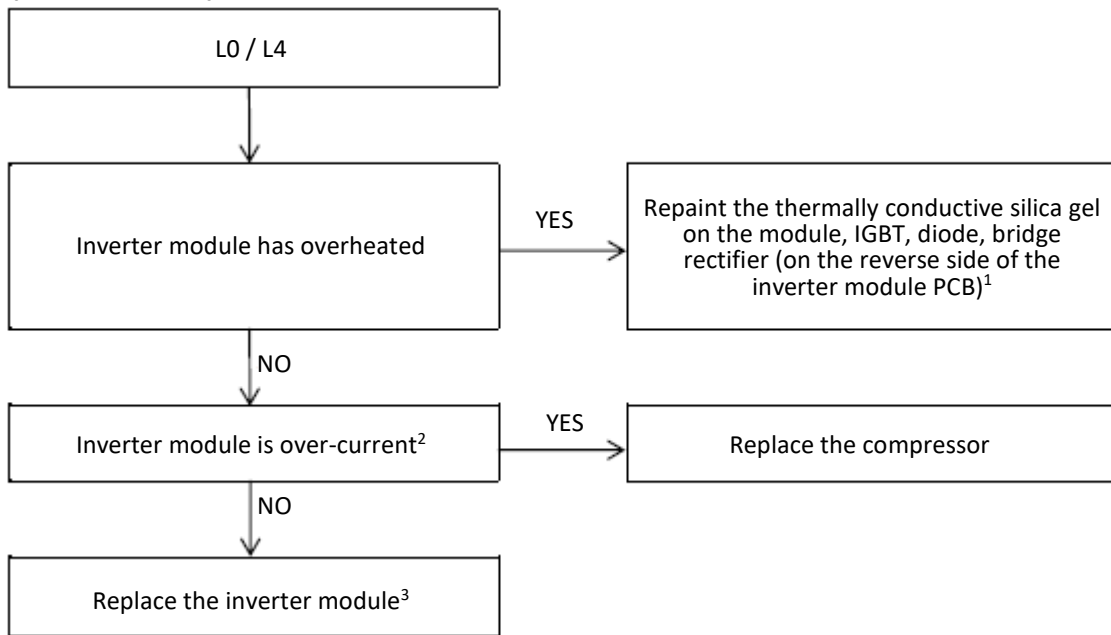

- Notes:
1. Refer to Figure 4-4.2.
 2. Use clip-on ammeter to measure the compressor current. If the current is normal it indicates that the inverter module has failed, if it is abnormal, it indicates that the compressor has failed.
 3. When replacing an inverter module, a layer of thermally conductive silica gel should be painted on the IPM module (on the reverse side of the inverter module PCB). Refer to Figure 4-4.2.

Situation 4: L0 error appears occasionally/irregularly

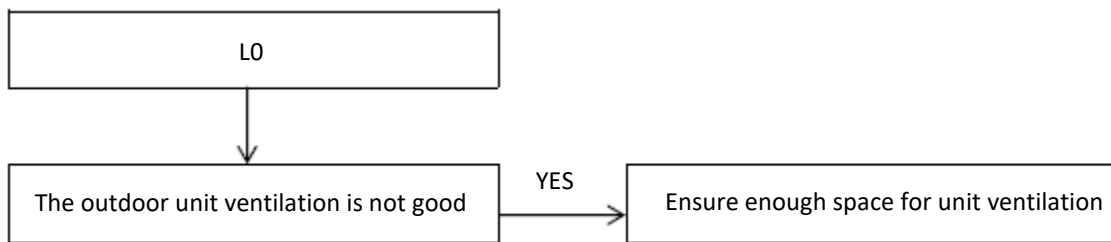

4.20.7 L1/L2 Troubleshooting

The normal DC voltage between terminals P and N on the inverter module is 1.4 times the AC power supply in standby and 377 V when the fan motor is running. If the voltage is lower than 160V, the unit displays an L1 error. If the voltage is higher than 500V, the unit displays an L2 error.

Figure 4-4.2: Inverter module terminals

Inverter module terminals (MiSAN-YEE 1 S2.1-5.1)

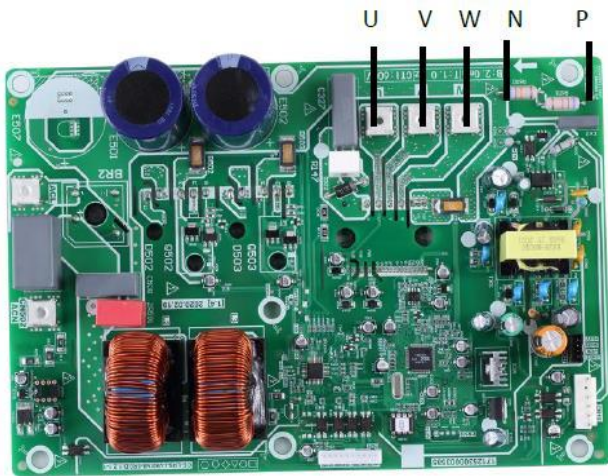

Inverter module terminals (MiSAN-YEE 1 S6.1-8.1)

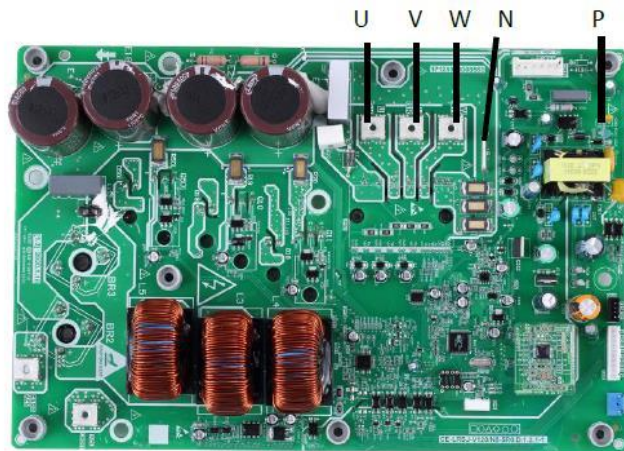

Situation 1: L1 or L2 error appears immediately after the outdoor unit is switched-on

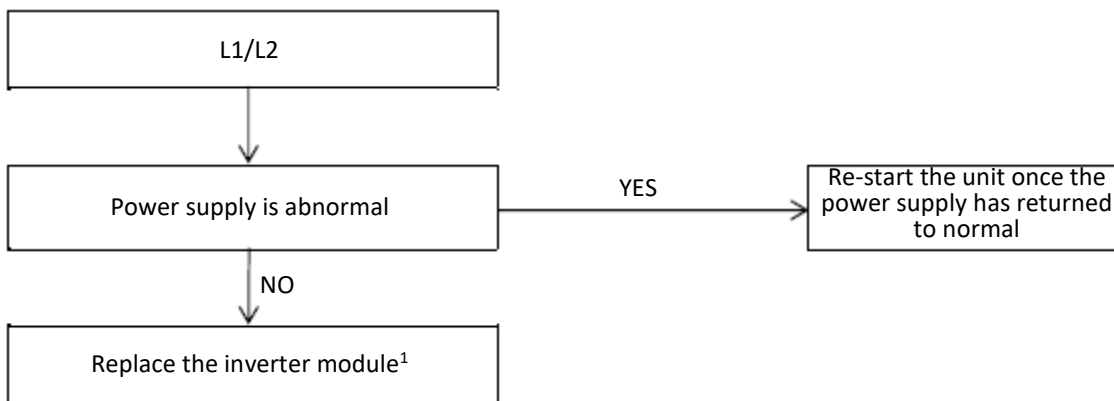

Notes:

1. When replacing an inverter module, a layer of thermally conductive silica gel should be painted on the IPM module, IGBT, diode, bridge rectifier (on the reverse side of the inverter module PCB). Refer to Figure 4-4.2.

Situation 2: L1 or L2 error appears after the compressor has been running for a period of time and the compressor speed is over 20 rps

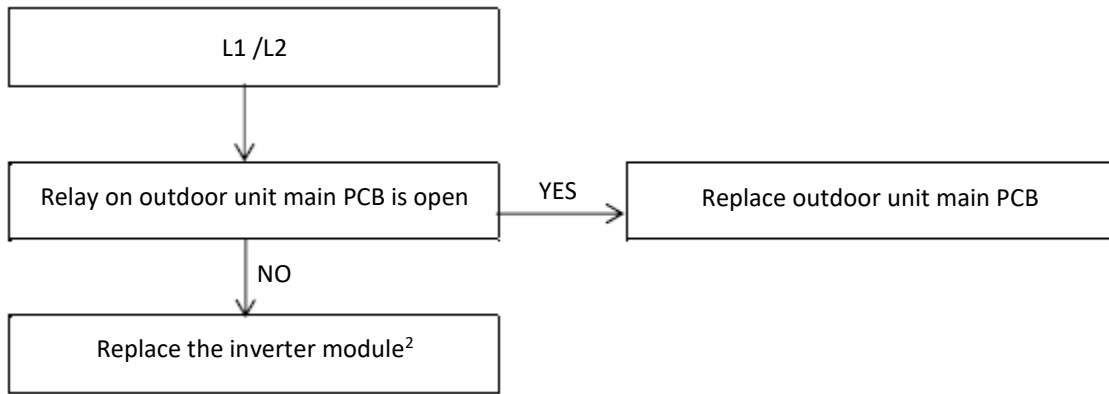

relay

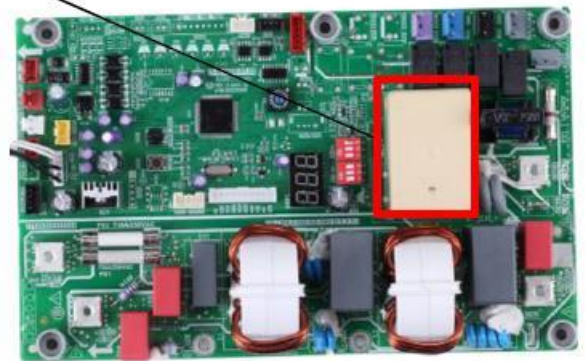
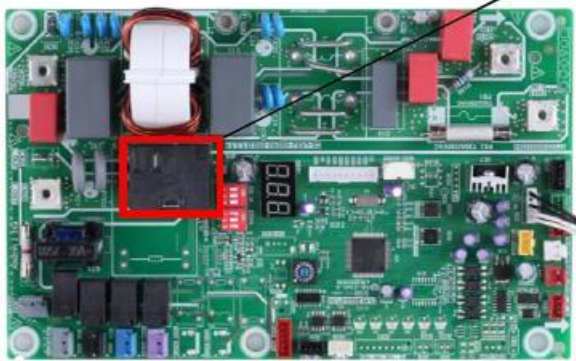

Notes:

1. If the fan motor is running and the DC voltage between terminals P and N on inverter module has decreased, relay on the main control board of outdoor unit is open.
2. When replacing an inverter module, a layer of thermally conductive silica gel should be painted on the PFC IPM module (on the reverse side of the inverter module PCB). Refer to Figure 4-4.2.

4.20.8 L5/L8/L9 Troubleshooting

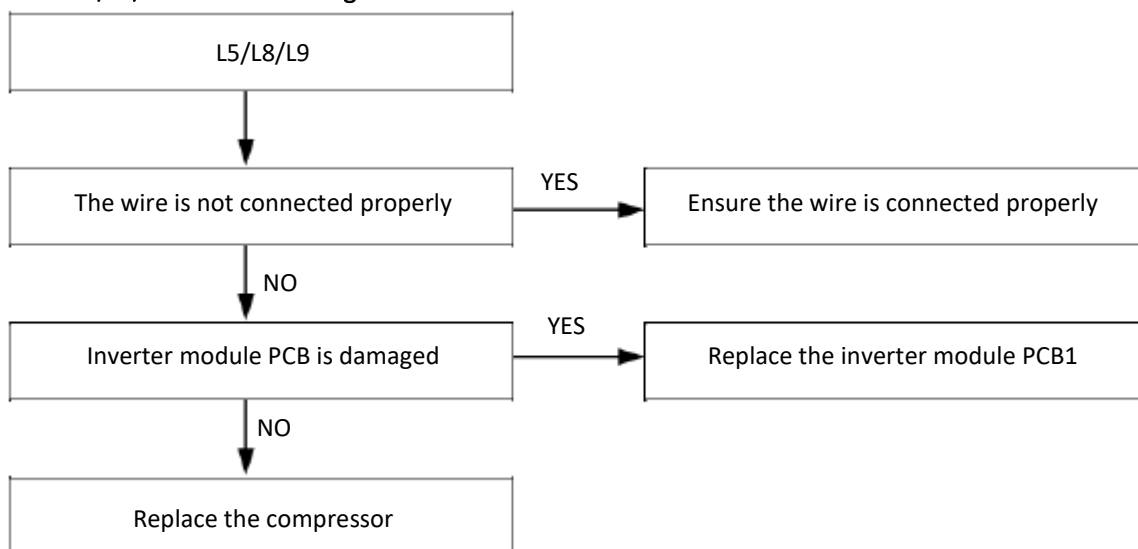

Notes:

1. When replacing an inverter module, a layer of thermally conductive silica gel should be painted on the IPM module (on the reverse side of the inverter module PCB). Refer to Figure 4-4.2.

4.21 P6 Troubleshooting for three-phase models

4.21.1 Digital display output

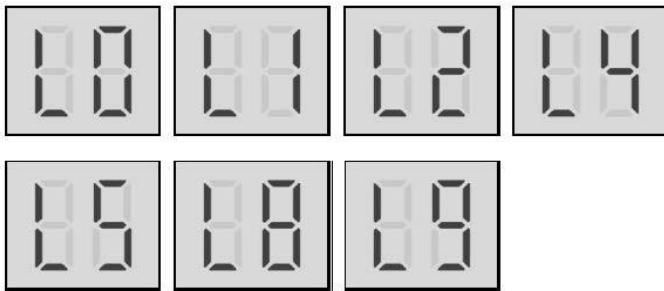

4.21.2 Description

- Inverter module protection
- The unit stops running.
- Specific error code L0, L1, L2, L4, L5, L7, L8 or L9 is displayed on outdoor unit main PCB and user interface.

4.21.3 Possible causes

- Inverter module protection
- DC bus low or high voltage protection.
- MCE error (Bus low or high voltage protection or overcurrent protection **)
- Zero speed protection.
- Phase sequence error.
- Excessive compressor frequency variation.
- High pressure protection
- Contactor blocked or auto-diagnostic error 908.

4.21.4 Specific error codes for inverter module protection

Table 4-4.4: Specific error codes

Specific error code	Description
L0	Inverter module protection
L1	DC bus low voltage protection
L2	DC bus high voltage protection
L4	MCE error (**)
L5	Zero speed protection
L8	Compressor frequency variation greater than 15Hz within one second protection
L9	Actual compressor frequency differs from target frequency by more than 15Hz protection

The specific error codes can also be obtained from the LED indicators LED1/LED2 on the inverter module.

Table 4-4.5: Errors indicated on LEDs, MiSAN-YEE 1 S 6.1-8.1 three-phase

LED1/LED2 flashing pattern	Corresponding error
Flashes 8 times and stops for 1 second, then repeats.	L0 - Inverter module protection
Flashes 9 times and stops for 1 second, then repeats.	L1 - DC bus low voltage protection
Flashes 10 times and stops for 1 second, then repeats.	L2 - DC bus high voltage protection
Flashes 12 times and stops for 1 second, then repeats.	L4 - MCE error
Flashes 13 times and stops for 1 second, then repeats.	L5 - Zero speed protection
Flashes 17 times and stops for 1 second, then repeats.	L8 Compressor frequency variation greater than 15Hz within one second protection L9 - Actual compressor frequency differs from target frequency by more than 15Hz protection
Flashes 3 times and stops for 1 second, then repeats.	bH - Contactor blocked or auto-diagnostic error 908.
Flashes 3 times and stops for 1 second, then repeats.	P1 - High pressure protection

Table 4-4.5: Position of LEDs on inverter module MiSAN-YEE 1 S 6.1-8.1 three-phase

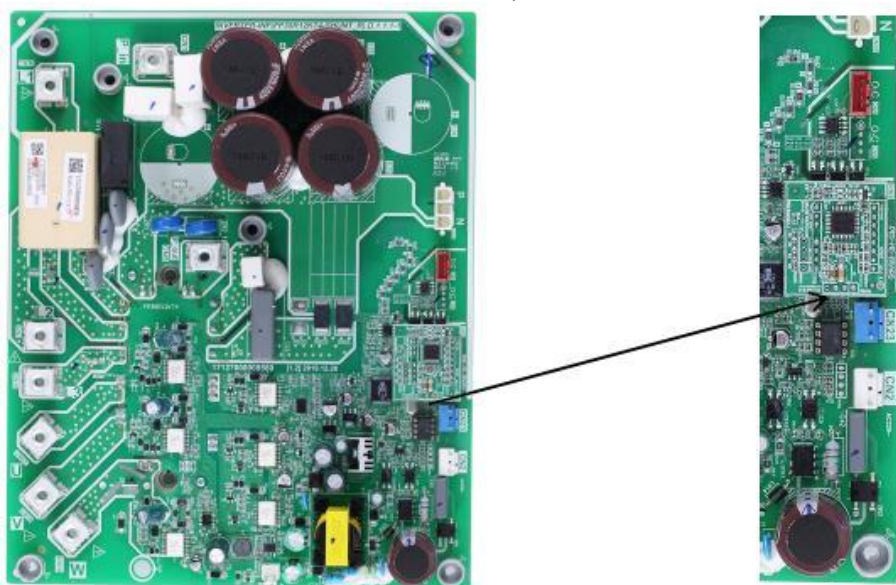

4.21.5 Principle of DC inverter

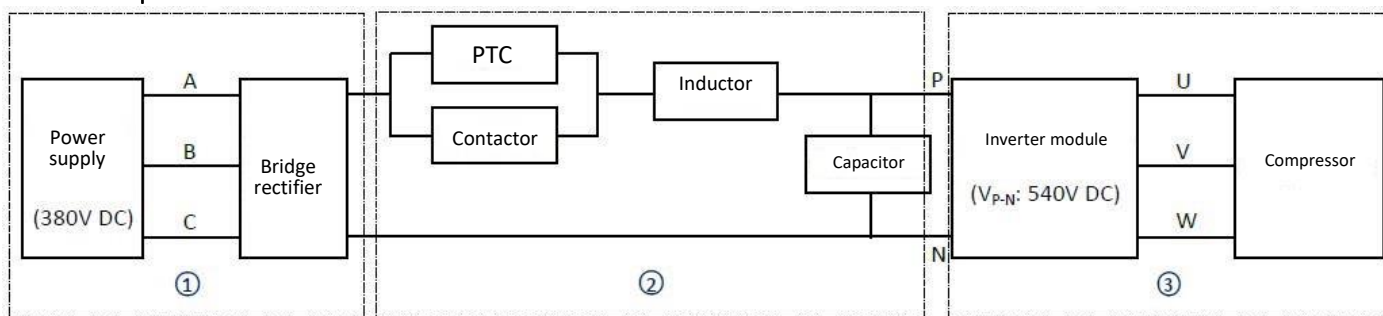

- ① 380-240V AC power supply change to DC power supply after bridge rectifier.
- ② Contactor is open, the current across the PTC to charge capacitor, after 5 seconds the contactor closed.
- ③ The capacity output steady 540V DC power supply for inverter module P N terminals.

4.21.6 L0 Troubleshooting

Situation 1: L0 error appears immediately after the outdoor unit is switched-on

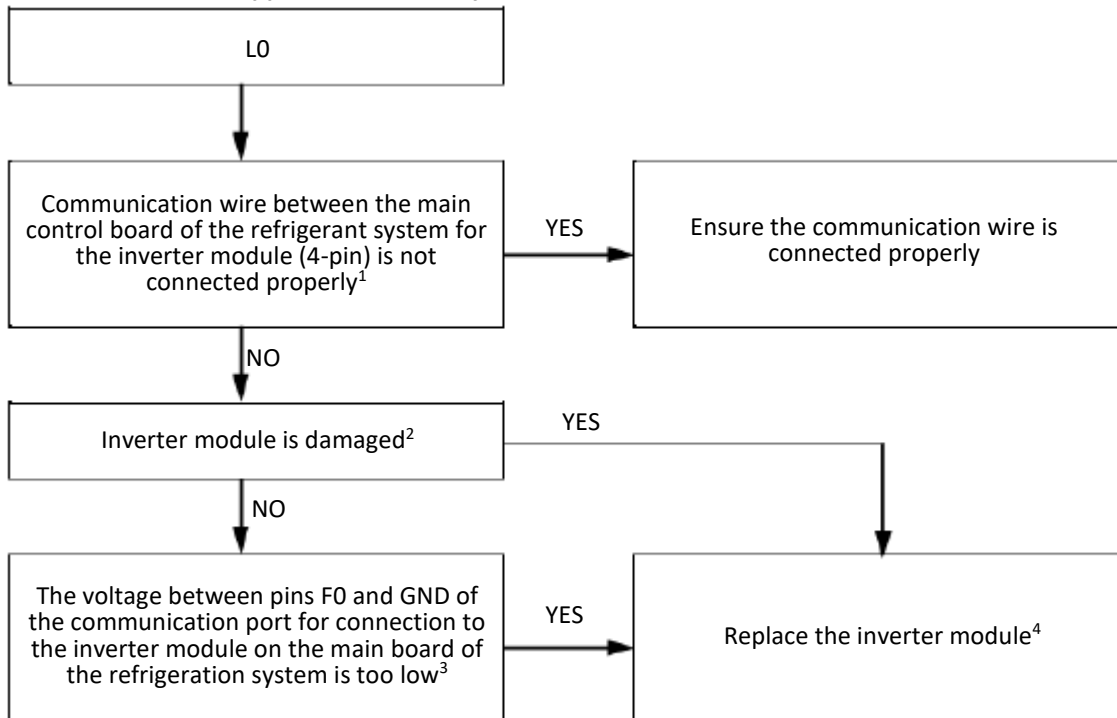

Notes:

1. For MiSAN-YEE 1 S 6.1-8.1 three-phase, the communication port between the main control board of the refrigerant system and the inverter module of the refrigerant system is: port CN36 on the main control board of the refrigerant system and port CN8 on the inverter module of the refrigerant system.
2. Measure the resistance between each of U, V and W and each of P and N on the inverter module. All the resistances should be infinite. If any of them are not infinite, the inverter module is damaged and should be replaced.
3. The normal voltage between F0 and GND is 5V. Refer to Figure 4-4.6.
4. When replacing an inverter module, a layer of thermally conductive silica gel should be painted on the IPM module, IGBT, diode, bridge rectifier (on the reverse side of the inverter module PCB). Refer to Figure 4-4.2.

Figure 4-4.6: Voltage F0 and GND on IC28-1 (F0) , IC28-4 (GND)

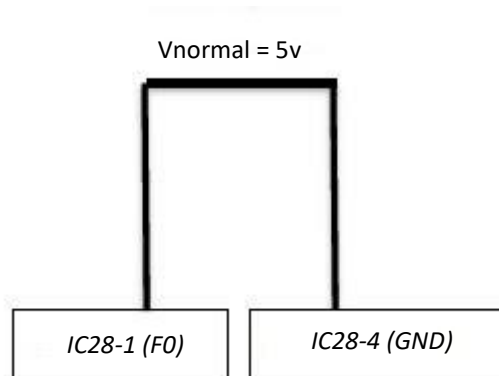

Situation 2: L0 error appears immediately after the compressor starts up

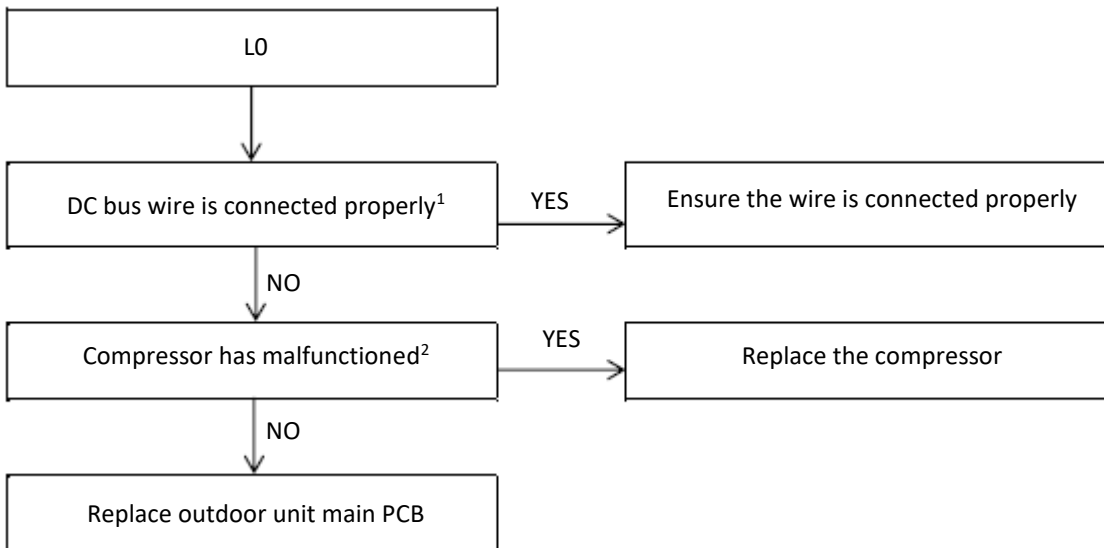

- Notes:
1. The DC bus wire must run from terminal N on the inverter module, through the current sensor (indicated by the arrow on the current sensor) and end at terminal N on the capacitor. Refer to Figure 4-4.7.

Figure 4-4.7: DC bus wire connection (L1L2L3, PIN-POUT)

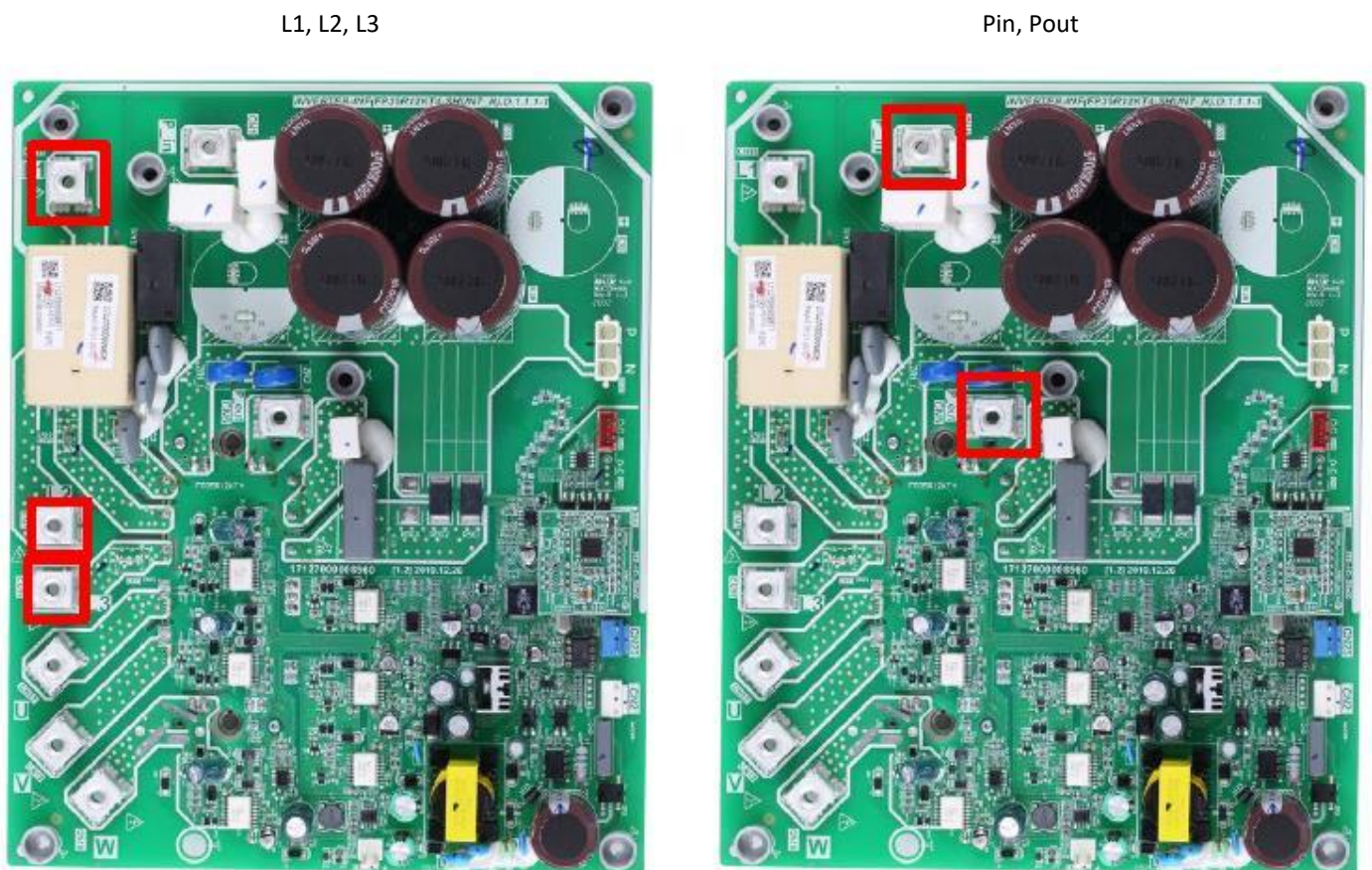

2. The normal resistances of the inverter compressor are 0.7-1.5Ω among U V W and infinite between each of U V W and ground. If any of the resistances differ from these specifications, the compressor has malfunctioned.

Situation 3: L0 error appears within 2 seconds of compressor start-up

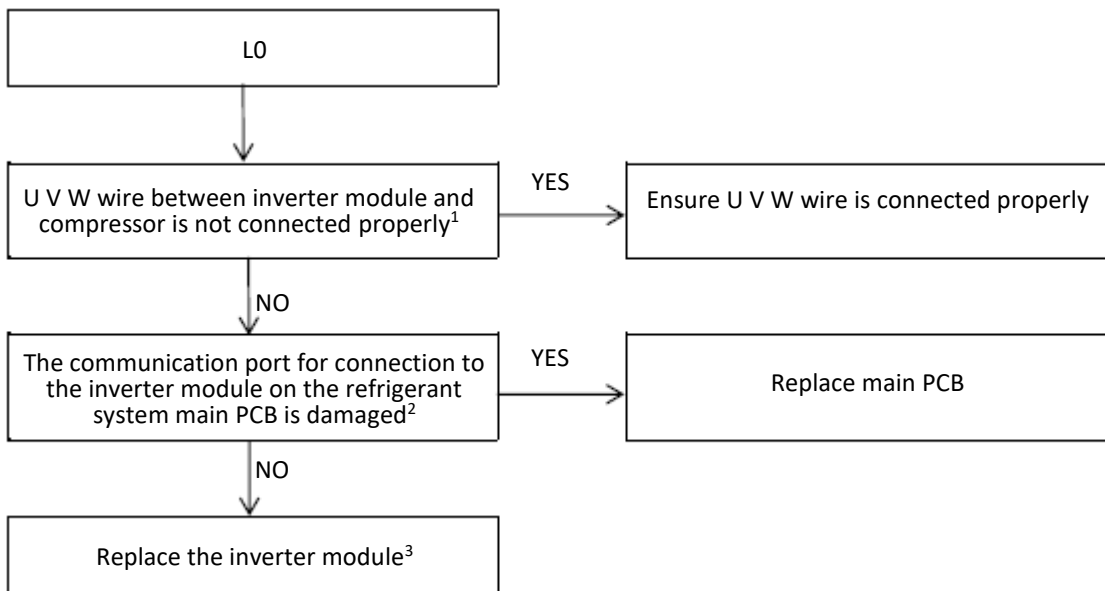

- Notes:
1. Connect the U V W wire from the inverter module to the correct compressor terminals, as indicated by the labels on the compressor
 2. Measure the voltage between W-, W+, V-, V+, U-, U+ and GND when the unit is in standby. The normal voltage should be 2.5 V-4 V and the six voltages should be the same, otherwise the communication terminal is faulty. Refer to Figure 4-4.8.

Figure 4-4.8: Inverter module connection port

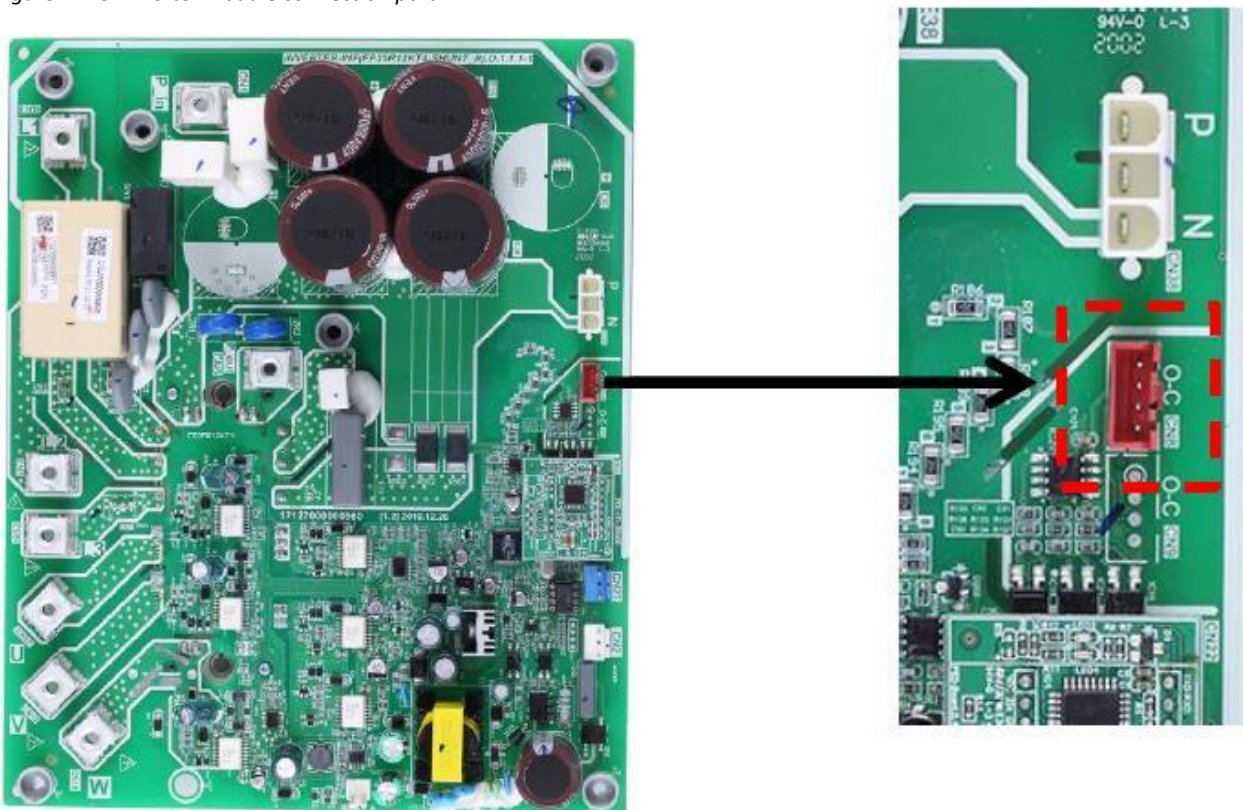

3. When replacing an inverter module, a layer of thermally conductive silica gel should be painted on the IPM module (on the reverse side of the inverter module PCB). Refer to Figure 4-4.2.

Situation 4: LO error appears after the compressor has been running for a period of time and the compressor speed is over 60 rps

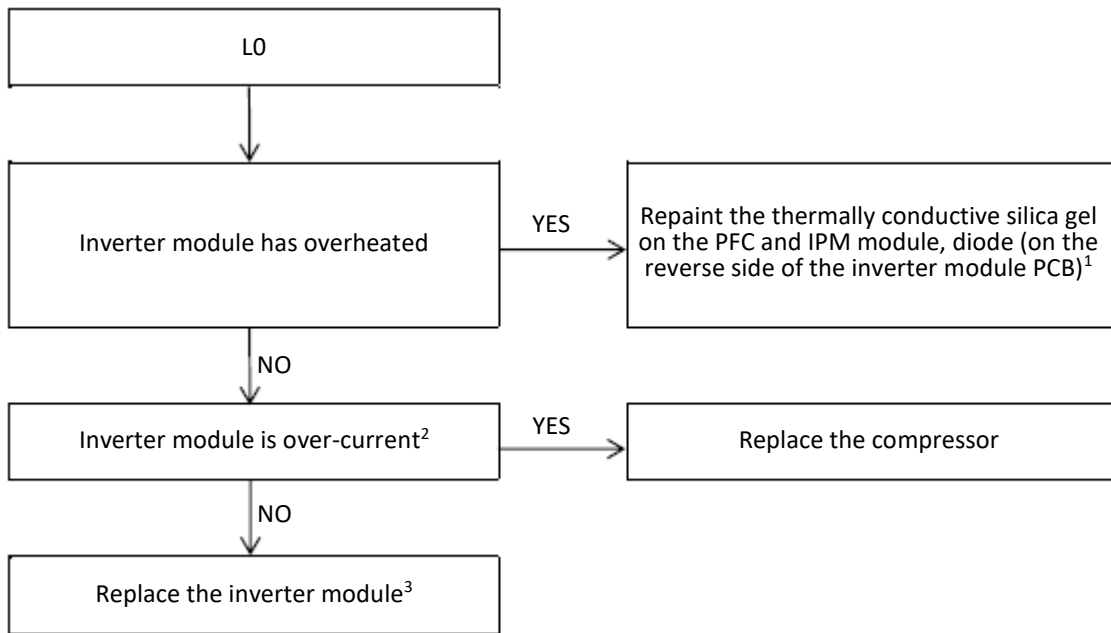

- Notes:
1. When replacing an inverter module, a layer of thermally conductive silica gel should be painted on the IPM module (on the reverse side of the inverter module PCB).
 2. Use clip-on ammeter to measure the compressor current, if the current is normal indicates the inverter module is faulty, if the current is abnormal indicates the compressor is faulty.

Situation 5: LO error appears occasionally/irregularly

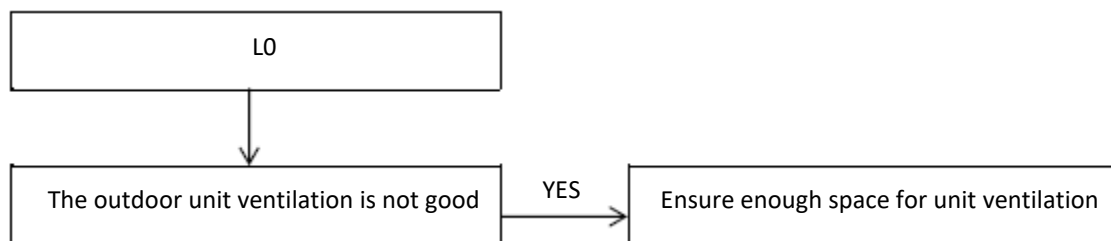

4.21.7 L1/L2 Troubleshooting

The normal DC voltage between terminals P and N on the inverter module is 540V. If the voltage is lower than 300V, the unit displays an L1 error. If the voltage is higher than 830V, the unit displays an L2 error. Refer to Figure 4-4.9.

Figure 4-4.9: Voltage terminals P,N

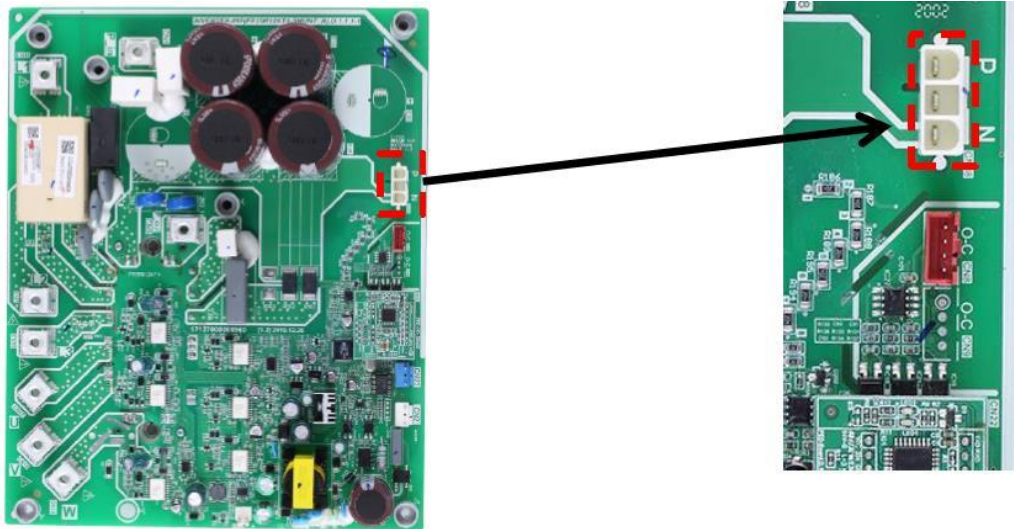

$$V_{\text{normal}} = 540\text{V DC}$$

Situation 1: L1 or L2 error appears immediately after the outdoor unit is switched-on

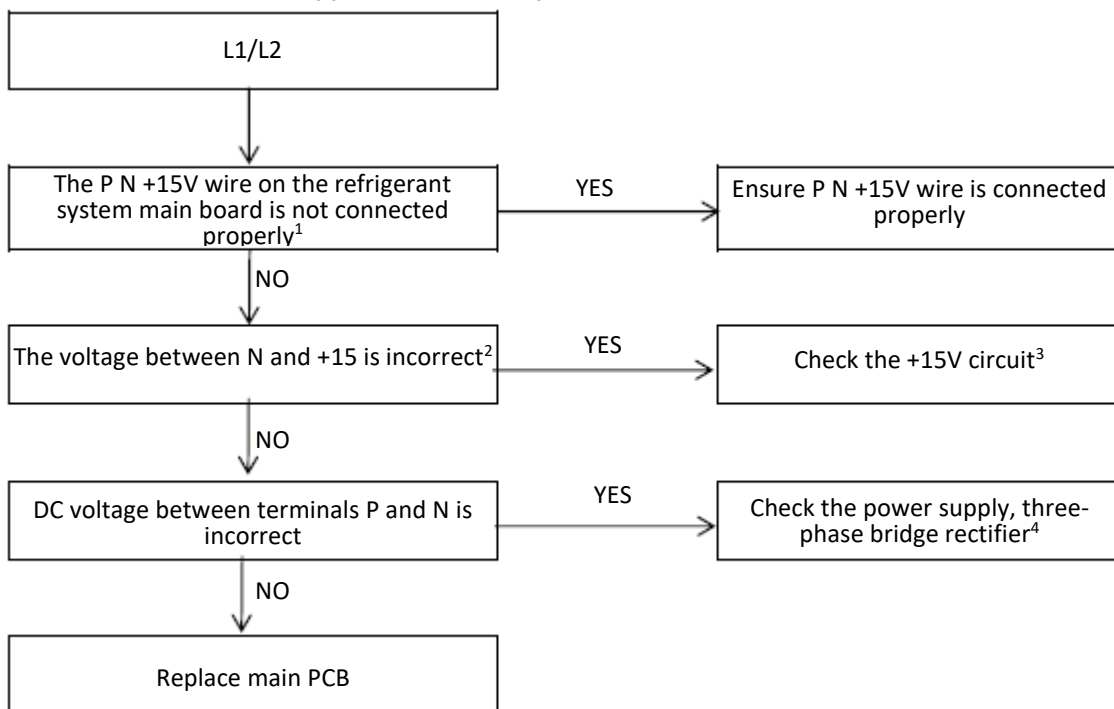

Notes:

1. Terminal P N +15V on the refrigerant system main board. Refer to Figure 4-4.9
2. Voltage between N and +15. Refer to Figure 4-4.10

Figure 4-4.10: P N +15V Terminal -+15V IC4/5/6PIN12 ; N- (IC/4/5,6) PIN13



3. Check the +15V circuit according to the corresponding wiring diagram. If the output power supply of the inverter module in IC4/5/6PIN12 is not +15V, the inverter module is faulty. If the output power supply of the inverter module is +15V, the main PCB is faulty.
4. Check the bridge rectifier using one of the two following methods (refer to Figure 4-4.11)
 - Method 1: measure the resistance between two of the 5 bridge rectifier terminals. If one of the heaters is close to zero, the bridge rectifier is faulty.
 - Method 2: use a multimeter to set the diode:
 - put the red probe on the negative DC power output terminal (terminal 5) and put the black probe on each of the AC power input terminals (terminals 1, 2 and 3) in turn. The voltage between terminal 5 and each of terminals 1, 2 and 3 should be approximately 0.378 V. If the voltage is 0, the bridge rectifier is faulty.
 - put the red probe on the positive DC power output terminal (terminal 4) and put the black probe on each of the AC power input terminals (terminals 1, 2 and 3) in turn. The voltage between terminal 4 and each of terminals 1, 2 and 3 should be infinite. If the voltage is 0, the bridge rectifier is faulty.

Figure 4-4.11: Bridge rectifier

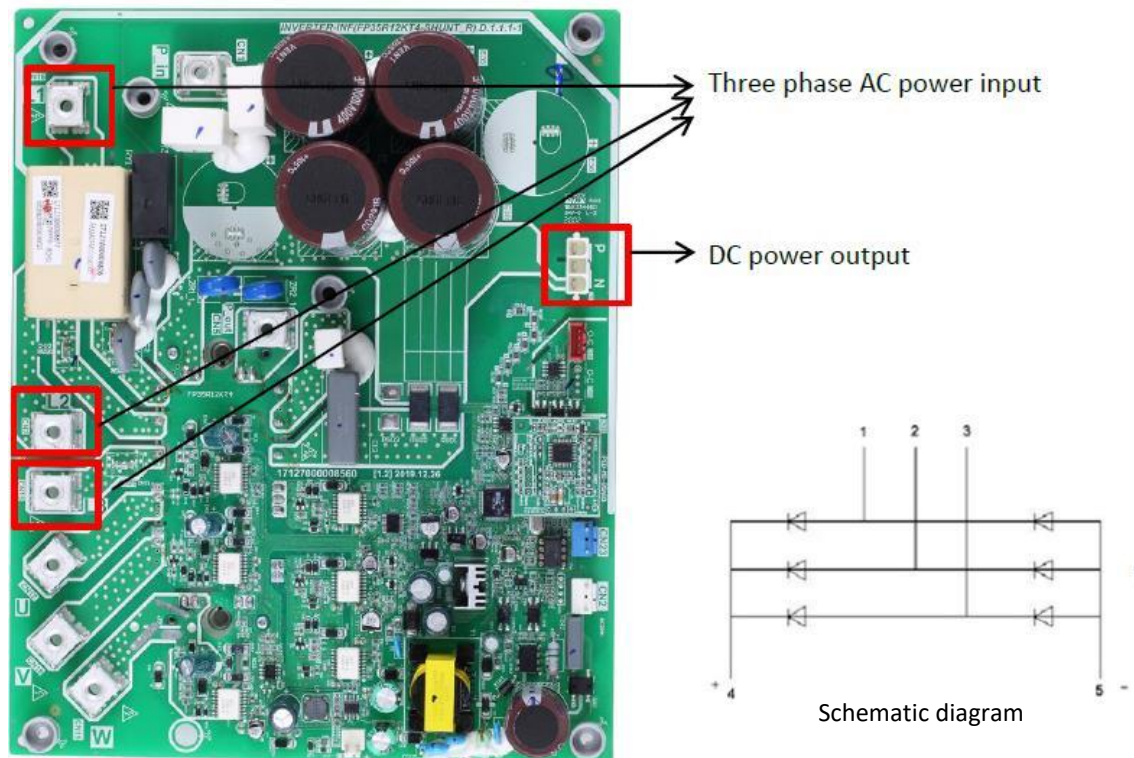

4.21.8 L4 Troubleshooting

Situation 1: L4 error appears immediately after the outdoor unit is switched-on

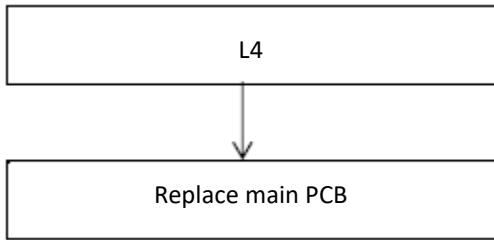

Situation 2: L4 error appears after the compressor has been running for a period of time and the compressor speed is over 60 rps

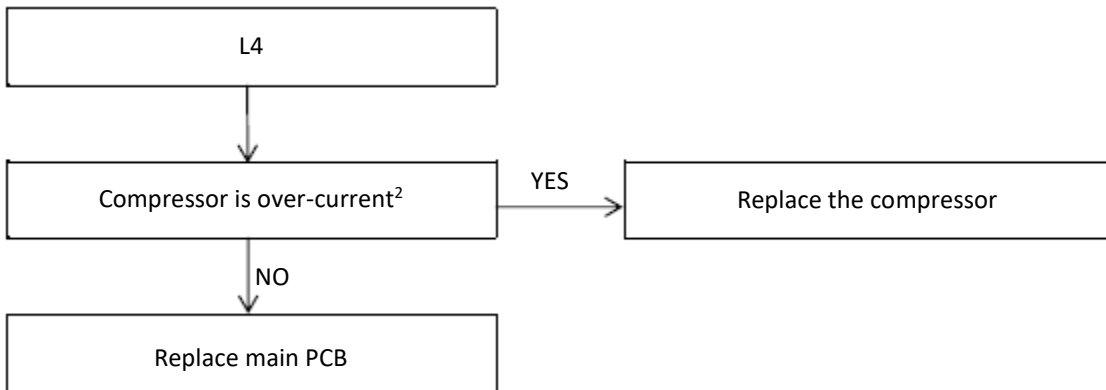

Notes:

1. Restart the unit, use clamp ammeter to measure the compressor current, if the current is normal indicates the compressor is faulty, if the current is abnormal indicates the inverter PCB is faulty.

4.21.9 L5/L8/L9 Troubleshooting

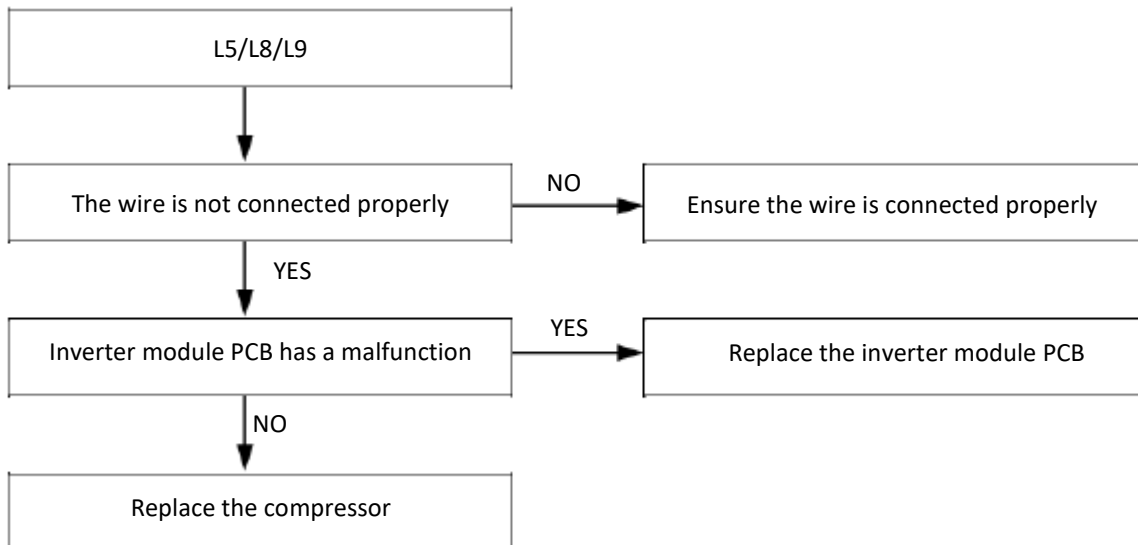

4.22 Pd Troubleshooting

4.22.1 Digital display output



4.22.2 Description

- High temperature protection of air side heat exchanger refrigerant outlet in cooling mode. When the air side heat exchanger refrigerant outlet temperature is higher than 61°C for more than 3 seconds, the system displays Pd protection and the unit stops running. When the air side heat exchanger refrigerant outlet temperature returns drops below 55°C, Pd is removed and normal operation resumes.
- The unit stops running.
- Error code is displayed on outdoor unit main PCB and user interface.

4.22.3 Possible causes

- Temperature sensor not connected properly or has malfunctioned.
- Poor condenser heat exchange.
- Fan motor damaged.
- Indoor unit main PCB damaged.

4.22.4 Procedure

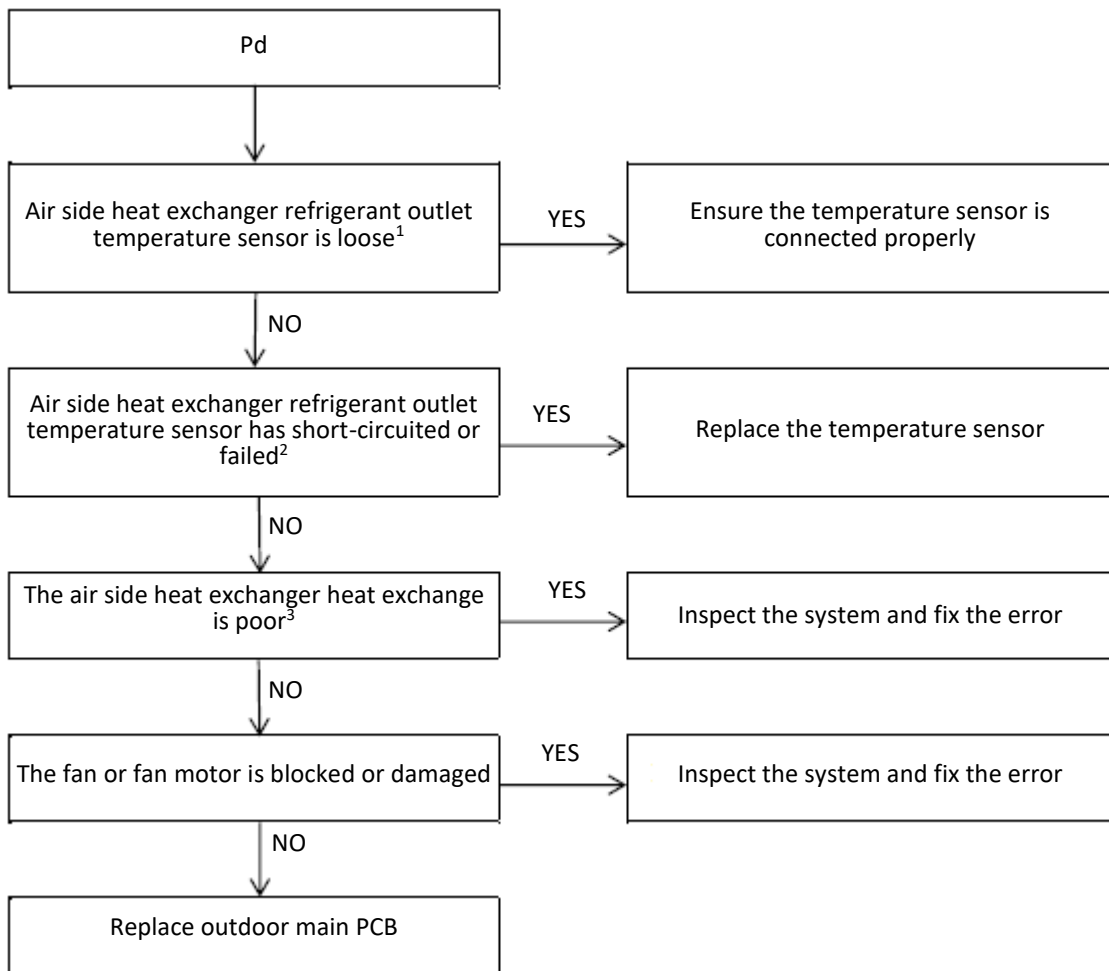

Notes:

1. Air side heat exchanger refrigerant outlet temperature sensor and outdoor ambient temperature sensor connections are port CN9 on the outdoor unit main PCB single-phase MiSAN-YEE 1 S. 2.1-5.1 (labelled 12 in Figure 4-2.2 in Part 4, 2.3 “Main PCBs for Refrigerant System, Inverter Module”), port CN9 on the outdoor unit refrigerant system main PCB single-phase MiSAN-YEE 1 S. 5.1-6.1 (labelled 12 in Figure 4-2.3 in Part 4, 2.3 “Main PCBs for Refrigerant System, Inverter Module”), port CN9 on the outdoor unit refrigerant system main PCB three-phase MiSAN-YEE 1 S. 6.1-8.1 (labelled 17 in Figure 4-2.4 in Part 4, 2.3 “Main PCBs for Refrigerant System, Inverter Module”).
2. Measure sensor resistance. If the resistance is too low, the sensor has short-circuited. If the resistance is not consistent with the sensor’s resistance characteristics table, the sensor has failed. Refer to Part 2, 1.1 “Outdoor unit Layout” and to Table 4-5.1 in Part 4, 5.1 “Temperature Sensor Resistance Characteristics”.
3. Check air side heat exchanger, fan and air outlets for dirt/blockages.
4. The HP pressure switch connection is port CN13

4.23 PP Troubleshooting

4.23.1 Digital display output

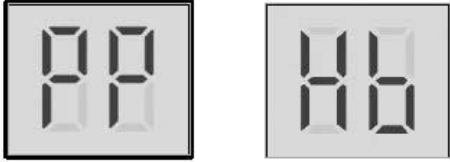

4.23.2 Description

- Water side heat exchanger inlet temperature is higher than outlet temperature in heating mode.
- The unit stops running.
- Error code is displayed on indoor unit main PCB and user interface.
- Hb indicates that PP has been displayed 3 times.

4.23.3 Possible causes

- Temperature sensor not connected properly or has malfunctioned.
- 4-way valve is blocked or damaged.
- Indoor unit main PCB damaged.

4.23.4 Procedure

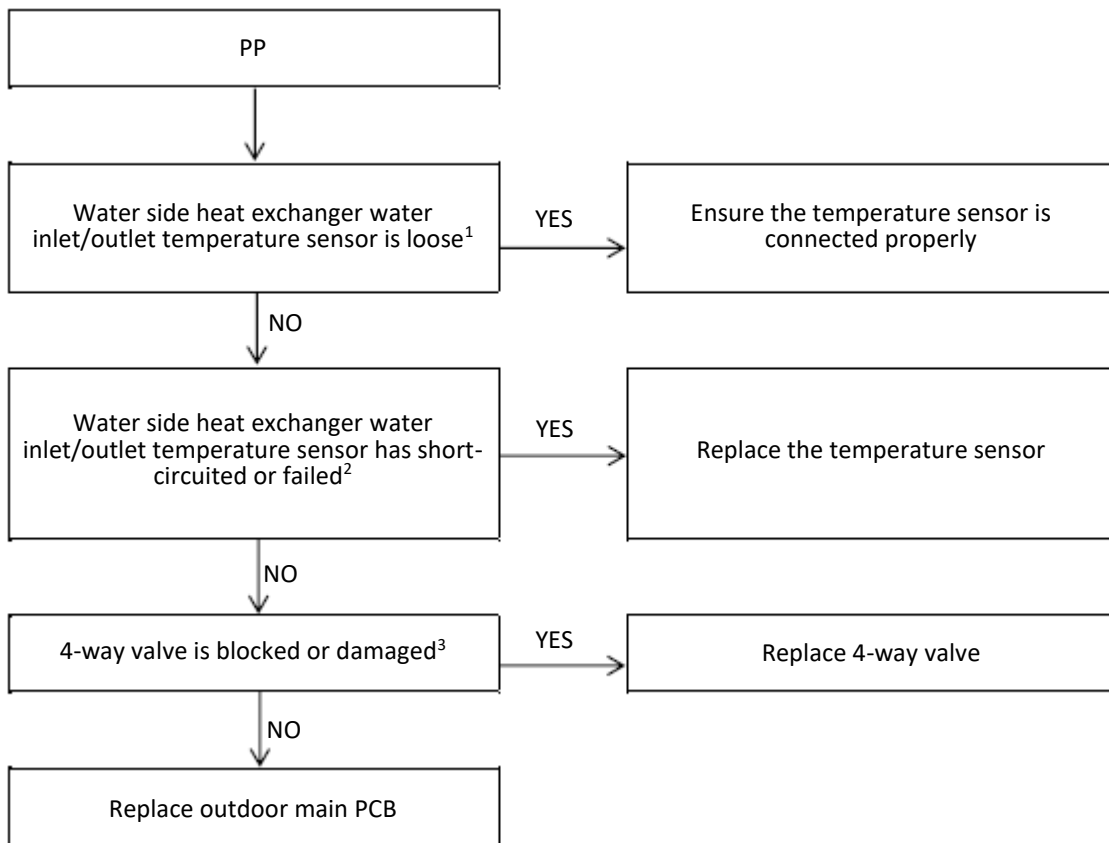

Notes:

1. Water side heat exchanger water inlet temperature sensor and water side heat exchanger water outlet temperature sensor connections are port CN6 on the Indoor unit electric control box main PCB (labelled 1 in Figure 4-2.1 in Part 4, 2.2 "Main PCB for Hydronic System").
2. Measure sensor resistance. If the resistance is too low, the sensor has short-circuited. If the resistance is not consistent with the sensor's resistance characteristics table, the sensor has failed. Refer to Part 2, 1.2 "Indoor unit Layout" and to Tables 4-5.1 and 4-5.2 in Part 4, 5.1 "Temperature Sensor Resistance Characteristics".
3. Restart the unit in cooling mode to change the refrigerant flow direction. If the unit does not operate normally, the 4-way valve is blocked or damaged.

4.24 C7 Troubleshooting

4.24.1 Digital display output



4.24.2 Description

- Transducer module temperature too high
- The unit stops running.
- Error code is displayed on indoor unit main PCB and user interface.

4.24.3 Possible causes

- The unit's power supply voltage is low.
- The space between the units is too narrow for the heat exchanger.
- The heat exchanger is dirty or something is stuck on the surface.
- Fan not working.
- Water flow is insufficient.
- Water outlet temperature sensor loose or faulty.

4.24.4 Procedure

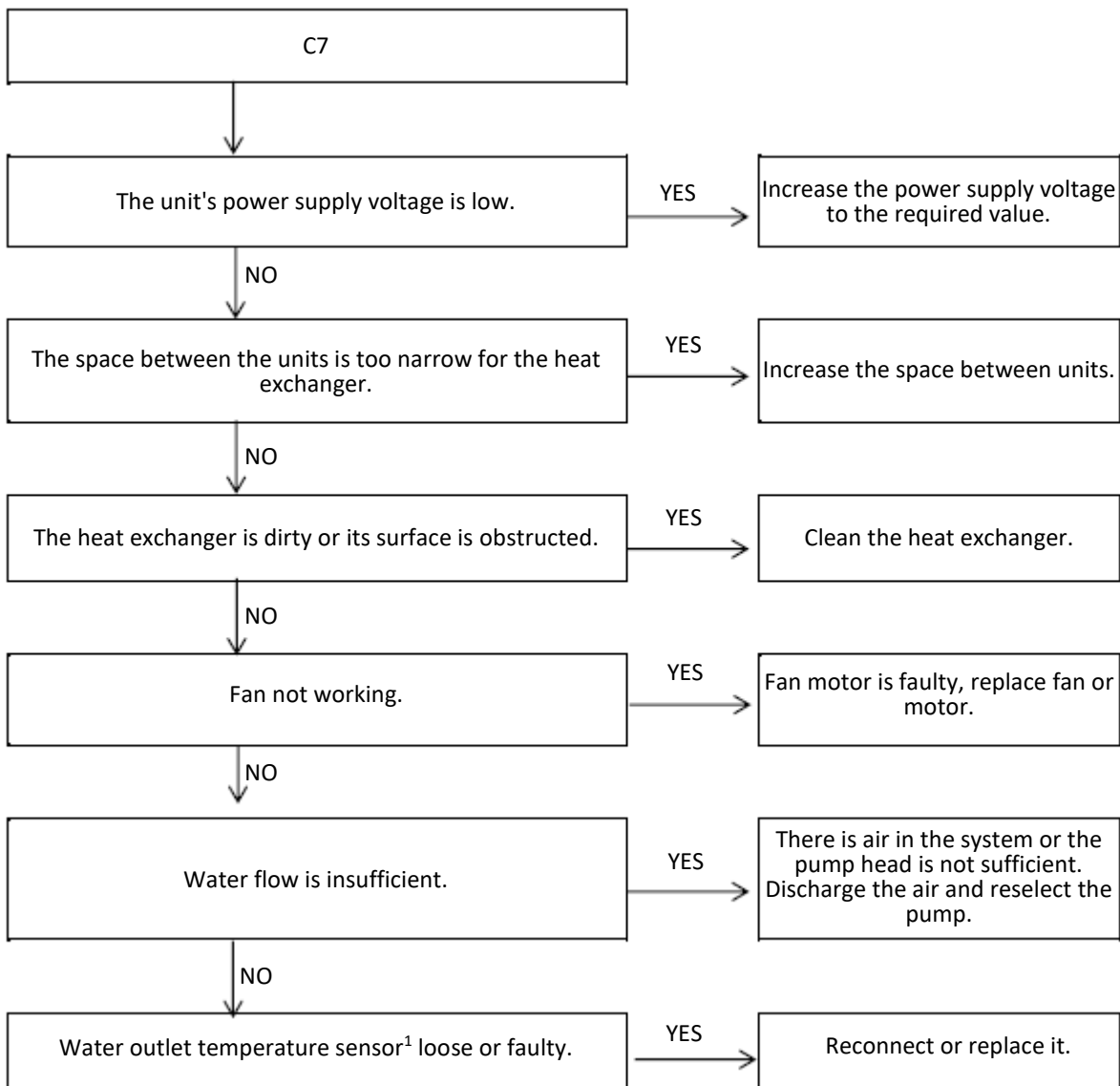

Notes:

1. Water side heat exchanger water inlet temperature sensor and water side heat exchanger water outlet temperature sensor connections are port CN6 on the indoor unit main PCB (labelled 10 in Figure 4-2.1 in Part 4, 2.2 "Main PCB for Hydronic System").
2. Measure sensor resistance. If the resistance is too low, the sensor has short-circuited. If the resistance is not consistent with the sensor's resistance characteristics table, the sensor has failed. Refer to Part 2, 1.2 "Indoor unit Layout" and to Table 4-5.3 in Part 4, 5.1 "Temperature Sensor Resistance Characteristics".

4.25 bH Troubleshooting

4.25.1 Digital display output



4.25.2 Description

- PED PCB failure
- The unit stops running.
- Error code is displayed on indoor unit main PCB and user interface.

4.25.3 Possible causes

- Power supply problem.
- PED board faulty.
- IPM module faulty.

4.25.4 Procedure

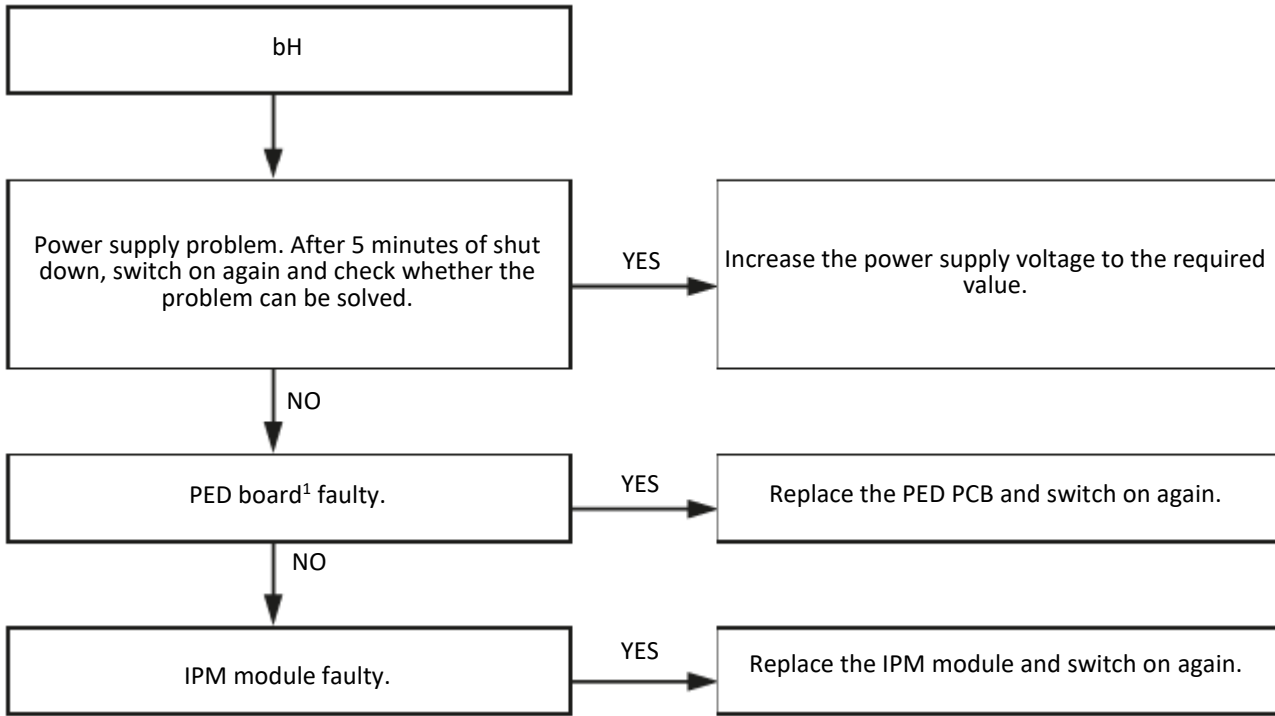

Notes:

1. PED is port CN22 on the indoor hydronic unit main PCB (labelled 11 Figure 4-2.7 hydronic: Outdoor unit inverter module three-phase MiSAN- YEE 1 S 6.1-8.1).

4.26 Pb Troubleshooting

4.26.1 Digital display output



4.26.2 Description

- Water side heat exchanger anti-freeze protection.
- The unit stops running.
- Error code is displayed on indoor unit main PCB and ANTI.FREEZE icon is displayed on user interface.

4.26.3 Possible causes

- Normal system protection.
- Temperature sensor not connected properly or has malfunctioned.
- Indoor unit main PCB damaged.

4.26.4 Procedure

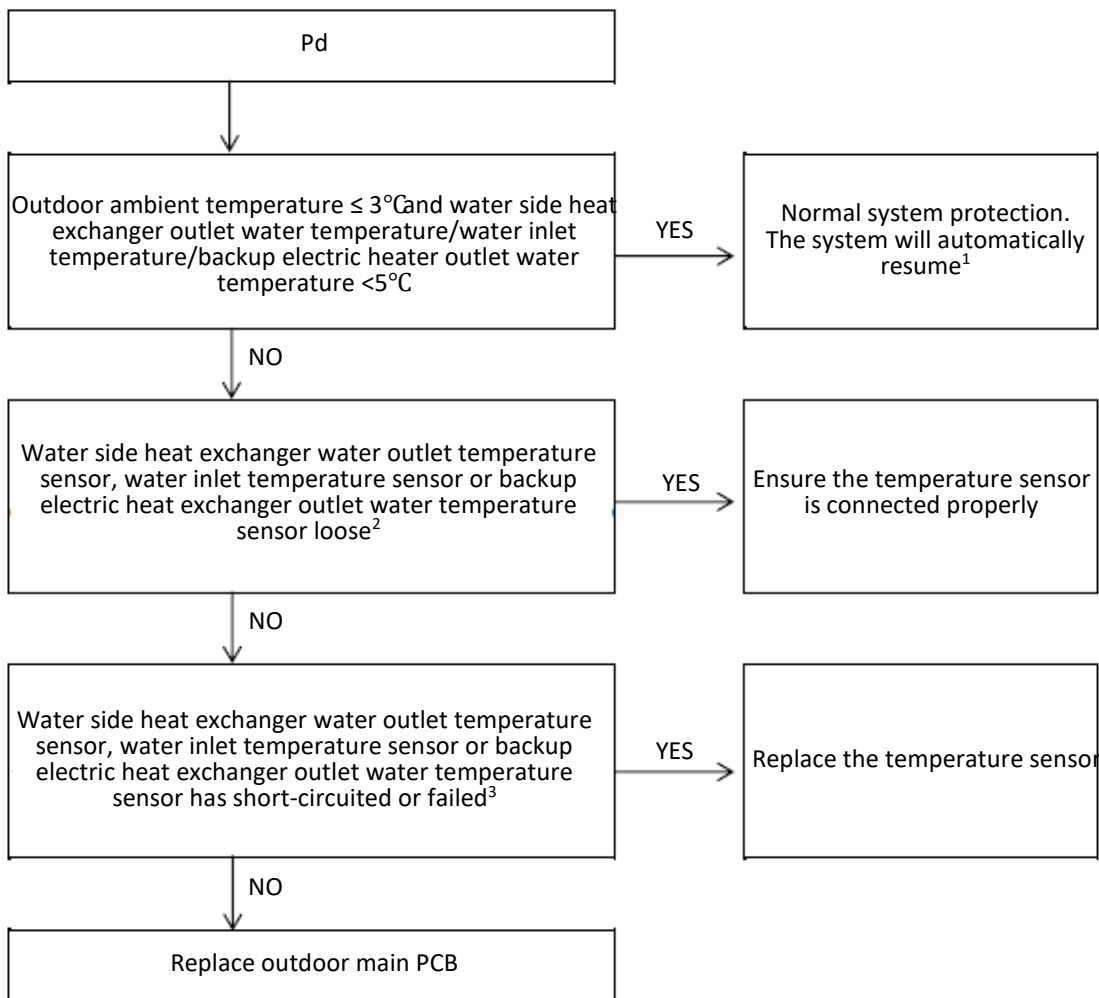

Notes:

1. Refer to Part 3, 5.7 "Water side heat exchanger anti-freeze protection control".
2. Backup electric heat exchanger water outlet temperature sensor, water side heat exchanger water outlet temperature sensor and water side heat exchanger water outlet temperature sensor connections are port CN6 on the hydronic box main PCB (labelled 10 in Figure 4-2.1 in Part 4, 2.2 "Main PCB for Hydronic System").
3. Measure sensor resistance. If the resistance is too low, the sensor has short-circuited. If the resistance is not consistent with the sensor's resistance characteristics table, the sensor has failed. Refer to Part 2, 1.2 "Indoor unit Layout" and to Table 4-5.3 in Part 4, 5.1 "Temperature Sensor Resistance Characteristics".

5 Temperature Sensor Resistance Characteristics

Table 4-5.1: Outdoor ambient temperature sensor, water side heat exchanger refrigerant inlet/outlet (liquid/gas pipe) temperature sensor, air side heat exchanger refrigerant outlet temperature sensor and suction pipe temperature sensor resistance characteristics

Temperature (°C)	Resistance (kΩ)	Temperature (°C)	Resistance (kΩ)	Temperature (°C)	Resistance (kΩ)	Temperature (°C)	Resistance (kΩ)
-25	144.266	15	16.079	55	2.841	95	0.708
-24	135.601	16	15.313	56	2.734	96	0.686
-23	127.507	17	14.588	57	2.632	97	0.666
-22	119.941	18	13.902	58	2.534	98	0.646
-21	112.867	19	13.251	59	2.44	99	0.627
-20	106.732	20	12.635	60	2.35	100	0.609
-19	100.552	21	12.05	61	2.264	101	0.591
-18	94.769	22	11.496	62	2.181	102	0.574
-17	89.353	23	10.971	63	2.102	103	0.558
-16	84.278	24	10.473	64	2.026	104	0.542
-15	79.521	25	10	65	1.953	105	0.527
-14	75.059	26	9.551	66	1.883		
-13	70.873	27	9.125	67	1.816		
-12	66.943	28	8.721	68	1.752		
-11	63.252	29	8.337	69	1.69		
-10	59.784	30	7.972	70	1.631		
-9	56.524	31	7.625	71	1.574		
-8	53.458	32	7.296	72	1.519		
-7	50.575	33	6.982	73	1.466		
-6	47.862	34	6.684	74	1.416		
-5	45.308	35	6.401	75	1.367		
-4	42.903	36	6.131	76	1.321		
-3	40.638	37	5.874	77	1.276		
-2	38.504	38	5.63	78	1.233		
-1	36.492	39	5.397	79	1.191		
0	34.596	40	5.175	80	1.151		
1	32.807	41	4.964	81	1.113		
2	31.12	42	4.763	82	1.076		
3	29.528	43	4.571	83	1.041		
4	28.026	44	4.387	84	1.007		
5	26.608	45	4.213	85	0.974		
6	25.268	46	4.046	86	0.942		
7	24.003	47	3.887	87	0.912		
8	22.808	48	3.735	88	0.883		
9	21.678	49	3.59	89	0.855		
10	20.61	50	3.451	90	0.828		
11	19.601	51	3.318	91	0.802		
12	18.646	52	3.191	92	0.777		
13	17.743	53	3.069	93	0.753		
14	16.888	54	2.952	94	0.73		

Table: Compressor discharge pipe temperature sensor resistance characteristics

Temperature (°C)	Resistance (kΩ)	Temperature (°C)	Resistance (kΩ)	Temperature (°C)	Resistance (kΩ)	Temperature (°C)	Resistance (kΩ)
-20	542.7	20	68.66	60	13.59	100	3.702
-19	511.9	21	65.62	61	13.11	101	3.595
-18	483.0	22	62.73	62	12.65	102	3.492
-17	455.9	23	59.98	63	12.21	103	3.392
-16	430.5	24	57.37	64	11.79	104	3.296
-15	406.7	25	54.89	65	11.38	105	3.203
-14	384.3	26	52.53	66	10.99	106	3.113
-13	363.3	27	50.28	67	10.61	107	3.025
-12	343.6	28	48.14	68	10.25	108	2.941
-11	325.1	29	46.11	69	9.902	109	2.860
-10	307.7	30	44.17	70	9.569	110	2.781
-9	291.3	31	42.33	71	9.248	111	2.704
-8	275.9	32	40.57	72	8.940	112	2.630
-7	261.4	33	38.89	73	8.643	113	2.559
-6	247.8	34	37.30	74	8.358	114	2.489
-5	234.9	35	35.78	75	8.084	115	2.422
-4	222.8	36	34.32	76	7.820	116	2.357
-3	211.4	37	32.94	77	7.566	117	2.294
-2	200.7	38	31.62	78	7.321	118	2.233
-1	190.5	39	30.36	79	7.086	119	2.174
0	180.9	40	29.15	80	6.859	120	2.117
1	171.9	41	28.00	81	6.641	121	2.061
2	163.3	42	26.90	82	6.430	122	2.007
3	155.2	43	25.86	83	6.228	123	1.955
4	147.6	44	24.85	84	6.033	124	1.905
5	140.4	45	23.89	85	5.844	125	1.856
6	133.5	46	22.89	86	5.663	126	1.808
7	127.1	47	22.10	87	5.488	127	1.762
8	121.0	48	21.26	88	5.320	128	1.717
9	115.2	49	20.46	89	5.157	129	1.674
10	109.8	50	19.69	90	5.000	130	1.632
11	104.6	51	18.96	91	4.849		
12	99.69	52	18.26	92	4.703		
13	95.05	53	17.58	93	4.562		
14	90.66	54	16.94	94	4.426		
15	86.49	55	16.32	95	4.294		
16	82.54	56	15.73	96	4.167		
17	78.79	57	15.16	97	4.045		
18	75.24	58	14.62	98	3.927		
19	71.86	59	14.09	99	3.812		

Table 4-5.3: Water side heat exchanger water inlet/outlet temperature sensor, backup heat exchanger outlet water temperature sensor and DHW temperature sensor resistance characteristics

Temperature (°C)	Resistance (kΩ)	Temperature (°C)	Resistance (kΩ)	Temperature (°C)	Resistance (kΩ)	Temperature (°C)	Resistance (kΩ)
-30	867.29	10	98.227	50	17.600	90	4.4381
-29	815.80	11	93.634	51	16.943	91	4.3022
-28	767.68	12	89.278	52	16.315	92	4.1711
-27	722.68	13	85.146	53	15.713	93	4.0446
-26	680.54	14	81.225	54	15.136	94	3.9225
-25	641.07	15	77.504	55	14.583	95	3.8046
-24	604.08	16	73.972	56	14.054	96	3.6908
-23	569.39	17	70.619	57	13.546	97	3.5810
-22	536.85	18	67.434	58	13.059	98	3.4748
-21	506.33	19	64.409	59	12.592	99	3.3724
-20	477.69	20	61.535	60	12.144	100	3.2734
-19	450.81	21	58.804	61	11.715	101	3.1777
-18	425.59	22	56.209	62	11.302	102	3.0853
-17	401.91	23	53.742	63	10.906	103	2.9960
-16	379.69	24	51.396	64	10.526	104	2.9096
-15	358.83	25	49.165	65	10.161	105	2.8262
-14	339.24	26	47.043	66	9.8105		
-13	320.85	27	45.025	67	9.4736		
-12	303.56	28	43.104	68	9.1498		
-11	287.33	29	41.276	69	8.8387		
-10	272.06	30	39.535	70	8.5396		
-9	257.71	31	37.878	71	8.2520		
-8	244.21	32	36.299	72	7.9755		
-7	231.51	33	34.796	73	7.7094		
-6	219.55	34	33.363	74	7.4536		
-5	208.28	35	31.977	75	7.2073		
-4	197.67	36	30.695	76	6.9704		
-3	187.66	37	29.453	77	6.7423		
-2	178.22	38	28.269	78	6.5228		
-1	168.31	39	27.139	79	6.3114		
0	160.90	40	26.061	80	6.1078		
1	152.96	41	25.031	81	5.9117		
2	145.45	42	24.048	82	5.7228		
3	138.35	43	23.109	83	5.5409		
4	131.64	44	22.212	84	5.3655		
5	125.28	45	21.355	85	5.1965		
6	119.27	46	20.536	86	5.0336		
7	113.58	47	19.752	87	4.8765		
8	108.18	48	19.003	88	4.7251		
9	103.07	49	18.286	89	4.5790		

6 Control keypad



Keys		Function
	MENU	To open the various menus from the HOME screen.
	ON / OFF	Turn on/off heating and cooling modes or DHW mode Turn on/off functions in the menu structure
	UNLOCK	(press for 3 sec.) Unlock/lock the keypad
	OK	Enter a sub-menu Confirm the values entered
	LEFT - RIGHT DOWN - UP	To move through the menu structure, to adjust parameter settings
	BACK	To go back to the higher level

There is a FOR SERVICEMAN menu available for installers to:

- Configure the system composition
- Configure parameters

How to access reserved functions

Go to MENU > FOR SERVICEMAN Press OK

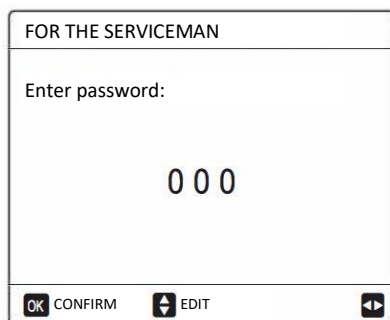

Enter password=234

FOR SERVICEMAN		1/3
1. DHW MODE SETTING	OK	ENTER
2. COOL MODE SETTING		
3. HEAT MODE SETTING		
4. AUTO MODE SETTING		
5. TEMP. TYPE SETTING		
6. ROOM THERMOSTAT		

FOR SERVICEMAN		2/3
7. OTHER HEATING SOURCE	OK	ENTER
8. HOLIDAY AWAY SETT.		
9. SERVICE CALL		
10. RESET FACTORY SETTINGS		
11. TEST MODE		
12. SPECIAL FUNCTION		

FOR SERVICEMAN		3/3
13. AUTO RESTART	OK	ENTER
14. POWER INPUT LIMIT		
15. INPUT DEFINITION		
16. CASC. SETT.		
17. HMI ADDRESS SET		



CLIVET SPA

Via Camp Lonc 25, Z.I. Villapaiera

32032 Feltre (BL) - Italy

Tel. +39 0439 3131 - Fax +39 0439 313300

info@clivet.it

www.clivet.com

MideaGroup
humanizing technology