

Data sheet

Oil separator

Type OUB



Oil separator type OUB is for use in all refrigeration plants where the compressor lubricating oil must be returned directly to the compressor oil sump under all operating conditions.

In this way lubricating oil from the compressor is prevented from circulating with the refrigerant in the refrigeration system itself.

Features

- Ensures oil return to compressor oil sump. Prevents compressor breakdown caused by lack of lubrication. Increases compressor operating life
- High efficiency
Due to the interaction of reduced flow velocity, change of flow direction for oil concentration, collection of separated oil at high temperatures, and automatic oil return to the crankcase
- Protects against liquid hammer in the compressor
- Better utilisation of condenser and evaporator capacity (no oil-gas collection)
- Pulsation and noise damping on the high-pressure side of system
- OUB 1 may be used in the following EX range: Category 3 (Zone 2)

Approvals

UL listed, file 3736
CSA certified, LR51840

EAC
CE

Data sheet | Oil separator, type OUB

Technical data

Refrigerants	R22, R134a, R290 **, R404A, R407A, R407C, R407F, R407H, R438A, R448A, R449A, R449B, R450A, R452A, R454A *, R454C *), R455A *), R507A, R513A, R600 **, R600a **), R1234ze *), R1270 **)
Max. working pressure	PS/MWP = 28 bar
Max. test pressure	Pe = 40 bar
Temperature of medium	-40 – 120 °C
Net volume	OUB 1: 0.52 l
	OUB 4: 2.46 l
Oil reservoir	OUB 1: 0.1 l
	OUB 4: 0.5 l
Recommended tightening torque of unions	OUB 1: 40 Nm
	OUB 4: 90 Nm

OUB 1 is evaluated for R454A, R454C, R455A, R1234ze by ignition source assessment in accordance with standard EN ISO80079-36.

OUB 1s is evaluated for R290, R454A, R454C, R455A, R600, R600a, R1234ze, R1270 by ignition source assessment in accordance with standard EN ISO80079-36. Flare connections are only approved for A1 and A2L refrigerants.

For complete list of approved refrigerants, visit www.products.danfoss.com and search for individual code numbers, where refrigerants are listed as part of technical data.

Ordering

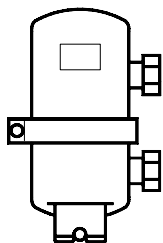

OUB 1 / OUB 4

Type	Connection			Rated plant capacity [kW]					Code no. for OUB + unions (straightway)
	[in]	[mm]	Version	R22	R134a	R404A	R507	R407C	
OUB 1	3/8	10	Flare	3.1	2.5	3.5	3.5	4.4	040B0010 + 2 × 040B0132
	3/8	–	Solder	3.1	2.5	3.5	3.5	4.4	040B0010 + 2 × 040B0140
	1/2	12	Flare	3.1	2.5	3.5	3.5	4.4	040B0010 + 2 × 040B0134
	1/2	–	Solder	3.1	2.5	3.5	3.5	4.4	040B0010 + 2 × 040B0142
	5/8	16	Flare	3.1	2.5	3.5	3.5	4.4	040B0010 + 2 × 040B0136
	5/8	16	Solder	3.1	2.5	3.5	3.5	4.4	040B0010 + 2 × 040B0144
Without connection unions									040B0010
OUB 4	5/8	16	Flare	11.6	9.6	12.8	12.8	16.0	040B0040 + 2 × 040B0256
	5/8	16	Solder	11.6	9.6	12.8	12.8	16.0	040B0040 + 2 × 040B0266
	3/4	–	Solder	11.6	9.6	12.8	12.8	16.0	040B0040 + 2 × 040B0268
	7/8	–	Solder	11.6	9.6	12.8	12.8	16.0	040B0040 + 2 × 040B0270
	1 1/8	–	Solder	11.6	9.6	12.8	12.8	16.0	040B0040 + 2 × 040B0274
Without connection unions									040B0040

OUB 1s

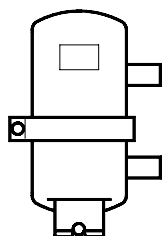

Type	Connection		Rated plant capacity [kW]					Code no. for OUB + unions (straightway)
	[mm]	Version	R22	R134a	R404A	R507	R407C	
OUB 1s ¹⁾	10	Solder	3.1	2.5	3.5	3.5	4.4	040B0023
OUB 1s ²⁾	10	Solder	3.1	2.5	3.5	3.5	4.4	040B0029

¹⁾ 1/4 in. flare connection to oil return line.

²⁾ 6 mm ODF solder connection to oil return line.

Design / Function

1. Float
2. Oil container
3. Float needle
7. Orifice
8. Return oil connection
(1/4 in. / 6 mm flare / solder)
10. Connection nipple
12. Inlet connection
refrigerant vapour
13. Outlet connection
refrigerant vapour
15. Oil concentrator
17. Fixing strap

OUB 1/OUB 4

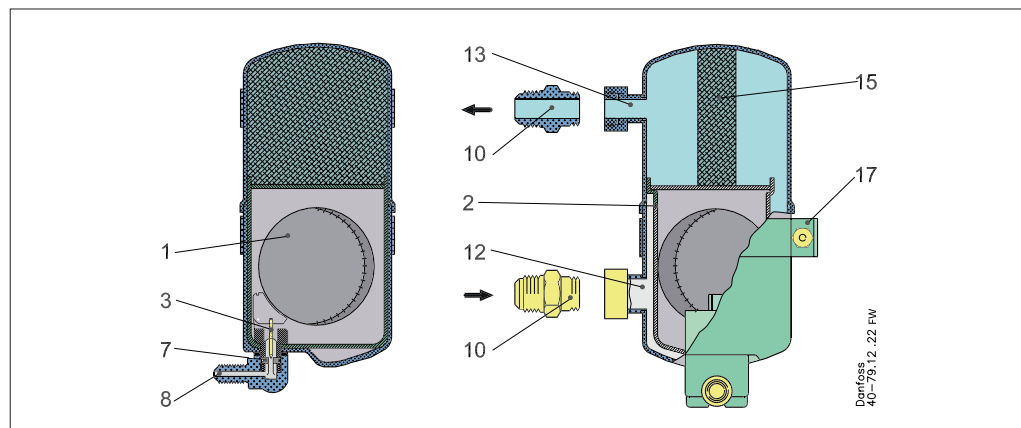

The very effective function of the OUB is due to the interaction of the following:

- velocity and change of flow direction of the incoming mixture of oil and refrigerant
- oil concentration, separation, and filtration
- storage of separated oil at high temperatures, thus preventing absorption of the refrigerant.

Refrigerant vapour is led through the inlet connection (12). The oil contained in the vapour is separated as a result of the change in velocity and direction through the oil concentrator (15) which at the same time also acts as an oil filter.

When the superheated refrigerant vapour flows around the oil container (2) some of the superheat is given off. In this way the oil container reaches a constant high temperature and the separated oil is stored in a warm state, i.e. with as low a refrigerant content as possible. Thus, the refrigerant is prevented from flowing to the crankcase where it could cause violent boiling.

The float (1) opens the needle valve (3) depending on the amount of oil, whereupon the condensing pressure forces the oil back to the crankcase therefore ensuring automatic oil return.

Data sheet | Oil separator, type OUB

Dimensions [mm]
and weights [kg]

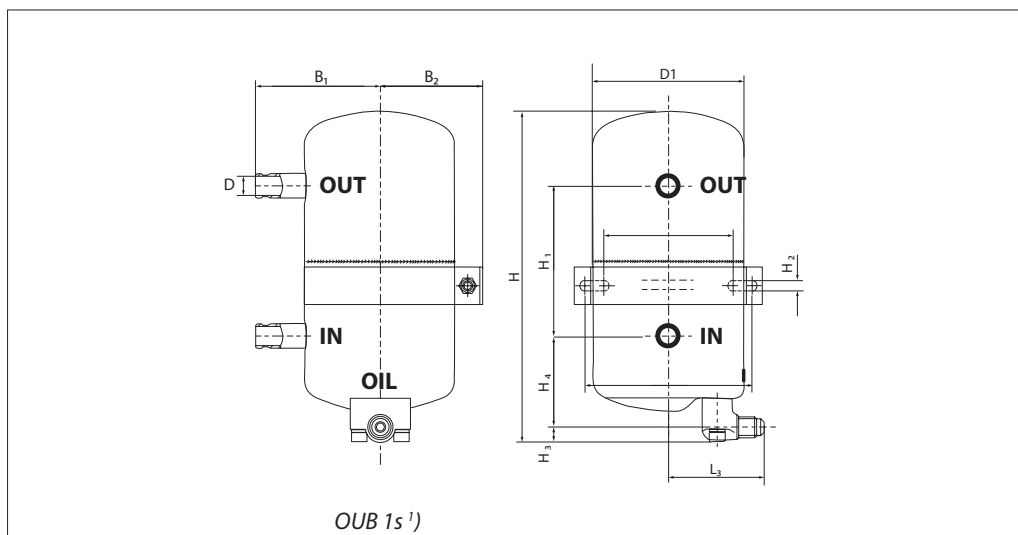
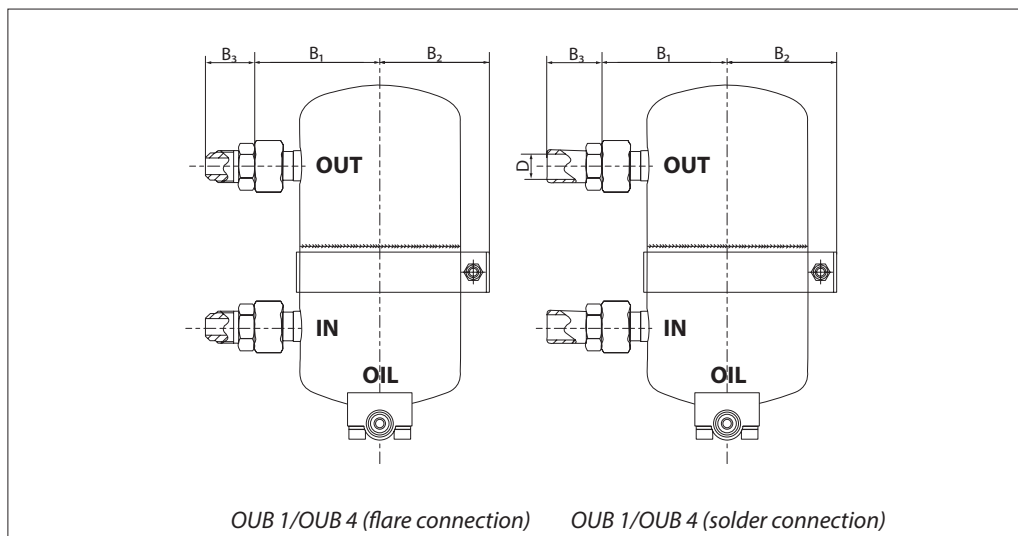
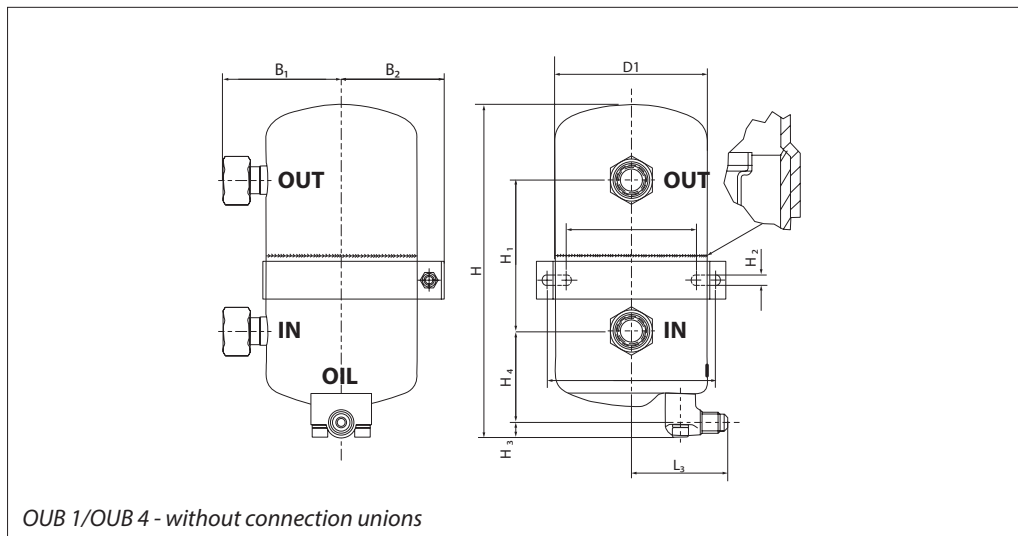

¹⁾ 1/4 in. flare connection to oil return line.

**Dimensions [mm]
and weights [kg]**
(continued)

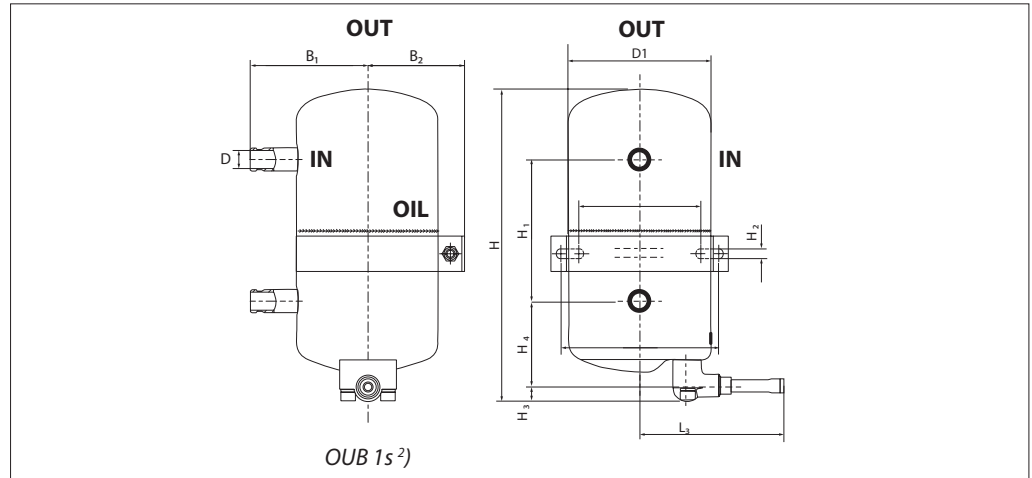

²⁾ 6 mm ODF solder connection to oil return line.

Type	Flare connection		H	H ₁	H ₂	H ₃	H ₄	L ₁	L ₂	L ₃	B ₁	B ₂	B ₃	øD ₁	Net weight
	[in]	[mm]													
OUB 1	3/8	10	177	80	5.5	9	49	69	89	50	60	55	30	81	1.2
	1/2	12	177	80	5.5	9	49	69	89	50	60	55	31	81	1.3
	5/8	16	177	80	5.5	9	49	69	89	50	60	55	38	81	1.4
OUB 4	5/8	16	263	126	8.5	9	67	111	143	72	94	85	44	131	4.6
	3/4	18	263	126	8.5	9	67	111	143	72	94	85	49	131	4.7
	1	25	263	126	8.5	9	67	111	143	72	94	85	51	131	4.8

Type	Solder connection		H	H ₁	H ₂	H ₃	H ₄	L ₁	L ₂	L ₃	B ₁	B ₂	B ₃	øD ₁	øD	Net weight
	[in]	[mm]														
OUB 1	3/8	10	177	80	5.5	9	49	69	89	50	60	55	29	81	9.6	1.2
	1/2	12	177	80	5.5	9	49	69	89	50	60	55	31	81	12.8	1.2
	5/8	16	177	80	5.5	9	49	69	89	50	60	55	42	81	16.0	1.3
OUB 1s	—	10	177	80	5.5	9	49	69	89	81	65	55	—	81	10.0	1.2
	—	10	177	80	5.5	9	49	69	89	50	65	55	—	81	10.0	1.2
OUB 4	5/8	16	263	126	8.5	9	67	111	143	72	94	85	40	131	16.0	4.3
	3/4	18	263	126	8.5	9	67	111	143	72	94	85	45	131	19.1	4.3
	7/8	22	263	126	8.5	9	67	111	143	72	94	85	45	131	22.3	4.3
	1	25	263	126	8.5	9	67	111	143	72	94	85	45	131	25.5	4.3
	1 1/8	28	263	126	8.5	9	67	111	143	72	94	85	47	131	28.7	4.3

Danfoss can accept no responsibility for possible errors in catalogues, brochures and other printed material. Danfoss reserves the right to alter its products without notice. This also applies to products already on order provided that such alterations can be made without consequential changes being necessary in specifications already agreed. All trademarks in this material are property of the respective companies. Danfoss and the Danfoss logotype are trademarks of Danfoss A/S. All rights reserved.