

DISCHARGE LINE MUFFLERS

The function of a Discharge Line Muffler is to reduce noise in the discharge line of a refrigeration or air-conditioning system

Applications

The muffler is designed to be installed directly after the compressor. The product range is designed for use with HCFC and HFC refrigerants, along with their associated oils.

How it works

The muffler reduces noise, due to gas pulsations, by allowing the gas to expand inside muffler chambers. Mufflers have internal baffles which are designed to dampen and smooth out low and high frequency compressor gas sound waves.

Main Features

- Robust design
- Bi-directional flow

Technical Specification

Allowable operating pressure = 0 to 31 barg

Allowable operating temperature = 0°C to + 121°C



Materials of Construction

The main body and internal baffles are made from carbon steel.

The connections are made from plated carbon steel.

Part No	Drawing reference	ODS (inch)	Dimensions (mm)			Weight (kg)	CE Cat
			Ø A	B	C		
S-6304	fig.1	1/2	76	197	19	1.2	SEP
S-6305	fig.1	5/8	76	197	19	1.2	SEP
S-6307	fig.1	7/8	76	246	11	1.4	SEP
S-6311	fig.1	1 1/8	76	246	11	1.5	SEP
S-6405	fig.2	5/8	102	171	24	1.9	SEP
S-6407	fig.2	7/8	102	178	24	1.9	SEP
S-6411	fig.1	1 1/8	102	322	24	2.9	Cat I
S-6413	fig.1	1 3/8	102	349	24	2.9	Cat I
S-6415	fig.1	1 5/8	102	464	19	3.8	Cat I
S-6621	fig.1	2 1/8	152	533	32	8.8	Cat II
S-6625	fig.1	2 5/8	152	533	25	8.8	Cat II
S-6631	fig.1	3 1/8	152	568	19	9.5	Cat II

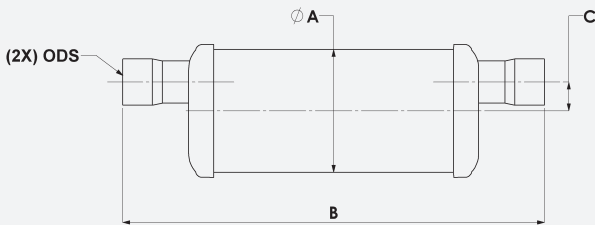

Fig. 1

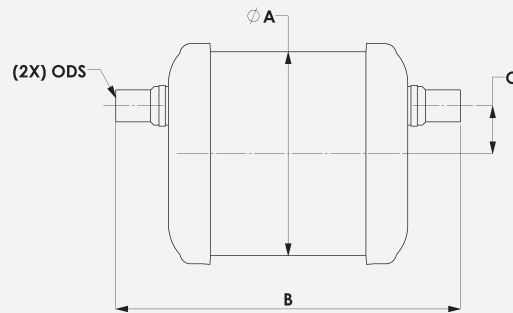

Fig. 2

DISCHARGE LINE MUFFLER

DISCHARGE LINE MUFFLERS

Selection Guidelines

Select a muffler with a connection size that matches or exceeds the discharge line size. Larger mufflers will tend to remove more pulsations due to the larger internal volume.

Installation – main issues

1. Install the muffler as close as possible to the compressor and before the oil separator.
2. When mounted in a horizontal or angled position, the side with the label must be top centre to help prevent oil collection inside the muffler. Oil inside the muffler will reduce the performance along with causing a loss of oil in the compressor crankcase. Positioning the muffler at a slight angle so that the outlet port is below the inlet will also help prevent oil collection. Mufflers that are mounted vertically will not collect oil.
3. A vibration eliminator should be installed between the compressor and the muffler to prevent transmitted vibration. The muffler should be supported at each side to prevent discharge pipe vibration, due to the weight of the muffler.
4. Mufflers will only remove noise due to discharge gas pulsations. If the noise is due to vibration, vibration eliminators should be added to the discharge line and possibly the suction line.
5. A single muffler may be installed on a common discharge line. However, some customers prefer to install one muffler per compressor on parallel racks.

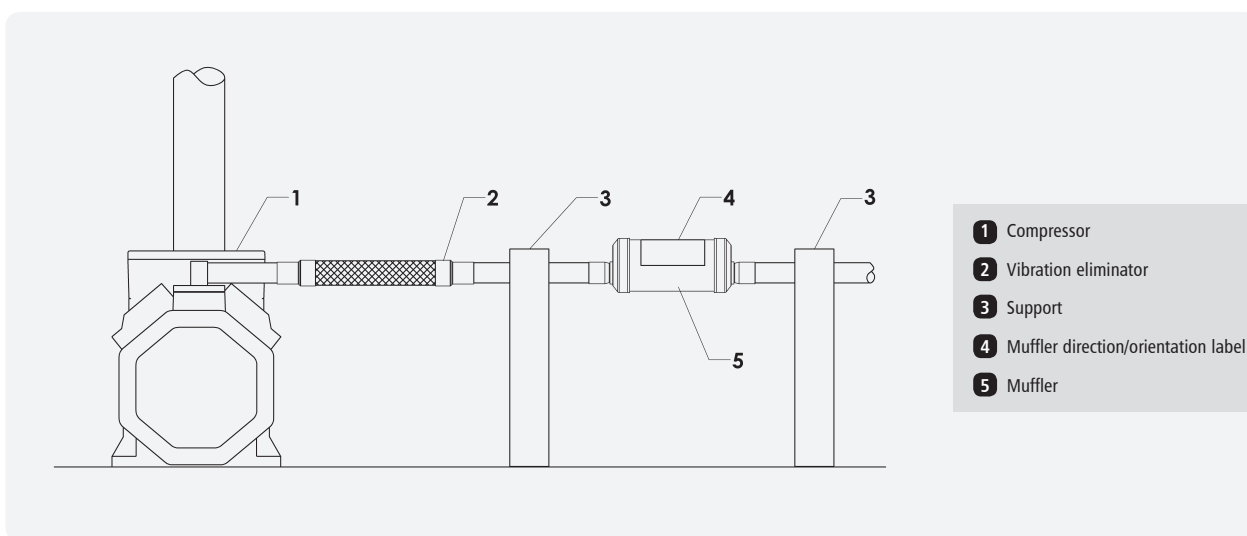

CORRECT MUFFLER SUPPORT