

## Data Sheet

Stop/Check valve & Check valve  
Type **SCA-X** and **CHV-X**

Designed to open at very low differential pressures, allow favourable flow conditions and are easy to disassemble for inspection and service



SCA-X are check valves with a built-in shut-off valve function. SCA-X valves are available in angleway versions.

CHV-X are check valves only. CHV-X are available in both angleway and straightway versions.

The valves are designed to open at very low differential pressures, allow favourable flow conditions and are easy to disassemble for inspection and service.

The SCA-X is equipped with vented cap and has internal backseating enabling the spindle seal to be replaced whilst the valve still under pressure.

Laser cut V-ports provide excellent opening characteristics (SCA-X/CHV-X 50-125).

The valve cone has a built-in flexibility to ensure a precise and tight closing towards the valve seat. A well balanced dampening effect between the piston and the cylinder gives an optimal protection during low loads and against pulsations.

## Features

- Modular Concept:
  - Each valve housing is available with several different connection types and sizes
  - Possible to convert SCA-X or CHV-X to any other product in the Flexline™ SVL family (Hand operated regulating valve, shut-off valve or strainer) just by replacing the complete top part
- Fast and easy valve overhaul service. It is easy to replace the top part and no welding is needed
- Designed to open at a very low differential pressure of 0.04 bar (0.58 psig)
- Designed with a built-in damping chamber preventing valve flutter in case of low refrigerant velocity and/or low density
- Each valve is clearly marked with type, size and performance range. Additional ID ring to be installed when preparing for Ammonia Heat Pump or Propylene application
- Easy to disassemble for inspection and service
- Internal backseating enables replacement of the spindle seal whilst the valve is active, i.e. under pressure
- Optimal flow characteristics ensuring quick opening to the fully open position
- Protection against pulsation by built-in damping facility
- Housing and bonnet material is low temperature steel according to requirements of the Pressure Equipment Directive and other international classification authorities
- Equipped with Stainless steel bolts
- Classification: DNV, CRN, BV, EAC etc. To get an updated list of certification on the products please contact your local Danfoss Sales Company



## Media

### **Refrigerants**

Applicable to HCFC, HFC, R717 (Ammonia), R744 (CO<sub>2</sub>), Propane, Butane, Iso-Butane and Ethane.

R717 Heat Pump and Propylene applications with replaced O-ring.

### **New refrigerants**

Danfoss products are continually evaluated for use with new refrigerants depending on market requirements.

When a refrigerant is approved for use by Danfoss, it is added to the relevant portfolio, and the R number of the refrigerant (e.g. R513A) will be added to the technical data of the code number. Therefore, products for specific refrigerants are best checked at [store.danfoss.com/en/](https://store.danfoss.com/en/), or by contacting your local Danfoss representative.

**Product specification**

**Pressure and temperature data**

Table 1: Pressure and temperature data

Features	Description
Temperature range	-60 °C /+150 °C (-76 °F/+302 °F).
Max. working pressure	52 bar (754 psi)

**Design**

**Housing**

The housing is made from special, cold resistant steel.

**Valve cone**

Valve cone with built in metallic stop - prevents damage to teflon ring in case of overtightening.

**Damping chamber**

The chamber is filled with refrigerants (gas or liquid), which provides a damping effect when the valve opens and closes.

**Spindle (SCA-X)**

Made of polished stainless steel, which is ideal for O-ring sealing.

**Packing Gland (SCA-X)**

The “full temperature range” packing gland is the standard for the entire SVL platform.

This ensures perfect tightness throughout the whole temperature range: -60/+150 °C (-76/+302 °F).

**Installation**

Figure 2: Example of marking ring, CHV-X

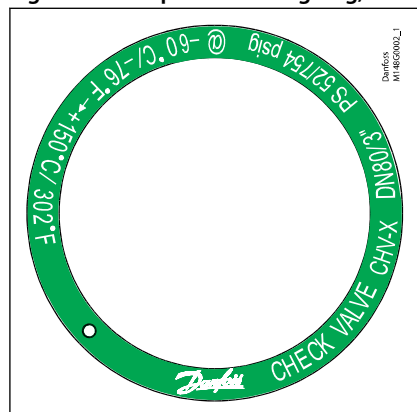

The valve must be mounted vertically with the cone downwards.

The valve is designed to resist very high internal pressure. However, the piping system in general should be designed to avoid liquid traps and reduce the risk of hydraulic pressure caused by thermal expansion.

For further information refer to installation guide for SCA-X/CHV-X.

If cold refrigeration oil having low viscosity enters and settles in the damping chamber, problems with the check valve may arise. Consequently, it may be necessary to modify the valve for more viscous liquids by enlarging the hole to the damping chamber.

## Material specification

### SCA-X 15 - 40, CHV-X 15 - 40 and CHV-X 15 - 40

Table 2: SCA-X 15 - 40 and CHV-X 15 - 40

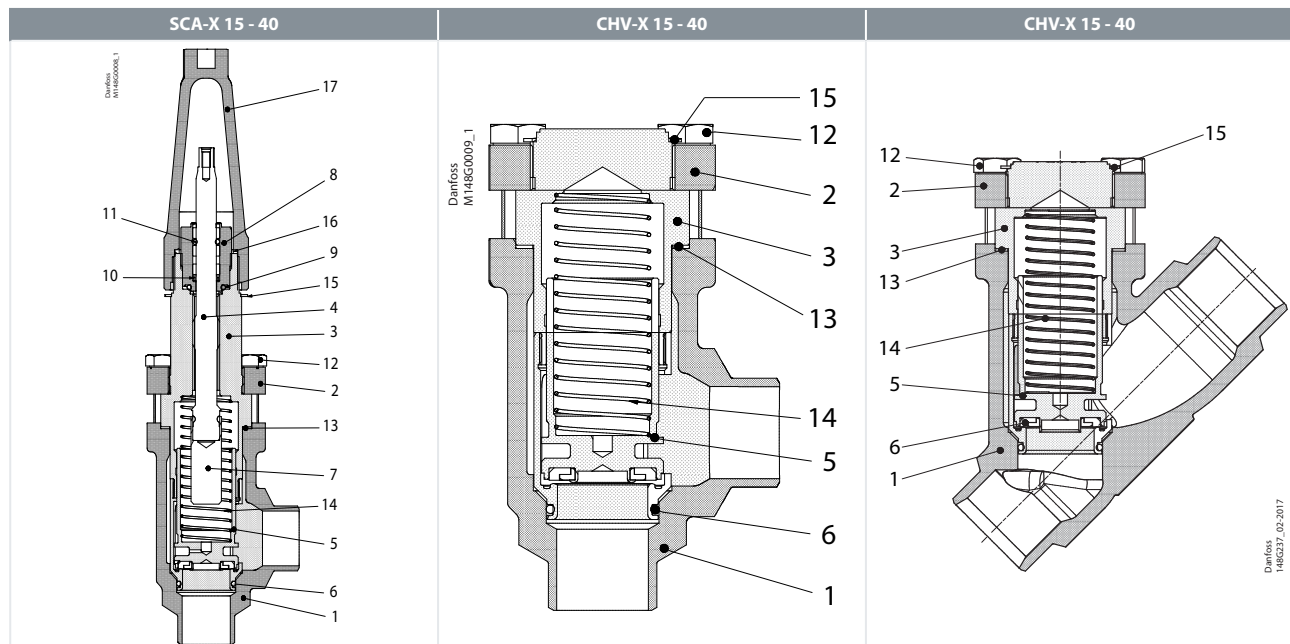
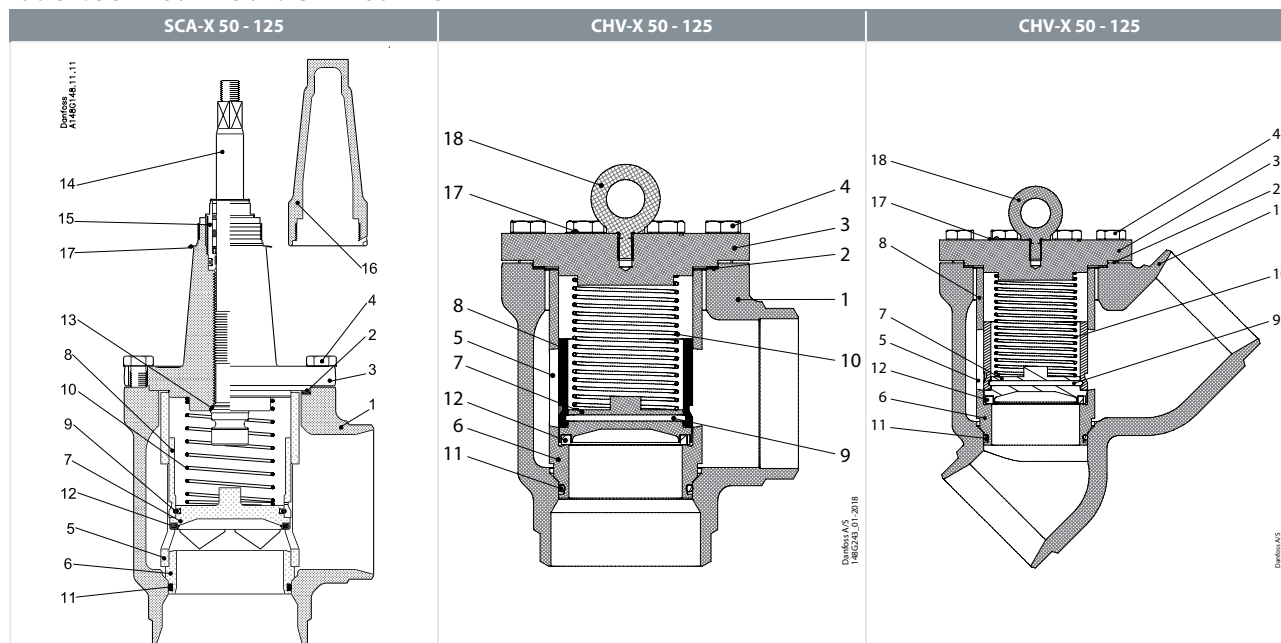

Table 3: Material specification

No.	Part	Material	DIN/EN	ISO	ASTM
1	Housing	Steel	P285QH EN10222-4		LF2, A350
2	Bonnet, Flange	Steel	P275NL1 EN10028-3		
3	Bonnet, Insert	Steel			
4	Spindle	Stainless steel	X 10CrNiS18-9	Type 17, 17440	AISI 303, 683/13
5	Cone	Steel Teflon (PTFE)			
6	O-ring	Chloroprene (Neoprene)			
7	Spindle extension	Steel			
8	Packing gland O-rings	Stainless steel Chloroprene (Neoprene)			
9	Packing washer	Aluminium			
10	Spring loaded seal	Teflon (PTFE)			
11	O-ring	Chloroprene (Neoprene)			
12	Bolts	Stainless steel	A2-70	A2-70	Type 308
13	Gasket	Fiber, non-asbestos			
14	Spring	Steel			
15	Identification ring	Stainless steel			
16	Seal cap gasket	Nylon			
17	Spindle seal cap	Aluminium			

SCA-X 50 - 125 and CHV-X 50 - 125

Table 4: SCA-X 50 - 125 and CHV-X 50 - 125



No.	Part	Material	DIN/EN	ISO	ASTM
1	Housing DN 50-65	Steel	P285 QH EN 10222-4		LF2, A350
			G20Mn5 QT SEW 685		LCC, A352
	Housing DN 80-125	Steel	G20Mn5 QT SEW 685		LCC, A352
2	Gasket	Fiber, Non-asbestos			
3	SCA-X: Valve bonnet CHV-X: End cover	Steel	P285 QH EN 10222-4		LF2, A350
4	Bolts	Stainless steel	A2-70	A2-70	A-276
5	Tube	Steel			
6	Seat	Steel			
7	Valve plate	Steel			
8	Guide sleeve	Steel			
9	Spring ring	Steel			
10	Spring	Steel			
11	O-ring	Chloroprene (Neoprene)			
12	Teflon ring	Teflon (PTFE)			
13	Soft back seal	Teflon (PTFE)			
14	Spindle DN 50-65	Stainless steel	X8CrNiS18-9 17440	Type 17 R 683/13	AISI 303
	Spindle DN 80-125	Stainless steel	X5CrNi1810 17440	Type 11 683/13	AISI 304 A-276
15	Packing gland	Stainless steel	9Mn28, 1651	Type 2 R 683/9	1213, SAE J403
16	Spindle seal cap and gasket	Aluminium			
17	Marking label	Stainless steel			
18	Eye bolt DIN 580	Steel			

**Computation and selection**

**Introduction**

When dimensioning SCA-X/CHV-X, it is important to select a valve that is best suited to all operating conditions. Therefore, it is necessary to consider both the nominal and part load working conditions.

Please refer to **Coolselector®2** for calculation and selection of the right SCA-X/CHV-X.

## Connections

### Available with the following connections:

- Butt-weld DIN (EN 10220)
  - DN 15 - 125 (½ - 5 in.)
- Butt-weld ANSI (B 36.10 Schedule 80),
  - DN 15 - 40 (½ - 1½ in.)
- Butt-weld ANSI (B 36.10 Schedule 40),
  - DN 50 - 125 (2 - 5 in.)
- Butt-weld GOST, (8734-75 and 8732-78)
  - DN 15 - 125 (½ - 5 in.)
- Socket-weld ANSI (B 16.11),
  - DN 50 (2 in.)

Figure 3: DIN

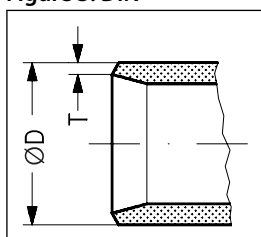

Table 5: Butt-weld DIN (EN 10220)

Size		ØD	T	ØD	T	k <sub>v</sub> Angleway	C <sub>v</sub> Angleway	k <sub>v</sub> Straightway	C <sub>v</sub> Straightway
mm	in.	mm	mm	in.	in.	m <sup>3</sup> /h	US <sub>gal</sub> /min	m <sup>3</sup> /h	US <sub>gal</sub> /min
15	½	21.3	2.3	0.839	0.091	8	9.3	4	4.6
20	¾	26.9	2.3	1.059	0.091	10	11.6	7	8.1
25	1	33.7	2.6	1.327	0.102	24	27.8	16	18.6
32	1¼	42.4	2.6	1.669	0.102	30	34.8	21	24.4
40	1½	48.3	2.6	1.902	0.102	30	34.8	21	24.4
50	2	60.3	2.9	2.37	0.11	45	53	28	34
65	2½	76.1	2.9	3.00	0.11	72	85	41	48
80	3	88.9	3.2	3.50	0.13	103	129	81	94
100	4	114.3	3.6	4.50	0.14	196	232	157	182
125	5	139.7	4.0	5.50	0.16	301	356	250	290

Figure 4: ANSI

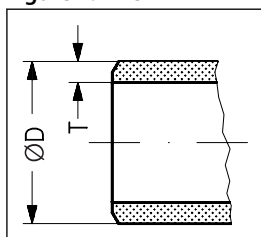

Table 6: Butt-weld ANSI (B 36.10 Schedule 80)

Size		ØD	T	ØD	T	k <sub>v</sub> Angleway	C <sub>v</sub> Angleway	k <sub>v</sub> Straightway	C <sub>v</sub> Straightway
mm	in.	mm	mm	in.	in.	m <sup>3</sup> /h	US <sub>gal</sub> /min	m <sup>3</sup> /h	US <sub>gal</sub> /min
15	½	21.3	3.7	0.839	0.146	8	9.3	4	4.6
20	¾	26.9	4.0	1.059	0.158	10	11.6	7	8.1
25	1	33.7	4.6	1.327	0.181	24	27.8	16	18.6
32	1¼	42.4	4.9	1.669	0.193	30	34.8	21	24.4
40	1½	48.3	5.1	1.902	0.201	30	34.8	21	24.4



## Stop/Check valve & and Check valve, type SCA-X and CHV-X

**Table 7: Butt-weld ANSI (B 36.10 Schedule 40)**

Size		ØD	T	ØD	T	k <sub>v</sub> Angleway	C <sub>v</sub> Angleway	k <sub>v</sub> Straight-way	C <sub>v</sub> Straight-way
mm	in.	mm	mm	in.	in.	m <sup>3</sup> /h	US <sub>gal/min</sub>	m <sup>3</sup> /h	US <sub>gal/min</sub>
50	2	60.3	3.9	2.37	0.15	45	53	28	34
65	2½	76.1	5.2	2.87	0.20	72	85	41	48
80	3	88.9	5.5	3.50	0.22	103	129	81	94
100	4	114.3	6.0	4.50	0.24	196	232	157	182
125	5	141.3	6.6	5.56	0.26	301	356	250	290

**Figure 5: GOST**

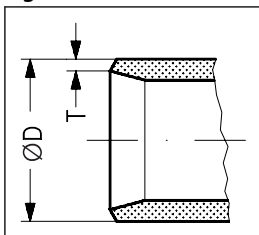

**Table 8: Butt-weld GOST (8734-75 and 8732-78)**

Size		ØD	T	ØD	T	k <sub>v</sub> Angleway	C <sub>v</sub> Angleway	k <sub>v</sub> Straight-way	C <sub>v</sub> Straight-way
mm	in.	mm	mm	in.	in.	m <sup>3</sup> /h	US <sub>gal/min</sub>	m <sup>3</sup> /h	US <sub>gal/min</sub>
15	½	18	2	0.709	0.079	8	9.3	4	4.6
20	¾	25	2.5	0.984	0.098	10	11.6	7	8.1
25	1	32	3	1.260	0.118	24	28.8	16	18.6
32	1¼	38	3	1.496	0.118	30	49.4	21	24.4
40	1½	45	3	1.772	0.118	30	52.4	21	24.4
50	2	57	3.5	2.244	0.138	45	53	28	34
65	2½	76.1	2.9	3	0.11	72	85	41	48
80	3	88.9	3.2	3.50	0.13	103	129	81	94
100	4	108	4	4.252	0.157	196	232	157	182
125	5	133	4	5.236	0.157	301	356	250	290

**Figure 6: SOC**

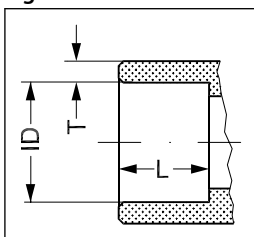

**Table 9: Socket welding ANSI (B 16.11)**

Size		ID	T	ID	T	L	L
mm	in.	mm	mm	in.	in.	mm	in.
15	½	21.8	6	0.858	0.235	10	0.39
20	¾	27.2	4.6	1.071	0.181	13	0.51
25	1	33.9	7.2	1.335	0.284	13	0.51
32	1¼	42.7	6.1	1.743	0.240	13	0.51
40	1½	48.8	6.6	1.921	0.260	13	0.51
50	2	61.2	6.2	2.41	0.24	16	0.63

## Dimensions and weights

### SCA-X/CHV-X 15-40 (½-1½ in.)

Table 10: SCA-X /CHV-X 15-40 (½-1½ in.)

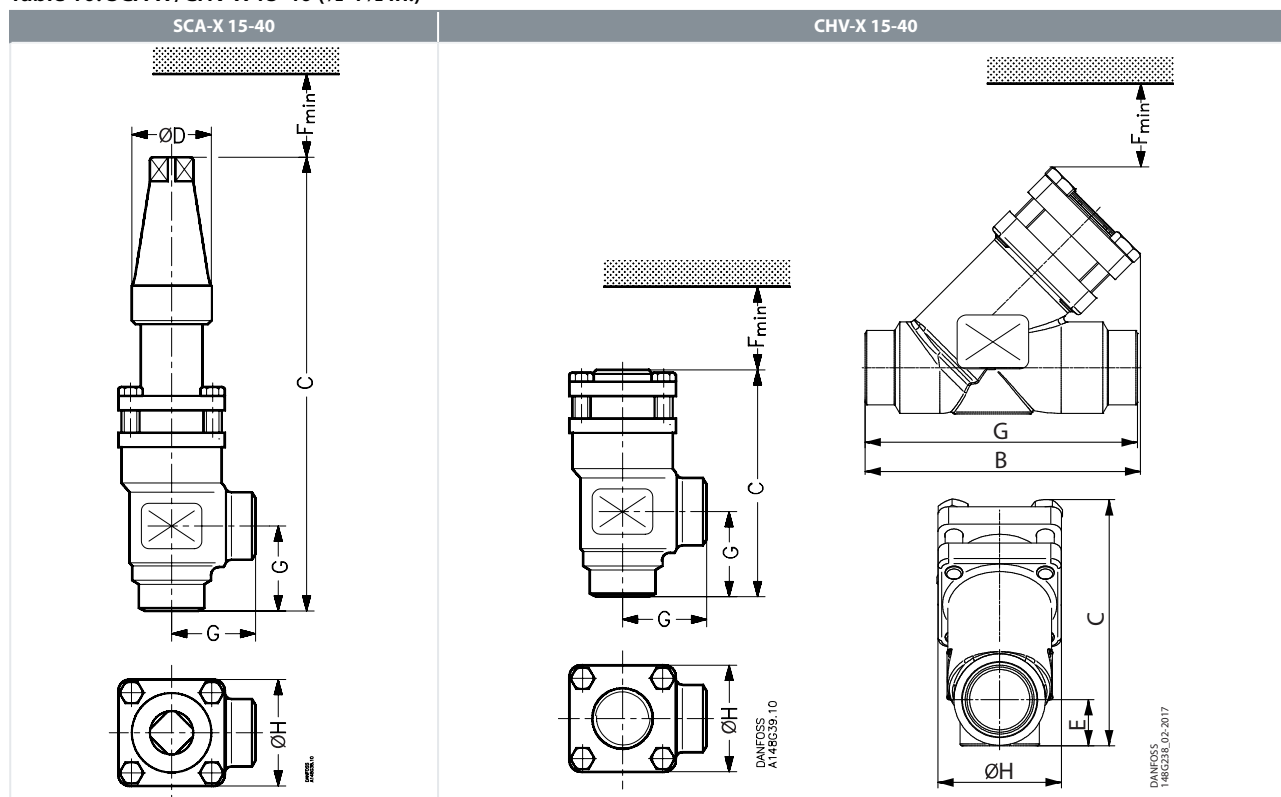

Table 11: SCA-X 15-40

Valve size	C		G		ØD		F <sub>min</sub>		ØH		Weight	
	mm	in.	mm	in.	mm	in.	mm	in.	mm	in.	kg	lb
SCA-X 15 (½ in.)	212	8.35	45	1.77	38	1.50	60	2.36	60	2.36	1.6	3.53
SCA-X 20 (¾ in.)	212	8.35	45	1.77	38	1.50	60	2.36	60	2.36	1.6	3.53
SCA-X 25 (1 in.)	295	11.61	55	2.17	50	1.97	85	3.35	70	2.76	3.2	7.05
SCA-X 32 (1¼ in.)	295	11.61	55	2.17	50	1.97	85	3.35	70	2.76	3.2	7.05
SCA-X 40 (1½ in.)	295	11.61	55	2.17	50	1.97	85	3.35	70	2.76	3.2	7.05

Table 12: CHV-X 15-40 Angleway

Valve size	C		G		F <sub>min</sub>		ØH		Weight	
	mm	in.	mm	in.	mm	in.	mm	in.	kg	lb
CHV-X 15 (½ in.)	103	4.06	45	1.77	60	2.36	60	2.36	1.2	2.65
CHV-X 20 (¾ in.)	103	4.06	45	1.77	60	2.36	60	2.36	1.2	2.65
CHV-X 25 (1 in.)	143	5.63	55	2.17	85	3.35	70	2.76	2.3	5.07
CHV-X 32 (1¼ in.)	143	5.63	55	2.17	85	3.35	70	2.76	2.3	5.07
CHV-X 40 (1½ in.)	143	5.63	55	2.17	85	3.35	70	2.76	2.3	5.07

Table 13: CHV-X 15-40 Straightway

Valve size	C		B		E		G		F <sub>min</sub>		ØH		Weight	
	mm	in.	mm	in.	mm	in.	mm	in.	mm	in.	mm	in.	kg	lb
CHV-X 15 (½ in.)	99	3.90	114	4.49	19	0.75	120	4.72	60	2.36	60	2.36	1.3	2.87
CHV-X 20 (¾ in.)	99	3.90	114	4.49	19	0.75	120	4.72	60	2.36	60	2.36	1.3	2.87
CHV-X 25 (1 in.)	141	5.55	157	6.18	26	1.02	155	6.10	85	3.35	70	2.76	2.6	5.73
CHV-X 32 (1¼ in.)	141	5.55	157	6.18	26	1.02	155	6.10	85	3.35	70	2.76	2.6	5.73
CHV-X 40 (1½ in.)	141	5.55	157	6.18	26	1.02	155	6.10	85	3.35	70	2.76	2.6	5.73

## Stop/Check valve & and Check valve, type SCA-X and CHV-X

**Table 14: CHV-X 32-40 Straightway, Socket weld**

Valve size	C		B		E		G		F <sub>min</sub>		ØH		Weight	
	mm	in.	mm	in.	mm	in.	mm	in.	mm	in.	mm	in.	kg	lb
<b>CHV-X 32-40 (1¼-1½ in.)</b>	132	5.20	156	6.14	26	1.02	155	6.10	85	3.35	70	2.76	2.8	6.11

**NOTE:**

Specified weights are approximate values only.

### SCA-X/CHV-X 50-65 (2-2½ in.)

**Table 15: SCA-X/CHV-X 50-65 (½- 1½ in.)**

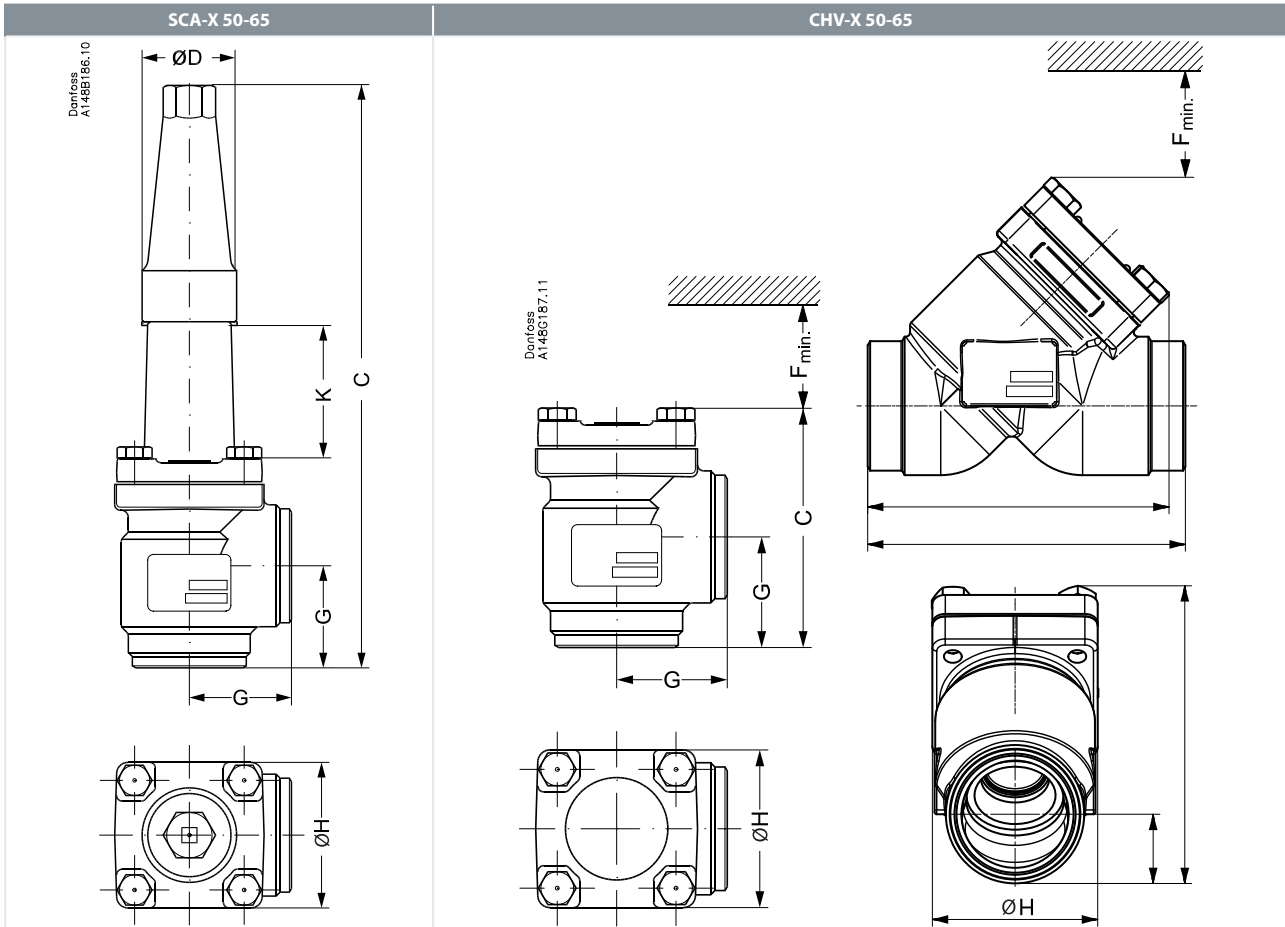

**Table 16: SCA-X**

Valve size	K		C		G		ØD		ØH		Weight	
	mm	in.	mm	in.	mm	in.	mm	in.	mm	in.	kg	lb
<b>SCA-X 50</b>	70	2.76	315	12.40	60	2.36	50	1.97	77	3.03	3.8	8.40
<b>SCA-X (2)</b>	70	2.76	315	12.40	60	2.36	50	1.97	77	3.03	3.8	8.40
<b>SCA-X 65</b>	70	2.76	335	13.19	70	2.76	50	1.97	90	3.54	5.5	12.16
<b>SCA-X (2½)</b>	70	2.76	335	13.19	70	2.76	50	1.97	90	3.54	5.5	12.16

**Table 17: CHV-X Angleway**

Valve size	C		G		F <sub>min</sub>		ØH		Weight	
	mm	in.	mm	in.	mm	in.	mm	in.	kg	lb
<b>CHV-X 50</b>	132	5.20	60	2.36	92	3.62	77	3.03	3.2	7.10
<b>CHV-X (2)</b>	132	5.20	60	2.36	92	3.62	77	3.03	3.2	7.10
<b>CHV-X 65</b>	152	5.98	70	2.76	107	4.21	90	3.54	4.5	9.95
<b>CHV-X (2½)</b>	152	5.98	70	2.76	107	4.21	90	3.54	4.5	9.95

## Stop/Check valve & and Check valve, type SCA-X and CHV-X

**Table 18: CHV-X Straightway**

Valve size	C		B		E		G		F <sub>min</sub>		ØH		Weight	
	mm	in.	mm	in.	mm	in.	mm	in.	mm	in.	mm	in.	kg	lb
<b>CHV-X 50</b>	139	5.47	140	5.51	32	1.26	148	5.83	92	3.62	77	3.03	3	6.72
<b>CHV-X (2)</b>	139	5.47	140	5.51	32	1.26	148	5.83	92	3.62	77	3.03	3	6.72
<b>CHV-X 65</b>	163	6.4	164	6.4	40	1.6	176	6.9	107	4.21	90	3.54	4.3	9.44
<b>CHV-X (2½)</b>	163	6.4	164	6.4	40	1.6	176	6.9	107	4.21	90	3.54	4.3	9.44

**Table 19: CHV-X Straightway, Socket weld**

Valve size	C		B		E		G		F <sub>min</sub>		ØH		Weight	
	mm	in.	mm	in.	mm	in.	mm	in.	mm	in.	mm	in.	kg	lb
<b>CHV-X 50</b>	142	5.59	147	5.79	37	1.46	162	6.38	92	3.62	77	3.03	3.8	8.33
<b>CHV-X (2)</b>	142	5.59	147	5.79	37	1.46	162	6.38	92	3.62	77	3.03	3.8	8.33

**NOTE:**

Specified weights are approximate values only.

**SCA-X/CHV-X 80-125 (3-5 in.)**

**Table 20: SCA-X/CHV-X 80-125 (2 - 2½ in.)**

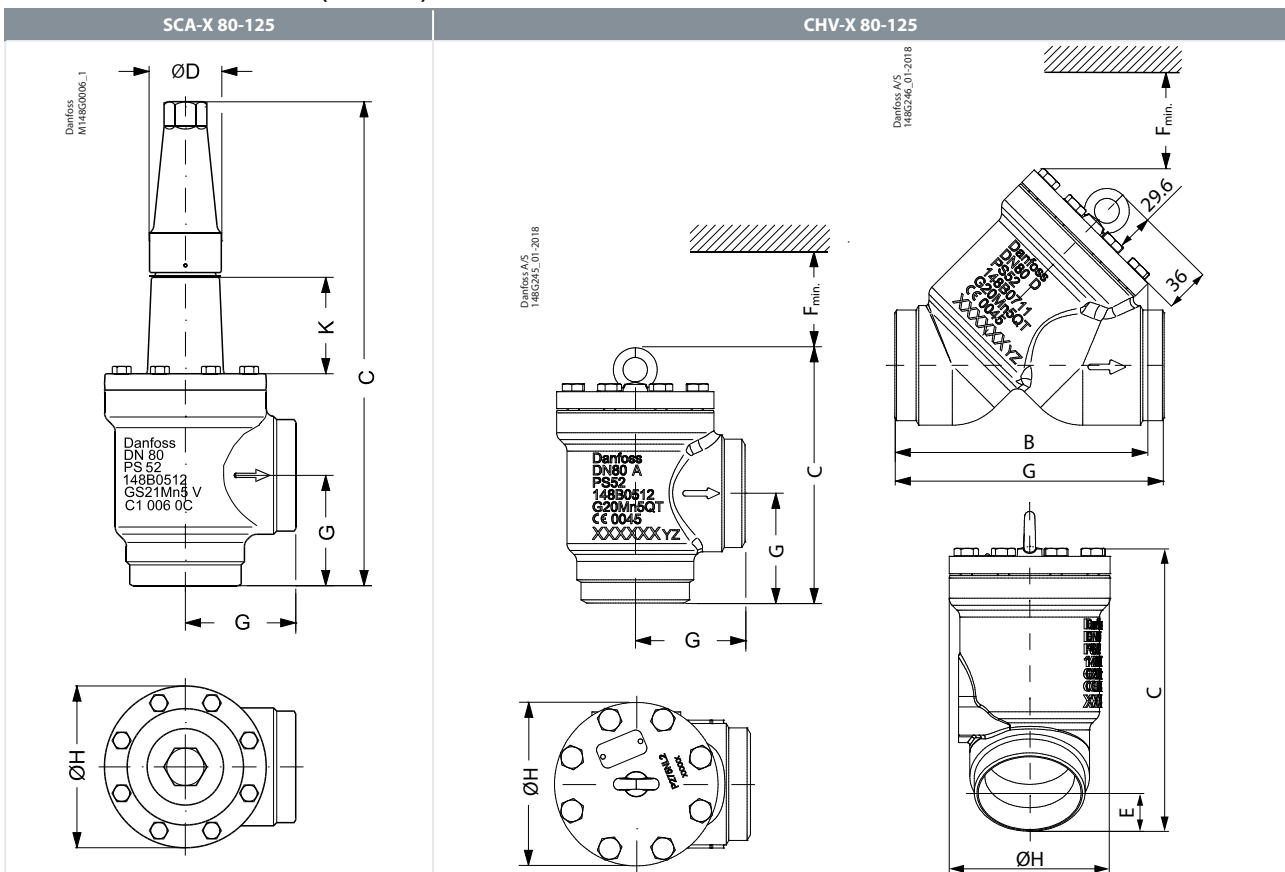

**Table 21: SCA-X**

Valve size	K		C		G		ØD		ØH		Weight	
	mm	in.	mm	in.	mm	in.	mm	in.	mm	in.	kg	lb
<b>SCA-X 80</b>	76	3.00	388	15.28	90	3.54	58	2.28	129	5.08	9.7	21.4
<b>SCA-X (3)</b>	76	3.00	388	15.28	90	3.54	58	2.28	129	5.08	9.7	21.4
<b>SCA-X 100</b>	90	3.54	437	17.20	106	4.17	58	2.28	156	6.14	15.3	33.7
<b>SCA-X (4)</b>	90	3.54	437	17.20	106	4.17	58	2.28	156	6.14	15.3	33.7
<b>SCA-X 125</b>	90	3.54	533	20.98	128	5.04	74	2.91	193	7.60	28.1	61.9
<b>SCA-X (5)</b>	90	3.54	533	20.98	128	5.04	74	2.91	193	7.60	28.1	61.9

## Stop/Check valve & and Check valve, type SCA-X and CHV-X

**Table 22: CHV-X Angleyway**

Valve size	C		G		F <sub>min</sub>		ØH		Weight	
	mm	in.	mm	in.	mm	in.	mm	in.	kg	lb
<b>CHV-X 80</b>	218.6	8.61	90	3.54	103.4	4.07	129	5.08	8.7	19.23
<b>CHV-X (3)</b>	218.6	8.61	90	3.54	103.4	4.07	129	5.08	8.7	19.23
<b>CHV-X 100</b>	252.6	9.94	106	4.17	133.4	5.25	156	6.14	14.3	31.60
<b>CHV-X (4)</b>	252.6	9.94	106	4.17	133.4	5.25	156	6.14	14.3	31.60
<b>CHV-X 125</b>	297.6	11.72	128	5.04	160.4	6.31	193	7.60	25.6	56.58
<b>CHV-X (5)</b>	297.6	11.72	128	5.04	160.4	6.31	193	7.60	25.6	56.58

**Table 23: CHV-X Straightway**

Valve size	C		B		E		G		F <sub>min</sub>		ØH		Weight	
	mm	in.	mm	in.	mm	in.	mm	in.	mm	in.	mm	in.	kg	lb
<b>CHV-X 80</b>	206	8.11	204	8.03	48	1.89	216	8.50	133	5.24	129	5.08	9.3	20.4
<b>CHV-X (3)</b>	206	8.11	204	8.03	48	1.89	216	8.50	133	5.24	129	5.08	9.3	20.4
<b>CHV-X 100</b>	256	10.08	248	9.76	62	2.44	264	10.39	163	6.43	156	6.14	14.6	32.29
<b>CHV-X (4)</b>	256	10.08	248	9.76	62	2.44	264	10.39	163	6.43	156	6.14	14.6	32.29
<b>CHV-X 125</b>	314	12.36	302	11.89	74	2.91	322	12.68	190	7.48	193	7.60	32.5	71.65
<b>CHV-X (5)</b>	314	12.36	302	11.89	74	2.91	322	12.68	190	7.48	193	7.60	32.5	71.65

**NOTE:**

Specified weights are approximate values only.

## Ordering

### Ordering complete valves

#### How to order

The table below is used to identify the valve required.

Please note that the type codes only serve to identify the valves, some of which may not form part of the standard product range.

For further information please contact your local Danfoss Sales Company.

Table 24: Ordering complete valves

Valve type	SCA-X CHV-X	Check & Stop valve				
		Check Valve				
			A	D	G	SOC
(valve size measured on the connection diameter)	15	DN 15	X	X	X	X
	20	DN 20	X	X	X	X
	25	DN 25	X	X	X	X
	32	DN 32	X	X	X	X
	40	DN 40	X	X	X	X
	50	DN 50	X	X	X	X
	65	DN 65	X	X		
	80	DN 80	X	X		
	100	DN 100	X	X	X	
	125	DN 125	X	X	X	
Connections	A D G SOC	Welding branches: ANSI B 31.5 schedule 80 DN 15 - 40 (½ - 1½ in.) Welding branches: ANSI B 31.5 schedule 40 DN 50 - 125 (2 - 5 in.) Welding branches: EN 10220 Butt-weld connection: GOST (8734-75 and 8732-78) Socket weld: ANSI B 16.11				
Valve housing	ANG STR	Angle flow Straight flow				

#### ❗ IMPORTANT:

Where products need to be certified according to specific certification societies the relevant information should be included at the time of order.

### Angleway

#### SCA-X

Table 25: SCA-X Butt-weld DIN (EN 10220)

Size		Type	Code No.
mm	in.		
15	½	SCA-X 15 D ANG	148B5208
20	¾	SCA-X 20 D ANG	148B5308
25	1	SCA-X 25 D ANG	148B5408
32	1¼	SCA-X 32 D ANG	148B5508
40	1½	SCA-X 40 D ANG	148B5608
50	2	SCA-X 50 D ANG	148B5702
65	2½	SCA-X 65 D ANG	148B5803
80	3	SCA-X 80 D ANG	148B5902
100	4	SCA-X 100 D ANG	148B6002
125	5	SCA-X 125 D ANG	148B6102

## Stop/Check valve & and Check valve, type SCA-X and CHV-X

**Table 26: SCA-X Butt-weld ANSI (B 36.10 Schedule 80)**

Size		Type	Code No.
mm	in.		
15	½	SCA-X 15 A ANG	148B5209
20	¾	SCA-X 20 A ANG	148B5309
25	1	SCA-X 25 A ANG	148B5409
32	1¼	SCA-X 32 A ANG	148B5509
40	1½	SCA-X 40 A ANG	148B5609

**Table 27: SCA-X Butt-weld ANSI (B 36.10 Schedule 40)**

Size		Type	Code No.
mm	in.		
50	2	SCA-X 50 A ANG	148B5703
65	2½	SCA-X 65 A ANG	148B5802
80	3	SCA-X 80 A ANG	148B5903
100	4	SCA-X 100 A ANG	148B6004
125	5	SCA-X 125 A ANG	148B6103

**Table 28: SCA-X Socket welding ANSI (B 16.11)**

Size		Type	Code No.
mm	in.		
50	2	SCA-X 50 SOC ANG	148B5704

**ANG = Angleway**

### CHV-X

**Table 29: CHV-X Butt-weld DIN (EN 10220)**

Size		Type	Code No.
mm	in.		
15	½	CHV-X 15 D ANG	148B5236
20	¾	CHV-X 20 D ANG	148B5336
25	1	CHV-X 25 D ANG	148B5436
32	1¼	CHV-X 32 D ANG	148B5536
40	1½	CHV-X 40 D ANG	148B5636
50	2	CHV-X 50 D ANG	148B5736
65	2½	CHV-X 65 D ANG	148B5838
80	3	CHV-X 80 D ANG	148B5936
100	4	CHV-X 100 D ANG	148B6036
125	5	CHV-X 125 D ANG	148B6136

**Table 30: CHV-X Butt-weld ANSI (B 36.10 Schedule 80)**

Size		Type	Code No.
mm	in.		
15	½	CHV-X 15 A ANG	148B5237
20	¾	CHV-X 20 A ANG	148B5337
25	1	CHV-X 25 A ANG	148B5437
32	1¼	CHV-X 32 A ANG	148B5537
40	1½	CHV-X 40 A ANG	148B5637

**Table 31: CHV-X Butt-weld ANSI (B 36.10 Schedule 40)**

Size		Type	Code No.
mm	in.		
50	2	CHV-X 50 A ANG	148B5737
65	2½	CHV-X 65 A ANG	148B5837
80	3	CHV-X 80 A ANG	148B5937
100	4	CHV-X 100 A ANG	148B6037
125	5	CHV-X 125 A ANG	148B6137

Table 32: CHV-X Socket welding ANSI (B 16.11)

Size		Type	Code No.
mm	in.		
32	1¼	CHV 32 SOC ANG	148B5539
50	2	CHV 50 SOC ANG	148B5740

## Straightway

### CHV-X

Table 33: CHV-X Butt-weld DIN (EN 10220)

Size		Type	Code No.
mm	in.		
15	½	CHV-X 15 D STR	148B6581
20	¾	CHV-X 20 D STR	148B6583
25	1	CHV-X 25 D STR	148B6585
32	1¼	CHV-X 32 D STR	148B6587
40	1½	CHV-X 40 D STR	148B6589
50	2	CHV-X 50 D STR	148B6591
65	2½	CHV-X 65 D STR	148B6593
80	3	CHV-X 80 D STR	148B6595
100	4	CHV-X 100 D STR	148B6597
125	5	CHV-X 125 D STR	148B6599

Table 34: CHV-X Butt-weld ANSI (B 36.10 Schedule 80)

Size		Type	Code No.
mm	in.		
15	½	CHV-X 15 A STR	148B6582
20	¾	CHV-X 20 A STR	148B6584
25	1	CHV-X 25 A STR	148B6586
32	1¼	CHV-X 32 A STR	148B6588
40	1½	CHV-X 40 A STR	148B6590

Table 35: CHV-X Butt-weld ANSI (B 36.10 Schedule 40)

Size		Type	Code No.
mm	in.		
50	2	CHV-X 50 A STR	148B6592
65	2½	CHV-X 65 A STR	148B6594
80	3	CHV-X 80 A STR	148B6596
100	4	CHV-X 100 A STR	148B6598
125	5	CHV-X 125 A STR	148B6600

Table 36: CHV-X Socket welding ANSI (B 16.11)

Size		Type	Code No.
mm	in.		
15	½	CHV-X 15 SOC STR	148B6601
20	¾	CHV-X 20 SOC STR	148B6602
25	1	CHV-X 25 SOC STR	148B6603
32	1¼	CHV-X 32 SOC STR	148B6604
40	1½	CHV-X 40 SOC STR	148B6605
50	2	CHV-X 50 SOC STR	148B6606

STR = Straightway

## Ordering SCA-X from the parts programme

Example (select from table 37 and 38)

Example



## Stop/Check valve & and Check valve, type SCA-X and CHV-X

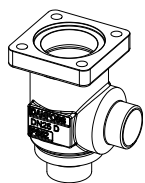

Valve housing, size 25 (1 in.),  
DIN butt weld, angleway,  
**148B5452**  
Table 37

+

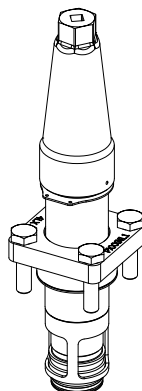

Top part, SCA-X  
size 25 (1 in.)  
**148B5482**  
Table 38

=

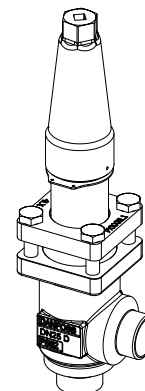

### Valve Housing SVL

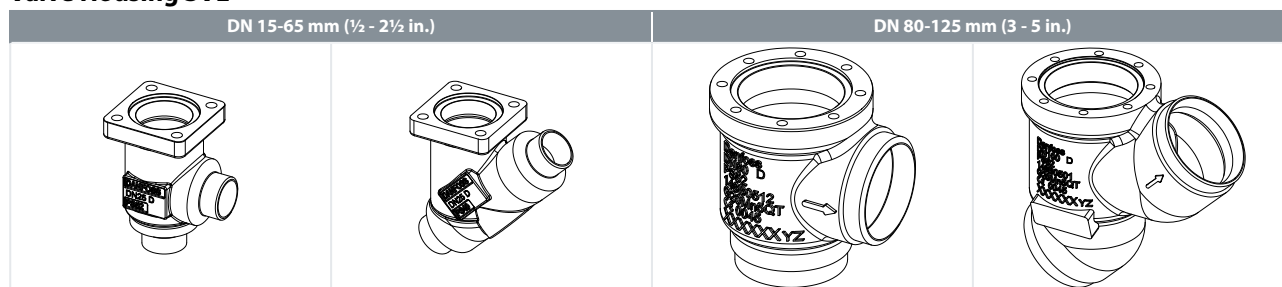
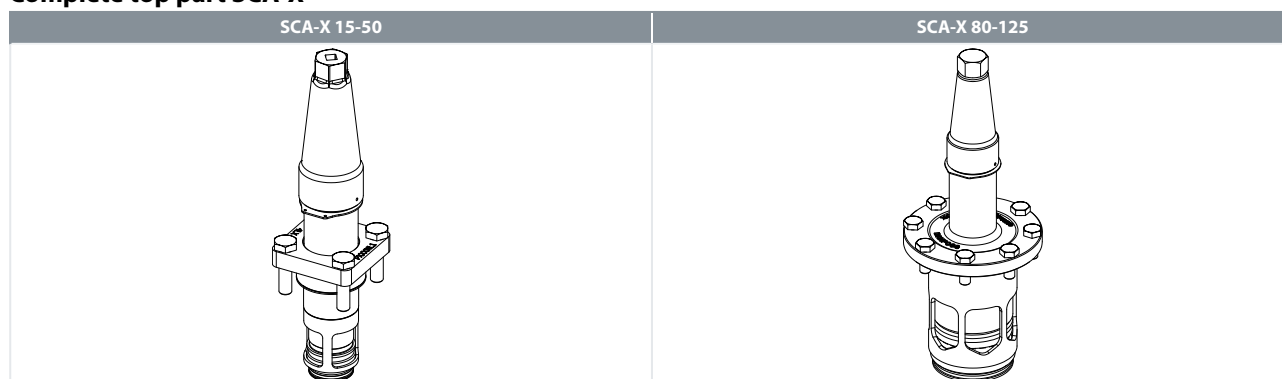

Table 37: SVL valve housings w/different connections

Sizes [DN]		Valve Housing SVL										
		DIN-Butt weld		ANSI-Butt weld		GOST-Butt-weld		SOC		FPT		T
[mm]	[in]	ANG	STR	ANG	STR	ANG	STR	ANG	STR	ANG	STR	ANG
15	½	148B5252	148B5253	148B5254	148B5255	148B5391	148B5392	148B5256	148B5257	148B5258	148B5259	–
20	¾	148B5352	148B5353	148B5354	148B5355	148B5393	148B5394	148B5356	148B5357	148B5358	148B5359	–
25	1	148B5452	148B5453	148B5454	148B5455	148B5498	148B5499	148B5456	148B5457	148B5458	148B5459	–
32	1¼	148B5576	148B5577	148B5578	148B5579	148B5593	148B5594	148B5580	148B5581	148B5582	148B5583	–
40	1½	148B5652	148B5653	148B5654	148B5655	148B5681	148B5682	148B5656	148B5657	–	–	–
50	2	148B5741	148B5742	148B5743	148B5744	148B5759	148B5760	148B5745	148B5746	–	–	–
65	2½	148B5816	148B5817	148B5818	148B5819	148B5816	148B5817	–	–	–	–	–
80	3	148B5912	148B5913	148B5914	148B5915	148B5912	148B5913	–	–	–	–	–
100	4	148B6014	148B6015	148B6016	148B6017	148B6033	148B6034	–	–	–	–	–
125	5	148B6112	148B6113	148B6114	148B6115	148B6133	148B6134	–	–	–	–	–

### Complete top part SCA-X



## Stop/Check valve & and Check valve, type SCA-X and CHV-X

Table 38: SCA-X complete top part including gaskets and bolts

Sizes [DN]		Complete top part
[mm]	[in]	
15	½	148B5282
20	¾	
25	1	
32	1¼	
40	1½	148B5482
50	2	
65	2½	148B5735
80	3	148B5825
100	4	148B5918
125	5	148B6019
		148B6118

### Ordering CHV-X from the parts programme

Example (select from table 40 and 41)

#### Example

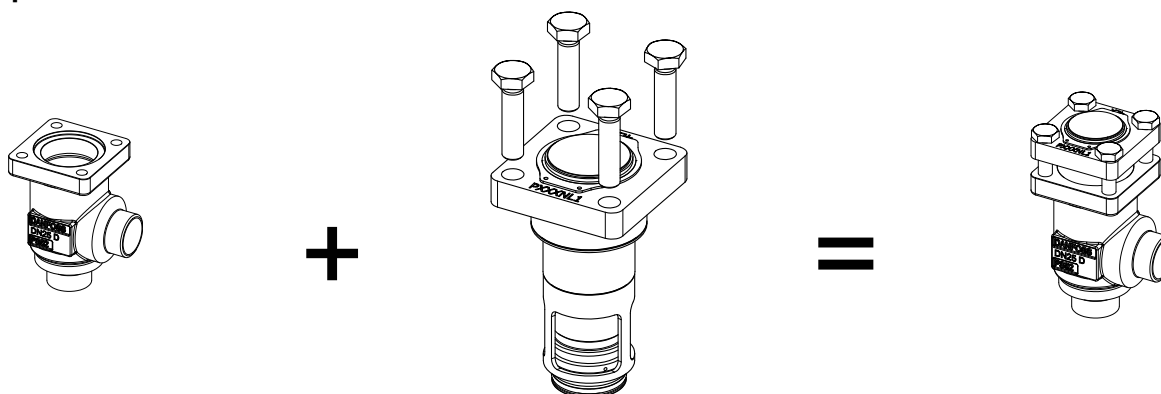

Valve housing, size 25 (1 in.),  
DIN butt weld, angleway,  
**148B5452**  
Table 40

Top part, CHV-X  
size 25 (1 in.)  
**148B5483**  
Table 41

### Valve Housing SVL

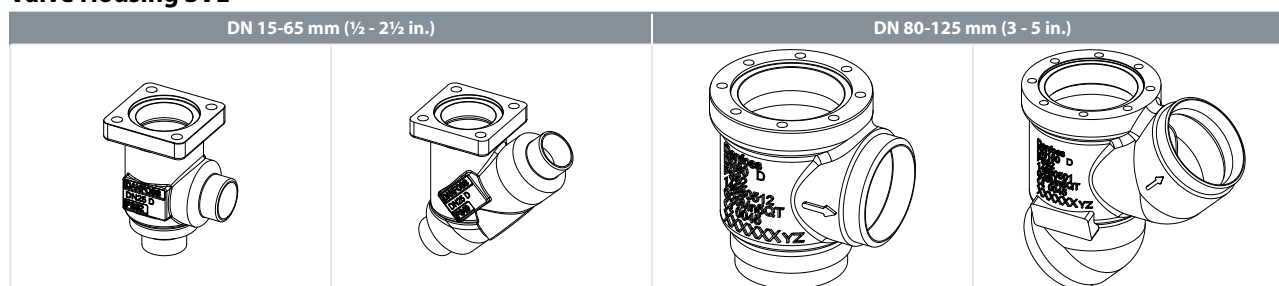

Table 39: SVL valve housings w/different connections

Sizes [DN]		Valve Housing SVL										
		DIN-Butt weld		ANSI-Butt weld		GOST-Butt-weld		SOC		FPT		T
[mm]	[in]	ANG	STR	ANG	STR	ANG	STR	ANG	STR	ANG	STR	ANG
15	½	148B5252	148B5253	148B5254	148B5255	148B5391	148B5392	148B5256	148B5257	148B5258	148B5259	–
20	¾	148B5352	148B5353	148B5354	148B5355	148B5393	148B5394	148B5356	148B5357	148B5358	148B5359	–
25	1	148B5452	148B5453	148B5454	148B5455	148B5498	148B5499	148B5456	148B5457	148B5458	148B5459	–
32	1¼	148B5576	148B5577	148B5578	148B5579	148B5593	148B5594	148B5580	148B5581	148B5582	148B5583	–
40	1½	148B5652	148B5653	148B5654	148B5655	148B5681	148B5682	148B5656	148B5657	–	–	–
50	2	148B5741	148B5742	148B5743	148B5744	148B5759	148B5760	148B5745	148B5746	–	–	–
65	2½	148B5816	148B5817	148B5818	148B5819	148B5816	148B5817	–	–	–	–	–

## Stop/Check valve & and Check valve, type SCA-X and CHV-X

Sizes [DN]		Valve Housing SVL										
		DIN-Butt weld		ANSI-Butt weld		GOST-Butt-weld		SOC		FPT		T
[mm]	[in]	ANG	STR	ANG	STR	ANG	STR	ANG	STR	ANG	STR	ANG
80	3	148B5912	148B5913	148B5914	148B5915	148B5912	148B5913	-	-	-	-	-
100	4	148B6014	148B6015	148B6016	148B6017	148B6033	148B6034	-	-	-	-	-
125	5	148B6112	148B6113	148B6114	148B6115	148B6133	148B6134	-	-	-	-	-

### Complete top part CHV-X

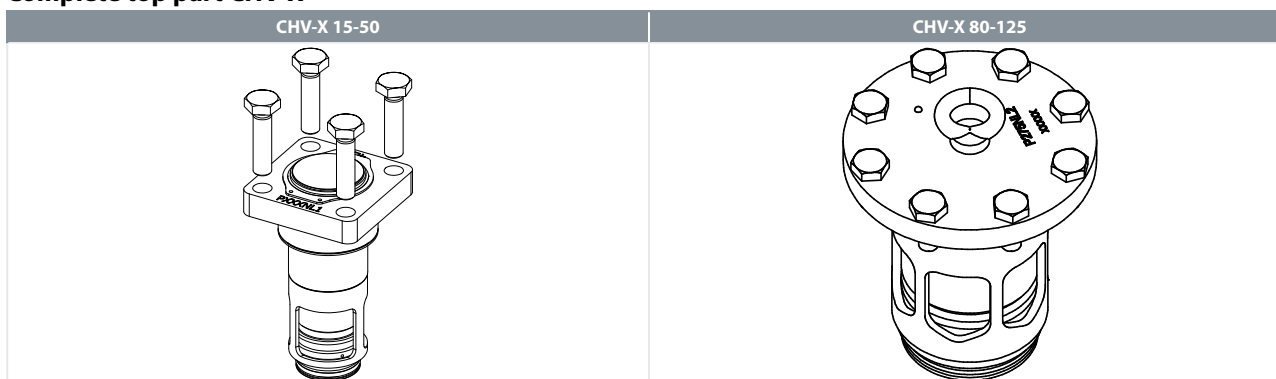

Table 40: CHV-X complete top part including gaskets and bolts

Sizes [DN]		Complete top part
[mm]	[in]	
15	½	148B5283
20	¾	
25	1	
32	1¼	148B5483
40	1½	
50	2	148B5747
65	2½	148B5827
80	3	148B5919
100	4	148B6022
125	5	148B6119

Table 41: Replacement kit (O-ring replacement) for R717 Ammonia Heat Pump\* and Propylene applications (including ID tag)

Size (DN)		O-ring kit for	
mm	in.	R717 Heat pump	R1270 Propylene
15	½	148B6070	148B6077
20	¾		
25	1		
32	1¼	148B6071	148B6078
40	1½		
50	2	148B6072	148B6079
65	2½	148B6073	148B6080
80	3	148B6074	148B6081
100	4	148B6075	148B6082
125	5	148B6076	148B6083

\*Replacement kits for R717 Ammonia Heat Pump is applicable for continuous operating temperature between +100 °C to 150 °C (212 °F to 302 °F)

## Certificates, declarations and approvals

The list contains all certificates, declarations, and approvals for this product type. Individual code number may have some or all of these approvals, and certain local approvals may not appear on the list.

Some approvals may change over time. You can check the most current status at [danfoss.com](http://danfoss.com) or contact your local Danfoss representative if you have any questions.

### **Pressure Equipment Directive (PED)**

REG valves are approved according to the European standard specified in the Pressure Equipment Directive and are CE marked.

**Table 42: Pressure Equipment Directive (PED)**

REG-SA and REG-SB valves		
Nominal bore	DN = < 25 mm (1 in.)	DN32 - 65 mm (1¼ - 2½ in.)
Classified for	Fluid group I	
Category	Article 3, paragraph 3	II

## Online support

Danfoss offers a wide range of support along with our products, including digital product information, software, mobile apps, and expert guidance. See the possibilities below.

### The Danfoss Product Store



The Danfoss Product Store is your one-stop shop for everything product related—no matter where you are in the world or what area of the cooling industry you work in. Get quick access to essential information like product specs, code numbers, technical documentation, certifications, accessories, and more.

Start browsing at [store.danfoss.com](https://store.danfoss.com).

### Find technical documentation



Find the technical documentation you need to get your project up and running. Get direct access to our official collection of data sheets, certificates and declarations, manuals and guides, 3D models and drawings, case stories, brochures, and much more.

Start searching now at [www.danfoss.com/en/service-and-support/documentation](https://www.danfoss.com/en/service-and-support/documentation).

### Get local information and support



Local Danfoss websites are the main sources for help and information about our company and products. Find product availability, get the latest regional news, or connect with a nearby expert—all in your own language.

Find your local Danfoss website here: [www.danfoss.com/en/choose-region](https://www.danfoss.com/en/choose-region).

### Danfoss Learning



Danfoss Learning is a free online learning platform. It features courses and materials specifically designed to help engineers, installers, service technicians, and wholesalers better understand the products, applications, industry topics, and trends that will help you do your job better.

Create your Danfoss Learning account for free at [www.danfoss.com/en/service-and-support/learning](https://www.danfoss.com/en/service-and-support/learning).

### Spare Parts



Get access to the Danfoss spare parts and service kit catalog right from your smartphone. The app contains a wide range of components for air conditioning and refrigeration applications, such as valves, strainers, pressure switches, and sensors.

Download the Spare Parts app for free at [www.danfoss.com/en/service-and-support/downloads](https://www.danfoss.com/en/service-and-support/downloads).

### Coolselector®2 - find the best components for you HVAC/R system



Coolselector®2 makes it easy for engineers, consultants, and designers to find and order the best components for refrigeration and air conditioning systems. Run calculations based on your operating conditions and then choose the best setup for your system design.

Download Coolselector®2 for free at [coolselector.danfoss.com](https://coolselector.danfoss.com).

### Danfoss A/S

Climate Solutions • [danfoss.com](https://danfoss.com) • +45 7488 2222

Any information, including, but not limited to information on selection of product, its application or use, product design, weight, dimensions, capacity or any other technical data in product manuals, catalogues descriptions, advertisements, etc. and whether made available in writing, orally, electronically, online or via download, shall be considered informative, and is only binding if and to the extent, explicit reference is made in a quotation or order confirmation. Danfoss cannot accept any responsibility for possible errors in catalogues, brochures, videos and other material. Danfoss reserves the right to alter its products without notice. This also applies to products ordered but not delivered provided that such alterations can be made without changes to form, fit or function of the product.

All trademarks in this material are property of Danfoss A/S or Danfoss group companies. Danfoss and the Danfoss logo are trademarks of Danfoss A/S. All rights reserved.