

**Installation guide**

Electric regulating valves  
Type **CCMT 3 – 10 Light**

027R7256

027R7256



<p><b>Refrigerant:</b> R744 For other refrigerants, contact Danfoss.</p>	<p><b>Ambient temperature:</b> Min. -40 °C / -40 °F Max. 50 °C / 122 °F</p> <p><b>Fluid temperature:</b> Min. -20 °C / -4 °F on valve inlet Min. -40 °C / -40 °F on valve outlet Max. 55 °C / 131 °F on valve inlet / outlet</p>	<p><b>Stepper motor type:</b> Bipolar <b>Total full steps:</b> 210 <b>Step rate:</b> 100 stp/s <b>Phase current:</b> 350 mA RMS <b>Coil resistance:</b> 15 ohm</p>
--	--	--

**Max working pressure:**  
Steel Connections : 140 bar / 2030 psig  
Bi-metal Connections : 130 bar / 1885 psig  
**Note!** Bimetal Connections :  
120 bar / 1740 psig for UL approval.

For more language options and more information on the valve refer to the website. [ccmt.danfoss.com](http://ccmt.danfoss.com)

**Flow direction**

Flow direction: A to B

**Controller**

CCMT L

Filter

Recommended <100µm/micron

**! Note!**

- CCMT valves are delivered in open position, ready for brazing.
- Filter with a maximum mesh of 100 µm is recommended to install on the inlet line that can resist particles size above 100 µm.

**! Warning!** Do not connect directly to AC / DC power source. Connect valve to appropriate controller/driver only. Do not operate valve while assembling or disassembling.

**Mounting direction**

**! Warning!**

- Do not disassemble the valve before brazing or welding.
- Valve must be open during brazing and welding.

Fully closed

Open

### Brazing

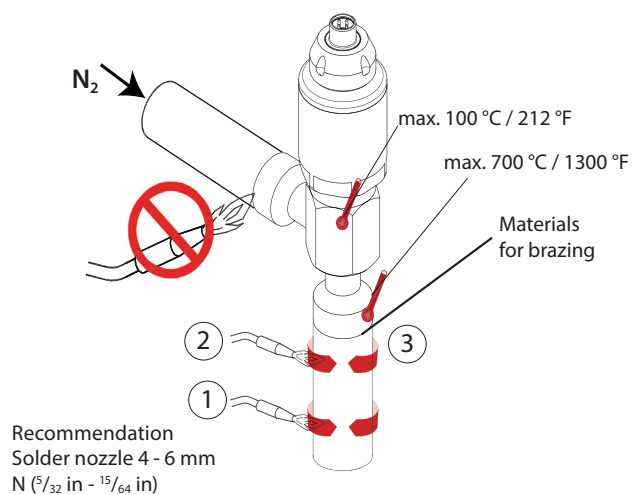

Recommendation  
Solder nozzle 4 - 6 mm  
N (5/32 in - 15/64 in)

Materials used for brazing:

- Flux: Metalli tenacity No. 5 Powder or Braze Tec special h paste.
- Filler: Silver-Flo 55 (BS:AG 14/ DIN L-Ag55 Sn) or Silver-Flo 56 (AWS B Ag-7).

**Warning**

Filler metals containing Phosphor i.e. BS: CP 1/ DIN L-Ag 15P or BS: CP 3/ DIN L-Ag P7 must not be used.

Note: N2 gas from opposite side of soldering point.

### Welding

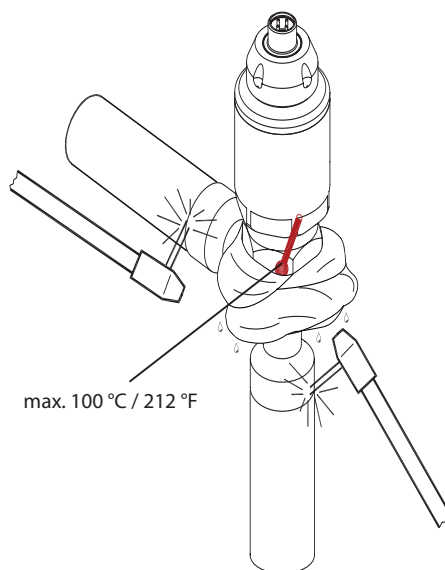

Recommendation for TIG welding

- Power approximately 60A.
- Use Shield gas charge - Argon.
- Material for welding - approximately 2 mm thick stainless steel alloy.

### Bi-Metal Brazing

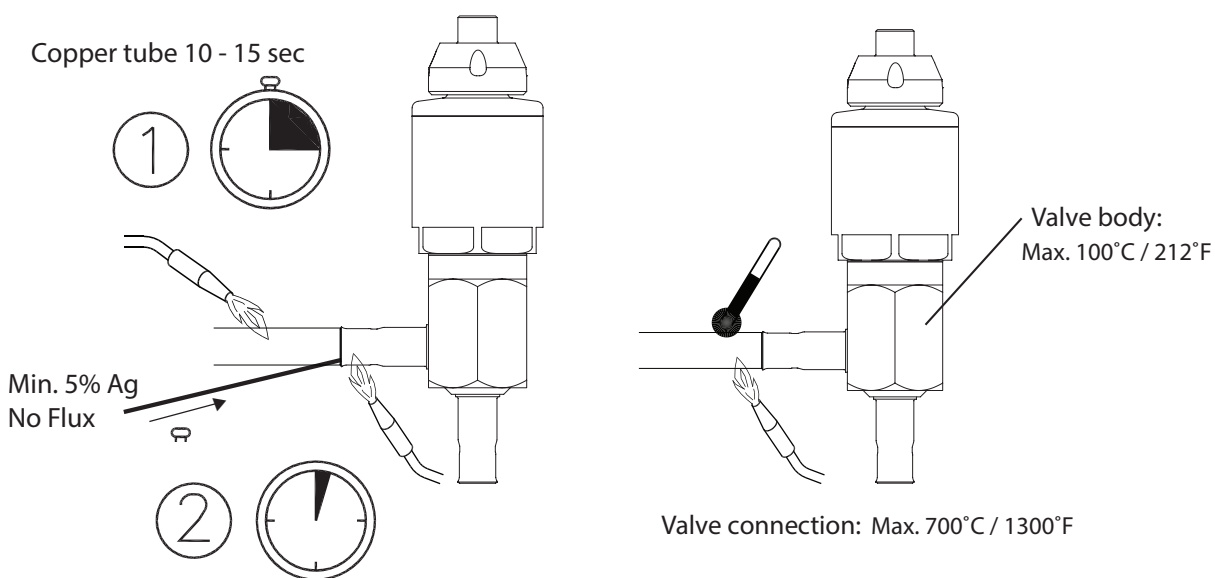

**Electrical connections**

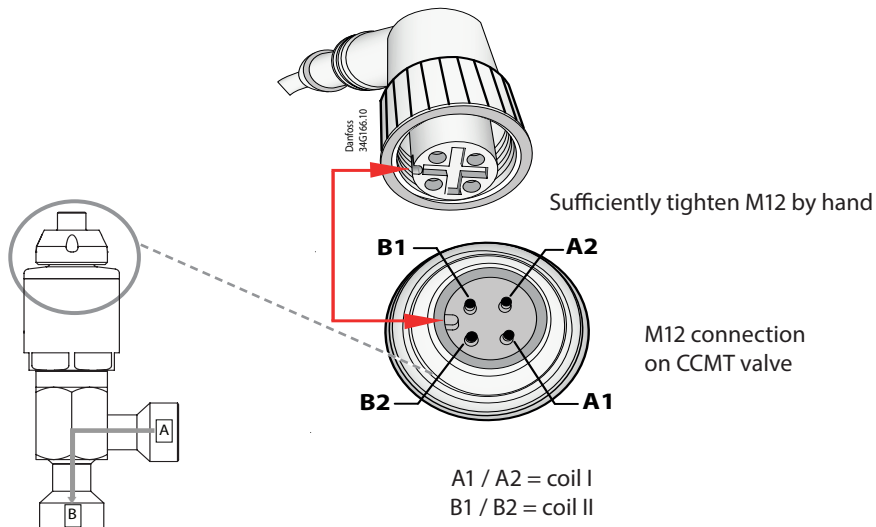

**Insulation**

When used with duty cycle in a range from 20% to 50% or with Danfoss AK-XM 208C stepper driver:

- Insulation is not to be used on valve motor
- Insulation is acceptable on the valve body only

**Note:** operation with duty cycle above 50% is not possible irrespective of insulation method.

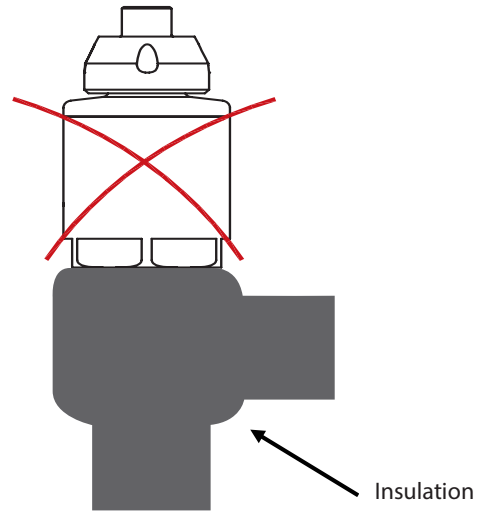

**Warning**

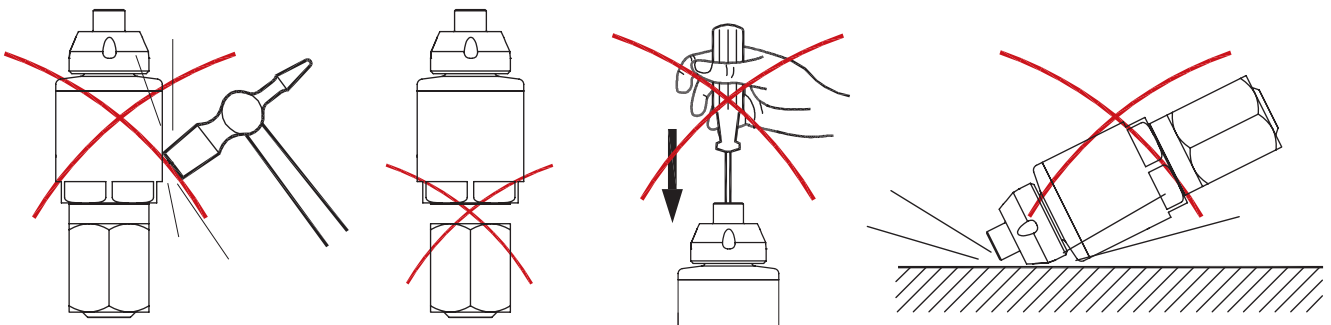

Service only

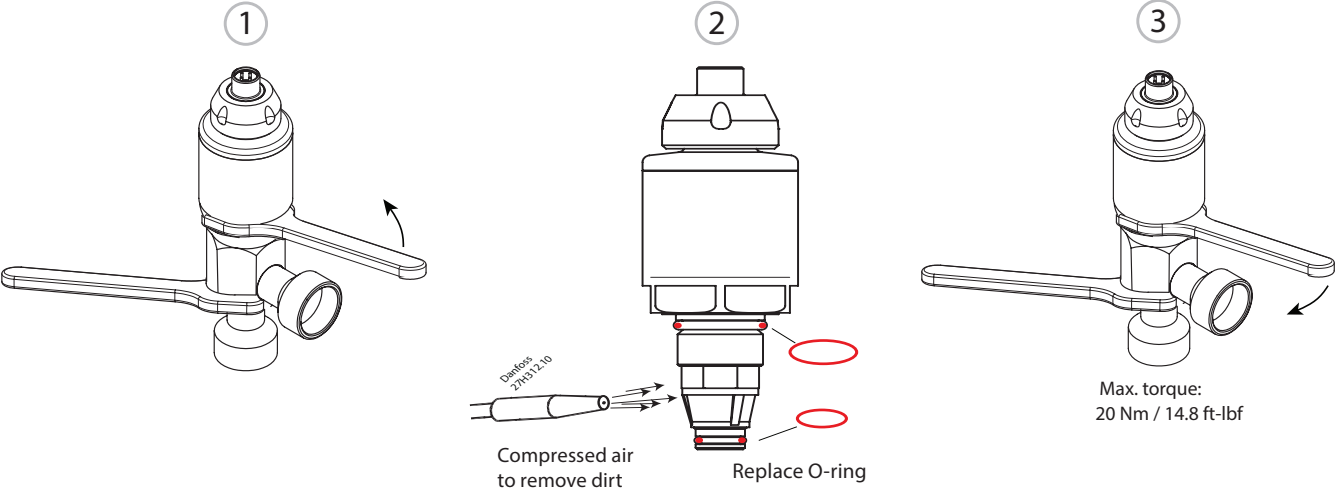

Any information, including, but not limited to information on selection of product, its application or use, product design, weight, dimensions, capacity or any other technical data in product manuals, catalogues, descriptions, advertisements, etc. and whether made available in writing, orally, electronically, online or via download, shall be considered informative, and is only binding if and to the extent, explicit reference is made in a quotation or order confirmation. Danfoss cannot accept any responsibility for possible errors in catalogues, brochures, videos and other material. Danfoss reserves the right to alter its products without notice. This also applies to products ordered but not delivered provided that such alterations can be made without changes to form, fit or function of the product. All trademarks in this material are property of Danfoss A/S or Danfoss group companies. Danfoss and the Danfoss logo are trademarks of Danfoss A/S. All rights reserved.