

GB

Before performing any operation read carefully the IOM supplied with the unit .

This component and these instructions are conceived exclusively for the utilisation in conjunction with a unit of the same manufacturer.

These operations must be carried out exclusively by qualified technician and instructed on possible risks connected to the

operations.

The electric operations must be carried out by qualified electricians at least according to IEC 60364 .

During the operations follow the local safety regulations.

Before starting, disconnect the unit power line.

Check that the earth system is present and effective.

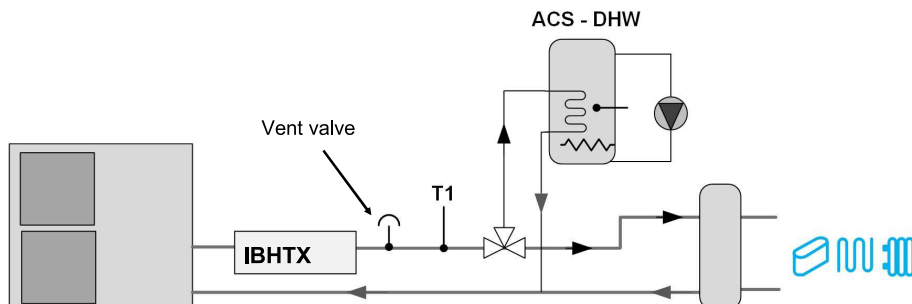

T1= system temperature probe



Vent valve

Install the highest points of tubes in a way that the air can escape from the circuit.

Position

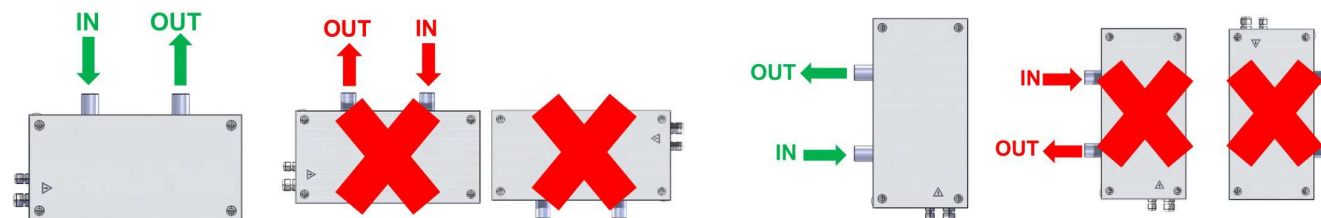

Installation, observe the following distances

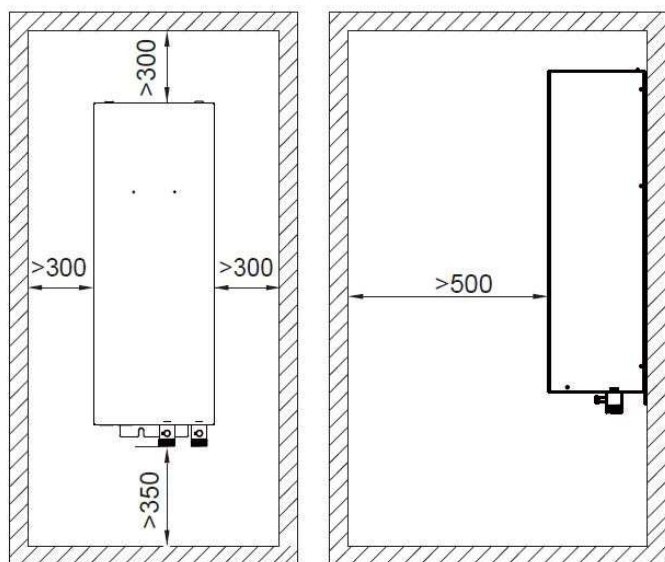

(unit: mm)

The backup heater is designed to be wall mounted in indoor locations only.

Make sure the installation surface is a flat and vertical not combustible wall.

Minimum flow

When installing the backup heater in the system, make sure the required minimum water flow rate is guaranteed at all times.

For more information, refer to the installation manual of the outdoor unit.

3-way or 2-way upstream installation

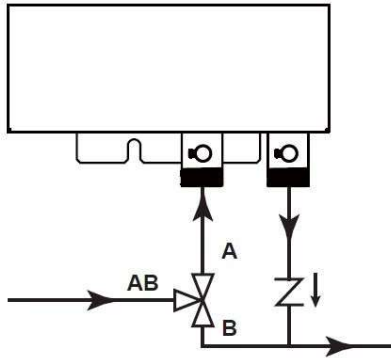

The function of the 3-way valve is to switch the water pipe.
 When we use the heat mode or hot water mode, the water flows AB to A; when we use the cool mode, the water flows AB to B.
 When the outdoor unit is in cool mode, condensation may occur.
 Therefore provide a bypass by installing a valve kit to the water inlet of the backup heater.
 For instructions, refer to the installer reference guide.
 Do NOT install any other valve kit than the one specified in the installer reference guide.

Electrical connection

Kit composition:

- 1 x T1 10m temperature probe (provide a probe holder well)
- 3 x 16A fuses

Remove power supply

Add fuses according to the requested capacity (kW)

FU1 (fuses)		POWER (KW)	=	TOTAL POWER
3x16A	STD	9KW	=	9KW
2x16A	Opt.	6KW	=	6KW
1x16A	Opt.	3KW	=	3KW

Use of the resistances

Remove the phase (L1) of the resistance according to the power used.

- 1 Phase = 3kW
- 2 Phases = 6kW
- 3 Phases = 9kW

Insulate the removed cables, remove unused fuses.

DIP setting

DHW+SYSTEM

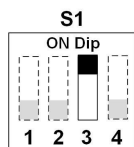

SYSTEM

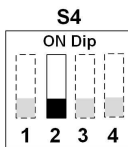

Periodic check (by installer)

1. check fastening of safety thermostats
2. check fastening of power cables

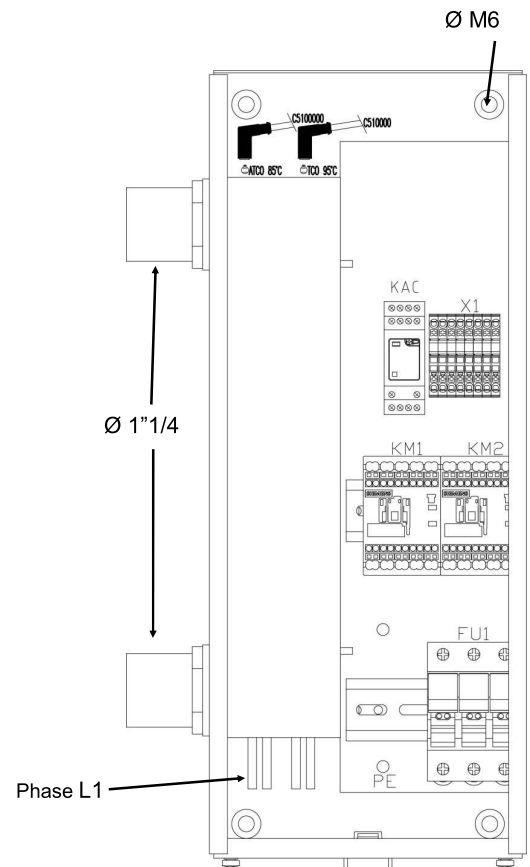

Electrical wiring diagram

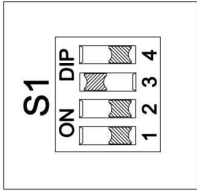
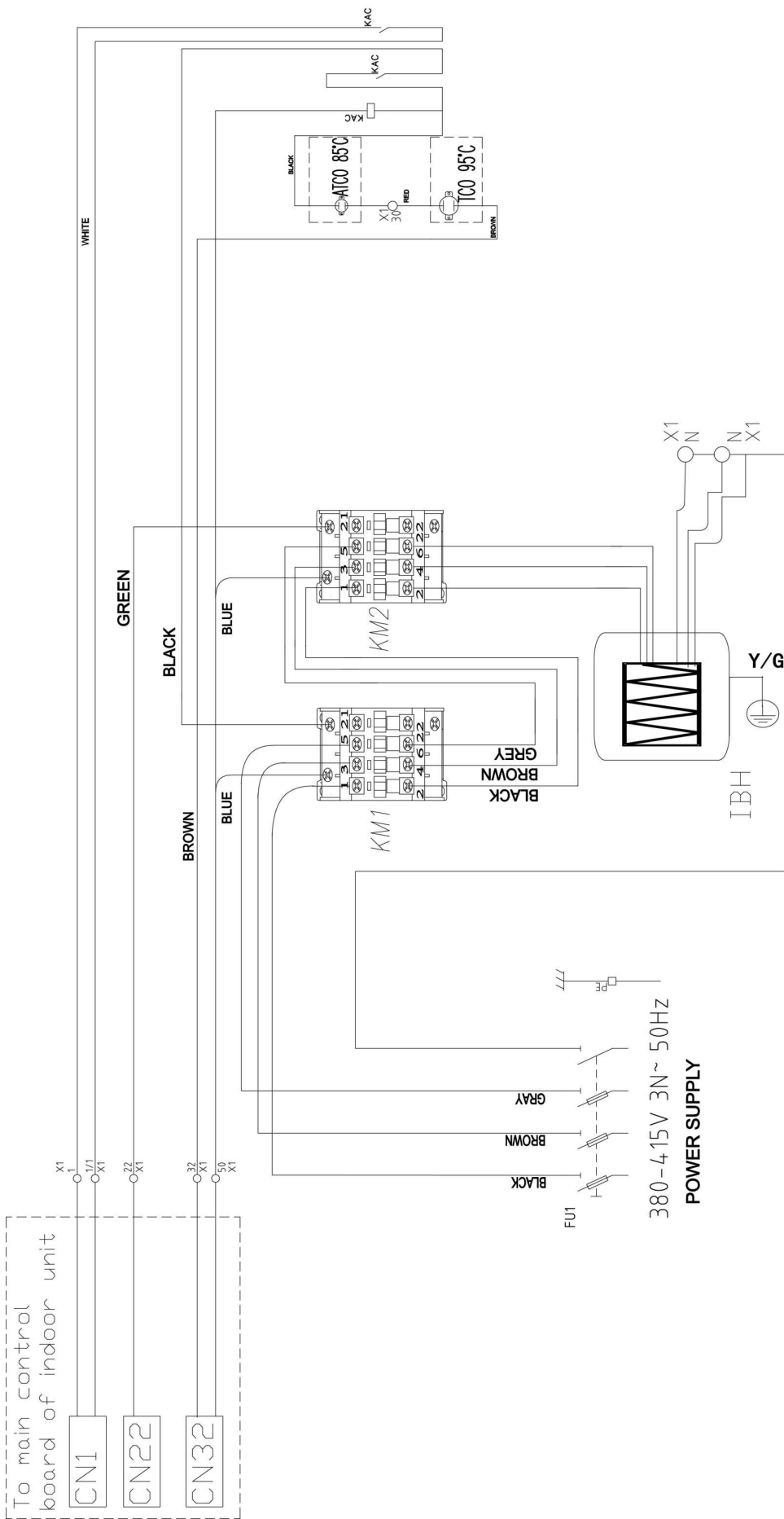

Leakage Protection Switch must be installed to the Power Supply of the electric heating. Equipment must be grounded.

After power off, it will take 5 minutes to power on