

Date 16/6/2020
 Customer
 Offer



San Toribio, 6 28031 MADRID
 +34/913030426 com@frimetal.es

DIRECT EXPANSION EVAPORATOR

FRM-165

Model Capacity **2,9 kW**
 Required Capacity **0,0 kW**

Materials

Tubes Copper
 Fins Aluminium
 Casing Aluminun and galvanized steel white coated RAL-9002

Duties

Fin Spacing **4,2 mm**
 Air Flow **1440 m³/h**
 Air Velocity **1,82 m/s**
 Available Air Static Pressure **0 Pa**
 Air throw **12 m**
 Air Inlet Temperature **3,0 °C**
 Outlet Air Temperature **-1,3 °C**
 Evaporating Temperature **-5,0 °C**
 Temperature difference DT1 **8 K**
 Refrigerant **R449A**

Coil

Fin Spacing **4,2 mm**
 Finned Length **550 mm**
 Surface **14,0 m²**
 Internal Volume **3,0 dm³**

Installer Information

Net weight **24 kg**
 Inlet liquid distributor **1 x 1/2" mm**
 Outlet line **1 x 16 mm**

AC Fan motors ErP compliant

Power supply **1~230V/50Hz** Total absorbed power **80 W**
 Fans Nr. **1** Total absorbed current **0,4 A**
 Blade Diameter **300 mm** Noise Power Level **64 dB(A)**
 Speed **1350 rpm** Noise Pressure Level **33 dB(A)**
 Distance **10 m**

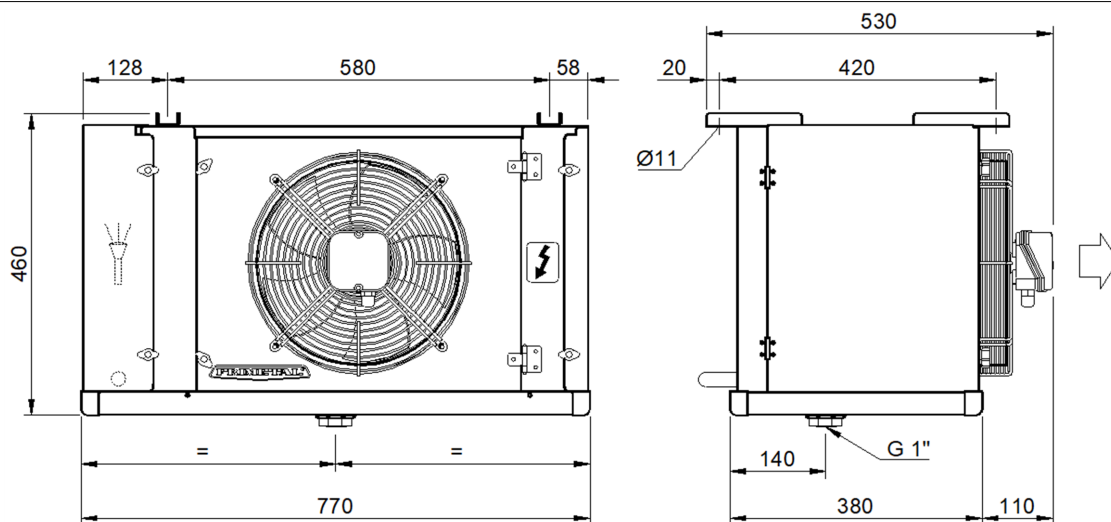

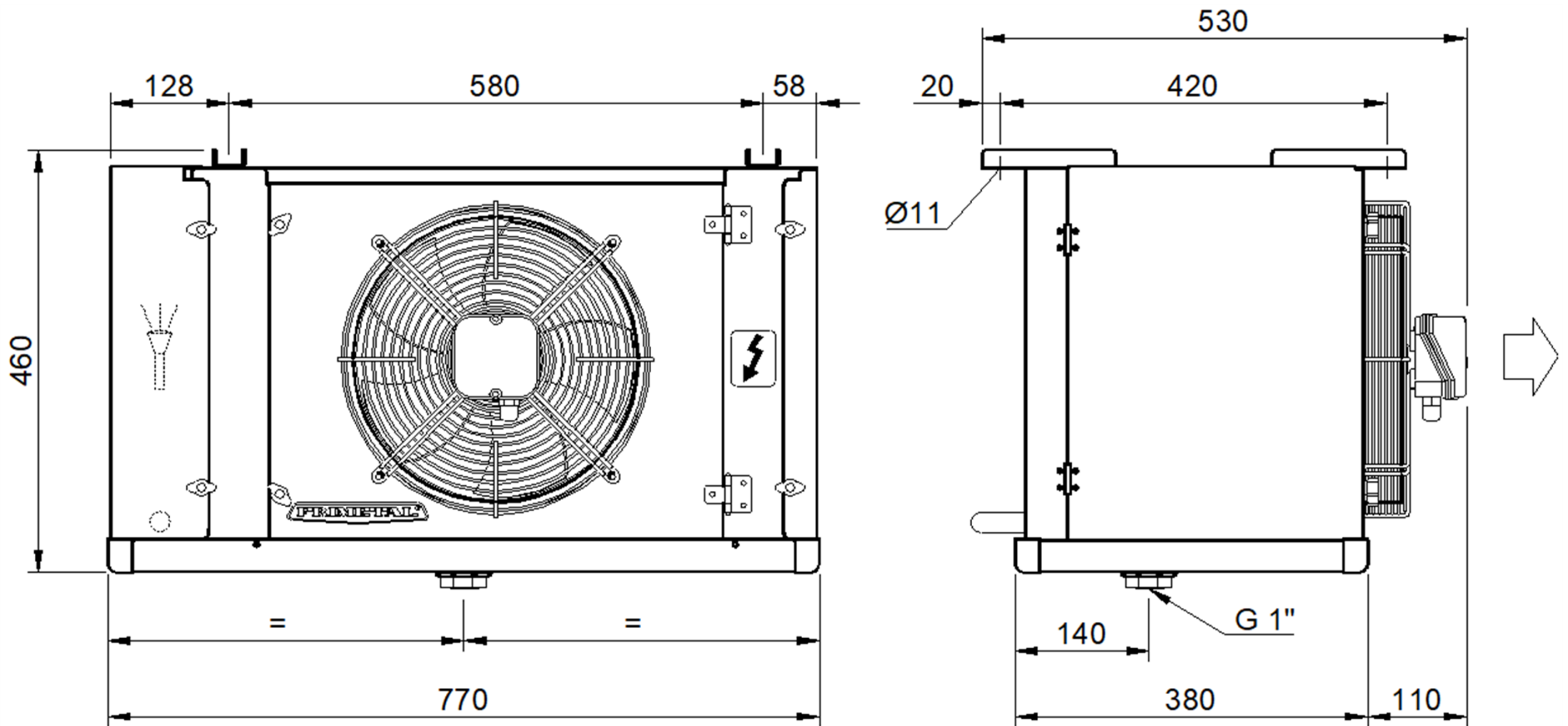

DIRECT EXPANSION EVAPORATOR - FRM-165



FRIMETAL, s.a.
 San Toribio, 6
 28031 MADRID
 +34/913030426 - +34/917774761