

ENGINEERING
TOMORROW

Danfoss

New ICF Flexline™ stainless steel valve station in the dairy industry

Perfect **temperature control** and dairy hygiene: Meet the new Danfoss ICF Flexline™ **stainless steel** valve station

Danfoss now introduces a stainless steel version of its successful ICF Flexline™ valve station, completing the impressive range of stainless steel line products for safe, hygienic and precisely controlled dairy production.

The world's

ONLY

stainless steel
valve station

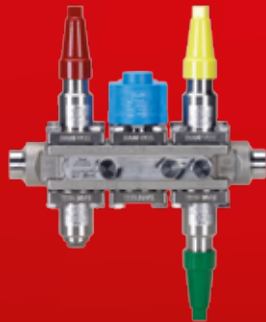

The ICF Flexline™ **stainless steel** valve station from Danfoss

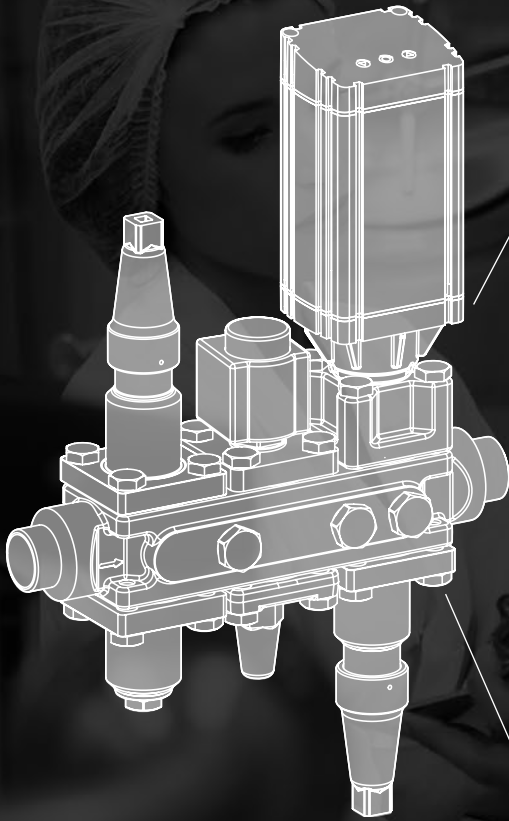

End-user benefits

- Perfectly suited for CO₂-based systems
- Low total cost of ownership
- Precise temperature control for optimum food safety
- Compatible with environmentally friendly refrigerants such as CO₂
- Fewer weldings equal minimized leak risk

Benefits for the contractor

- Easy to do service on your service contracts
- One code number for easier order and spare parts handling
- Less inventory space needed
- Compact design, low weight
- Fewer weldings equal minimized leak risk
- Full systems design freedom

One-stop shop

- Just one supplier needed for all component types
- The only stainless steel valve station in the market
- Innovation from the market leader in refrigeration technology
- Full range of support tools available for free
- Based on the tried and tested ICF stainless steel valve station concept
- Full compatibility with all stainless steel components from Danfoss

TWO

weldings instead
of six or more

Fresh and hygienic dairy production with Danfoss **stainless steel** components

The dairy industry depends on technology that can control temperatures and ensure uncompromising hygiene in every single step of the conversion of fresh milk into finished products. Whether the end product is ice cream, processed milk, cream, yoghurt or some of the many other uses of fresh milk, precise temperature management is absolutely vital.

The Danfoss range of stainless steel products for cooling and refrigeration lets engineers and contractors deliver reliable, efficient and environmentally friendly cooling systems to the global dairy industry. This illustration highlights some of the key processes in the treatment of milk where Danfoss products can ensure safe, hygienic and strictly controlled production of end products.

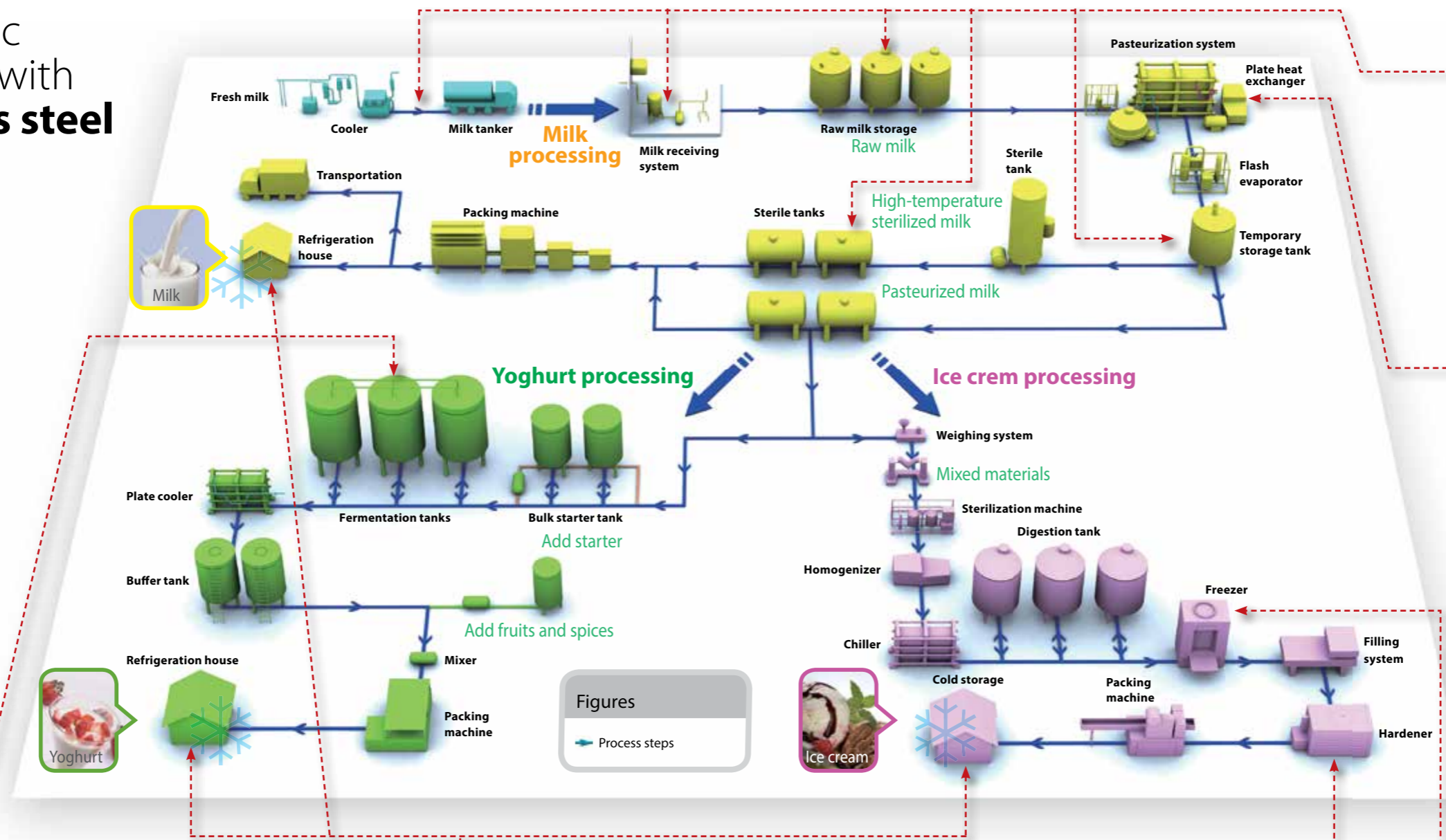

Dairy product cooling
After collection, raw milk needs to be stored at temperatures between +4 °C and +6 °C. Once it has been filtered and pasteurized, the milk must be stored under sterile conditions and under strict temperature control before after-treatment, whether for UHT or direct packaging. The cooling medium is ammonia, CO₂ or ice water.

Pasteurization
Pasteurization involves heating the milk and then rapidly cooling it down to below +4 °C in order to keep enzymes in the milk active. Most often, ice water is used for cooling, either using ammonia or CO₂ heat exchanger.

Fermentation, cooling and maturation
Fermentation by lactic acid cultures and subsequent cooling and maturation are key process in yoghurt production.

Cold storage
After packaging, different dairy products require storage at different temperatures ranging from cool storage for pasteurized milk to very low temperatures for finished ice cream. Cooling media used today are typically ammonia or CO₂.

Hardening
Finished ice cream must be kept at very low, freezing temperatures to fix the shape and desired hardness of the ice cream. The cooling medium is either ammonia or CO₂.

Congelation
The ice cream mix is frozen under agitation and addition of air, which helps form ice crystals and increase volume. Congealing takes place at temperatures between -6 °C and -9 °C.

Product range

SVL SS Flexline™ range:

The SVL SS Flexline™ range consists of a series of stainless steel valves based on the principle of one housing with many possible valve inserts. All functional inserts fit one of the two valve housings available (one straight, one angled), which makes it possible to keep a very low spare part stock and to service the valves quickly and efficiently.



The new Danfoss ICF Flexline™ stainless steel valve station

Max. operating pressure: 52 bar g (754 psig)
Temperature range: -60/+150 °C (-76 +302°F).

EVRs and EVRST stainless steel solenoid valves

Solenoid valves with three different operation types: Direct, servo or forced servo. Operating pressure up to 52 bar in a temperature range from -40 °C to +105 °C, depending on the coil.

OFV-SS stainless steel overflow valves

Three functions in one: Overflow valve, stop valve and check valve. Operating pressure up to 52 bar.

SNV-SS stainless steel needle valve

Compact and light service valves with sturdy design and high flow characteristics. Operating pressure up to 52 bar in a temperature range from -60 °C to +150 °C.

Introducing the world's first **stainless steel** valve station

In dairy production, temperature control and hygiene are essential to ensure safe and consistent quality. Many dairy production facilities rely on stainless steel components to ensure safe and hygienic production environments, and many are also shifting towards using CO₂ as the refrigerant of choice, as it's far safer and far more energy-efficient in daily use.



Replace many valves with one valve station

With the introduction of the new ICF stainless steel valve station from Danfoss, you can design and operate cooling lines for complete dairy systems entirely from stainless steel, which makes it more energy-efficient and hygienic production lines with perfect temperature control characteristics.

One of the major advantages of the ICF stainless steel valve station concept is its compact size. Having just one valve housing for multiple functional inserts eliminates the need for several individual valves placed in-line. It reduces not just the complexity of the

system – and the weight of it – but more importantly, it reduces the number of welding needed, and with it the risk of leaks. Installations based on ICF stainless steel valve stations are much smaller, much easier to install and to service, and far more hygienic than conventional individual products.

A complete stainless steel range

The stainless steel ICF stainless steel valve station comes in two sizes: ICF 20 and ICF 25 with multiple connection types and sizes. It fits perfectly with all other stainless steel products for refrigeration in the dairy processing such as the SVL SS Flexline™ range from Danfoss. See our complete stainless steel offering for industrial refrigeration in this brochure.

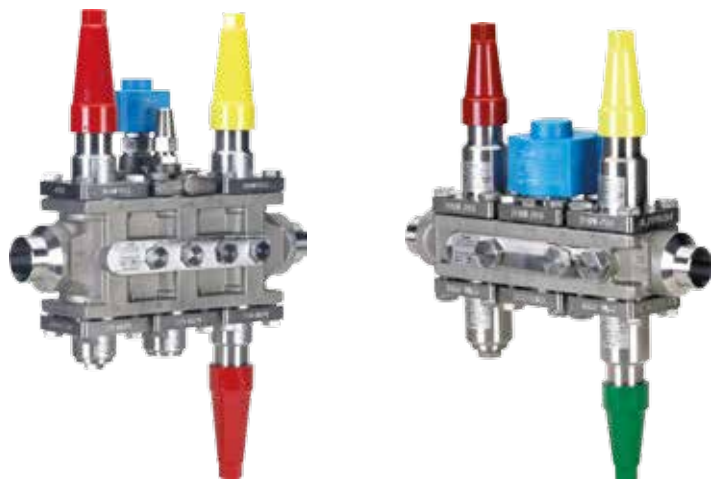

Danfoss Industrial Refrigeration

A world of expertise at the click of a button

Turn to Danfoss if you want to combine quality components with expert knowhow and support. Try out these free tools, designed to make your work much easier.



DIRbuilder

DIRbuilder is designed to make selection processes for industrial refrigeration projects easier and less time-consuming. Specify the valves you need from an extensive pool of configuration options. The DIRbuilder library comprises all Danfoss Industrial Refrigeration valves. Free of charge – no software needed.



Coolselector® 2 – New calculation software for Industrial Refrigeration

Coolselector® 2 is a calculation and support tool for contractors and system designers, offering complete pressure drop calculations, analysis of pipe and valve design and the ability to generate performance reports. It replaces the well-known DIRcalc™ software and offers several new functionalities.



Danfoss IR app

The free IR App gives you a spare parts tool, which makes it easy for you to find the spare part number for a given Danfoss industrial refrigeration valve.



Download 3D CAD symbols

From our online product catalogue on our website, you can download 3D CAD symbols and illustrations to help you when designing refrigeration plants.



IR application tool

With this interactive PowerPoint slideshow, you can explore all the details of a two-stage ammonia plant. You will find detailed cut-away drawings and information on the valves in the installation along with links to videos, literature and product animations.



Application handbook

The Application Handbook is designed to help you every step of the way when working with industrial refrigeration systems. Among many other things, it contains examples of how to select control methods for different refrigeration systems, their design and which components to choose.

Visit www.danfoss.com/IR-tools and find all the tools you need.