



AIR CONDITIONING



REFRIGERATION



HEATING



EN

Universal

CONDENSATE REMOVAL PUMP



The top selling Universal is operated by two air temperature sensors. The peristaltic rotary movement creates a continuous pressure meaning the pump can be sited up to 3m away from the source with no effect in performance.



6.5L/h max. flow



12m max. head (flow rate 6.5L/h)

KEY FEATURES

- Air temp. sensor operated
- Remote install possible
- Pumps contaminated water
- Can run dry

SUITABILITY

- Up to 8.5kW / 29,000Btu/h
- High wall split systems; Ducted units; Floor standing & Chassis units
- ✓ **Perfect for...** Air temperature operation

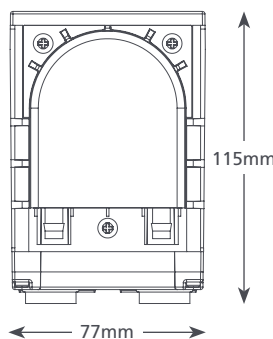
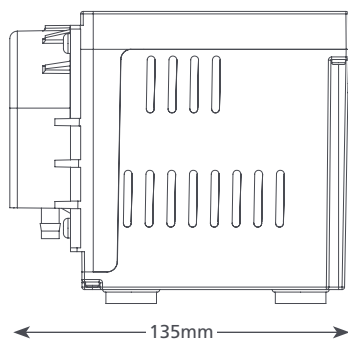

1.35 kg

UNIVERSAL @ 230 VAC 50Hz	
Max. flow	6.5L/h @ 12m head
Max. head	12m
Max. suction lift	3m
dB(A) @ 1m	47
Power supply	230 VAC, 0.2A, 50/60Hz
Rated Class	Continuously I appliance
Max. unit output	8.5kW / 29,000Btu/h
Max. water temp	40°C / 104°F
Inlet/outlet	6mm ID
IP Protection	IP21
Safety switch	n/a
Thermal protection	✓
Fully potted	n/a
Self priming	✓

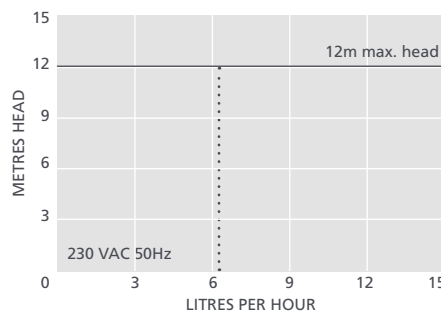

UNIVERSAL OPTIONS	
Universal	FP2082/2

SUGGESTED XTRA ACCESSORIES	
Description	Part No.
Peri Spare Tube Kit	FP1282
1 Amp Fuse	FP2620
Tube To Soil Stack Adaptor	FP2038

Xtra For more installation accessories take a look at our Aspen Xtra range

IN THE BOX
Universal pump • 3m Plug & play power / sensor cable • Wall mounted bracket • Fixing kit • Install manual

- Download manual at aspenpumps.com
- View install video at aspenpumps.com

Information correct at time of going to press.



aspenpumps.com

+44 (0)1323 848842

sales@aspenpumps.com

reliable | silent | simple