

## Data Sheet

# Pilot operated servo valve Type **ICSH 25-80**

65 bar valves for 2 step opening of hot gas lines for defrosting



ICSH dual position solenoid valve belongs to the ICV family and consists of an ICV housing, an ICS insert together with an ICSH top cover with 2 EVM normally closed solenoid pilots installed in the top cover.

All sizes of ICSH are designed for a MWP of 65 bar.

ICSH is used in hot gas lines for the opening of hot gas defrost flow to the evaporator in 2 steps. Both steps are activated by a controller or a PLC energizing the magnetic coils in a time delay sequence.

Step 1 (approx. 20% of full flow) is to allow a smooth pressure build-up in the evaporator, while the subsequent step 2 opens the flow to 100% to get the full defrost capacity.

The ICSH is designed for large industrial refrigeration systems with ammonia, fluorinated refrigerants or CO<sub>2</sub>.

The ICSH features 2 configuration options, which is established at site.

First option is dependent configuration, which secures that step 2 can never open unless step 1 has been mechanically activated.

Second option is independent configuration that allows step 2 to open disregarding step 1. By choosing the independent option attention should be paid to the risk of liquid hammering in case the step 1 for any reason is disregarded.

## Features

- Designed for Industrial Refrigeration applications for a maximum working pressure of 65 bar / 943 psig.  
**NOTE:** Operating valve MWP is dependent on MWP of installed pilots.
- Applicable to HCFC, HFC, R717 (Ammonia) and R744 (CO<sub>2</sub>).
- Direct welded connections.
- Connection types include butt weld, socket weld and solder connections.
- Low temperature steel body.
- Low weight and compact design.
- 2-wire connection for use with a timer relay or 4 wire connection for connecting to a controller or a PLC.
- The ICSH main valve top cover can be oriented in any direction without the function of pilot valves being affected.
- Stabilizes working conditions and eliminates pressure pulsations during opening of hot gas.
- Manual opening possible.
- PTFE seat provides excellent valve tightness.
- Service friendly design.

**Function**

**Figure 1: Dependent configuration**

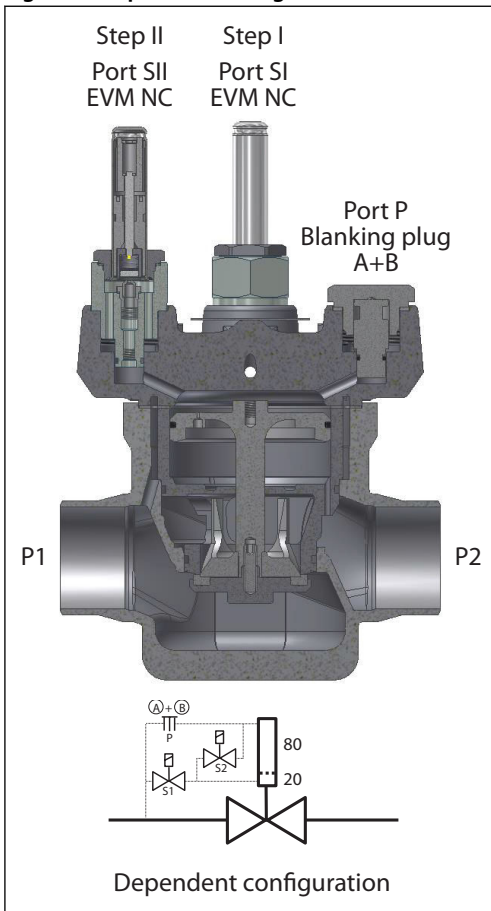

**Figure 2: Independent configuration**

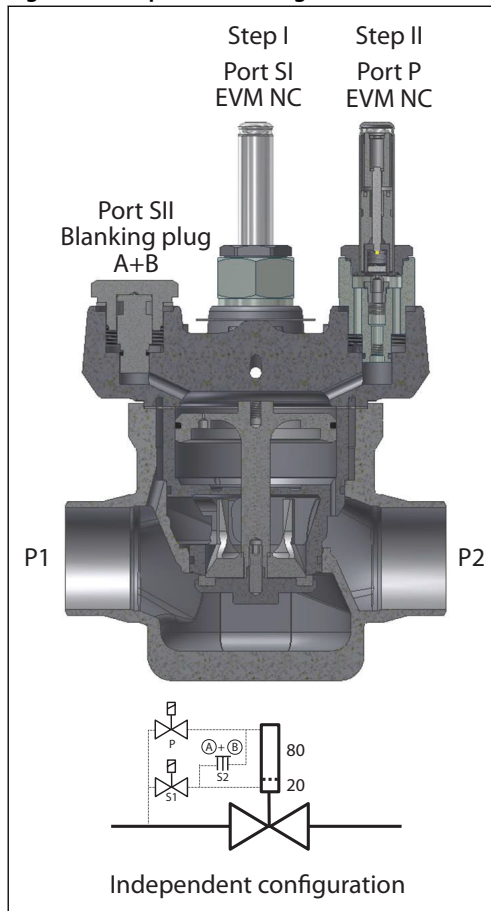

**Figure 3: Supply flow**

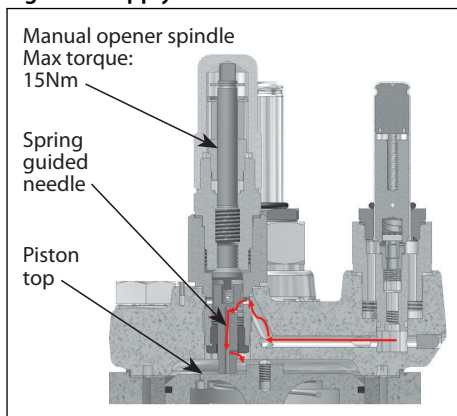

**Figure 4: Supply flow**

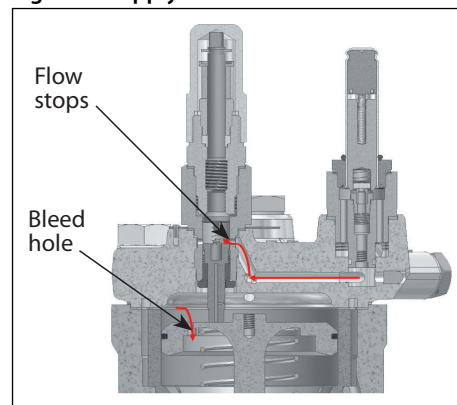

The ICSH is designed for a 2 step opening of the hot gas flow for the evaporator defrost. Step 1 (20% capacity) is intended for a smooth pressure build up in the evaporator - step 2 will open for full capacity.

The valve is pilot controlled by 2 standard EVM Normally Closed valves and the 2 EVM's are controlled by an external controller like PLC.

The external controller simply needs to activate the 2 EVM coils in a sequence with a certain time offset.

The time offset depends on the specific conditions around the ICSH and must be determined at site.

The opening of the ICSH is done by a pressure difference between the inlet pressure P1 and the outlet pressure P2, and for the main valve to open fully, a  $\Delta p$  of 0.2 bar (2.9 psi) is needed.

The ICSH main valve can be configured into 2 different configurations: Dependent or Independent.

**The Dependent setup** (Figure 1: [Dependent configuration](#)) means that fully open (step 2) can only be performed if step 1 is performed successfully. If step 1 for some reason fails, the valve will not open at all.

The matching control program should, in this case, be to activate step 1 coil followed by activation of step 2 coil.

Dependent setup is done by installing the 2 EVM's in Port SI (step 1) and Port SII (step 2), and blanking off the P port with Blanking plug A+B.

**The Independent setup** (Figure 2: [Independent configuration](#)) involves the option to force step 2 to open independent of the result of step 1.

The matching control program should also in this case be to activate step 1 coil followed by activation of step 2 coil. When step 2 is activated the full flow will immediately be started.

**ⓘ ATTENTION:**

A risk of liquid hammering in the system may appear.

Independent setup is done by installing the 2 EVM's in Port SI (step 1) and Port P (step 2), and blanking off the SII port with Blanking plug A+B.

The internal channel structure allows in both configurations a direct flow to the step 1 EVM. By activating step 1 the flow will continue through the spring guided needle that is resting on the top of the piston (see [Figure 3: Supply flow](#)).

The flow will build up a pressure on top of the piston, which will start moving down i.e. start open the main valve. The spring guided needle follows the pistons movement downwards and after a predefined distance the needle reaches its stop position, where the needle closes the supply flow (see [Figure 4: Supply flow](#)).

The bleed hole in the piston top will allow a certain flow out of the pressurized chamber thus enable the piston to move upwards, but any movement of the piston is now being controlled by the needle that compensates by opening the supply flow.

The needle will balance the supply/bleed flows and keep the piston at this position. Step I flow - equivalent to approx. 20% of capacity - has now been established.

After a predetermined period of time the step II coil is activated.

In dependent set-up further flow can only reach the step II EVM if step I EVM is open (working properly). In independent set-up further flow can reach the step II EVM regardless the status of step I.

Once flow is passing through step II EVM it continues to the top of the piston and moves the piston to full open position.

For both configurations the valve will close and stay closed when both coils are de-energised.

The closing is achieved by drainage through the bleed hole.

ICSH is including a manual opener like all the valves in the ICV family. The operation of the opener is done by turning the spindle clockwise (opening the valve) or counterclockwise (closing the valve).

**ⓘ ATTENTION:**

Attention should be paid to the maximum torque applied to the spindle when turning: **Never exceed 15 Nm to the spindle in any direction.**

## **Controller and Wiring**

The 2 steps need to be activated from a PLC in a time delay sequence. The time delay itself must be determined on site since local conditions are decisive.

The wiring from the controller to the 2 coils can be done by either one or two cables.

## Pilot operated servo valve, type ICSH 25-80

By one cable layout only one signal is needed though an additional timer relay has to be connected according to the figure to the right.

Two cable layout requires two subsequent output signals from the PLC.

**Figure 5: Wire connection**

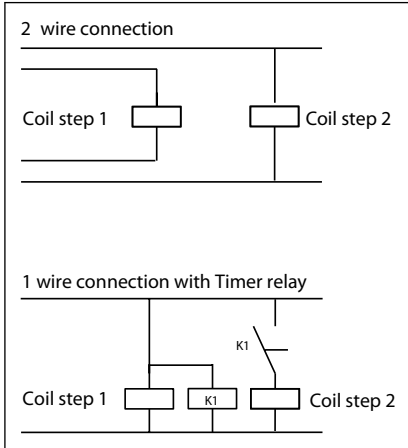

## Media

### **Refrigerants**

Applicable to HCFC, HFC, R717 (Ammonia) and R744 (CO<sub>2</sub>).

### **New refrigerants**

Danfoss products are continually evaluated for use with new refrigerants depending on market requirements.

When a refrigerant is approved for use by Danfoss, it is added to the relevant portfolio, and the R number of the refrigerant (e.g. R513A) will be added to the technical data of the code number. Therefore, products for specific refrigerants are best checked at [store.danfoss.com/en/](https://store.danfoss.com/en/), or by contacting your local Danfoss representative.

**Product specification**

**The ICSH Concept**

The ICSH concept is developed to highest flexibility of direct welded connections. For valve sizes ICV 25 – ICV 65 a wide range of connection sizes and types is available.

The direct welded (non-flanged) connections secure low risk of leakage.

There are five valve bodies available (ICSH 80 makes use of ICV 65 housing).

**Table 1: Valve sizes**

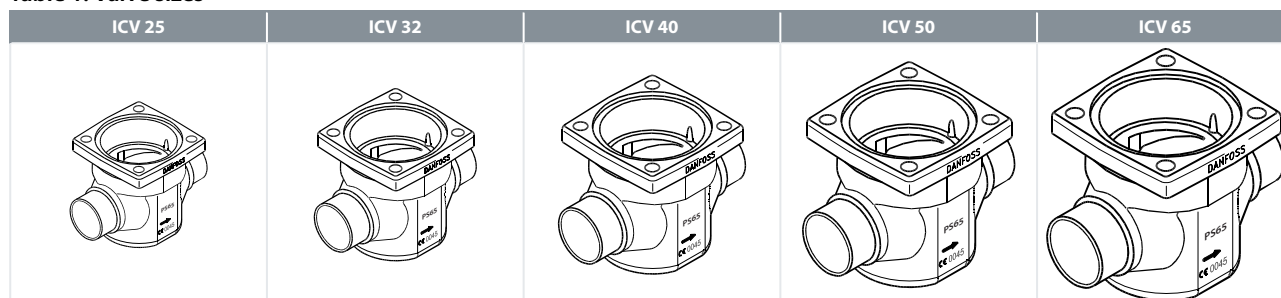

**Table 2: Connections**

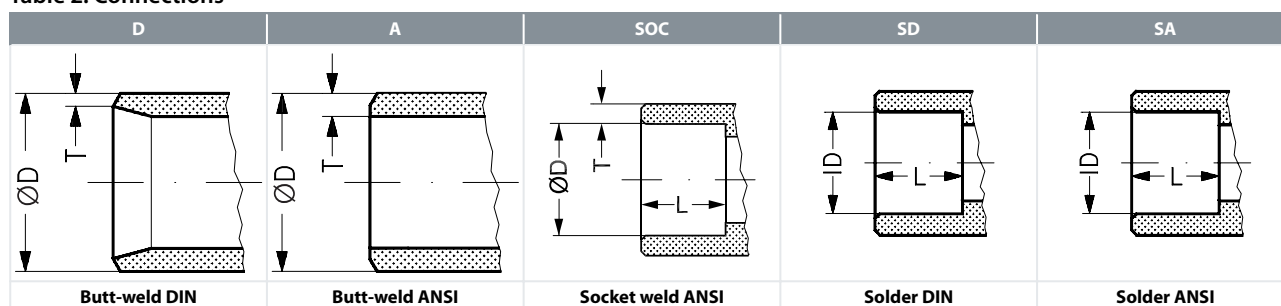

**Design (valve)**

The ICSH valves are approved in accordance with the European standard specified in the Pressure Equipment Directive and are CE marked.

For further details / restrictions - see Installation Instruction.

Valve body and top cover material Low temperature steel

**Technical data**

**Temperature range**

Media: -60 °C / +120 °C (-76 °F / +248 °F).

**Pressure**

The valve is designed for a max. working pressure of 65 bar / 943 psig.

**NOTE:** Operating valve MWP is dependent on MWP of installed pilots. (not all pilots are designed for a MWP of 65 bar).

Step 1 20% capacity of step 2 (full capacity)

**Surface protection**

The ICSH external surface is zinc-chromated to provide good corrosion protection.

**Min. opening pressure differential**

0.2 bar (2.9 psi) higher inlet pressure than outlet pressure for fully open.

**Coil requirements:** Both coils to be IP67.

## Pilot operated servo valve, type ICSH 25-80

---

**Table 3: ICSH capacity values**

	ICSH 25-25	ICSH 32	ICSH 40	ICSH 50	ICSH 65	ICSH 80
$k_v$ (m <sup>3</sup> /h) (full capacity)	11.5	17	27	44	70	85
$C_v$ (USgal/min) (full capacity)	13.3	20	31	51	81	98



## Connections

There is a wide range of connection types available with ICSH valves:

- D: Butt weld, EN 10220
- A: Butt weld, ANSI (B 36.10)
- SOC: Socket weld, ANSI (B 16.11)
- SD: Solder connection, EN 1254-1
- SA: Solder connection, ANSI (B 16.22)

Figure 6: D: Butt-weld

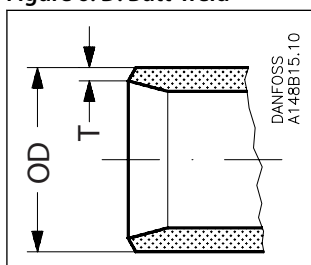

Table 4: Butt-weld (EN 10220)

Size mm	Size in.	ØD mm	T mm	ØD in.	T in.
20	(¾)	26.9	2.3	1.059	0.091
25	(1)	33.7	2.6	1.327	0.103
32	(1¼)	42.4	2.6	1.669	0.102
40	(1½)	48.3	2.6	1.902	0.103
50	(2)	60.3	2.9	2.37	0.11
65	(2½)	76.1	2.9	3	0.11
80	(3)	88.9	3.2	3.50	0.13

Figure 7: A: Butt-weld ANSI

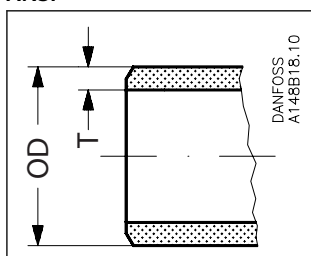

Table 5: Butt-weld ANSI (B 36.10)

Size mm	Size in.	ØD mm	T mm	ØD in.	T in.	Schedule
(20)	¾	26.9	4.0	1.059	0.158	80
(25)	1	33.7	4.6	1.327	0.181	80
(32)	1¼	42.4	4.9	1.669	0.193	80
(40)	1½	48.3	5.1	1.902	0.201	80
(50)	2	60.3	3.9	2.37	0.15	40
(65)	2½	73.0	5.2	2.87	0.20	40
(80)	3	88.9	5.5	3.50	0.22	40

Figure 8: SOC: Socket welding ANSI

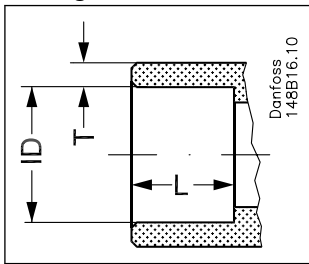

Table 6: Socket welding ANSI (B 16.11)

Size mm	Size in.	ID mm	T mm	ID in.	T in.	L mm	L in.
(20)	¾	27.2	4.6	1.071	0.181	13	0.51
(25)	1	33.9	7.2	1.335	0.284	13	0.51
(32)	1¼	42.7	6.1	1.743	0.240	13	0.51
(40)	1½	48.8	6.6	1.921	0.260	13	0.51
(50)	2	61.2	6.2	2.41	0.24	16	0.63
(65)	2½	74	8.8	2.91	0.344	16	0.63

Figure 9: SD: Soldering

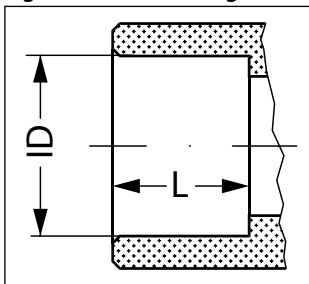

Table 7: SD: Soldering (EN 1254-1)

Size mm	ID mm	L mm
22	22.08	16.5
28	28.08	26
35	35.07	25
42	42.07	28
54	54.09	33
76	76.1	33

Figure 10: SA: Soldering

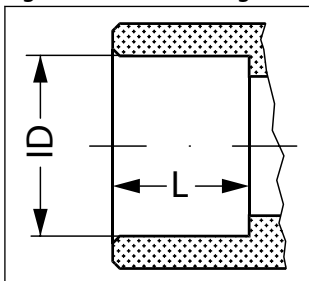

Table 8: SA: Soldering (ANSI B 16.22)

Size in.	ID in.	L in.
¾	0.875	0.650
1½	1.125	1.024
1¾	1.375	0.984

## Pilot operated servo valve, type ICSH 25-80

Size in.	ID in.	L in.
1½	1.625	1.102
2½	2.125	1.300
2½	2.625	1.300

### Material specification

Figure 11: ICSH

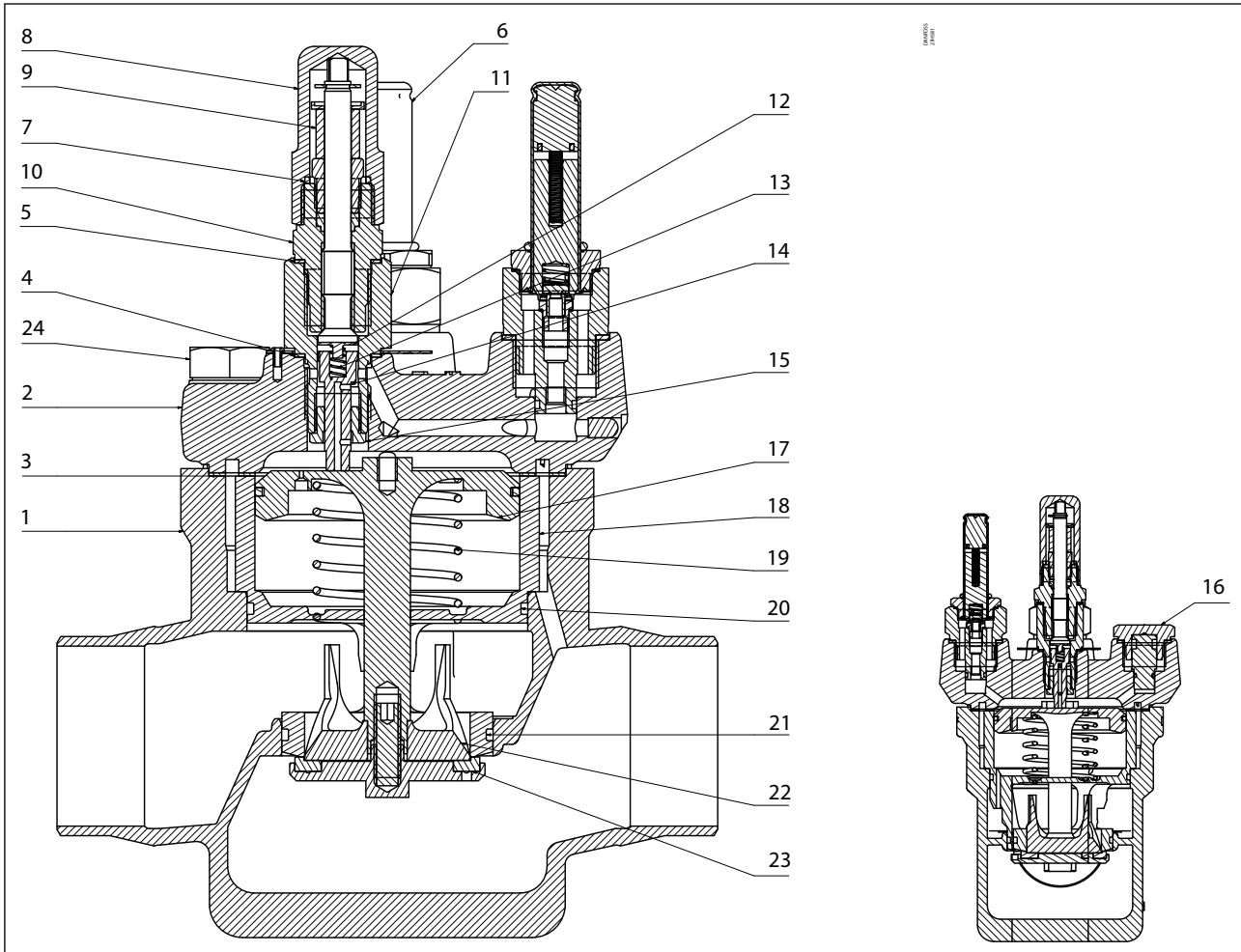

Table 9: Material and parts list

No	Part	Material	EN	ASTM
1	Body	Low temperature Steel	G20Mn5QT EN 10213-3	LCC A352
2	Top Cover	Low temperature Steel	P285QH EN-10222-4	LF2 A350
3	Gasket	Fibre non asbestos		
4	Gasket	Aluminium		
5	Gasket	Aluminium		
6	EVM NC			
7	Gasket	Nylon		
8	Cap	Steel		
9	Stopper	Nylon		
10	Manual opener	Steel		
11	Needle Housing	Stainless steel		
12	Spring Bush	Stainless steel		
13	Spring	Steel		
14	Needle	Stainless steel		
15	Nozzle	Cast iron		
16	Plug	Steel		
17	Piston	Steel		

## Pilot operated servo valve, type ICSH 25-80

No	Part	Material	EN	ASTM
18	Cylinder	Steel		
19	Spring	Steel		
20	O-ring	Chloroprene (Neoprene)		
21	O-ring	Chloroprene (Neoprene)		
22	Cone	Steel		
23	Valve Plate	PTFE		
24	Bolt	Stainless steel	A2-70 EN1515-1	A2-70, B1054

### Valve selection based on capacity calculation

As for extended capacity calculations and valve selection based on capacities and refrigerants, please refer to Coolselector®2. Rated and extended capacities are calculated with the Coolselector®2 calculation engine to ARI standards with the ASEREP equations based on laboratory measurements of selected valves.

Download Coolselector®2 for free at [coolselector.danfoss.com](http://coolselector.danfoss.com).

### Dimensions

Figure 12: ICSH

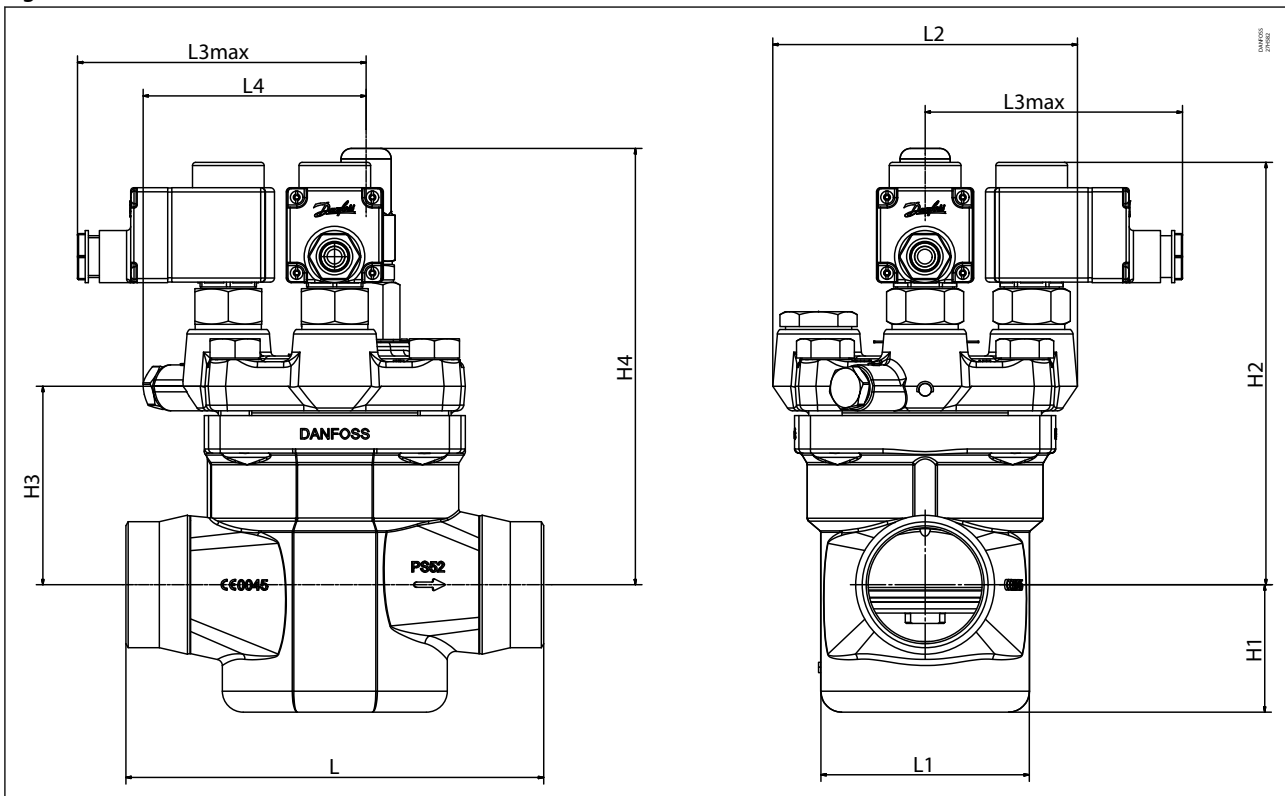

Table 10: ICSH 25-25

ICSH 25-25	L		
	DIN	A	SOC
mm	135	135	147
in	5.31	5.31	5.79

Table 11: ICSH 25-25

ICSH 25-25	L1	L2	L3max(s1)	L3max(S-2)	L4	H1	H2	H3	H4	Weight
mm	65	146.5	138	123	100.5	39.5	168.5	61	174	3.8 Kg
in	2.56	5.77	5.43	4.84	3.96	1.56	6.63	2.40	6.85	7.93lb

## Pilot operated servo valve, type ICSH 25-80

**Table 12: ICSH 32**

ICSH 32	L		
	DIN	A	SOC
mm	145	145	148
in	5.71	5.71	5.83

**Table 13: ICSH 32**

ICSH 32	L1	L2	L3max(s1)	L3max(S-2)	L4	H1	H2	H3	H4	Weight
mm	75	146.5	138	123	102	42.5	182	72	187.6	5.1 Kg
in	2.95	5.77	5.43	4.84	4.02	1.67	7.17	2.83	7.39	11.1 lb

**Table 14: ICSH 40**

ICSH 40	L		
	DIN	A	SOC
mm	160	160	180
in	6.30	6.30	7.09

**Table 15: ICSH 40**

ICSH 40	L1	L2	L3max(s1)	L3max(S-2)	L4	H1	H2	H3	H4	Weight
mm	86	146	138	123	102	51.5	186.5	78	193	6.5 Kg
in	3.39	5.75	5.43	4.84	4.02	2.03	7.34	3.07	7.60	14 lb

**Table 16: ICSH 50**

ICSH 50	L		
	DIN	A	SOC
mm	200	200	216
in	7.87	7.87	8.50

**Table 17: ICSH 50**

ICSH 50	L1	L2	L3max(s1)	L3max(S-2)	L4	H1	H2	H3	H4	Weight
mm	100	146	138	123	107	61	202	95	209	9.4 Kg
in	3.94	5.75	5.43	4.84	4.21	2.40	7.95	3.74	8.23	20.3lb

**Table 18: ICSH 65**

ICSH 65	L		
	DIN	A	SOC
mm	230	230	230
in	9.06	9.06	9.06

**Table 19: ICSH 65**

ICSH 65	L1	L2	L3max(s1)	L3max(S-2)	L4	H1	H2	H3	H4	Weight
mm	130	145.6	138	123	106.7	69	222.5	114.5	232	13.7 Kg
in	5.12	5.73	5.43	4.84	4.20	2.72	8.76	4.51	9.13	29.8lb

**Table 20: ICSH 80**

ICSH 80	L	
	DIN	A
mm	245	245
in	9.65	9.65

**Table 21: ICSH 80**

ICSH 80	L1	L2	L3max(s1)	L3max(S-2)	L4	H1	H2	H3	H4	Weight
mm	130	145.6	138	123	106.7	69	222.5	112.5	232	13.7 Kg
in	5.12	5.73	5.43	4.84	4.20	2.72	8.76	4.43	9.13	29.8lb

**NOTE:**

Specified weights are approximate values only.

**Ordering**

**ICSH 25**

Ordering from the parts programme

Figure 13: Example (select from below tables ICV 25 valve body w/different connections, ICS 25 function module and ICSH 25 top cover)

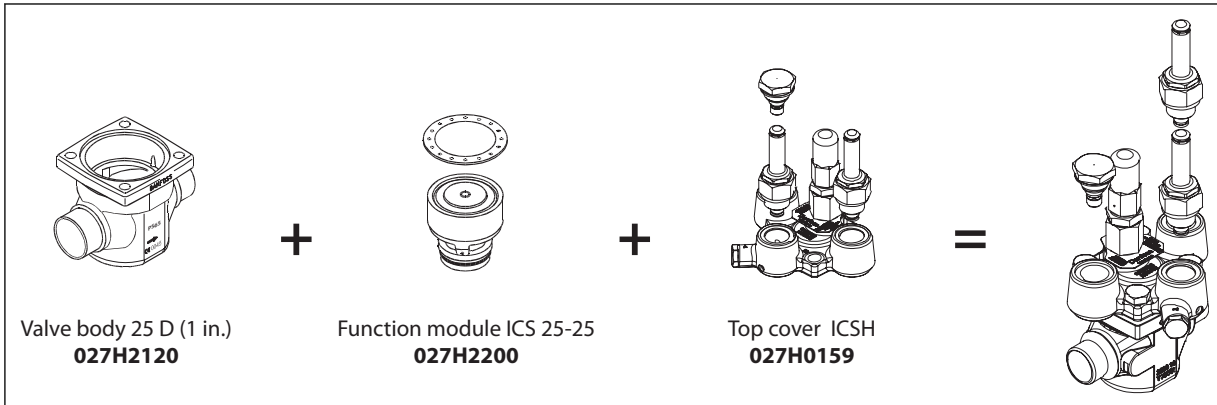

Figure 14: ICV 25 valve body

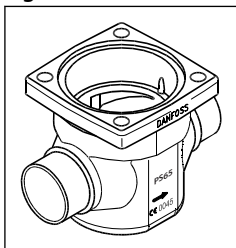

Table 22: ICV 25 valve body w/different connections

Valve size	Code Number
20 D (¾ in.)	027H2128
35 SD (1⅝ in. SA)	027H2134
22 SD (⅞ in.)	027H2123
20 SOC (¾ in.)	027H2132
25 D (1 in.)	027H2120
28 SA (1⅝ in.)	027H2126
20 A (¾ in.)	027H2131
25 SOC (1 in.)	027H2122
32 D (1¼ in.)	027H2129
22 SA (⅞ in.)	027H2125
25 A (1 in.)	027H2121
20 FPT (½ in.)	027H2133
40 D (1½ in.)	027H2135
28 SD (1⅝ in.)	027H2124
32 A (1¼ in.)	027H2130
25 FPT (1 in.)	027H2127

- D** = Butt-weld DIN
- A** = Butt-weld ANSI
- J** = Butt-weld JIS
- SOC** = Socket weld ANSI
- SD** = Solder DIN
- SA** = Solder ANSI
- FPT** = Female Pipe Thread

Figure 15: ICS 25

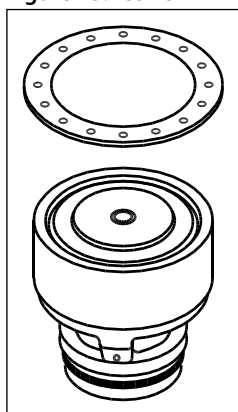

Table 23: ICS 25 function module

Description	Code Number
ICS 25-5	027H2201 <sup>(1)</sup>
ICS 25-10	027H2202 <sup>(1)</sup>
ICS 25-15	027H2203 <sup>(1)</sup>
ICS 25-20	027H2204 <sup>(1)</sup>
ICS 25-25	027H2200 <sup>(1)</sup>

<sup>(1)</sup> Including gasket and O-rings

Figure 16: ICSH 25 top cover

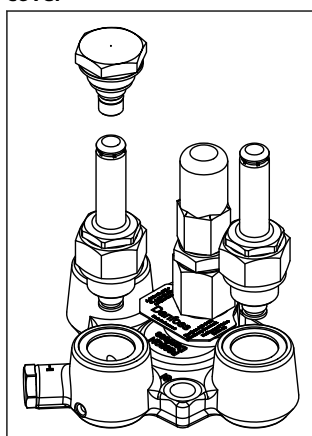

Table 24: ICSH 25 top cover

Description	Code Number
Top cover ICSH	027H0159 <sup>(2)</sup>

<sup>(2)</sup> Including bolts, one blanking plug (A+B) and 2 EVM NC

**Ordering complete factory assembled valve**  
(body, function module and top cover)

Figure 17: Valve assembly

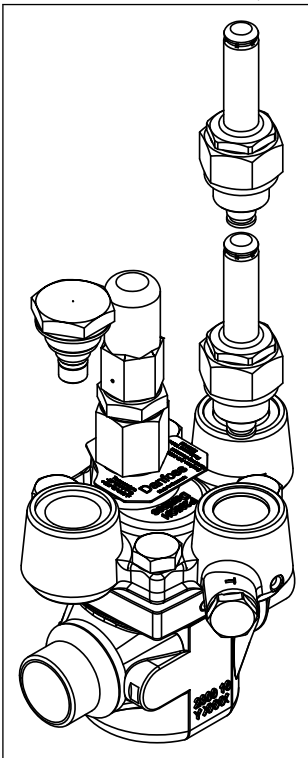

Table 25: ICSH 25-25 connections

	Available connections							
	20 D (3/4 in.)	25 D (1 in.)	32 D (1 1/4 in.)	40 D (1 1/2 in.)	35 SD (1 3/8 in. SA)	28 SA (1 1/8 in.)	22 SA (7/8 in.)	28 SD (1 1/8 in.)
ICSH 25-25 <sup>(a)</sup>	*	027H2309	*	*	*	*	*	*
	22 SD (7/8 in.)	20 A (3/4 in.)	25 A (1 in.)	32 A (1 1/4 in.)	20 SOC (3/4 in.)	25 SOC (1 in.)	20 FPT (1/2 in.)	25 FPT (1 in.)
ICSH 25-25 <sup>(a)</sup>	*	*	027H2308	*	*	027H2307	*	*

<sup>(a)</sup> Including one blanking plug (A+B) and 2 EVM NC

## ICSH 32

Ordering from the parts programme

Figure 18: Example (select from table ICV 32 valve body w/different connections, ICS 32 function module and ICSH 32 top cover)

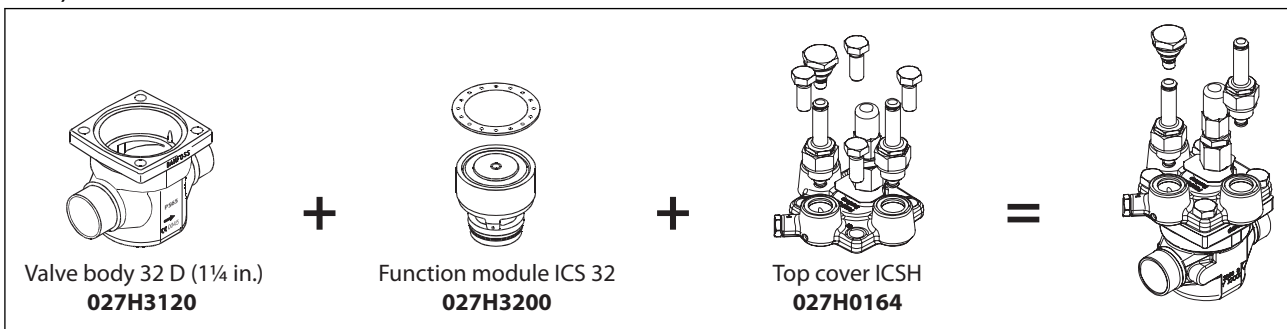



Figure 19: ICV 32 valve body

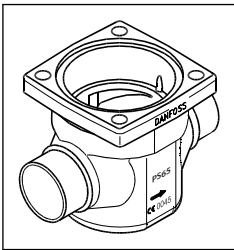

Table 26: ICV 32 valve body w/different connections

Connection	Code Number
32 D (11/4 in.)	027H3120
35 SD (13/8 in. SA)	027H3123
40 D (11/2 in.)	027H3125
32 A (11/4 in.)	027H3121
42 SA (15/8 in.)	027H3127
32 SOC (11/4 in.)	027H3122
42 SD (15/8 in.)	027H3128
40 A (11/2 in.)	027H3126

**D** = Butt-weld DIN

**A** = Butt-weld ANSI

**J** = Butt-weld JIS

**SOC** = Socket weld ANSI

**SD** = Solder DIN

**SA** = Solder ANSI

**FPT** = Female Pipe Thread

Figure 20: ICS 32 function module

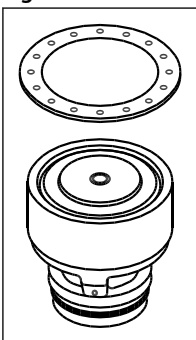

Table 27: ICS 32 function module

Connection	Code Number
ICS 32	027H3200 <sup>(1)</sup>

<sup>(1)</sup> Including gasket and O-rings

Figure 21: ICSH 32 top cover

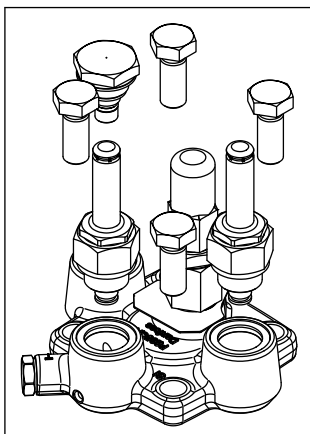

Table 28: ICSH 32 top cover

Description	Code Number
Top cover ICSH	027H0164 <sup>(2)</sup>

<sup>(2)</sup> Including bolts, one blanking plug (A+B) and 2 EVM NC

**Ordering complete factory assembled valve**  
(body, function module and top cover)

Figure 22: Assemble valve

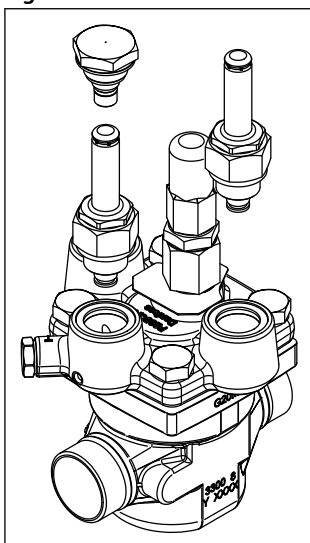

Table 29: ICSH 32 connections

	Available connections							
	32 D (1¼ in.)	40 D (1½ in.)	42 SA (1⅝ in.)	42 SD (1⅝ in.)	35 SD (1⅝ in. SA)	32 A (1¼ in.)	32 SOC (1¼ in.)	40 A (1½ in.)
ICSH 32 <sup>(3)</sup>	027H3309	*	*	*	*	027H3378	027H3377	*

<sup>(3)</sup> Including one blanking plug (A+B) and 2 EVM NC

\* Select from parts programme

## ICSH 40

### Ordering from the parts programme

Figure 23: Example (select from table ICV 40 valve body w/different connections, table ICS 40 function module and ICSH 40 top cover)

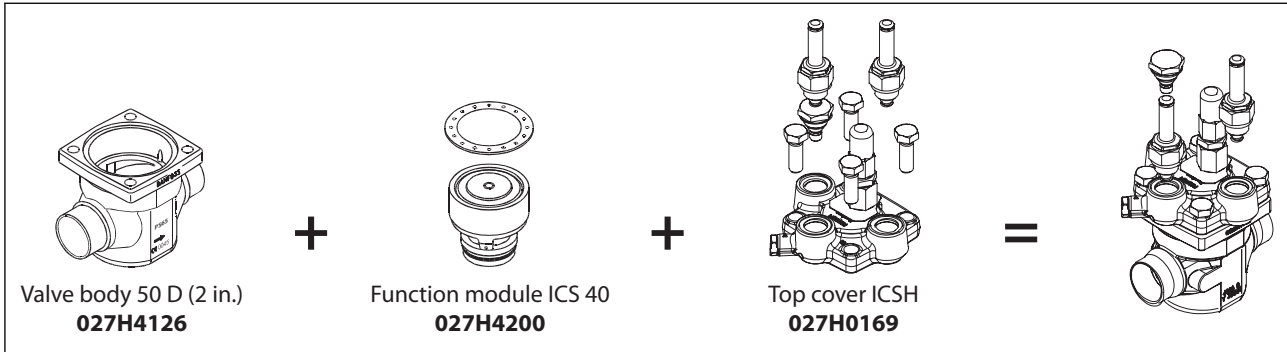

Figure 24: ICV 40 valve body

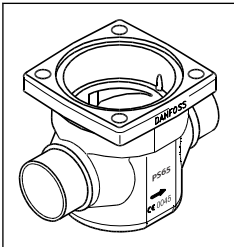

Table 30: ICV 40 valve body w/different connections

Connections	Code Number
40 D (1½ in.)	027H4120
50 D (2 in.)	027H4126
42 SA (1¾ in.)	027H4124
42 SD (1¾ in.)	027H4123
40 A (1½ in.)	027H4121
40 SOC (1½ in.)	027H4122
50 A (2 in.)	027H4127

**D** = Butt-weld DIN

**A** = Butt-weld ANSI

**J** = Butt-weld JIS

**SOC** = Socket weld ANSI

**SD** = Solder DIN

**SA** = Solder ANSI

**FPT** = Female Pipe Thread

Figure 25: ICS 40 function module

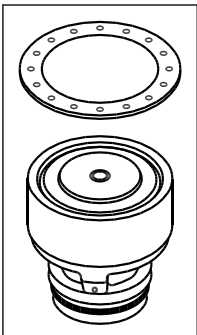

## Pilot operated servo valve, type ICSH 25-80

**Table 31: ICS 40 function module**

Description	Code Number
ICS 40	027H4200 <sup>(1)</sup>

<sup>(1)</sup> Including gasket and O-rings

**Figure 26: ICSH 40 top cover**

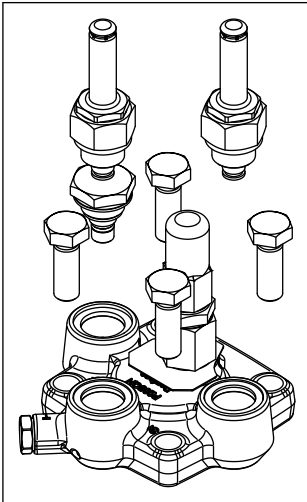
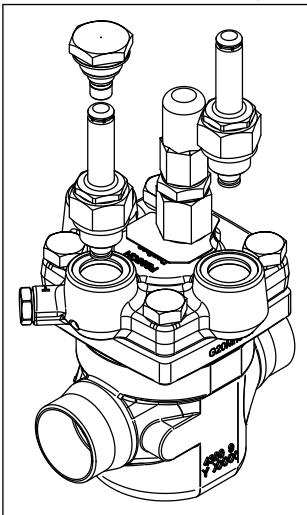

**Table 32: ICSH 40 top cover**

Description	Code Number
Top cover ICSH	027H0169 <sup>(2)</sup>

<sup>(2)</sup> Including bolts, one blanking plug (A+B) and 2 EVM NC

**Figure 27: Valve assembly**



**Table 33: Ordering complete factory assembled valve (body, function module and top cover)**

	Available connections						
	40 D (1½ in.)	50 D (2 in.)	42 SA (1⅝ in.)	42 SD (1⅝ in.)	40 A (1½ in.)	40 SOC (1½ in.)	50 A (2 in.)
ICSH 40 <sup>(3)</sup>	027H4309	*	*	*	027H4308	027H4307	*

<sup>(3)</sup> Including one blanking plug (A+B) and 2 EVM NC

\* Select from parts programme

## ICSH 50

### Ordering from the parts programme

Figure 28: Example (select from below table ICV 50 valve body w/different connections, ICS 50 function module and ICSH 50 top cover)

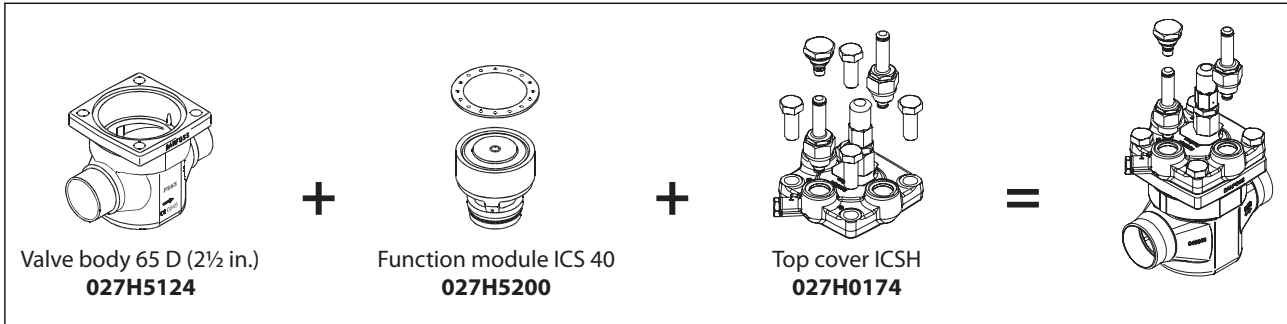

Figure 29: ICV 50 valve body

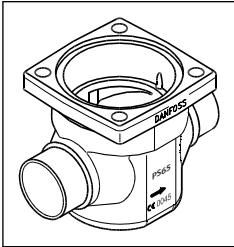

Table 34: ICV 50 valve body w/different connections

Connections	Code Number
50 D (2 in.)	027H5120
50 SOC (2 in.)	027H5122
65 D (2 1/2 in.)	027H5124
65 A (2 1/2 in.)	027H5125
54 SD (2 1/8 in. SA)	027H5123
50 A (2 in.)	027H5121

**D** = Butt-weld DIN

**A** = Butt-weld ANSI

**J** = Butt-weld JIS

**SOC** = Socket weld ANSI

**SD** = Solder DIN

**SA** = Solder ANSI

**FPT** = Female Pipe Thread

Figure 30: ICS 50 function module

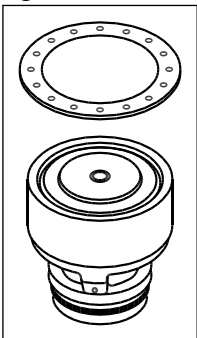

Table 35: ICS 50 function module

Description	Code Number
ICS 50	027H5200 <sup>(1)</sup>

Pilot operated servo valve, type ICSH 25-80

<sup>(1)</sup> Including gasket and O-rings

Figure 31: ICSH 50 top cover

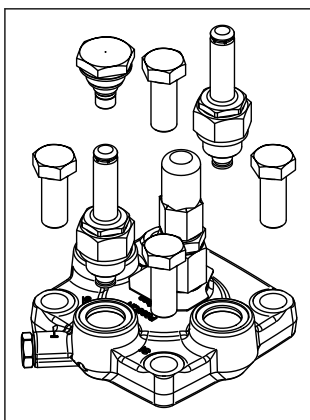

Table 36: ICSH 50 top cover

Description	Code Number
Top cover ICSH	027H0174 <sup>(2)</sup>

<sup>(2)</sup> Including bolts, one blanking plug (A+B) and 2 EVM NC

Figure 32: Valve assembly

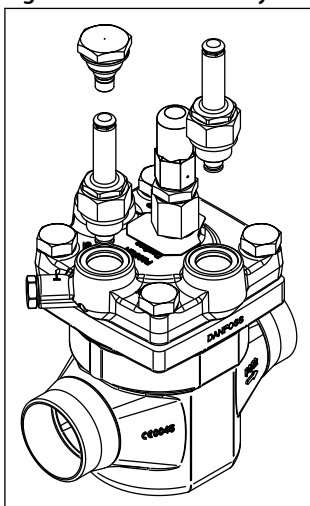

Table 37: Ordering complete factory assembled valve (body, function module and top cover)

	Available connections					
	50 D (2 in.)	65 D (2½ in.)	54 SD (2⅜ in. SA)	65 A (2½ in.)	50 A (2 in.)	50 SOC (2 in.)
ICSH 50 <sup>(3)</sup>	027H5309	*	*	*	027H5308	027H5307

<sup>(3)</sup> Including one blanking plug (A+B) and 2 EVM NC

\* Select from parts programme

## ICSH 65 and ICSH 80

### Ordering from the parts programme

Figure 33: Example (select from table ICV 65 valve body w/different connections, table ICS 65-80 function module and table ICSH 65-80 top cover)

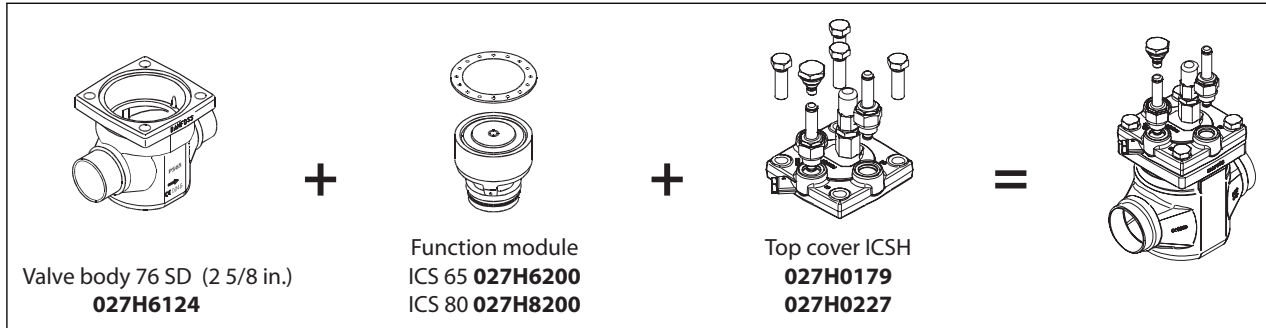

Figure 34: ICV 65 valve body

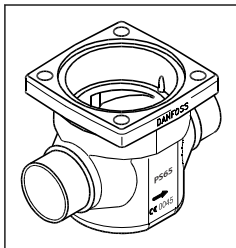

Table 38: ICV 65 valve body w/different connections

Connections	Code Number
65 D (21/2 in.)	027H6120
65 A (21/2 in.)	027H6121
65 J (21/2 in.)	027H6122
80 D (3 in.)	027H6126
80 A (3 in.)	027H6127
67 SA (2 5/8 in.)	027H6125
76 SD (3 in.)	027H6124
65 SOC (21/2 in.)	027H6123

**D** = Butt-weld DIN

**A** = Butt-weld ANSI

**J** = Butt-weld JIS

**SOC** = Socket weld ANSI

**SD** = Solder DIN

**SA** = Solder ANSI

**FPT** = Female Pipe Thread

Figure 35: ICS 65-80 function module

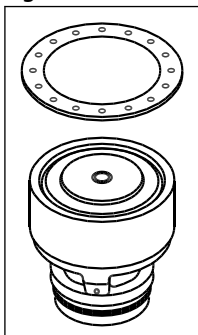

## Pilot operated servo valve, type ICSH 25-80

**Table 39: ICS 65-80 function module**

Description	Code Number
ICS 65	027H6200 <sup>(1)</sup>
ICS 80	027H8200 <sup>(1)</sup>

<sup>(1)</sup> Including gasket and O-rings

**Figure 36: ICSH 65-80 top cover**

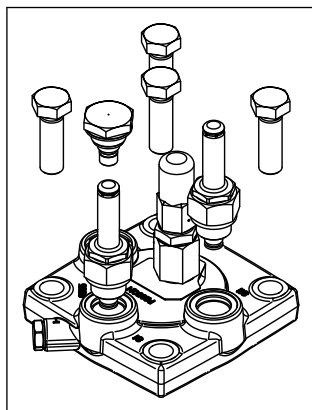
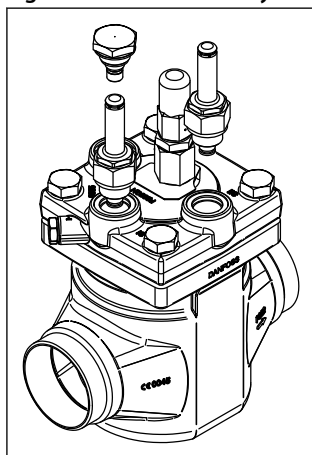

**Table 40: ICSH 65-80 top cover**

Description	Code Number
Top cover ICSH (65)	027H0179 <sup>(2)</sup>
Top cover ICSH (80)	027H0227 <sup>(2)</sup>

<sup>(2)</sup> Including bolts, one blanking plug (A+B) and 2 EVM NC

**Figure 37: Valve assembly**



**Table 41: Ordering complete factory assembled valve (body, function module and top cover)**

	Available connections							
	65 D (2½ in.)	65 A (2½ in.)	65 SOC (2½ in.)	80 D (3 in.)	80 A (3 in.)	67 SA (2⅝ in.)	76 SD (3 in.)	65 J (2½ in.)
ICSH 65 <sup>(3)</sup>	027H6309	027H6311	027H6308	*	*	*	*	*
ICSH 80 <sup>(3)</sup>	*	*	*	027H7302	027H7303	*	*	*

<sup>(3)</sup> Including one blanking plug (A+B) and 2 EVM NC

\* Select from parts programme



## Accessories

### ICV PM flanged valve housings

ICV PM flanged valve housings can replace the PM valves on already installed refrigeration systems.

#### Pressure range

The ICV PM valve housing is designed for a max. working pressure of 28 bar / 406 psig and therefore a suitable replacement for PM valves in the service market. They also offer the same drop-in dimensions as the PM valves.

**Table 42: ICV PM valve housing**

Description	Code no.
ICV 25 PM Valve housing	027H2119 <sup>(1)</sup>
ICV 32 PM Valve housing	027H3129 <sup>(1)</sup>
ICV 40 PM Valve housing	027H4128 <sup>(1)</sup>
ICV 50 PM Valve housing	027H5127 <sup>(2)</sup>
ICV 65 PM Valve housing	027H6128 <sup>(2)</sup>

<sup>(1)</sup> Includes ICV PM valve housing, flange gaskets and flange bolts.

<sup>(2)</sup> Includes ICV PM valve housing, flange gaskets, flange bolts and flange nuts.

Function modules and top covers must be ordered separately (see the section “Ordering”).

**Figure 38: ICV PM flanged valve housing**

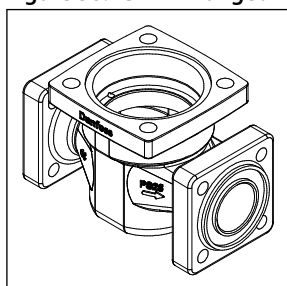

**Figure 39: Function modules and top covers**

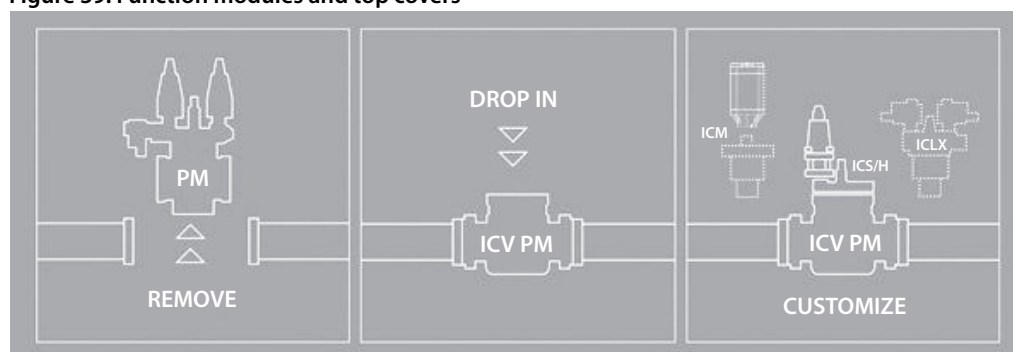

### ICV (H)A4A flanged valve housings

ICV (H)A4A flanged valve housings can replace the (H)A4A valves on already installed refrigeration systems.

#### Pressure range

The ICV (H)A4A valve housing is designed for a max. working pressure of 28 bar g / 406 psig and therefore a suitable replacement for (H)A4A valves in the service market. They also offer the same drop-in dimensions as the (H)A4A valves.

**Table 43: ICV (H)A4A flanged valve housings**

Description	Code no.
ICV 25 (H)A4A Valve housing	027H2304 <sup>(3)</sup>
ICV 32 A4A Valve housing	027H3130 <sup>(3)</sup>
ICV 32 HA4A Valve housing	027H3131 <sup>(3)</sup>

## Pilot operated servo valve, type ICSH 25-80

Description	Code no.
ICV 40 (H)A4A Valve housing	027H4129 <sup>(3)</sup>
ICV 50 (H)A4A Valve housing	027H5128 <sup>(3)</sup>
ICV 65 (H)A4A Valve housing	027H6129 <sup>(3)</sup>

<sup>(3)</sup> Includes ICV (H)A4A valve housing, flange gaskets, flange bolts and flange nuts.

**Figure 40: ICV (H)A4A flanged valve housing**

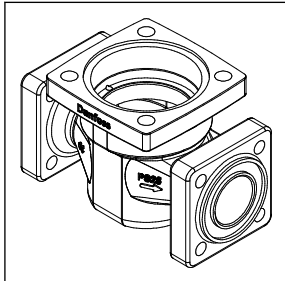

Function modules and top covers must be ordered separately (see the section “**Ordering**”).

**Figure 41: Function modules and top covers**

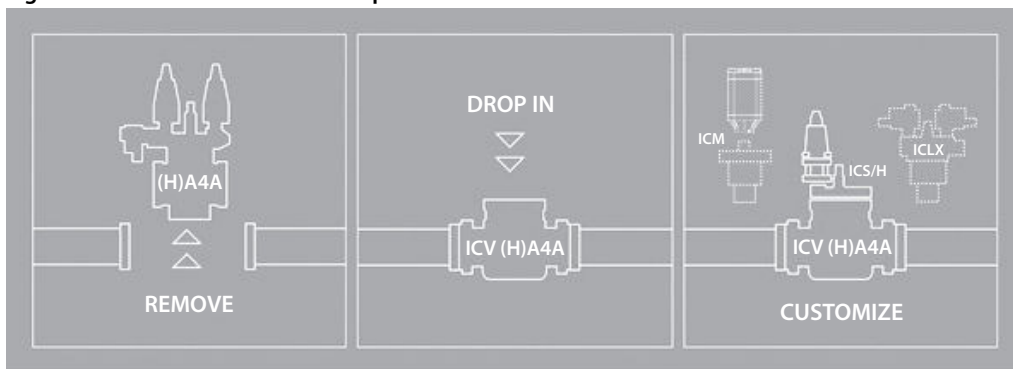

**Figure 42: Plug**

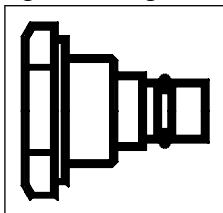

**Table 44: Blanking plug A + B for pilot valves**

Description	Code number
Blanking plug incl. flat gasket	027F1046

## Certificates, declarations, and approvals

The list contains all certificates, declarations, and approvals for this product type. Individual code number may have some or all of these approvals, and certain local approvals may not appear on the list.

Some approvals may change over time. You can check the most current status at [danfoss.com](http://danfoss.com) or contact your local Danfoss representative if you have any questions.

**Table 45: Approvals**

	The ICV valve concept has been designed to fulfill global refrigeration requirements.
---	---

**Table 46: ICSH valves**

ICSH valves		
Nominal bore	DN ≤ 25 (1 in.)	DN 32 - 80 (1¼ - 3 in.)
Classified for	Fluid group I	
Category	Article 4, paragraph 3	II

**Table 47: Certificates and declarations**

File name	Document type	Document topic	Approval authority
033F0685.AK	EU Declaration	EMCD/PED	Danfoss
033F0691.AE	Manufacturers Declaration	RoHS	Danfoss
Д-DK.PA01.B.71727_20	EAC Declaration	PED	EAC
0045 202 1204 Z 00354 19 D 001(00)	Pressure - Safety Certificate	-	TÜV
19.10325.266	Marine - Safety Certificate	-	RMRS

## Online support

Danfoss offers a wide range of support along with our products, including digital product information, software, mobile apps, and expert guidance. See the possibilities below.

### The Danfoss Product Store



The Danfoss Product Store is your one-stop shop for everything product related—no matter where you are in the world or what area of the cooling industry you work in. Get quick access to essential information like product specs, code numbers, technical documentation, certifications, accessories, and more.

Start browsing at [store.danfoss.com](https://store.danfoss.com).

### Find technical documentation



Find the technical documentation you need to get your project up and running. Get direct access to our official collection of data sheets, certificates and declarations, manuals and guides, 3D models and drawings, case stories, brochures, and much more.

Start searching now at [www.danfoss.com/en/service-and-support/documentation](https://www.danfoss.com/en/service-and-support/documentation).

### Danfoss Learning



Danfoss Learning is a free online learning platform. It features courses and materials specifically designed to help engineers, installers, service technicians, and wholesalers better understand the products, applications, industry topics, and trends that will help you do your job better.

Create your Danfoss Learning account for free at [www.danfoss.com/en/service-and-support/learning](https://www.danfoss.com/en/service-and-support/learning).

### Get local information and support



Local Danfoss websites are the main sources for help and information about our company and products. Find product availability, get the latest regional news, or connect with a nearby expert—all in your own language.

Find your local Danfoss website here: [www.danfoss.com/en/choose-region](https://www.danfoss.com/en/choose-region).

### Spare Parts



Get access to the Danfoss spare parts and service kit catalog right from your smartphone. The app contains a wide range of components for air conditioning and refrigeration applications, such as valves, strainers, pressure switches, and sensors.

Download the Spare Parts app for free at [www.danfoss.com/en/service-and-support/downloads](https://www.danfoss.com/en/service-and-support/downloads).

### Coolselector®2 - find the best components for you HVAC/R system



Coolselector®2 makes it easy for engineers, consultants, and designers to find and order the best components for refrigeration and air conditioning systems. Run calculations based on your operating conditions and then choose the best setup for your system design.

Download Coolselector®2 for free at [coolselector.danfoss.com](https://coolselector.danfoss.com).

### Danfoss A/S

Climate Solutions • [danfoss.com](https://danfoss.com) • +45 7488 2222

Any information, including, but not limited to information on selection of product, its application or use, product design, weight, dimensions, capacity or any other technical data in product manuals, catalogues descriptions, advertisements, etc. and whether made available in writing, orally, electronically, online or via download, shall be considered informative, and is only binding if and to the extent, explicit reference is made in a quotation or order confirmation. Danfoss cannot accept any responsibility for possible errors in catalogues, brochures, videos and other material. Danfoss reserves the right to alter its products without notice. This also applies to products ordered but not delivered provided that such alterations can be made without changes to form, fit or function of the product.

All trademarks in this material are property of Danfoss A/S or Danfoss group companies. Danfoss and the Danfoss logo are trademarks of Danfoss A/S. All rights reserved.