

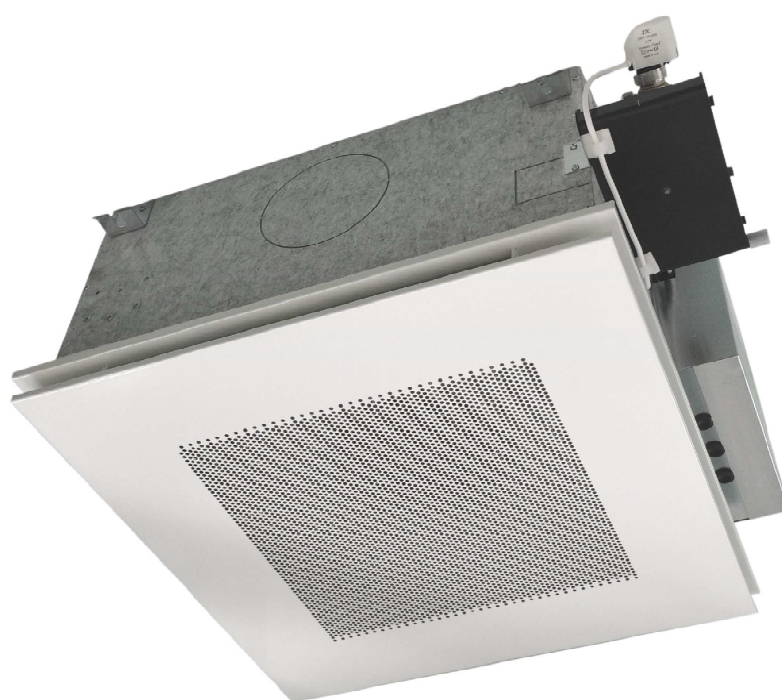

something different

INSTALLATION, USE AND MAINTENANCE MANUAL NEW WATER CASSETTE



BREZZA Series

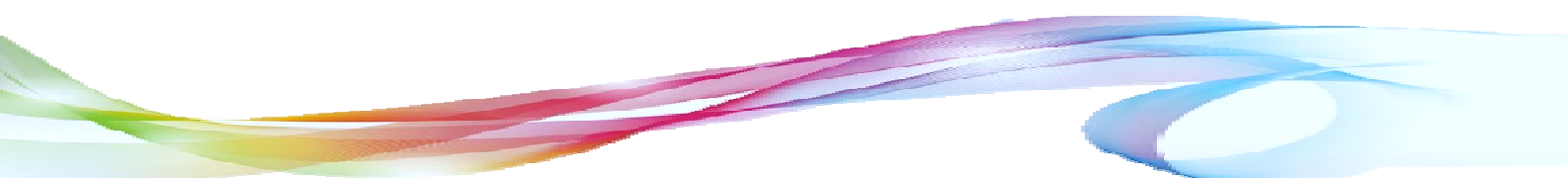

INDEX

<i>Introduction</i>	3
<i>Reception</i>	3
<i>Positioning</i>	3
<i>Installation</i>	4
<i>Water connections</i>	7
<i>Panel installation</i>	10
<i>Ajustment fins</i>	14
<i>Electrical connenctions</i>	15
<i>Maintenance</i>	17
<i>Filter</i>	17
<i>Pump</i>	18
<i>Fan</i>	20
<i>Troubleshooting</i>	21
<i>Waste disposal</i>	22

1-INTRODUCTION

Series units BREZZA are designed for the function of heating, cooling, dehumidification and filtration of residential and tertiary sector (offices, public buildings, or so) with the countertop. Following applications are not permitted:

1. Working outdoors
2. Operations in humid environments or explosive or dusty
3. Operations in corrosive environments, especially for the aluminum fins of the coil.

The use of the machines is not intended for persons (including children) with reduced physical, mental or sensory abilities, or people who have not received adequate information, unless this is done under the supervision of a person responsible for their safety.

The installation and maintenance of the machines are intended to qualified persons (each to his task) and have received necessary instructions. These operations must be done in accordance with safety regulations in force. These standards may, for example, work safety (use of protections for the eyes and hands, ...), plant and electrical installations, pressure vessels, refrigeration equipment, lifting equipment.

The manufacturer / seller is not responsible for damage to persons or property resulting from the failure of requirements in this manual of regular maintenance or use of non-original spare parts or change in the product status with respect to upon receipt. Also in these cases will void the warranty on the product.

This manual must be kept with the machine.

2-RECEPTION

Machines are delivered packed in cardboard boxes. The body of the cassette has a separate package from the front panel. Do not add weight on the packaging and not to stack more boxes than such as are found at the time of delivery. Check the product label, it must have the same code of the order and have no damage to the packaging or the product. In case of non-compliance, immediately contact the manufacturer or the seller and not proceed with the installation. Do not dispose of packaging in the environment; dispose of it in compliance with the rules on waste disposal.

3-POSITIONING

The machine must be positioned in the center of the room or area to be treated. There should be no tall furniture (such as shelves, cabinets, bookcases) under the cassette, which might prevent the accessibility and the correct intake. The distance between the ceiling and the countertop must be at least 15mm greater than the height of the cassette. The cassette is designed to have an effect coanda supply air. This means that the air is moving in the vicinity of the ceiling. For this reason, the ceiling must not hung obstacles (protruding ceiling, or other) to the air flow. The cassette should not be exposed to direct sunlight or heat sources.

Necessary is to provide a gap in the ceiling of the following dimensions (maximum and minimum):

	MAX	MIN
Single cassetta 600x600	605x605	590x590
Double cassetta 1200x600	1205x605	1190x590

4-INSTALLATION

Remove the cardboard packaging and all guards exterior side of polystyrene before installation . Do not remove the drip polystyrene present within the machine. Do not use the front panel to the box before installation . The panel will be applied as a last step .

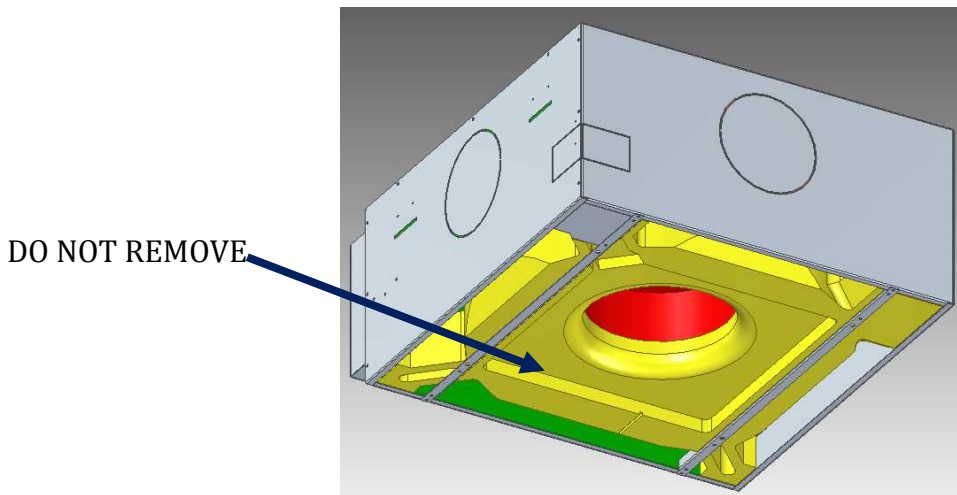

Styrofoam tray

The machine must always be handled by two people and must be grasped only on the proper steps (near the corners of the metal structure), taking care not to damage less resistant parts, in particular the polystyrene tray.

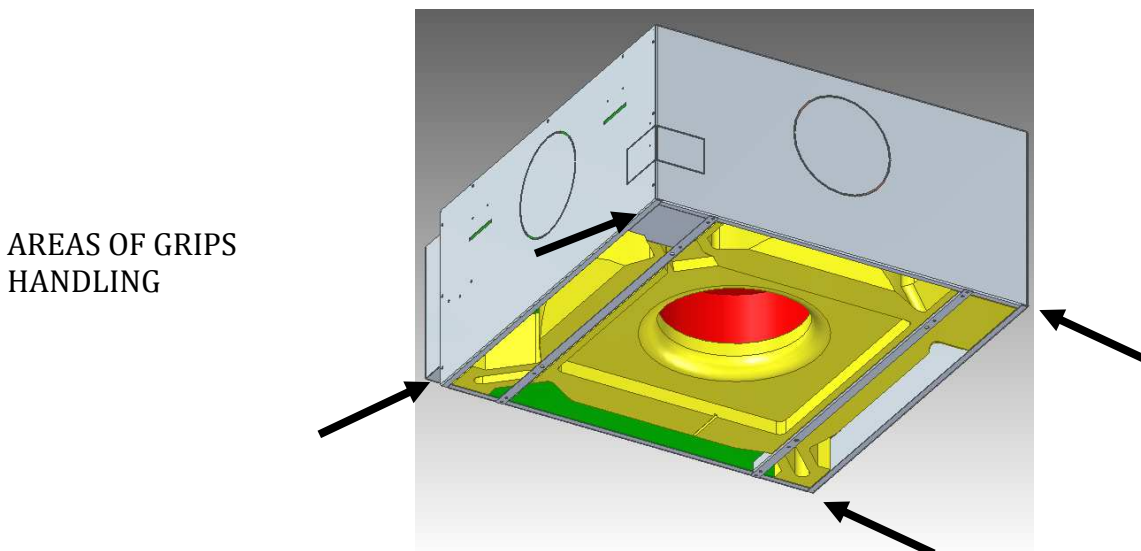

Grip regions

Apply four M8 threaded rods (not supplied) to the ceiling with bolts (not supplied) or other fasteners. Make sure that the components used are rated to support the weight of the machine.

		Single cassette 600x600	Double cassette 1200x600
Installed cassette weight	kg	32	60

The length of the bars depends on the distance between the ceiling and the countertop. The spacing of the bars must comply with the measures of the drawing below and must be central to the opening of the ceiling.

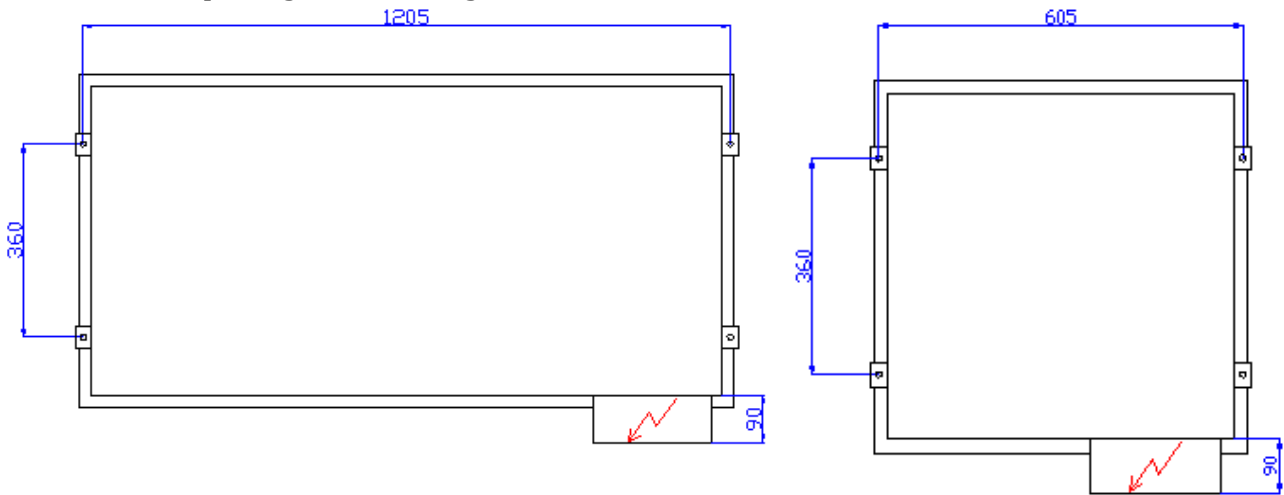

Double cassette 600x600 Single cassette 1200x600

Attach the four brackets supplied with threaded rods, nut, locknut and washer M8 (not supplied).

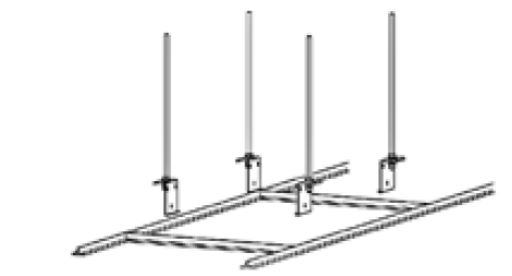
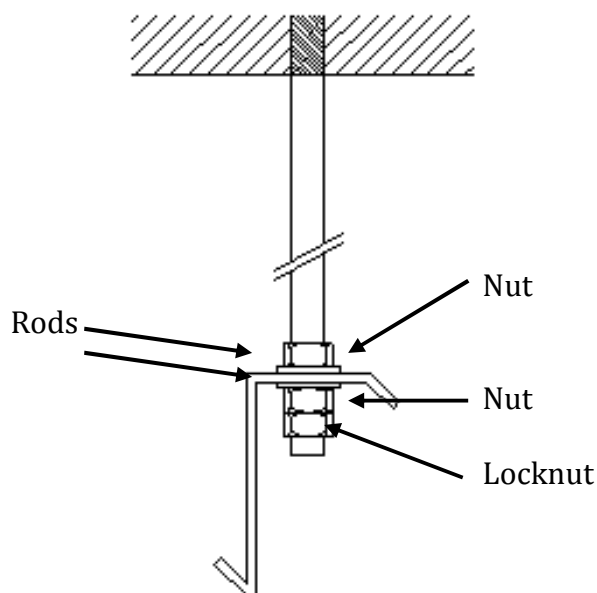

Mounting brackets Ceiling

Lift the box using a suitable lifting device (tackle, hoist, forklift or other) appropriate, that can support the weight of the box. Tilting the machine, with the electrical panel upward, pass it through the opening of the ceiling and position it in a horizontal position.

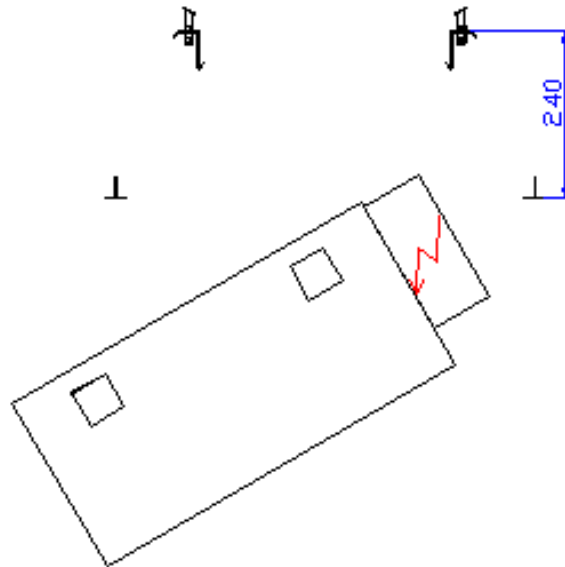

Installation brackets

The hooks of the brackets allow you to temporarily support the machine. Set firmly the brackets to the machine with the screws provided (2 screws per bracket).

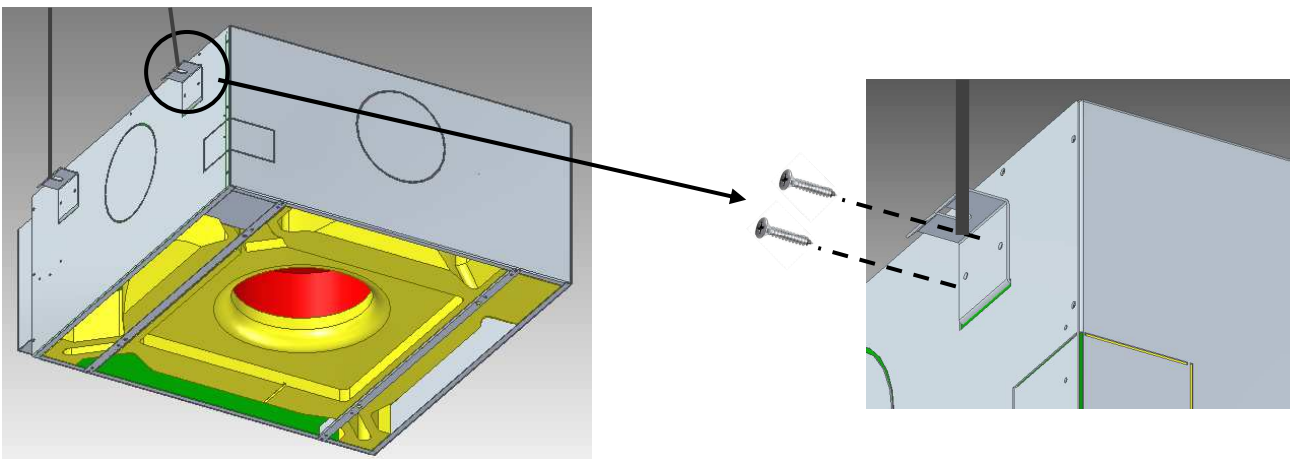

Fixing screws bracket

Make sure the machine is level and that it is aligned to the ceiling. If necessary adjust the height at the nut and locking nuts that hold the threaded rod to the bracket.

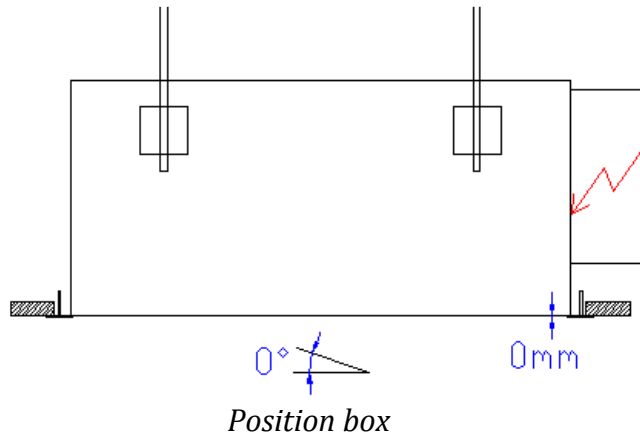

Depending on the type of ceiling and installation site, you can use other procedures, provided they comply with the regulations and do not put at risk the safety of people.

5-WATER CONNECTIONS

The machine is equipped with battery suitable to work with water, possibly mixed with glycol. To avoid the formation of condensation on the surfaces of the cassette during the summer period, in the moments when the fan is not in operation it is recommended to stop the chilled water flow through a motorized valve. All the pipes, in particular those of the chilled water, must be insulated to prevent dripping of condensation. For ease of maintenance, it is



advisable to provide for manual ball valves, in order to exclude the machine from the plant.

During connection of the pipes, not to twist the coil tubes and valves, it is recommended to use key and second. The valves can be pre-installed or supplied in the kit (to be assembled by the installer). In any case, take care to observe the information concerning the entry and exit of water.

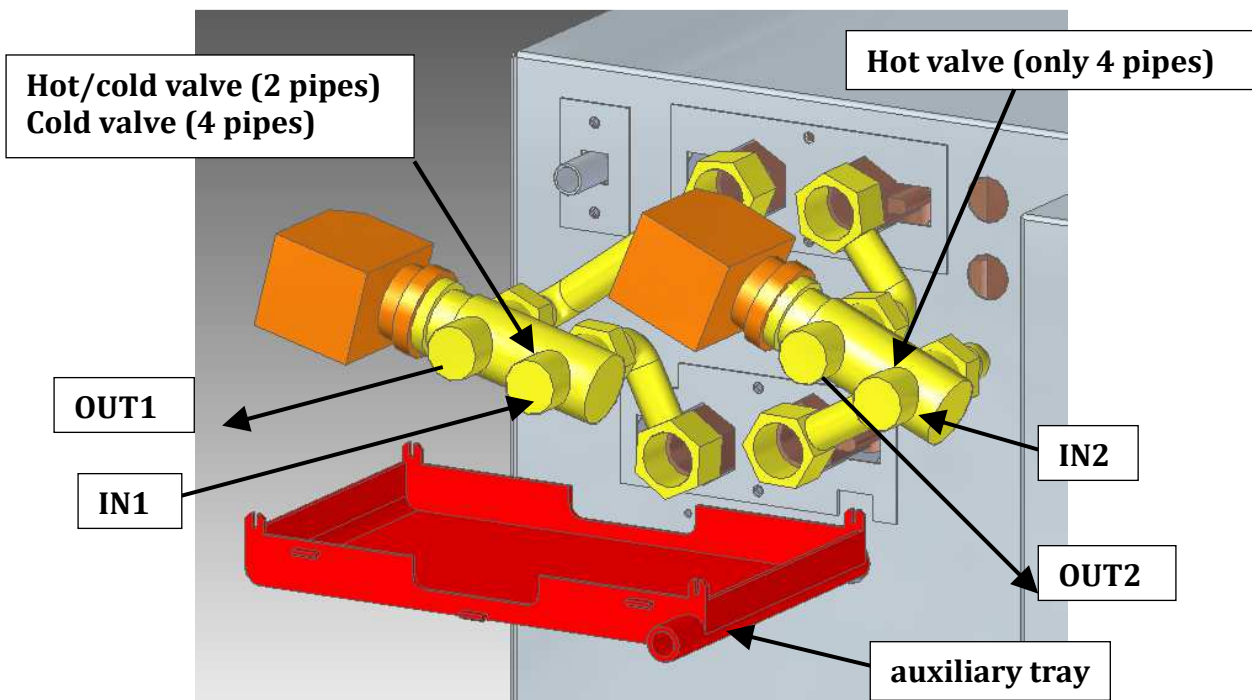

Valves group and auxiliary tray (single cassette 600x600)

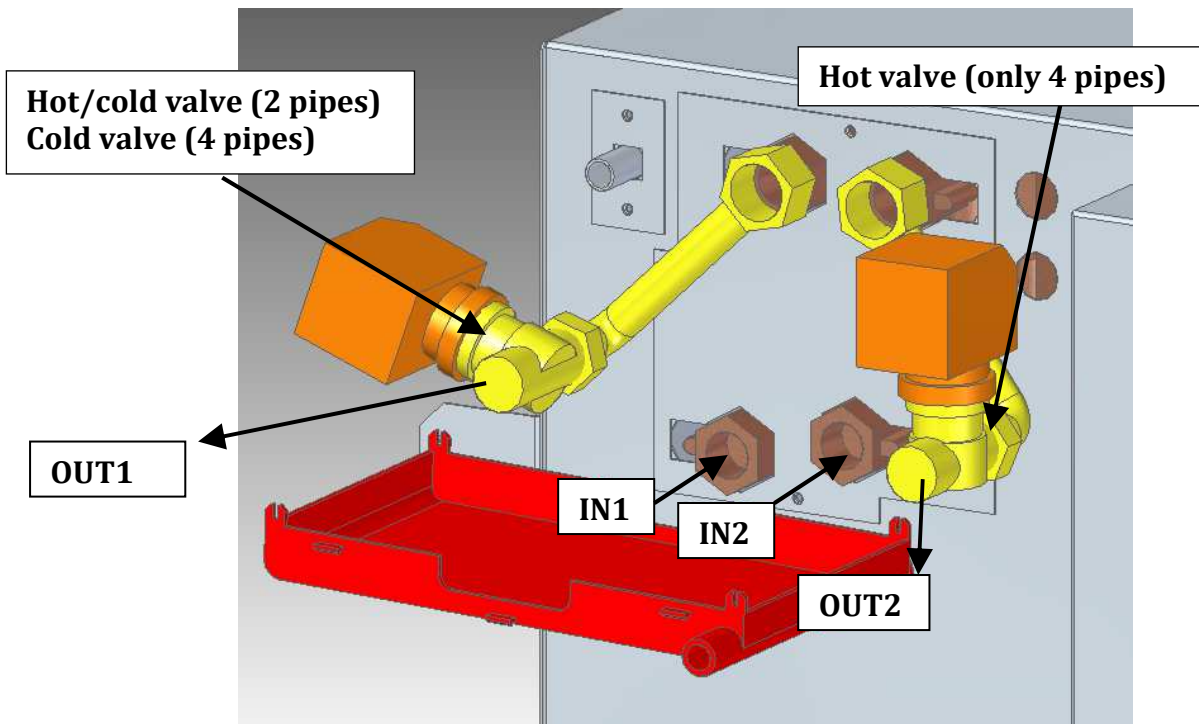

IN1 / OUT1 : input / output for 2-pipe systems or cold battery (for 4-pipe systems)
IN2 / OUT2 : Input / output hot battery (only for 4-pipe systems)

To fix the drain pan, you must first fix the side bracket using two self-tapping screws, then fix the pan with two self-tapping screws and silicone to the edge between the tray and the side of the box.

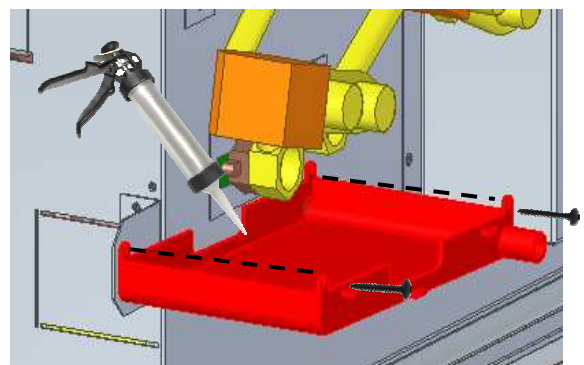
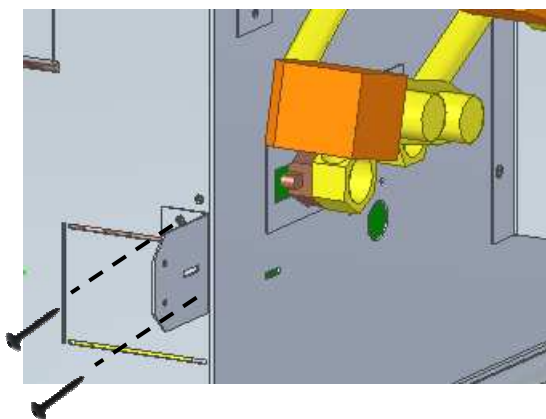

Installing auxiliary tray

The cassettes have two double 1200x600 kit valves, one for the right battery and one for the left battery. The two valves kit must be connected in parallel, the purpose is provided a kit consisting of hoses and TEE brass.

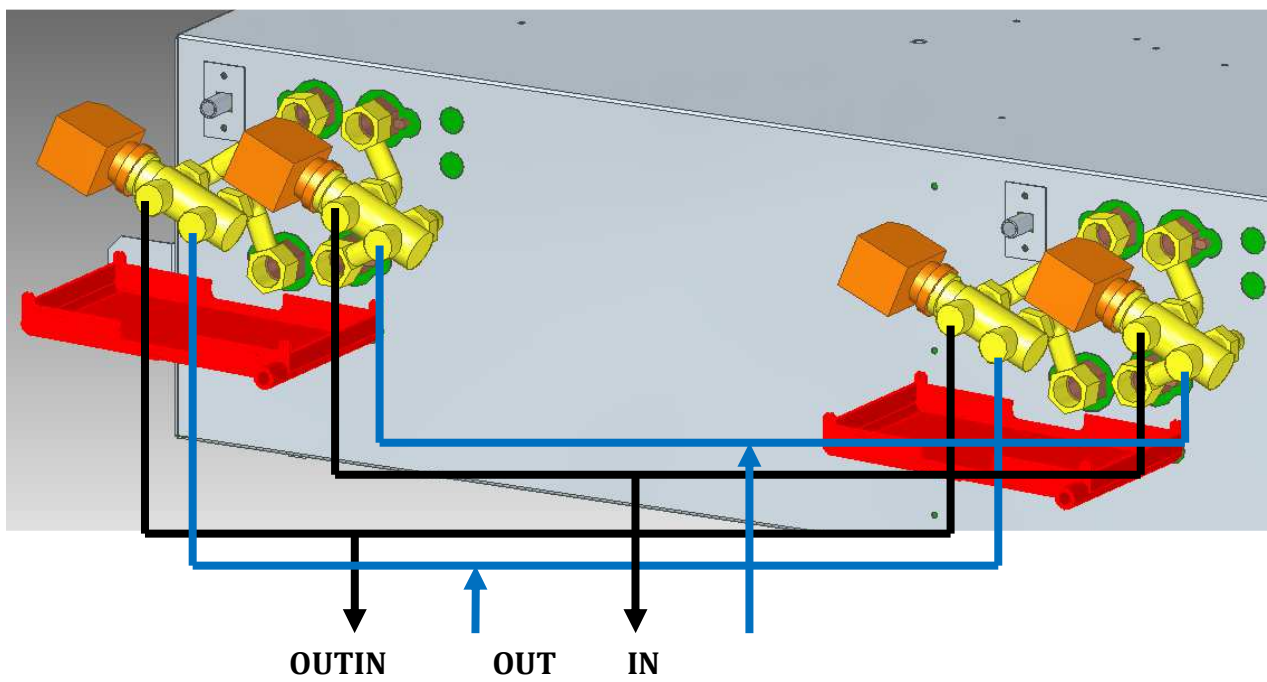
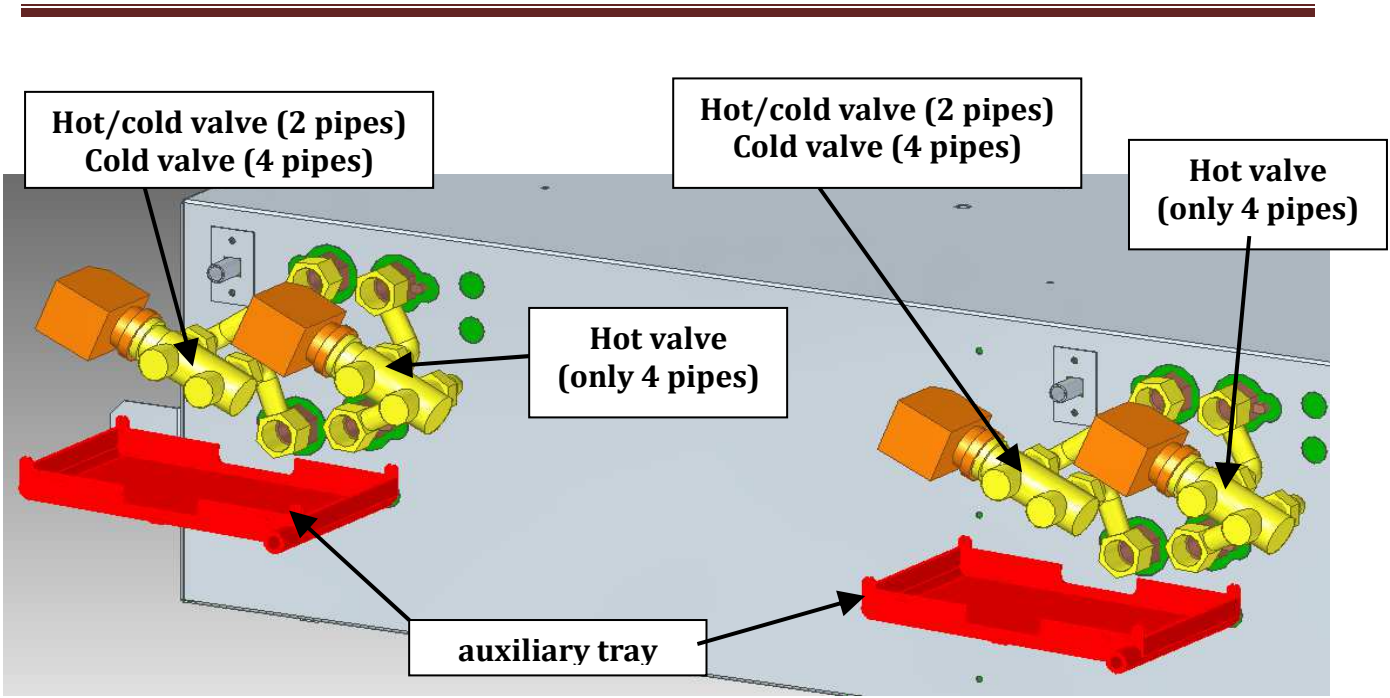

Valves group and auxiliary tray (Single cassette 1200x600)

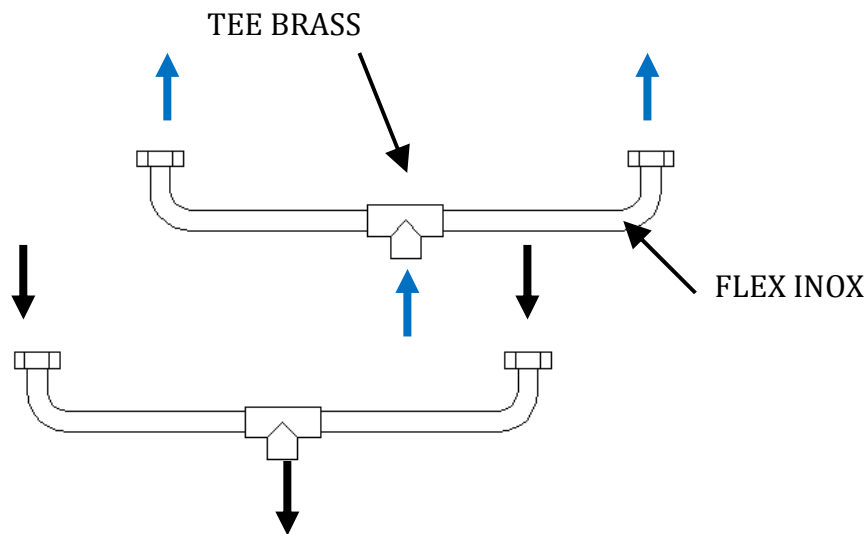

Accessory for flexible double cassette 1200x600

After the installation is complete and you load the hydraulic system, it is necessary to vent the battery through the appropriate needle valve. Repeat breather after operation of the pump, as long as there is the certainty that you have deleted all the bubbles.

Connect the condensate drain connection to an exhaust pipe of internal diameter 12mm. The tube must have a constant slope of at least 2° downwards. The maximum Kerb from the pump is 650mm. The individual cassettes are equipped with only one condensate discharge; double ones have two drains condensate.

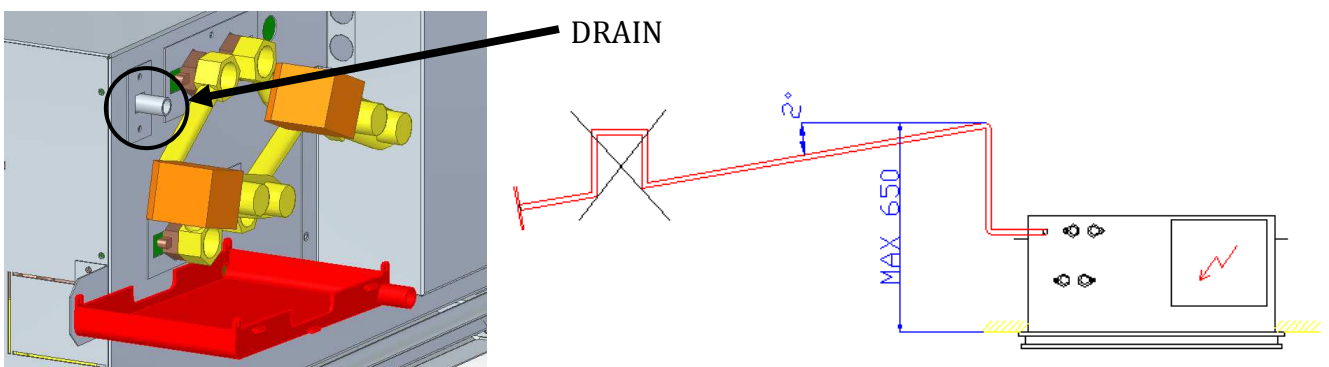

Drain

6-PANEL INSTALLATION

To facilitate the installation of the panel, it is advisable to remove the front panel drilled. To do this, unscrew the two screws M4x10 that constitute the panel hinges and release the panel from the magnets and the safety hook.

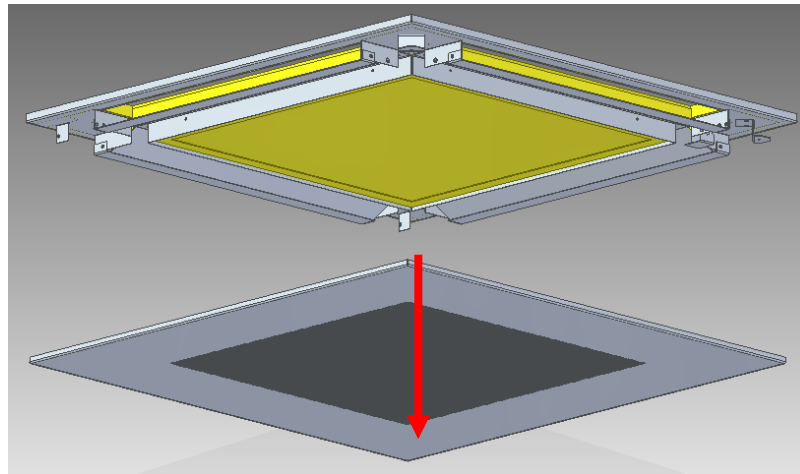
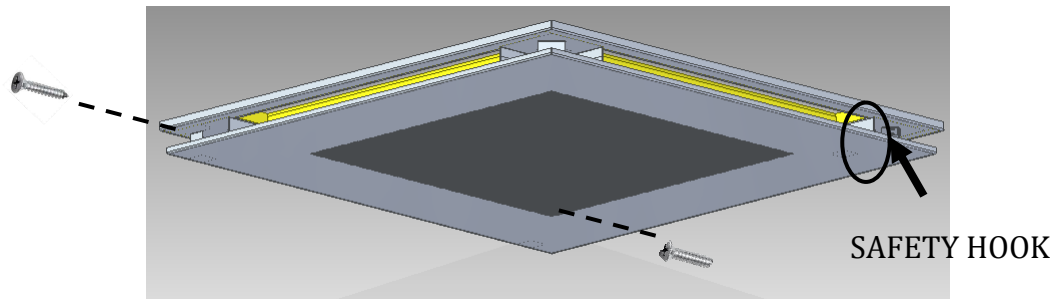

Remove the front panel

Also removes the filter, pulling gently to release it from the magnets.

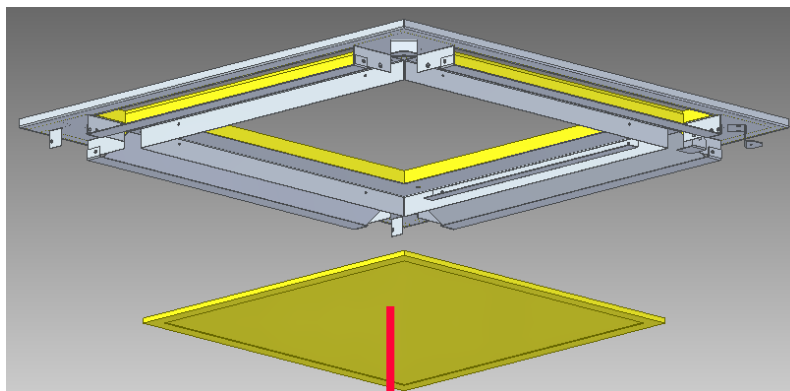

Filter remove

Screw for a length of between 5 and 10mm, two of the four screws M4x20 supplied, threaded inserts in the bars of the cassette. These two screws must be positioned as in the figure below.

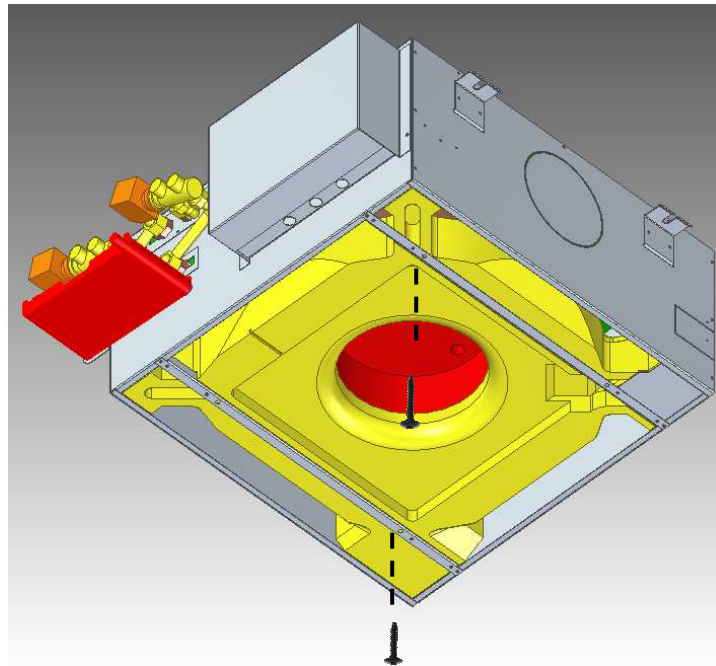

Fixing first two screws

Apply the front panel, by passing the head of the two M4x20 screws through the two holes diameter 11mm.

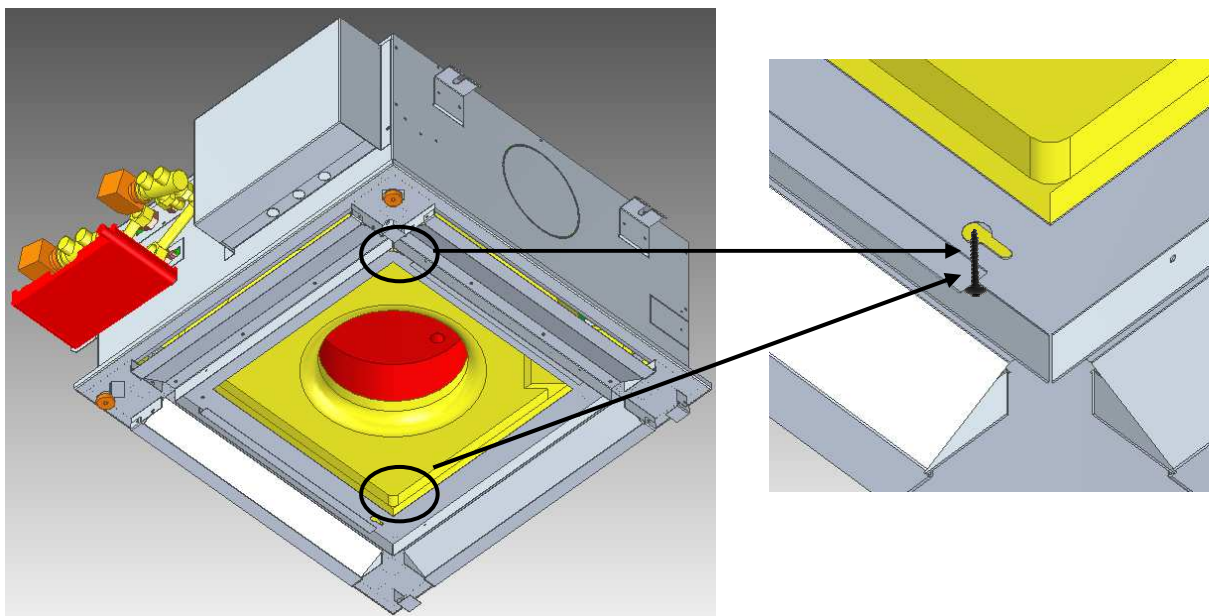

Frontal panel apply

Slide the side panel, until the stems of the two screws touch the end of the slot.

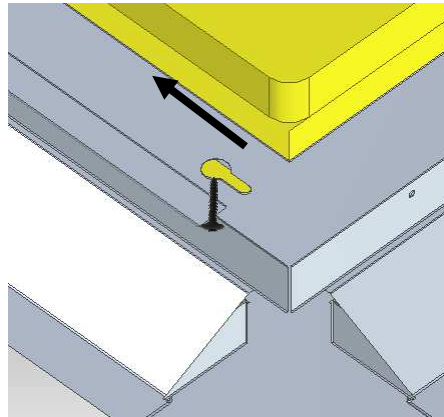

Frontal panel apply

Now fasten the other two screws M4x20 and tighten top two screws.

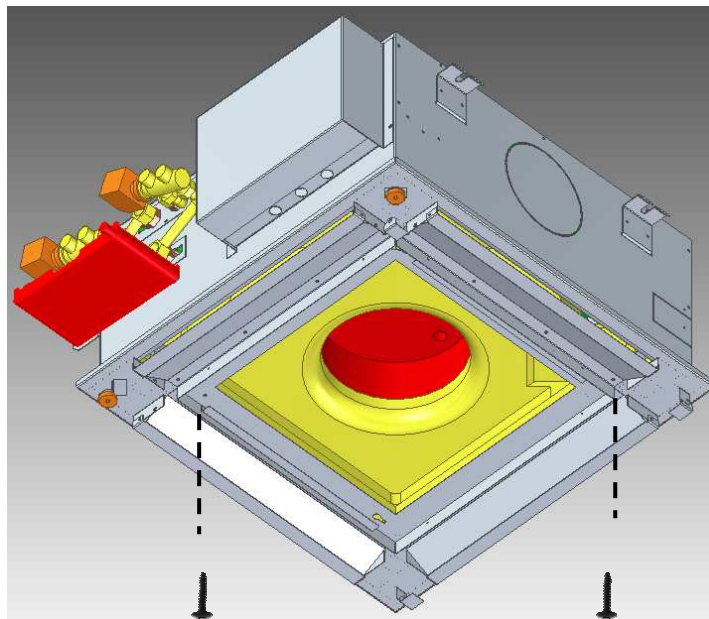

Fixing last two screws

Retracing previous operations on the contrary, apply the filter, attach the hinges of the front panel with the two screws M4x10, secure the safety hook and hook the front panel with the magnets.

7-ADJUSTMENT FINS

The panel can be provided with fixed fins with air throw horizontal (Coanda effect) or of fins manually adjustable in position with air throw horizontal, vertical or intermediate position. The type of panel is easily recognized by observing the presents or less of rectangular slots for the vertical air flow.

ONLY HORIZONTAL

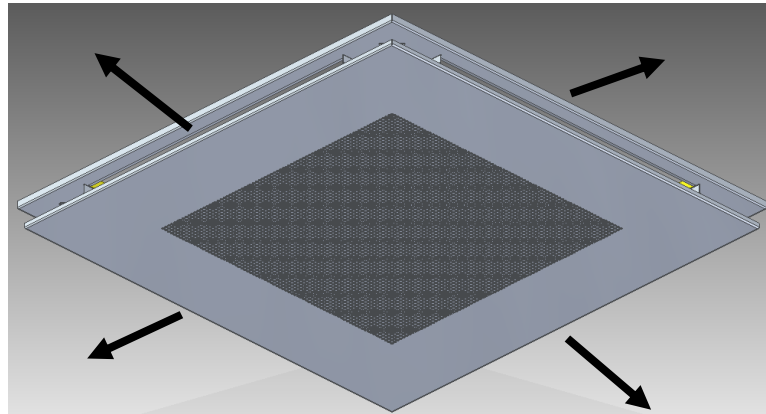

Panel fixed fins

HORIZONTAL

VERTICAL

RECTANGULAR SLOT

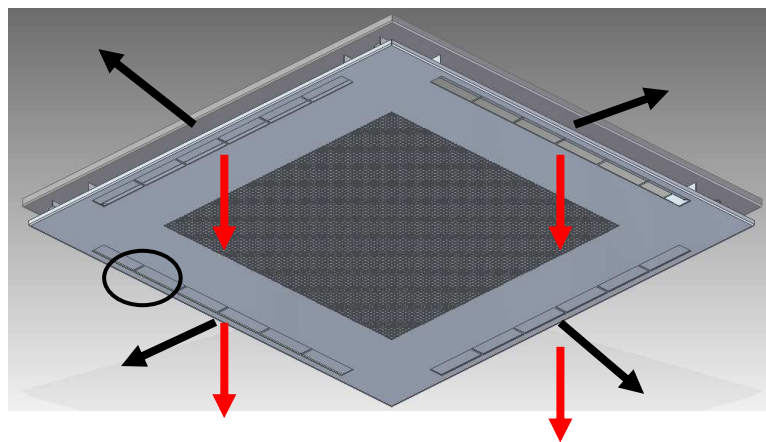

Panel lugs

To adjust the position of the flaps, press lightly with the fingers of the hand, by rotating about the pins.

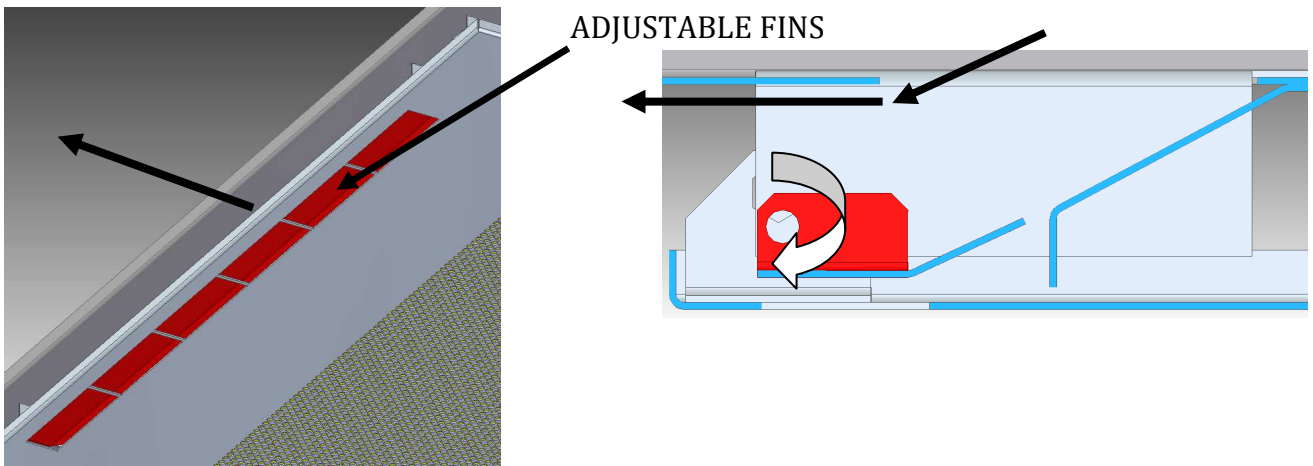

Fins position horizontal flow

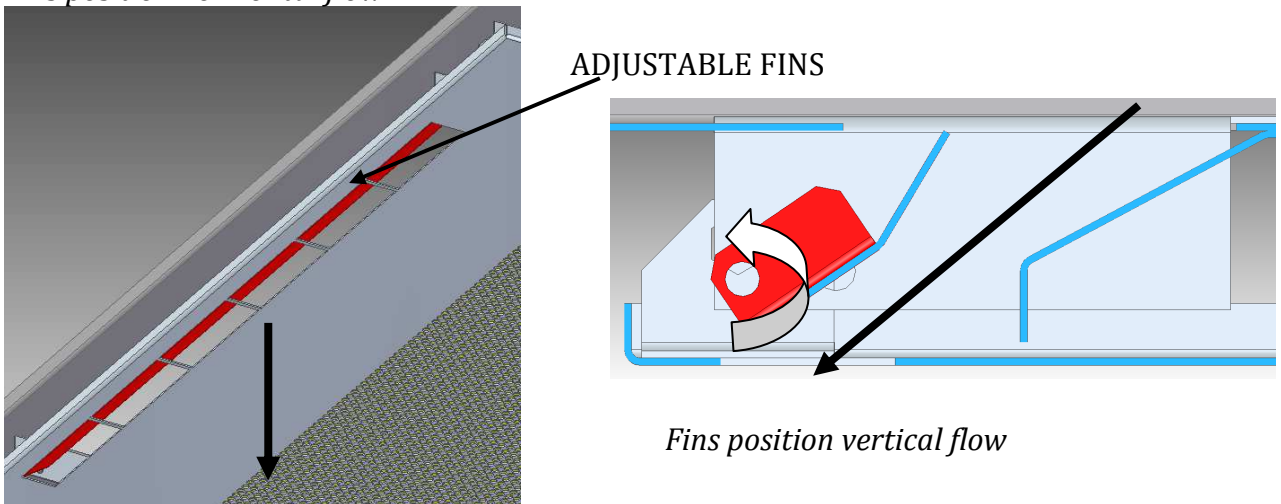

Fins position vertical flow

8-ELECTRICAL CONNECTIONS

Provide a manual disconnecter near the machine to be able to exclude from the power line during maintenance operations.

Provide a fuse or circuit breaker to protect the machine.

The power cables must be dimensioned taking into account the absorption maximum of the machine, labeled and in the technical manual, but not less than 0,75mmq.

Check that the voltage and frequency of the power supply is 230V - 50Hz.

Before attempting any electrical work on the machine, make sure that the main power supply is switched off and that it can not be accidentally inserted.

To remove the cover of the electrical panel, unscrew the two screws on the sides of the lid. Then lift slightly and remove the cover.

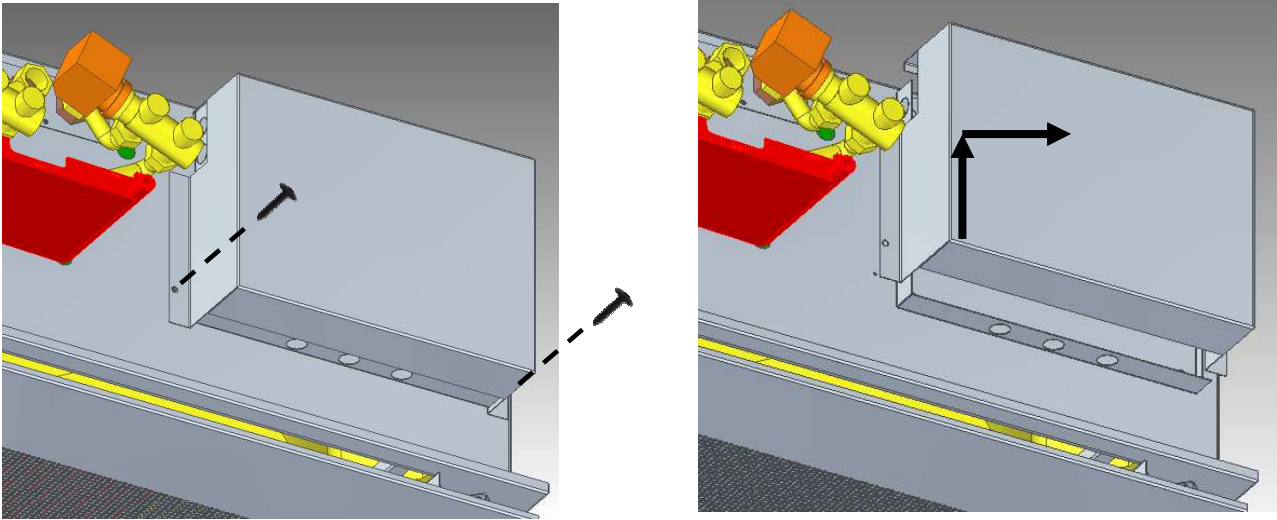

Removing the electrical panel cover

To access with the cables inside the enclosure, use the cable glands at the bottom of the picture.

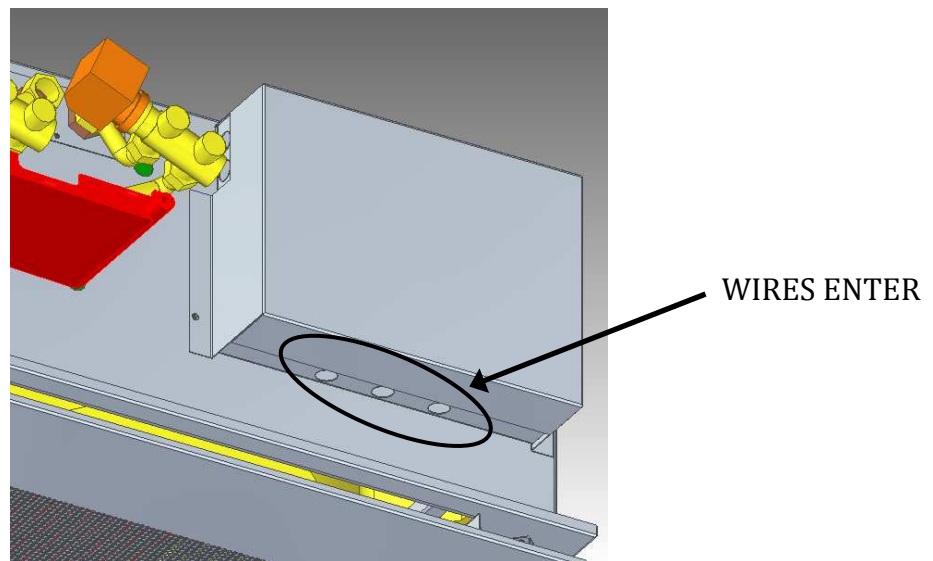

Grommets input in the control cabinet

Before installing electricity, see specific circuit diagram of the unit supplied with the machine. After completing the electrical installation, replace the electrical panel cover and secure it with the two screws.

9-MAINTENANCE

The maintenance of the machine can only be done by qualified and trained.

Before performing any maintenance on the machine, make sure that the main power supply is switched off and that it can not be accidentally inserted. Make sure the motor is stopped before opening the cassette cover.

The motor, the battery and the drain pump does not require regular maintenance. The filter instead requires periodic cleaning.

9.1-Filter

The filter must be cleaned periodically, every 6 months or more often if the environment is dusty. It can be cleaned with a vacuum cleaner or slightly beaten. To access the filter pull down gently on the front panel to release the magnet fixing.

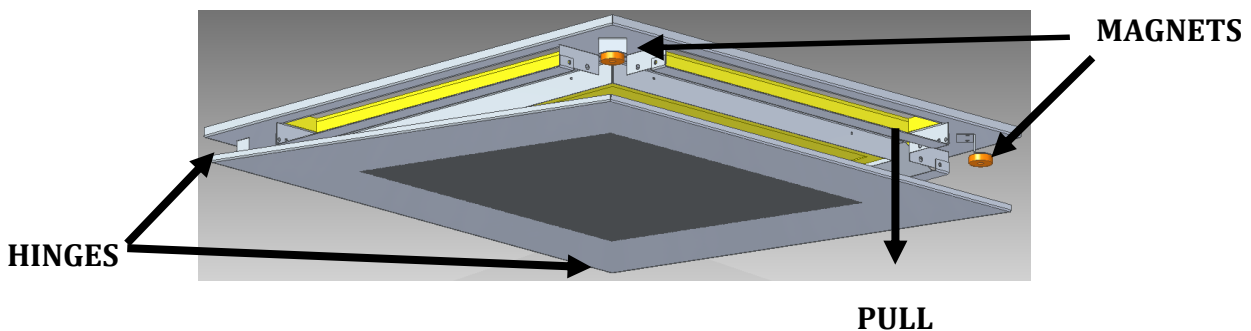

Panel opening

Unhook the safety latch and open the panel.

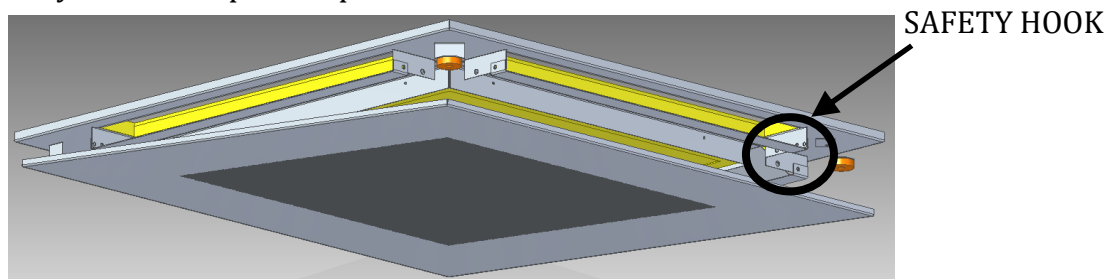

Safety hook

Pull down gently filter to disengage from the magnets.

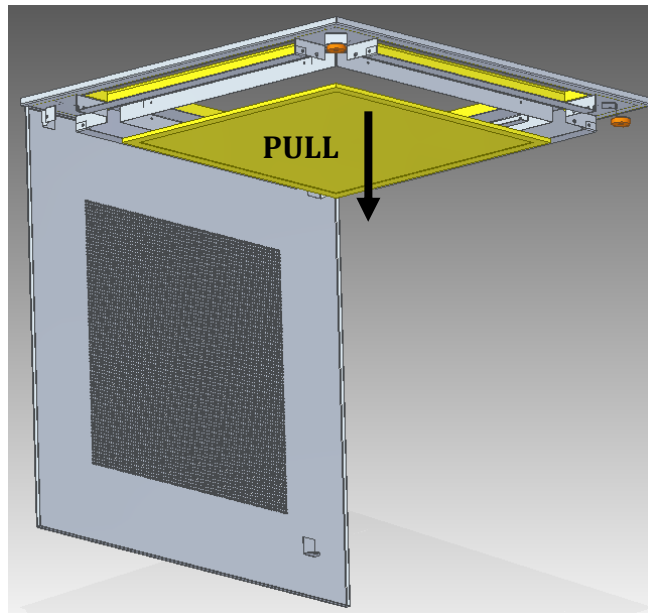

Filter removing

9.2-Pump

To gain access to internal components (pump, fan), you must first remove the front panel. To do this, follow the steps in reverse order in paragraph 5.

Then you must remove the pan polystyrene. First, remove the four screws that secure the cross bars and remove the bars.

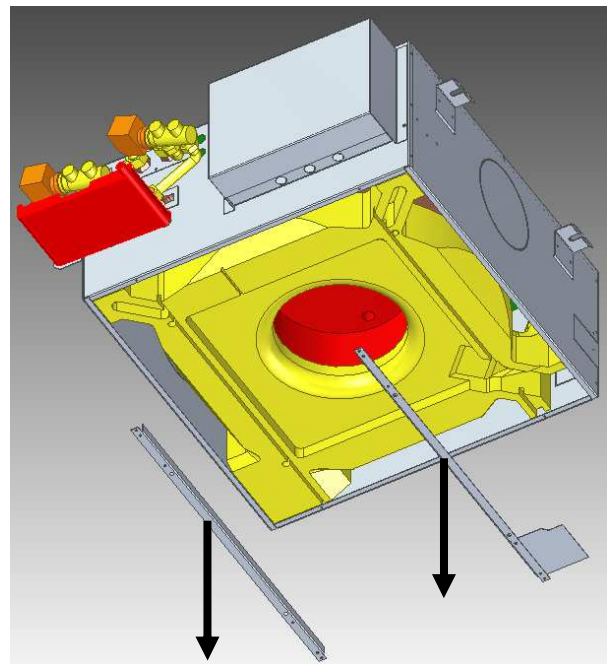
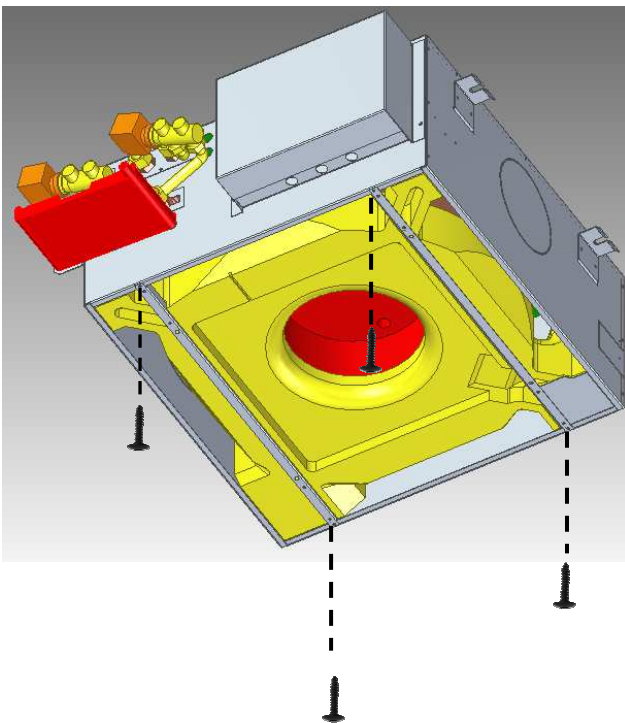

Remove pan support bars

Remove the polystyrene pan, pulling it gently to prevent damage. Be careful not to spill the bowl because inside the tank water may be present.

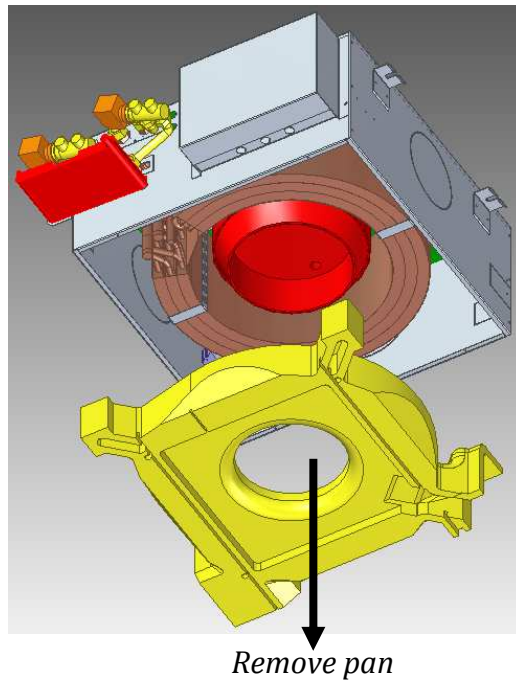

To remove the pump, release the connector from its support, applying pressure with your fingers as shown by the arrows. Then unscrew the two screws circled in the figure.

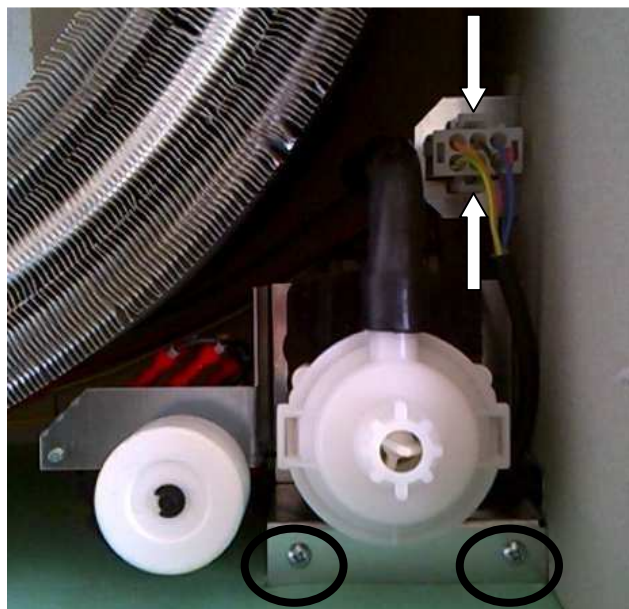

Removing pump

Removing the assembly pump and disconnect the rubber tube, so that the check valve remains integral with the pump unit, which looks like the image below.

CHECK VALVE

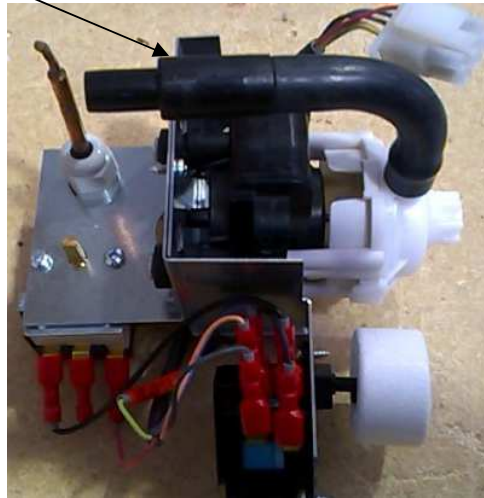

Pump Assembly

To reassemble the pump, run contrary to the previous steps.

9.3-Fan

To remove the fan, you must first remove the front panel and the tray of polystyrene as described in paragraph 8.2.

Disconnect the cable or cables of the fan from the terminals of the electrical panel. Unscrew the four screws M6x10 hex head securing the engine support bracket to the bottom of the box.

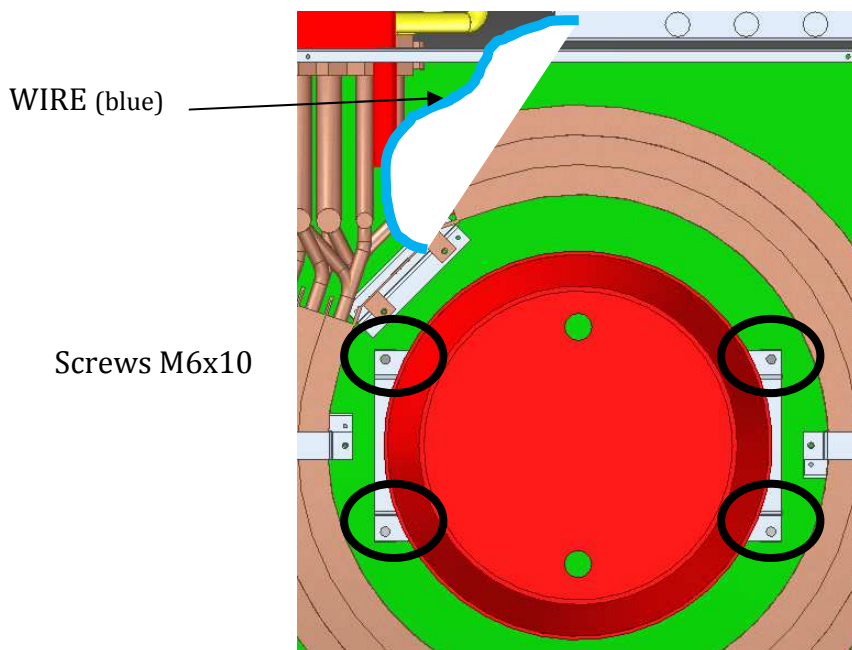

Screws fastening bracket fan

Remove the fan-metal bracket from the box, pulling the cable through the cable guides in the cassette. Unscrew the four screws M4x10 that secure the fan to the bracket, pulling the cable from the cable guides of the bracket.

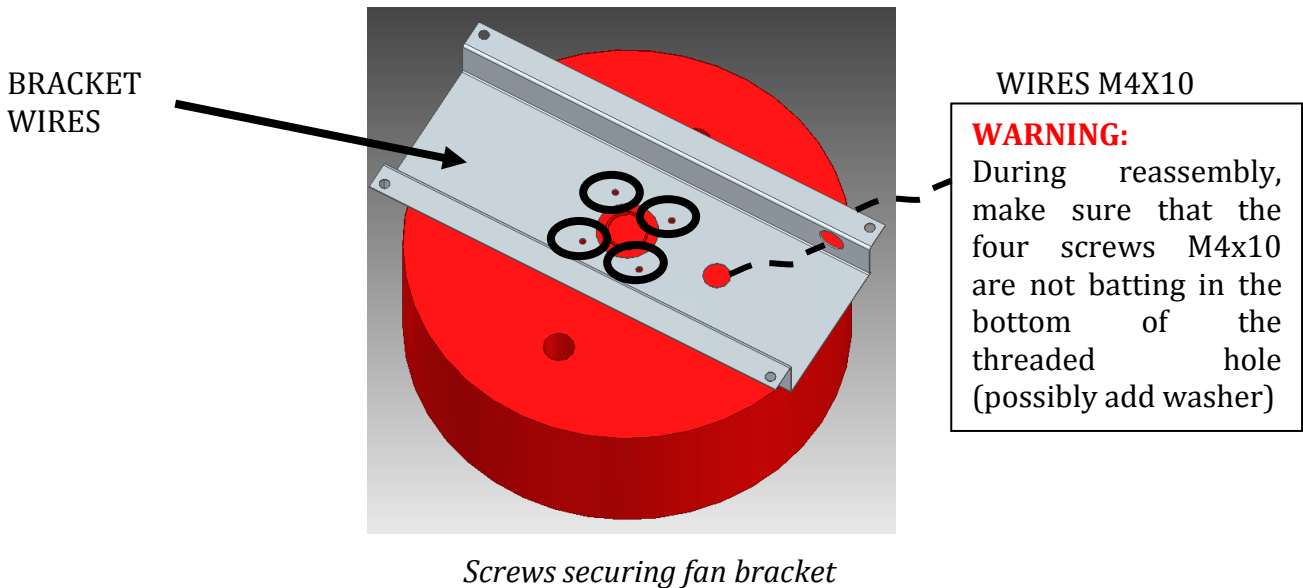

After replacing the fan, reassemble all components performing the same operations in reverse order.

10-TROUBLESHOOTING

Fault	Possible fault	Remedy
The fan does not turn	There is no current The thermostat is damaged The cables are not connected Capacitor broken	Check the circuit breaker / fuse Check if there is power to the terminals of the fan (and / or 0-10V signal for EC) Monitor the implementation of all electrical connections within the scheme Replace the capacitor (AC motor)
Insufficient air flow	Dirty filter Selected speed low	Clean or replace the filter Select a higher speed (max or med)
Noisy fan	Damaged fan Fan loose	Visually check that the fan is intact Check that the fan is fixed firmly to the bottom of the box
In summer comes out hot air or cold air out in the winter	Selected speed high Water too hot Water flow low Valve closed Pump route	Select a velocity lower (min or med) Check that the incoming water is less than 10 ° C in summer or above 40 ° C in winter. Check that the dT between water input and output is at most 7K Check that all manual valves are open to interception The float has closed the valve for pump alarm

Condensation on the panel	Valve Actuator broken	Check that the actuator has opened the valve
	Air in the battery	Vent drums and pipes
	Water too cold	Raise the water inlet temperature
	Speed too low	Increase the speed of the fan (med or max)
Dripping from the pan	Condensate drain clogged	Control the outflow of the exhaust pipe
	Pan counterslope	Check that the tray is level or tilted slightly towards the drain
	Float broken	The float switches the pump
	Pump route	The pump does not work or is dirty (clogged)
	Check valve stuck	The check valve prevents the passage of water
	Water pipes are not insulated	Insulate all chilled water pipes
	Defective seals	Check seals of hose connections
	Dirty pan	Clean the pan to allow the normal flow of condensate

11-WASTE DISPOSAL

At the end of his service, the unit must be disposed of in compliance with local regulations on waste disposal. The main materials present are: copper, aluminum, steel, polystyrene, plastic.

NOTES:

Aertesi srl reserves the right to introduce at any time whatever modifications deemed necessary for improving the product with possible modification of the relevant technical data



Aertesi srl Unipersonale

viale della tecnica, 6a
35026 Conselve (PD) ITALY
t. +39.049.9501109
f. +39.049.9500823

www.aertesi.com
info@aertesi.com