

Data Sheet

Liquid level switch
Type **LLS 4000 and LLS 4000U**

Compact, cost-efficient, and reliable switch for liquid level measurements



The LLS 4000/4000U liquid level switch is designed to detect the state (gas or liquid) of the refrigerant in front of the sensing head, while installed in a wide range of refrigeration applications.

The LLS level switch comes in 2 variants, LLS 4000 and LLS 4000U. They are identical except for the connector thread interface to the system. The LLS 4000 is provided with G 3/4" thread, while the LLS 4000U is provided with NPT 3/4" thread.

The LLS 4000/4000U liquid level switch is based on the proven reflectometry measuring technology (microwave level measurement) adapted specifically for the new LLS 4000/4000U switch.

LLS 4000/4000U liquid level switches can be used to control the liquid level of many different refrigerants in vessels, accumulators, receivers, standpipes, etc. The switches are normally installed in a pair of two, controlling the upper liquid level and the lower liquid level.

The level switch includes a relay that switches by change in refrigerant state. The on site configuration of the LLS allows the normally open/closed relay setting depending on the desired correlation.

For SIL applications a SIL2 version is available with blocked configuration (not configurable).

All configuration and readings from the LLS switch are performed through Bluetooth and a downloadable special Danfoss app.

Features

- Plug and play liquid level switch
- Easy installation and minimum or no need for configuration
- SIL design with redundancy on microprocessor and relay
- Convenient communication with all units via Bluetooth and a Danfoss app
- SIL2 compliant version
- Two commonly used connection variants
- Maintenance free
- Replacement of electronic part without removing mechanical part (not applicable for SIL2 devices)
- Applicable for ammonia and commonly used H(C)FCs
- Applicable for R1234ze(E) with POE oils (miscible) or oil free systems
- Applicable for refrigerant oils in Ammonia and H(C)FC systems with a refrigerant gas temperature up to max. 80 °C
- For other medias and mixed medias, please contact Danfoss
- Well proven reflectometry measuring principle
- Conforms to: Telecommunications Directive RED 2014/53 EU. Low voltage directive 2014/35/EU. EMC directive 2014/30/EU. ROHS 2011/65/EU
- Approvals: SIL2, FCC, IC, EAC, UA, CMIIT, ANATEL, NBTC CRN

Applications

To control if a liquid level is within predefined allowed limits, two LLS 4000 are installed in an upper and a lower limit position respectively. By this setup the liquid level is between the two level switches and the lower switch will sense liquid, while the upper will sense gas.

In case the liquid level moves outside the limits, one of the switches will sense opposite and switch the built-in relay. This relay switch function should be used for alarm settings. This is made easy when connected to the system PLC.

Figure 1: LLS locations

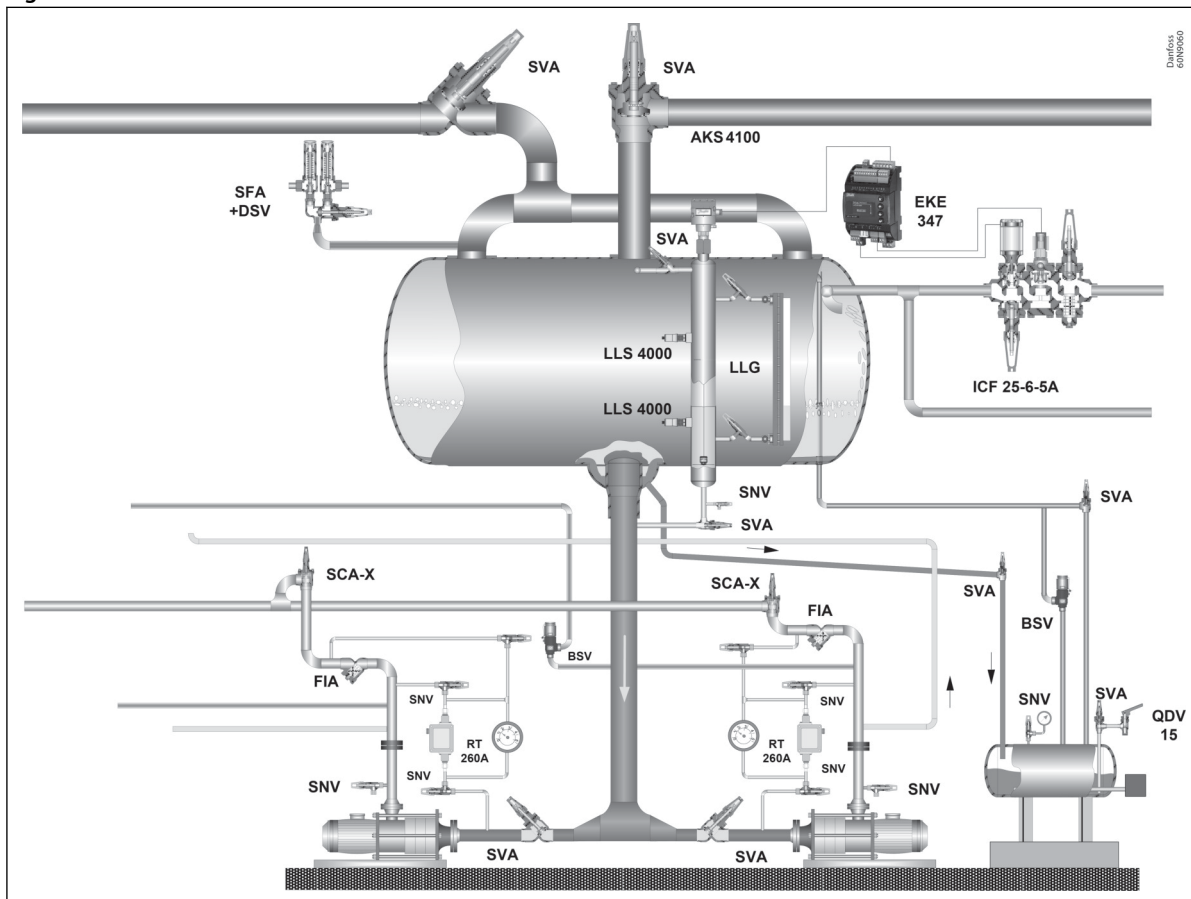

NOTE:

The LLS can be used wherever liquid levels of selected refrigerants and refrigerant oils must be controlled.

Figure 2: LLS orientation

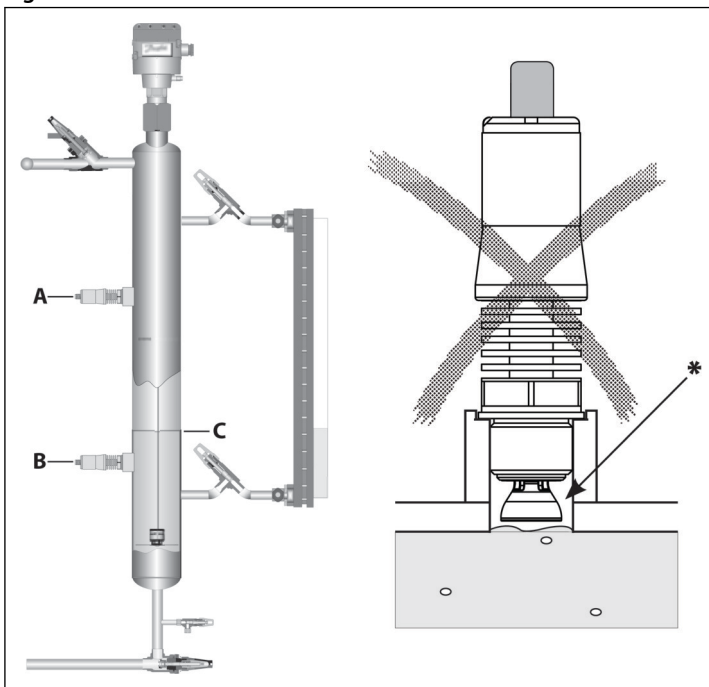

A	Upper LLS 4000/U
B	Lower LLS 4000/U
C	Liq. Level

NOTE:

Horizontal installation recommended. Vertical or inclined installation not recommended: * **Risk of Gas Pockets**

The LLS comes in two versions:

- A standard version, which is applicable for most refrigeration or processing plants, and is fully configurable regarding type of liquid and relay setting.
- A SIL2 version applicable for SIL compliant process plants. This version is non-configurable regarding relay setting (see [Configurable parameters](#)) and is intended specific as the **upper** level switch.

Measuring principle

The measurement principle of the LLS is based on reflectometry with a 4.8 GHz to 6.4 GHz linear sweep (Microwave switch technology). The reflected signal is characterized by a resonance frequency.

The resonance frequency in air is taken as a reference (f_{ref}). When the sensing element is in contact with the liquid, the resonance frequency is shifting to a lower frequency. This is due to the change of the dielectric constant of the medium.

The point level switch monitors the resonance frequency and indicates whether the sensing element is surrounded by liquid or gas. The figure below shows the reference frequency with air (dielectric constant $\epsilon_r=1$) in front of the sensing element and with a liquid dielectric constant $\epsilon_r>1.35$.

Figure 3: Reference frequency

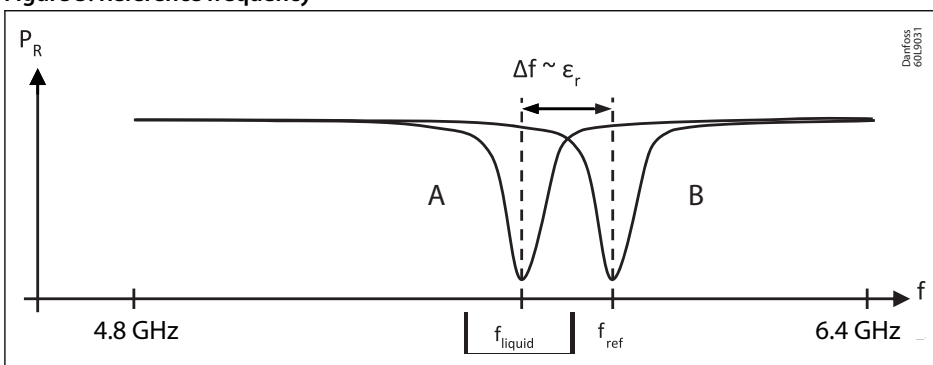

A	With liquid
B	Without liquid

Media

Refrigerants

Table 1: Approved media

	Media	Saturation temperature range
Ammonia and listed H(C)FCs and HFOs. <i>NOTE: For other medias and mixed medias, please contact Danfoss.</i>	R717 (Ammonia)	-50 °C – +105 °C (-58 °F – +221 °F)
	R22 (HCFC)	-50 °C – +86 °C (-58 °F – +187 °F)
	R507A (HCFC)	-50 °C – +60 °C (-58 °F – +140 °F)
	R134a (HFC)	-50 °C – +91 °C (-58 °F – +196 °F)
	R404A (HFC)	-50 °C – +63 °C (-58 °F – +145 °F)
	R407A (HFC)	-50 °C – +72 °C (-58 °F – +162 °F)
	R410A (HFC)	-50 °C – +61 °C (-58 °F – +142 °F)
	R513A (HFC)	-50 °C – +83 °C (-58 °F – +181 °F)
	R1234ze(E) (HFO) ⁽¹⁾	-50 °C – +85 °C (-58 °F – +185 °F)
	PAO (Oil) ⁽²⁾	Max 5000 cP and +120 °C (Max 5000 cP and +248 °F)
	POE (Oil) ⁽²⁾	Max 5000 cP and +120 °C (Max 5000 cP and +248 °F)
	Mineral (Oil) ⁽²⁾	Max 5000 cP and +120 °C (Max 5000 cP and +248 °F)

⁽¹⁾ R1234ze(E) with POE oils (miscible)

⁽²⁾ When detecting oils in Ammonia, H(C)FC and HFO systems, the refrigerant gas temperature above the oil must be lower than 80 °C

New refrigerants

Danfoss products are continually evaluated for use with new refrigerants depending on market requirements.

When a refrigerant is approved for use by Danfoss, it is added to the relevant portfolio, and the R number of the refrigerant (e.g. R513A) will be added to the technical data of the code number. Therefore, products for specific refrigerants are best checked at store.danfoss.com/en/, or by contacting your local Danfoss representative.

Product specification

Electrical data

Table 2: Electrical data

Features	Specifications
Supply	24 V DC +/-25%, 80 mA Standard power supply of type: SELV (Safety Extra Low Voltage) with current limit of max. 8A.
Relay (Solid state)	Max 30 V DC, 200 mA Same power supply as to supply can be used. Observe: In applications with request for SIL2, another separate SELV power supply may be needed. Min. cycles: 1.000.000 Default delay between detection and relay switching: PV (Product Version) All SIL devices, regardless of PV: 1 second, All non-SIL, PV02: 1 second, All non-SIL, PV03 or greater: 2 seconds Product Version number can be found on product label. See Figure 9: Product Label Actual delay highly influenced by media viscosity and shall be validated before commissioning.
Overvoltage category	Category II for supply and output
Electrical connection	M12 (4 pins) male on the device
Measuring technology	Microwave reflectometry (Not TLPR category)
Communication option	Bluetooth comply to ETSI EN 300 328

Mechanical data

Table 3: Mechanical data

Features	Specifications
Max. medium viscosity	5000 cP (Un-detection is delayed up to 20 seconds)
Max. working pressure	140 bar (2030 psi)
Ambient temperature range	-40 °C – 65 °C (-40 °F – 149 °F)
Medium temperature range	-50 °C – 120 °C (-58 °F – 248 °F) Observe restrictions on saturation temperature for approved medias
Operating environment	Pollution degree 3, altitude 2000 max., outdoor use Relative humidity RH4 to RH99 % (IEC 60721-3-4: 1995 Class 4K4)
Connection type	G ¾" or NPT ¾"
Weight	350 g (0.77 lb)
Enclosure rating	IP 66 / IP 67 IEC 60529: 1989 + A1: 1999 + A2: 2013 NEMA 250: 4X
Housing material (electronics)	Transparent and UV resistant. Compliance with IEC 60695-11-10, UL 94 HB
Housing material (mechanics)	Stainless Steel 316L
Vibration resistance	Long term random 7,54 g RMS (Curve A, IEC 60068-2-64) Level on pipes and brackets in direct and immediate vicinity of motors, compressors etc
Resonance frequency	600 – 650 Hz

LLS 4000 Retrofit AKS 38 kit

Figure 4: Material AKS 38 Retrofit housing

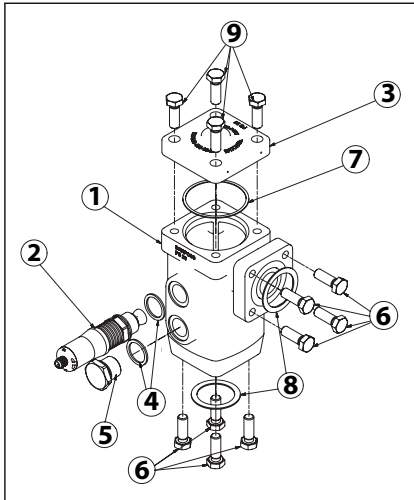

Table 4: Material/Technical data AKS 38 Retrofit housing

Pos	Item	Material	Qty. ⁽¹⁾
1	Housing	Cast Iron, zinc chromated, EN-GJS-400-18-LT	1
2	LLS 4000/U	Stainless Steel	1
3	Top cover	Cast Iron, zinc chromated, EN-GJS-400-18-LT	1
4	Alu gasket	Aluminium	2
5	Plug	Stainless Steel	1
6	Flange bolts	Stainless steel, A2-70 (DIN 267-11) / ASTM A-276	8
7	Gasket	Fiber, non asbestos	1
8	Flange gasket	Fiber, non asbestos	2
9	Top cover bolts	Stainless steel, A2-70 (DIN 267-11) / ASTM A-276	4
	Pressure range	AKS 38 housing is designed for a max. working pressure of 28 barg / 406 psig	
	Temperature range	-50 °C – 65 °C / -58 °F – 149 °F	

⁽¹⁾ QTY included in LLS 4000 Retrofit AKS 38 kit

Wiring diagram

Figure 5: Wiring diagram

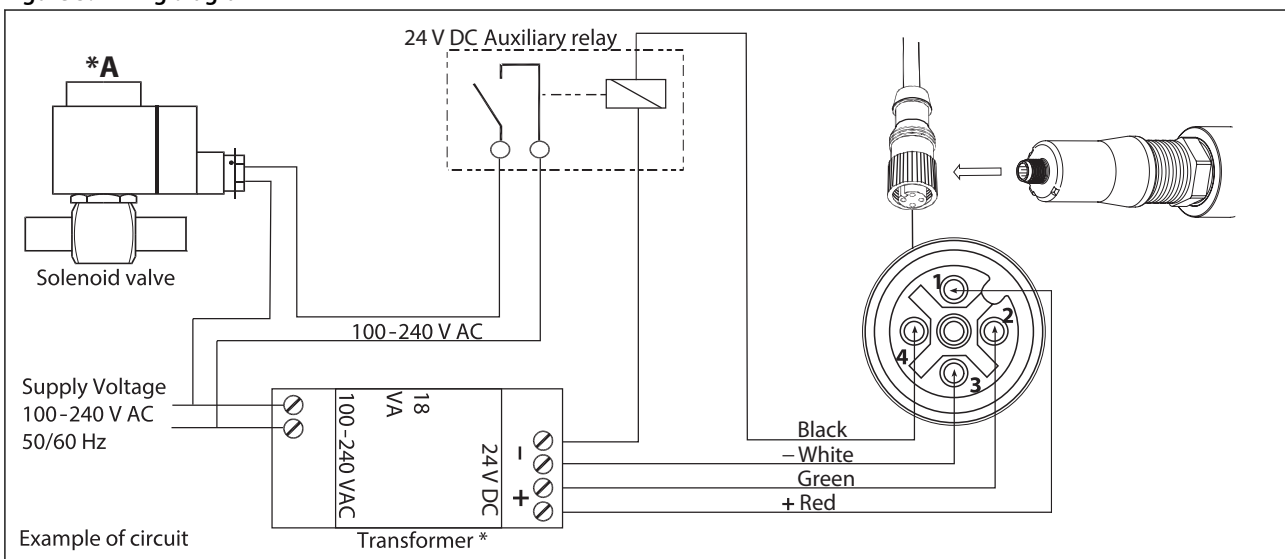

NOTE:

*A. Coil voltage must match supply voltage

Liquid level switch, type LLS 4000 and LLS 4000U

NOTE:

For ON/OFF level control with 1 x LLS 4000 an externally time delay may be used. The time delay shall be set with care and provide a differential NOT higher than 50 – 75 mm under all operating conditions.

Connection types

Beside the two versions the LLS also comes with two different thread types, LLS 4000 and LLS 4000U. They are identical except for the connector thread for installation to the system. The LLS 4000 is provided with G 3/4" thread, while the LLS 4000U is provided with NPT 3/4" thread.

For connection to the actual part of the system appropriate weld connectors are needed. Danfoss offers weld connectors for both G and NPT 3/4" thread as accessory. Please note geometric restrictions below.

Figure 6: LLS 4000/4000U installation

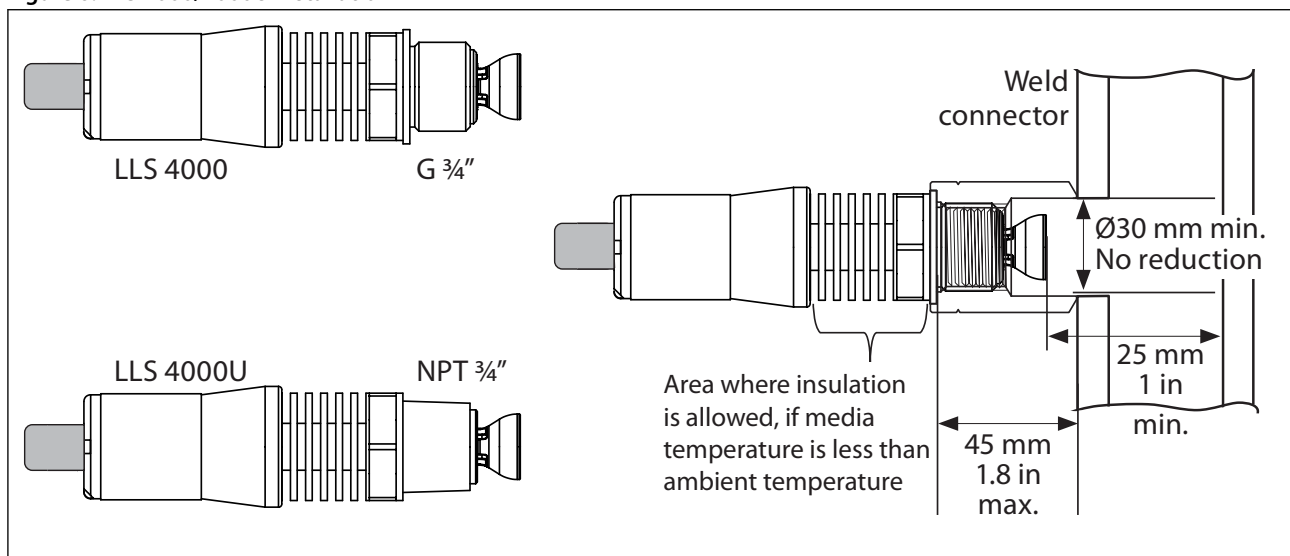

Electrical installation/connection

The LLS 4000 level switch must be installed as one unit (mechanical and electrical assembled) without disassembly to avoid the need for recalibration.

For powering the device, a low power source (LPS) must be used with safety extra low voltage output (SELV) and current limited to 8A maximum.

After connecting the M12 female cable to the power supply and relay circuit the M12 plug can be installed on the M12 male connector and the power can be switched on.

At this stage the green light LED will turn on and be visible through the transparent housing (see [Figure 8](#)).

The LLS is now ready for configuration via the Danfoss Bluetooth app (see [Configurable parameters](#)).

Danfoss M12 cables (ordered separately)

M12 straight cable female x 2 meter,

M12 straight cable female x 8 meter

(M12 angle cable are not recommended)

Figure 7: M12 cable connection

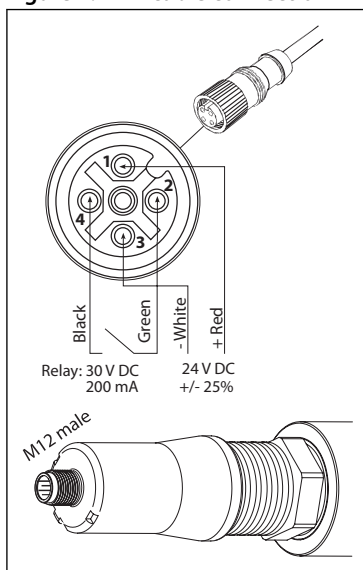

LED light indicators

Figure 8: LED position

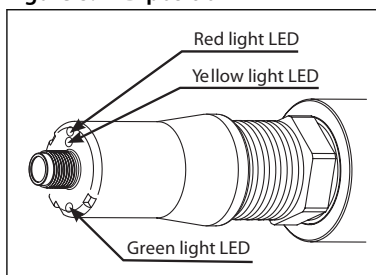

There are three LED indicators inside the LLS 4000 behind the transparent cover.

- Green indicates the state of power to the switch
 - If flashing: Bluetooth connection is established
- Yellow indicates if liquid is in front of switch
- Red indicates if alarm is present

Configurable parameters

The set-up of the LLS 4000 is easy and simple, since only few parameters in the LLS software are configurable.

These are:

- Media type - Ammonia, HFC, HCFC; HFO or Oil. Factory default: Ammonia
- Relay NO (normally open when no liquid) or NC (normally closed when no liquid). Factory default: Normally closed

For plants where factory defaults are valid, the installation and set-up is simply Plug & play.

Table 5 shows possible configurations, relay state for given configuration/liquid level and LED indications.

Table 5: Configuration chart

	Level	Open at no Liquid (Normally Open) (1)	Closed at no Liquid (Normally Closed) (1)	Voltage connected	Level detection	LLS Fault
				Green LED	Yellow LED	Red LED
High Level sensor			SIL2 fixed configuration 	●		
				●	●	
Low Level sensor				●	●	
				●		
Voltage supply outside spec.						
LLS 4000/4000U fault(4)				●	● (5)	●

(1) Configuration dependent. Non-SIL2 fully configurable. SIL2 fixed configuration and only applicable for High Level sensor

(2) Not recommended in these applications: A High Level Alarm may not be registered at a power failure

(3) Not recommended in these applications: A Low Level Alarm may not be registered at a power failure

(4) For failure types please connect the device to the Bluetooth App, enter fault state mode, and read the failure type

(5) Fault can be detected at any detected level, ie. two or all three lights on

Maintenance/service & calibration precautions

NOTE:

The LLS 4000 is considered maintenance free, but there are a few precautions that needs attention.

The fins shall be kept free of dirt, dust, paint and oil etc. that potentially reduces the thermal heat transfer from the fins to the air.

For LLS cleaning use soft cloth dry or wet or compressed air.

If the electronic part is separated from the mechanical part during installation, service or maintenance, the ingress of any foreign substances to the electronic or mechanical part shall be avoided.

Generally the separating of electronic and mechanical parts should be avoided due to calibration, and the mixing of mechanical and electronic parts from different switches must be avoided. In case of the incident mixing of mechanical and electronic parts from different switches, subsequent recalibration might be required.

Prior to calibration the following must be ensured:

The LLS must be out of liquid state (in gas phase), otherwise the calibration might end up incorrect.

This can be secured by either emptying the actual vessel or uninstall the LLS to ambient air.

While in "dry" surroundings, connect power to the LLS switch and perform the calibration.

The Danfoss LLS app includes the calibration possibility. Calibration is not applicable for devices configured for SIL2 devices).

Ice build-up on the LLS switch reduces the accessibility for the Bluetooth connection.

- 10 cm icecap reduces the distance from app device to the LLS to 1 meter
- 20 cm icecap is considered as the maximum to be able to connect

Ice as such do not impact the functionality of the product as far as the minimum ambient temperature is respected.

Bluetooth communication



- A special Danfoss LLS app can be downloaded from Android google play or IOS app store.
- All communication with all LLS installed in a plant is done by use of this app. Communication can only happen with one LLS at a time.
- Each LLS switch includes its own serial number, which will appear in the app when connected. At the same time the green light LED in the actual connected LLS will be flashing.



Bluetooth® word mark and logos are registered trademarks of Bluetooth SIG Inc.

Android and Google Play are registered trademark of Google LLC. App Store is registered trademarks of Apple Inc.

Bluetooth configuration

Always download or update to latest App version. Devices with Firmware PV01 (see product label) must be Firmware updated to latest firmware before configuration. Please contact Danfoss.

The first time parameter setting of an individual LLS switch is done by opening of the app and performing a scan for devices. The app will get a list of LLS that are present at the actual location. The list will include a name and the matching serial number for each of the present LLS.

The name and configurable parameters of any LLS can be changed at any time.

1. Choose the first item on the list and observe which LLS' green LED is flashing
2. Log-in with the provided PIN code. (Default code is 0000. For safety reason the PIN code should be changed afterwards)
3. Touch the Menu Icon
4. Touch the Log-in
5. Enter the Password provided
 - Default code is 12131400. For safety reason the Password should be changed afterwards
6. Rename the device to an up to 24 symbol name (8 symbols displayed)
7. Check the parameter settings and if needed change one or both parameters Media type/ Switch state.
 - Changing media type may require a restart (power off/on) of the LLS 4000/U
8. Note the ID: Name, serial number, media type and switch state
9. Close the app and observe that the green light stops flashing
10. This LLS is now ready for operation
11. If more LLS are present choose the next item on the list and repeat steps 1 to 10

Safety/Approvals

⚠ WARNING:

This is a Class A device. This device may cause radio interference in residential areas. In case of interference, the operator may be required to take appropriate measures. This instrument has to be mounted on a metallic tank. The device is intended to be used in industrial areas.

General warnings/precautions

- Every use that is not described in this data sheet is considered incorrect and is not authorized by the manufacturer.
- The LLS device should only be used with approved media listed under Technical data. Use with other media must be validated by Danfoss before installation.
- Verify that the installation and operating conditions of the device respect those specified in this sheet, especially concerning the supply voltage and environmental conditions.
- All service and maintenance operations must be performed by qualified personnel.
- Installation must comply with local standards and legislation.
- Before carrying out any maintenance operations on the device, disconnect the device from the main power supply.
- Before unscrewing the LLS device from the pipe or tank ensure that pipe or tank is empty and not under pressure.
- Liability for injury or damage caused by incorrect use of the device lies solely with the user.
- Depending on the application, the metallic part of the instrument may be hot or cold.
- If media detection or non-detection by the level switch could generate a hazard the SIL version and specific instructions described in the safety manual (periodic proof test) should be used. The SIL safety manual can be downloaded from the Danfoss web site.

Figure 9: Product Label

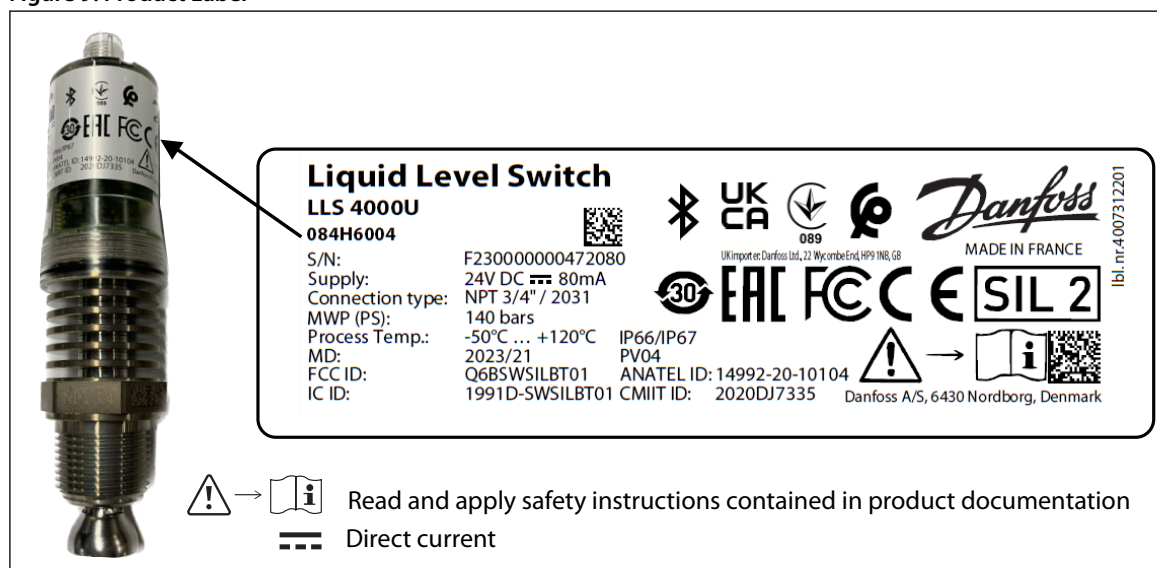

NOTE:

Contact : Danfoss A/S, 6430 Nordborg, Denmark

USA/Canada:

This device complies with Part 15 of the FCC Rules and with RSS-210 of Industry Canada.

Operation is subject to the following two conditions.

1. This device may not cause harmful interference.
2. This device must accept any interference received, including interference that may cause undesired operation.

This equipment has been tested and found to comply with the limits for a Class A digital device, pursuant to Part 15 of the FCC Rules. These limits are designed to provide reasonable protection against harmful interference when the equipment is operated in a commercial environment. This equipment generates, uses, and can radiate radio frequency energy and, if not installed and used in accordance with the instruction manual, may cause harmful interference to radio communications. Operation of this equipment in a residential area is likely to cause harmful interference in which case the user will be required to correct the interference at his own expense.

Under Industry Canada regulations, this radio transmitter may only operate using an antenna of a type and maximum (or lesser) gain approved for the transmitter by Industry Canada. To reduce potential radio interference to other users, the antenna type and its gain should be so chosen that the equivalent isotropically radiated power (e.i.r.p.) is not more than that necessary for successful communication.

Liquid level switch, type LLS 4000 and LLS 4000U

This device complies with FCC and ISED RF radiation exposure limits set forth for general population. This device must be installed to provide a separation distance of at least 20 cm from all persons and must not be co-located or operating in conjunction with any other antenna or transmitter.

The Product Marketing name of the instrument is 'LLS 4000 series'.

Dimensions and weights

Table 6: Dimensions and weights

LLS 4000 [mm]	LLS 4000U [in]
<p>Weight: approx. 350 g / 0.77 lbs</p>	<p>Weight: approx. 350 g / 0.77 lbs</p>

Figure 10: Weld connector 3/4" G or NPT female

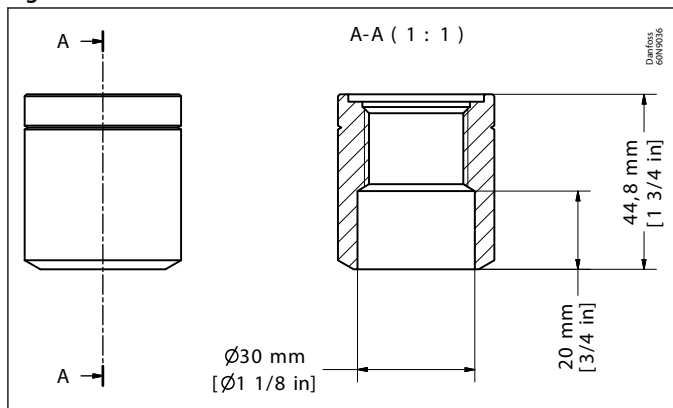
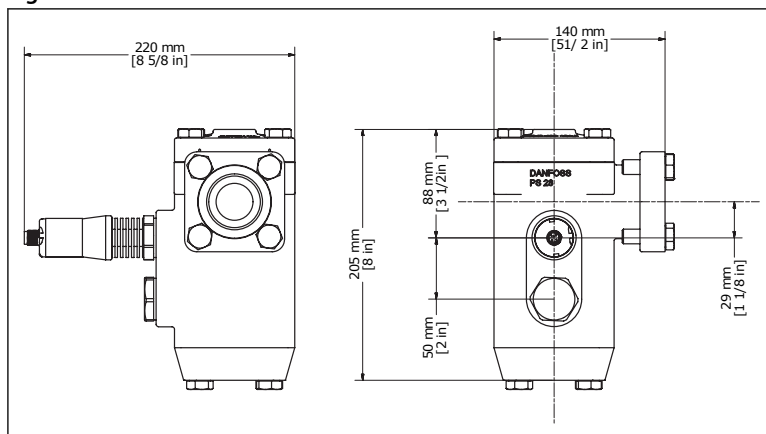

Figure 11: LLS 4000 Retrofit AKS 38 kit



Ordering

Table 7: LLS 4000/4000U

Description	Code Number
LLS 4000 liquid level switch G 3/4" with Alu-gasket (excl. welding connector & M12 cable)	084H6001
LLS 4000 SIL2 liquid level switch G 3/4" with Alu-gasket (excl. welding connector & M12 cable)	084H6002
LLS 4000U liquid level switch NPT 3/4" (excl. welding connector & M12 cable)	084H6003
LLS 4000U SIL2 liquid level switch NPT 3/4" (excl. welding connector & M12 cable)	084H6004

Table 8: Spare parts / Accessories

Description	Code Number
Weld connector G 3/4"	084H6012
Weld connector G 3/4" Stainless Steel	084H6014
Weld connector NPT 3/4" (excl. teflon tape)	084H6015
LLS 4000/U Electronic top part includes O-ring between electronic and mechanical part (spare part not applicable for SIL2 devices; 084H6002 and 084H6004)	084H6010
M12 Danfoss female straight cable, 2 meter (6.6 ft)	034G2201
M12 Danfoss female straight cable, 8 meter (26.2 ft)	034G2200
LLS 4000/U Inspection sealing kit. Contains: 5 pcs of Alugasket for G 3/4" connection, 5 pcs of O-ring between Electronic and Mechanical part	084H6011

Table 9: AKS 38 Retrofit

Description	Code Number
LLS 4000 Retrofit AKS 38 kit incl. 1 x LLS 4000 G 3/4"	148H3504
AK-PS 075, 0,75A/100-240V 50/60Hz Power Supply	080Z0053

Certificates, declarations, and approvals

The list contains all certificates, declarations, and approvals for this product type. Individual code number may have some or all of these approvals, and certain local approvals may not appear on the list.

Some approvals may change over time. You can check the most current status at danfoss.com or contact your local Danfoss representative if you have any questions.

Table 10: EU conformity

Radio Equipment Directive (RED) 2014/53/EU	EN 300 328 V2.1.1 EN 62311: 2008
Low voltage directive 2014/35/EU	EN 61010-1 (edition III)
EMC directive 2014/30/EU	EN 61326-1: 2013
PED	2014/68/EU, A4P3
ROHS 2011/65/EU	2011/65/EU 2015/863/EU

Table 11: Approvals

Approvals	CE: PED, EMC, RED, RoHS, LVD CRN SIL2 FCC IC EAC UA CMIIT ANATEL NBTC
------------------	--

Online support

Danfoss offers a wide range of support along with our products, including digital product information, software, mobile apps, and expert guidance. See the possibilities below.

The Danfoss Product Store



The Danfoss Product Store is your one-stop shop for everything product related—no matter where you are in the world or what area of the cooling industry you work in. Get quick access to essential information like product specs, code numbers, technical documentation, certifications, accessories, and more.

Start browsing at store.danfoss.com.

Find technical documentation



Find the technical documentation you need to get your project up and running. Get direct access to our official collection of data sheets, certificates and declarations, manuals and guides, 3D models and drawings, case stories, brochures, and much more.

Start searching now at www.danfoss.com/en/service-and-support/documentation.

Get local information and support



Local Danfoss websites are the main sources for help and information about our company and products. Find product availability, get the latest regional news, or connect with a nearby expert—all in your own language.

Find your local Danfoss website here: www.danfoss.com/en/choose-region.

Danfoss Learning



Danfoss Learning is a free online learning platform. It features courses and materials specifically designed to help engineers, installers, service technicians, and wholesalers better understand the products, applications, industry topics, and trends that will help you do your job better.

Create your Danfoss Learning account for free at www.danfoss.com/en/service-and-support/learning.

Spare Parts



Get access to the Danfoss spare parts and service kit catalog right from your smartphone. The app contains a wide range of components for air conditioning and refrigeration applications, such as valves, strainers, pressure switches, and sensors.

Download the Spare Parts app for free at www.danfoss.com/en/service-and-support/downloads.

Coolselector®2 - find the best components for you HVAC/R system



Coolselector®2 makes it easy for engineers, consultants, and designers to find and order the best components for refrigeration and air conditioning systems. Run calculations based on your operating conditions and then choose the best setup for your system design.

Download Coolselector®2 for free at coolselector.danfoss.com.

Danfoss A/S

Climate Solutions • danfoss.com • +45 7488 2222

Any information, including, but not limited to information on selection of product, its application or use, product design, weight, dimensions, capacity or any other technical data in product manuals, catalogues descriptions, advertisements, etc. and whether made available in writing, orally, electronically, online or via download, shall be considered informative, and is only binding if and to the extent, explicit reference is made in a quotation or order confirmation. Danfoss cannot accept any responsibility for possible errors in catalogues, brochures, videos and other material. Danfoss reserves the right to alter its products without notice. This also applies to products ordered but not delivered provided that such alterations can be made without changes to form, fit or function of the product.

All trademarks in this material are property of Danfoss A/S or Danfoss group companies. Danfoss and the Danfoss logo are trademarks of Danfoss A/S. All rights reserved.