

Date 13/5/2020
 Customer
 Offer



San Toribio, 6 28031 MADRID
 +34/913030426 com@frimetal.es

DIRECT EXPANSION EVAPORATOR

FRB-510

Model Capacity **9,1 kW**
 Required Capacity **0,0 kW**

Materials

Tubes Copper
 Fins Aluminium
 Casing Aluminun and galvanized steel white coated RAL-9002

Duties

Fin Spacing **7 mm**
 Air Flow **6670 m³/h**
 Air Velocity **2,36 m/s**
 Available Air Static Pressure **0 Pa**
 Air throw **14 m**
 Air Inlet Temperature **-20,0 °C**
 Outlet Air Temperature **-23,3 °C**
 Evaporating Temperature **-27,0 °C**
 Temperature difference DT1 **7 K**
 Refrigerant **R404A**

Options

Electrical defrost

Coil

Fin Spacing **7 mm**
 Finned Length **1400 mm**
 Surface **46,8 m²**
 Internal Volume **15,1 dm³**

Installer Information

Net weight **84 kg**
 Inlet liquid distributor **1 x 5/8"**
 Outlet line **1 x 28 mm**
 Electric defrost power **6400 W**

AC Fan motors ErP compliant

Power supply **1~230V/50Hz**
 Fans Nr. **2**
 Blade Diameter **400 mm**
 Speed **1400 rpm**

Total absorbed power **320 W**
 Total absorbed current **1,5 A**
 Noise Power Level **76 dB(A)**
 Noise Pressure Level **45 dB(A)**
 Distance **10 m**

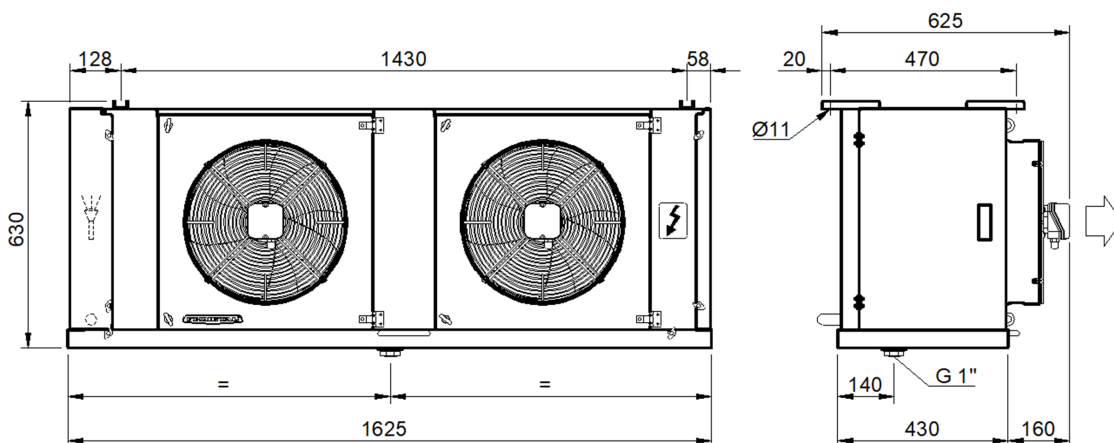

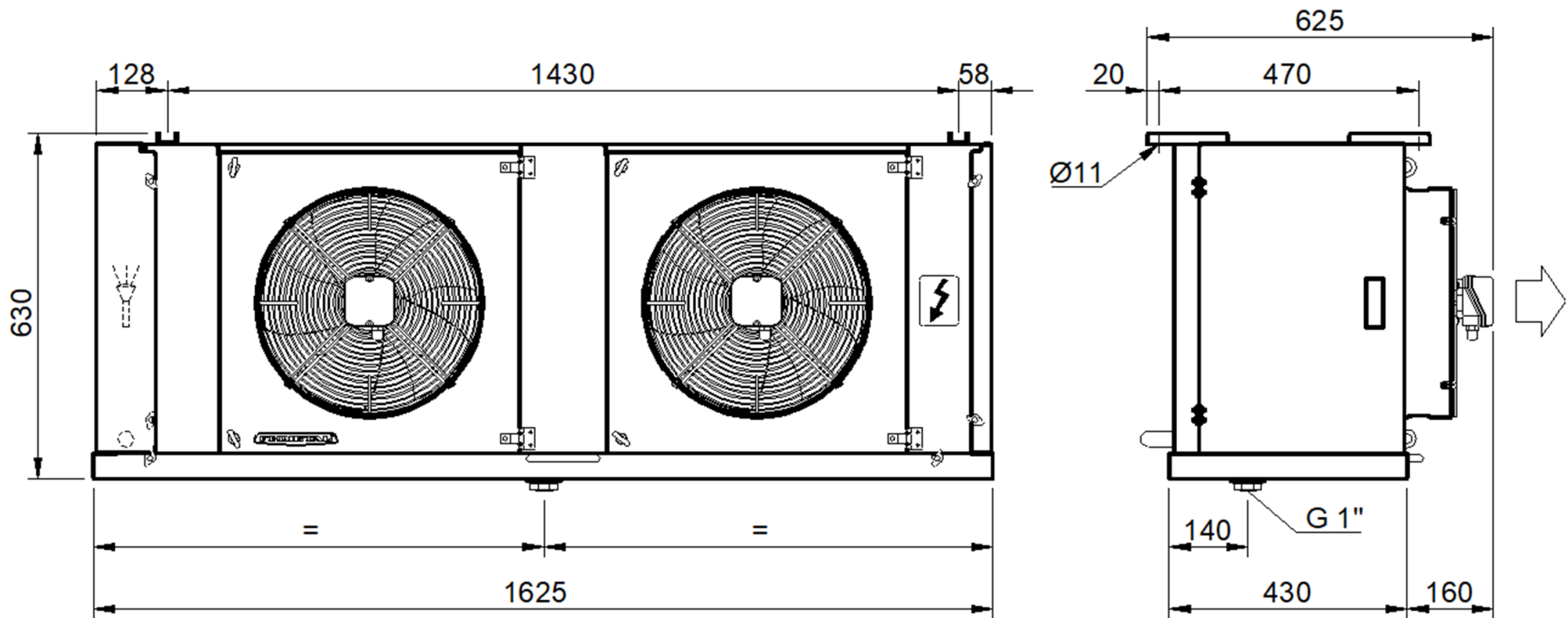

DIRECT EXPANSION EVAPORATOR - FRB-510



FRIMETAL, s.a.
 San Toribio, 6
 28031 MADRID
 +34/913030426 - +34/917774761