

Data sheet

Actuators for modulating control

AME 110NLX - with position feedback signal

Description



The actuators are used together with automatically balanced combination valve type AB-QM for DN 10 to DN 32.

The actuator can be used with fan coil units, induction units, small reheaters, recoolers and zone applications in which hot/cold water is the controlled medium.

Main data:

- Position feedback or output signal (X=0-10 VDC)
- Gap detection at stem up position
- Modulating control
- Force switch-off at stem down position prevents overload of actuator and valve.
- No tools required for mounting
- Maintenance-free lifetime
- Low-noise operation
- Self-positioning process
- Halogen free cables

Ordering

Type	Supply voltage	Speed	Cable length	Code No.
AME 110 NLX	24 V~	24 s/mm	1,5 m	082H8060
			5,0 m	082H8062
			10 m	082H8064

Note: Package of actuators is Single Pack - each actuator is packed in separate box.

Technical data

Power supply	V	24 ±20 %; AC	
Power consumption	running	VA	1,5
	standby	W	0,4
Frequency	Hz	50/60	
Control input Y	V	0-10 (2-10) Ri = 200 kΩ	
	mA	0-20 (4-20) Ri = 500 Ω	
Control output X	V	0-10 Ro _(min) = 38 kΩ	
Closing force	N	130	
Stroke	mm	5	
Speed	s/mm	24	
Max. medium temperature		120	
Ambient temperature	°C	0 ... 55	
Storage and transport temperature		-40 ... 70	
Ambient humidity		95% r.h., non-condensing	
Protection class		II	
Grade of enclosure		IP 42	
Weight		0,3 kg	
 - marking in accordance with standards	Low Voltage Directive 2014/35/EU, EN 60730-1:2011, EN 60730-2-14:1997 + A1:2001 + A11:2005 + A2:2008 EMC Directive 2014/30/EU, EN 61000-6-2:2005, EN61000-6-3:2007 + A1:2011		

Installation

Mechanical

The actuator should be mounted with the valve stem in either horizontal position or pointing upwards.

The actuator is fixed to the valve body by means of a mounting ring, which requires no tools for mounting. The ring should be tightened by hand.

Electrical

Important: It is strongly recommended that the mechanical installation is completed before the electrical installation.

Auto sleep mode

1. If actuator AME 110NLX is charged by 24 V supply voltage and if it is not installed on AB-QM valve, it will stop in lower position and switch off all LED indicators after 5 minutes.
2. **It is mandatory to drive the spindle of the actuator to upper position before it will be installed on AB-QM valve (please refer to manual override drawings)!**

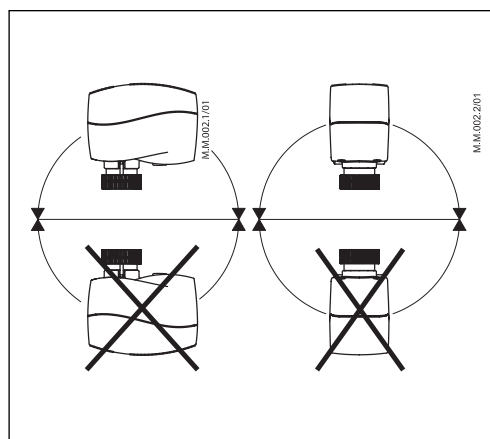

3. Auto sleep mode switches back to learning mode by pressing RESET button or by cycling power supply.

Each actuator is supplied with the connecting cable for the controller.

Installation procedure

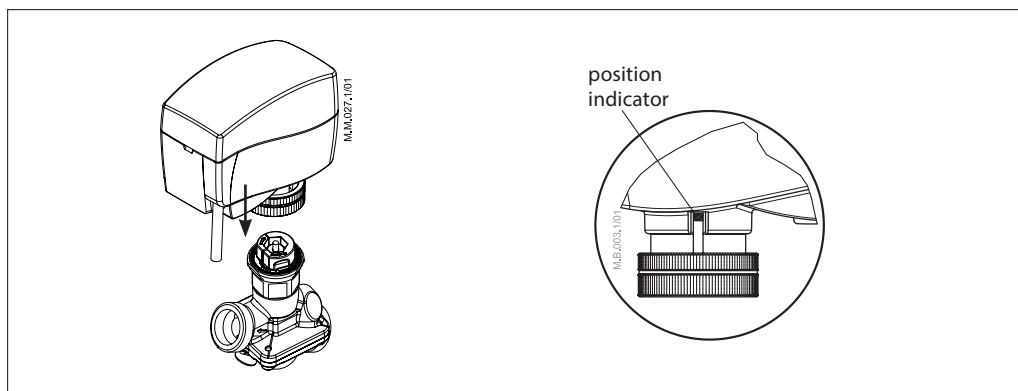

1. Check the valve neck. The actuator should be in stem up position (factory setting).
Ensure that the actuator is mounted securely on the valve body
2. Wire the actuator according to the wiring diagram
3. The direction of the stem movement can be observed on the position indicator

Wiring

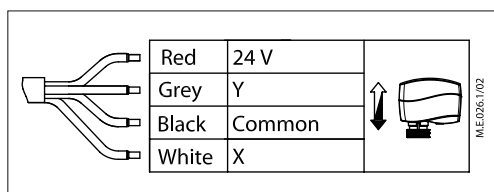

Commissioning

The factory setting of the spindle is the fully stem up position because of easier mechanical connection of the actuator on the valve.

DIP Switch Setting
(for service purposes only)

The actuator has a function selection DIP switch under the removable cover.

The switch provides the following functions:

- SW1:
0/2 - Input signal range selector
If set to OFF position, the input signal is in the range from 2-10 V (voltage input) or from 4-20 mA (current input).
If set to ON position, the input signal is in the range from 0-10 V (voltage input) or from 0-20 mA (current input).
- SW2:
D/I - Direct or inverse acting selector
If set to OFF position, the actuator is direct acting (stem contracts as voltage increases). If the actuator is set to ON position, the actuator is inverse acting (stem extracts as voltage increases).
- SW3:
---/Seq - Normal or sequential mode selector:
If set to OFF position, the actuator is working in range 0(2)-10 V or 0(4)-20 mA.
If set to ON position, the actuator is working in sequential range; 0(2)-5(6) V or (0(4)-10(12) mA) or (5(6)-10 V) or (10(12)-20 mA).
- SW4:
0-5 V/5-10 V - Input signal range in sequential mode:
If set to OFF position, the actuator is working in sequential range 0(2)-5(6) V or 0(4)-10(12) mA.
If set to ON position, the actuator is working in sequential range; 5(6)-10 V or 10(12)-20 mA.

- SW5:
LIN/LOG - Linear or equal percentage flow through valve selector
If set to OFF position, the flow through the valve is equal percentage-wise equals the control signal.
If set to ON position, the flow through the valve is linear in accordance to the control signal.
- SW6:
---/ASTK - Anti-blocking function
Exercises the valve to avoid blocking in periods when the heating/cooling is off. If set to ON position (ASTK), the valve motion is switched on. The actuator opens and closes the valve every 7 days.
If set to OFF position (---), the function is disabled.
- SW7:
U/I - Input signal type selector
If set to OFF position, voltage input is selected. If set to ON position, current input is selected.

Note:
The reset button ① will cause the actuator to go through a self stroking cycle (press it for 2 s).
Remark:
When the manual override has been used, the output signal (X) is not correct until the actuator reaches its end position.

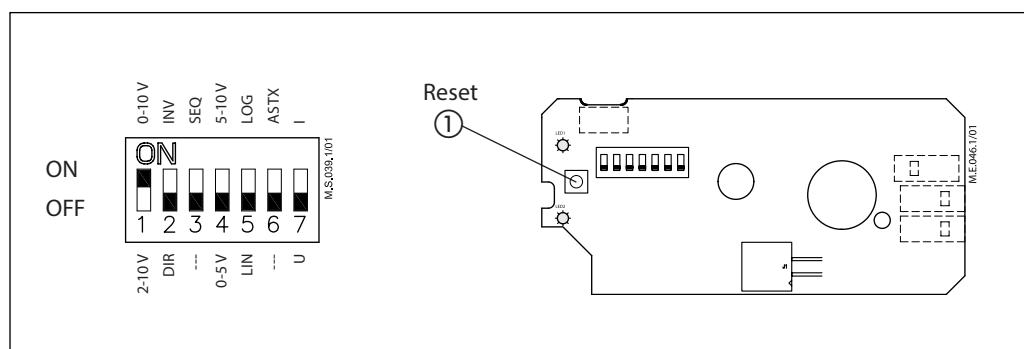

Manual override (for service purposes only)

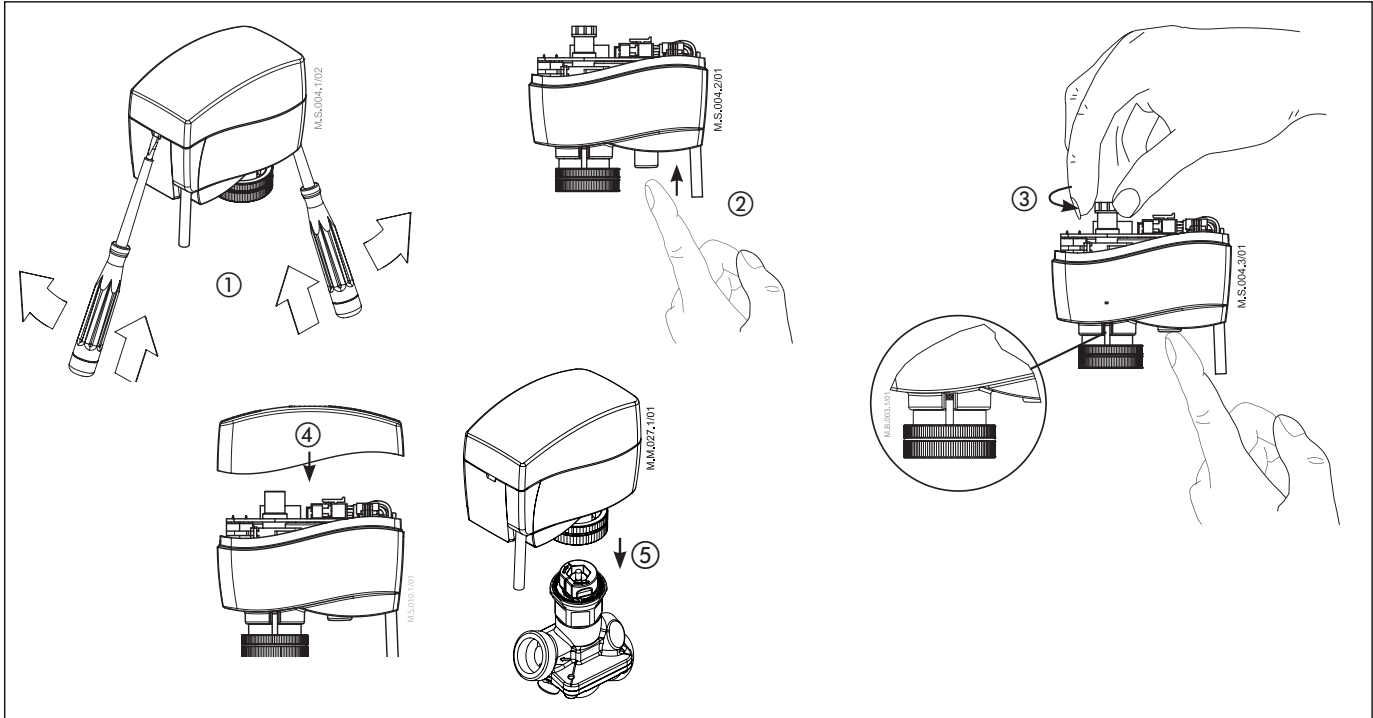

Caution:
Do not manually operate the drive if power is connected!

Do not dismantle the actuator from the valve when it is in a stem down position!

If dismantled in a stem down position, there is a high risk that the actuator gets stuck.

- Remove cover ①
- Press and hold the button ② (on the bottom side of the actuator) during manual override ③
- Replace cover ④
- Install actuator on valve ⑤

Remark:

A 'click' sound after energising the actuator indicates that the gear wheel has jumped into normal position.

If manual override has been used, the Y signal will not be correct until the actuator has reached its end position. If this is not accepted, reset the actuator.

Dimensions

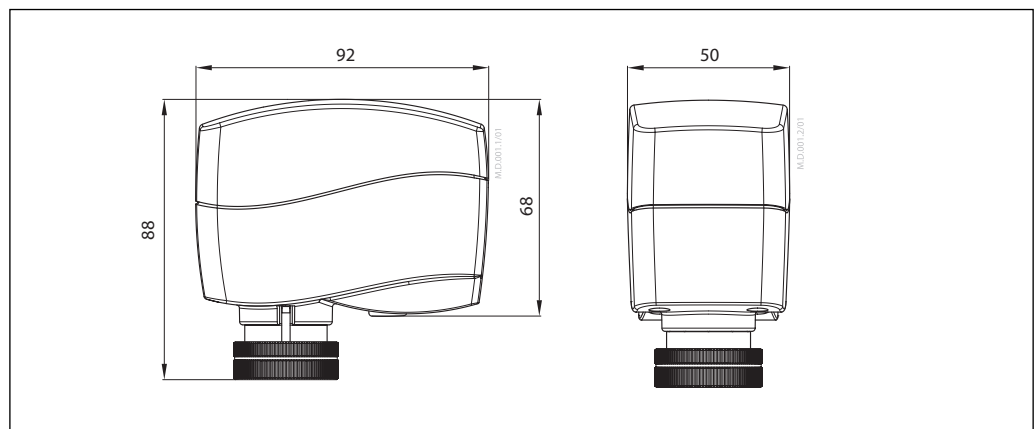

Danfoss A/S

Climate Solutions • danfoss.com • +45 7488 2222

All information, including, but not limited to information on selection of product, its application or use, product design, weight, dimensions, capacity or any other technical data in product manuals, catalogues descriptions, advertisements, etc. and whether made available in writing, orally, electronically, online or via download, shall be considered informative, and is only binding if and to the extent, explicit reference is made in a quotation or order confirmation. Danfoss cannot accept any responsibility for possible errors in catalogues, brochures, videos and other material. Danfoss reserves the right to alter its products without notice. This also applies to products ordered but not delivered provided that such alterations can be made without changes to form, fit or function of the product.

All trademarks in this material are property of Danfoss A/S or Danfoss group companies. Danfoss and the Danfoss logo are trademarks of Danfoss A/S. All rights reserved.