

Sonde e sensori

Probes and sensors

CAREL



Guida alla scelta e all'installazione ottimale
Selection and optimal installation guide

**LEGGI E CONSERVA
QUESTE ISTRUZIONI**
**READ AND SAVE
THESE INSTRUCTIONS**

  **NO POWER
& SIGNAL
CABLES
TOGETHER**
READ CAREFULLY IN THE TEXT!

AVVERTENZE



CAREL basa lo sviluppo dei suoi prodotti su una esperienza pluridecennale nel campo HVAC, sull'investimento continuo in innovazione tecnologica di prodotto, su procedure e processi di qualità rigorosi con test in-circuit e funzionali sul 100% della sua produzione, sulle più innovative tecnologie di produzione disponibili nel mercato. CAREL e le sue filiali/affiliate non garantiscono tuttavia che tutti gli aspetti del prodotto e del software incluso nel prodotto risponderanno alle esigenze dell'applicazione finale, pur essendo il prodotto costruito secondo le tecniche dello stato dell'arte.

Il cliente (costruttore, progettista o installatore dell'equipaggiamento finale) si assume ogni responsabilità e rischio in relazione alla configurazione del prodotto per il raggiungimento dei risultati previsti in relazione all'installazione e/o equipaggiamento finale specifico.

CAREL in questo caso, previ accordi specifici, può intervenire come consulente per la buona riuscita dello start-up macchina finale/applicazione, ma in nessun caso può essere ritenuta responsabile per il buon funzionamento del equipaggiamento/impianto finale.

Il prodotto CAREL è un prodotto avanzato, il cui funzionamento è specificato nella documentazione tecnica fornita col prodotto o scaricabile, anche anteriormente all'acquisto, dal sito internet www.carel.com.

Ogni prodotto CAREL, in relazione al suo avanzato livello tecnologico, necessita di una fase di qualifica / configurazione / programmazione / commissioning affinché possa funzionare al meglio per l'applicazione specifica. La mancanza di tale fase di studio, come indicata nel manuale, può generare malfunzionamenti nei prodotti finali di cui CAREL non potrà essere ritenuta responsabile.

Soltanto personale qualificato può installare o eseguire interventi di assistenza tecnica sul prodotto.

Il cliente finale deve usare il prodotto solo nelle modalità descritte nella documentazione relativa al prodotto stesso.

Senza che ciò escluda la doverosa osservanza di ulteriori avvertenze presenti nel manuale, si evidenzia che è in ogni caso necessario, per ciascun Prodotto di CAREL:

- Evitare che i circuiti elettronici si bagnino. La pioggia, l'umidità e tutti i tipi di liquidi o la condensa contengono sostanze minerali corrosive che possono danneggiare i circuiti elettronici. In ogni caso il prodotto va usato o stoccato in ambienti che rispettano i limiti di temperatura ed umidità specificati nel manuale.
- Non installare il dispositivo in ambienti particolarmente caldi. Temperature troppo elevate possono ridurre la durata dei dispositivi elettronici, danneggiarli e deformare o fondere le parti in plastica. In ogni caso il prodotto va usato o stoccato in ambienti che rispettano i limiti di temperatura ed umidità specificati nel manuale.
- Non tentare di aprire il dispositivo in modi diversi da quelli indicati nel manuale.
- Non fare cadere, battere o scuotere il dispositivo, poiché i circuiti interni e i meccanismi potrebbero subire danni irreparabili.
- Non usare prodotti chimici corrosivi, solventi o detersivi aggressivi per pulire il dispositivo.
- Non utilizzare il prodotto in ambiti applicativi diversi da quanto specificato nel manuale tecnico.

Tutti i suggerimenti sopra riportati sono validi altresì per il controllo, schede seriali, chiavi di programmazione o comunque per qualunque altro accessorio del portfolio prodotti CAREL.

CAREL adotta una politica di continuo sviluppo. Pertanto CAREL si riserva il diritto di effettuare modifiche e miglioramenti a qualsiasi prodotto descritto nel presente documento senza previo preavviso.

I dati tecnici presenti nel manuale possono subire modifiche senza obbligo di preavviso

La responsabilità di CAREL in relazione al proprio prodotto è regolata dalle condizioni generali di contratto CAREL editate nel sito www.carel.com e/o da specifici accordi con i clienti; in particolare, nella misura consentita dalla normativa applicabile, in nessun caso CAREL, i suoi dipendenti o le sue filiali/affiliate saranno responsabili di eventuali mancati guadagni o vendite, perdite di dati e di informazioni, costi di merci o servizi sostitutivi, danni a cose o persone, interruzioni di attività, o eventuali danni diretti, indiretti, incidentali, patrimoniali, di copertura, punitivi, speciali o consequenziali in qualunque modo causati, siano essi contrattuali, extra contrattuali o dovuti a negligenza o altra responsabilità derivanti dall'installazione, utilizzo o impossibilità di utilizzo del prodotto, anche se CAREL o le sue filiali/affiliate siano state avvisate della possibilità di danni.

SMALTIMENTO



INFORMAZIONE AGLI UTENTI PER IL CORRETTO TRATTAMENTO DEI RIFIUTI DI APPARECCHIATURE ELETTRICHE ED ELETTRONICHE (RAEE)

In riferimento alla Direttiva 2002/96/CE del Parlamento Europeo e del Consiglio del 27 gennaio 2003 e alle relative normative nazionali di attuazione, Vi informiamo che:

1. sussiste l'obbligo di non smaltire i RAEE come rifiuti urbani e di effettuare, per detti rifiuti, una raccolta separata;
2. Per lo smaltimento vanno utilizzati i sistemi di raccolta pubblici o privati previsti dalla leggi locali. È inoltre possibile riconsegnare al distributore l'apparecchiatura a fine vita in caso di acquisto di una nuova;
3. questa apparecchiatura può contenere sostanze pericolose: un uso improprio o uno smaltimento non corretto potrebbe avere effetti negativi sulla salute umana e sull'ambiente;
4. il simbolo (contenitore di spazzatura su ruote barrato) riportato sul prodotto o sulla confezione e sul foglio istruzioni indica che l'apparecchiatura è stata immessa sul mercato dopo il 13 agosto 2005 e che deve essere oggetto di raccolta separata;
5. in caso di smaltimento abusivo dei rifiuti elettrici ed elettronici sono previste sanzioni stabilite dalle vigenti normative locali in materia di smaltimento.

Garanzia sui materiali: 2 anni (dalla data di produzione, escluse le parti di consumo).

Omologazioni: la qualità e la sicurezza dei prodotti CAREL INDUSTRIES Hq sono garantite dal sistema di progettazione e produzione certificato ISO 9001.

ATTENZIONE: separare quanto più possibile i cavi delle sonde e degli ingressi digitali dai cavi dei carichi induttivi e di potenza per evitare possibili disturbi elettromagnetici.

Non inserire mai nelle stesse canaline (comprese quelle dei quadri elettrici) cavi di potenza e cavi di segnale

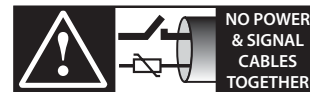

READ CAREFULLY IN THE TEXT!

Indice

1. SENSORI PASSIVI DI TEMPERATURA	7
1.1 Guida alla scelta in base all'applicazione	7
2. CONSIDERAZIONI SULLA TRASMISSIONE DI CALORE NELLA MISURAZIONE DELLA TEMPERATURA	8
3. SENSORI ATTIVI DI TEMPERATURA E UMIDITÀ	8
4. SENSORI ATTIVI DI QUALITÀ DELL'ARIA	9
5. SENSORI FUGHE GAS REFRIGERANTE (R22, R134A, R290, R404A, R407C-F, R410A, R744, ETILENE)	9
6. SENSORI DI PRESSIONE	10
7. SENSORI DIFFERENZIALI DI PRESSIONE	10
8. SENSORI DI ALLAGAMENTO	11
9. SENSORI ANTIGELO	11
10. SENSORI FUMO-FUOCO	11
11. SENSORI DI LIVELLO	11
12. INDICAZIONE DI INSTALLAZIONE PER CAMPO APPLICATIVO	12
12.1 AHU.....	12
12.2 HVAC: Chiller/Pompa di calore A/W - W/W	14
12.3 CRAC.....	16
12.4 CRAC CW	18
12.5 HVAC: Applicazione raffreddamento tecnologico/di processo Chiller condensati ad aria/acqua.....	20
12.6 HVAC: Applicazioni commerciali/residenziali - Roof Top.....	22
12.7 Abbattitore.....	24
12.8 Banchi frigo autonomi/Refrigeratore di bevande.....	26
12.9 Banchi frigo autonomi condensati ad acqua	28
12.10 Banchi frigo centralizzati/canalizzati	30
12.11 Cella frigorifera.....	32
12.12 Impianto CO ₂ transcritico.....	34
12.13 Impianto CO ₂ Subcritico	35
13. ULTERIORI RACCOMANDAZIONI	36
13.1 Sensori di temperatura e umidità ambiente.....	36
13.2 Sensori temperatura e umidità condotta	37
13.3 Sensori di temperatura	38
13.4 Sensori di pressione.....	38
13.5 Sensori fughe gas.....	38

1. SENSORI PASSIVI DI TEMPERATURA

Premessa: Scopo del presente manuale è di guidare l'utente alla scelta e alla corretta installazione delle sonde per ridurre gli errori tipici di misura dovuti a:

- l'influenza della resistenza di contatto termico, del materiale conduttore e dell'ambiente circostante la sonda;
- l'irraggiamento;
- la stratificazione delle temperature.

1.1 Guida alla scelta in base all'applicazione

La scelta della miglior condizione di installazione di un sensore dipende dall'esigenza di misura (cosa devo misurare, dove sono posizionati i sensori? Pres. bassa temperatura e alta umidità – probabile condensa e ghiacciamento sul sensore; alta temperatura – danneggiamento guaina

o del sistema di fissaggio):

1. In base al fluido (gas o liquido), statico o in movimento che determina stratificazione del fluido misurato, scambio termico con il sistema di misura (elemento di misura, guaina, tubazione, ecc.); tutto ciò che aumenta la resistenza e l'inerzia termica causando perciò errori di vario genere nella lettura;
2. In base alla dinamicità (se il fenomeno da misurare è molto lento con piccole variazioni nel tempo, oppure presenta caratteristiche di variabilità importante in tempi brevi);
4. In base al campo di lavoro con variazioni di temperatura positiva – negativa, oppure variazioni di temperatura solo positiva o solo negativa;
5. In base alla presenza e al tipo di contaminanti (no UV -> no esposizione diretta al sole del cavo sonda o delle plastiche).

Nota: Gli schemi applicativi riportati in seguito, rappresentano delle tipiche installazioni. Alcune applicazioni possono essere la combinazione di più schemi.

Codice	Tipo	Campo di lavoro [°C]	IP	Contenitore cappuccio		Materiale		NOTE
				Ø [mm]	L [mm]	cappuccio	cavo	
NTC*HP*	NTC	-50T105	IP67	6x5	15	poliolefina	poliolefina	Cavo singolo isolamento
NTC*WH*	NTC	-50T105	IP68	6	50	AISI316	TPE	
NTC*WF*	NTC	-50T105	IP67	4	40	AISI316	TPE	
NTC*WP*	NTC	-50T105	IP67	6	100/200/300	AISI316	TPE	
NTC*HF*	NTC	-50T105	IP67	6x6	20	TPE	TPE	Con fascetta di fissaggio cavo singolo isolamento
NTC*WS*	NTC	-40T105	IP67	6x6	20	TPE + Cu	TPE	Con fascetta di fissaggio cavo doppio isolamento
NTC*HT*	NTC	-30T150	IP67	5	20/50	PE/AISI316	PE	Due versioni (PE e AISI)
NTC*LT*	NTC	-80T105	IP67	6x6	150	AISI316		
NTC*PS*	NTC	-50T105	IP67	98x20	105	Santoprene	TPE	Simulazione temperatura prodotto
TSN*	NTC	-40T120	IP68	3	13	AISI316	-	A immersione diretta M 1/8 Gas - PN40
TSC*	NTC	-40T90	IP68	4	15	Ottone nichelato	TPE	A immersione diretta M14 - PN40
NTC*INF*	NTC	-50T90	IP67	5/4	150/169/100	AISI304/316	siliconico	idoneo a uso alimentare per misurare la temperatura cuore prodotto
NTC*WG*	NTC	-50T105	IP67	6x6	40	Alluminio	TPE	Utilizzata su vetrine insieme a sonda umidità per attivare antiappannanti
PT100*	PT100	-50T250 0T400	IP65	6	100	AISI316	gomma siliconica	
PT1*HP*	PT1000	-50T105	IP67	6x5	15	poliolefina	poliolefina	Cavo singolo isolamento
PT1*WF*	PT1000	-50T105	IP67	4	40	AISI316	TPE	
PT1*WP*	PT1000	-50T105	IP67	6	50	AISI316	TPE	
PT1*HT*	PT1000	-50T250	IP67	6	40	AISI304	Resina siliconica	
PT1*HF*	PT1000	-50T105	IP67	6x6	20	TPE	TPE	Con fascetta di fissaggio cavo singolo isolamento
PT1*PS*	PT1000	-50T105	IP67	98x20	105	Santoprene	TPE	Applicazioni speciali
TST*	PT1000	-40T120	IP68	3	13	AISI316	-	A immersione diretta M 1/8 Gas - PN40
TSM*	PT1000	-40T90	IP68	4	15	Ottone nichelato	TPE	A immersione diretta M14 - PN25
TSQ*	PT1000	-50T350	IP65	3	150	AISI316		
PT1*INF*	PT1000	-50T200	IP67	5/4	100	AISI316	TPE	idoneo a uso alimentare per misurare la temperatura cuore prodotto
PTC*	PTC	-30T105	IP67	6	40		PVC	

Tab. 1.a

Nota: per maggiori dettagli tecnici consultare il manuale sensori passivi +030220655 (IT-EN).



2. CONSIDERAZIONI SULLA TRASMISSIONE DI CALORE NELLA MISURAZIONE DELLA TEMPERATURA

Premessa: Qualsiasi sia il metodo utilizzato di rilevazione della temperatura, la temperatura misurata non è mai la temperatura reale del fluido che si vuole misurare.

La distanza dal valore reale (che costituisce l'errore di misura) è determinata dal processo stesso di trasmissione del calore che interessa qualsiasi oggetto o fluido soggetto a una differenza di temperatura rispetto al fluido o all'oggetto vicino, oppure a una variazione dinamica di temperatura (differenza rispetto ai valori precedenti).

I fattori che allontanano la misura dal valore reale sono:

1. Differenza di temperatura dell'ambiente circostante il punto di misura;
2. Massa termica dell'insieme che costituisce il rilevatore di temperatura (es. tubo, pozzetto, sonda) che aumenta la costante di tempo complessiva di misura.

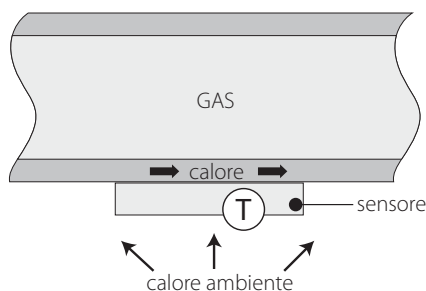

Comunemente nella misura della temperatura di un fluido, viene spesso sottovalutata l'influenza della temperatura dell'ambiente circostante il punto di misura sulla misura stessa. Quando la differenza tra il punto di misura e l'ambiente è sensibile (qualche decina di gradi) l'errore non è più trascurabile.

Quando si deve regolare una temperatura soggetta a variazioni la bontà della regolazione dipende anche dalla costante di tempo della misura:

quanto più bassa è la costante di tempo, tanto più veloce è l'inseguimento di una temperatura che sta cambiando e quindi tanto minore sarà l'errore istantaneo tra valore letto e valore reale.

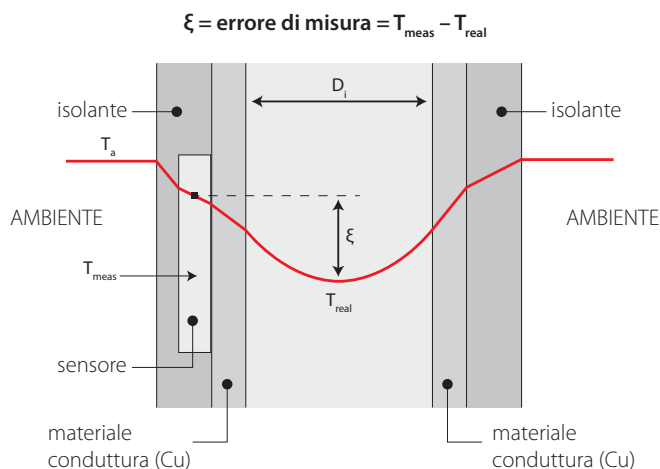

Nota: L'errore di misura generato dall'influenza della temperatura ambiente è particolarmente importante con tubazioni di diametro ridotto: il rapporto tra le masse (tubo e fluido) è infatti inversamente proporzionale al diametro della tubazione

$$\frac{A_e}{V_i} = \frac{D_e \cdot \pi}{D_i^2 \cdot \pi/4} \cong \frac{4}{D}$$

A_e = area superficie esterna
 V_i = volume interno

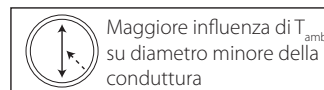

3. SENSORI ATTIVI DI TEMPERATURA E UMIDITÀ

	Tipo di uscita							
	Temperatura	Umidità	NTC Carel	NTC Carel e -0,5...1 V - 4...20 mA	-0,5...1 V - 4...20 mA	NTC Carel e 0...10 V	0...10 V	Seriale RS485
Condotta	-10 T60°C	-	DPDT011000	-	DPDT010000	-	-	DPDT014000
	-10 T60°C	10...90%	-	DPDC111000	DPDC110000	-	DPDC112000	DPDC114000
	-20 to 70°C	0...100%	-	-	DPDC210000	-	DPDC212000	DPDC214000
Ambiente industriale	-10 T60°C	-	DPPT011000	-	DPPT010000	-	-	DPPT014000
	-10 T60°C	10...90%	-	DPPC111000	DPPC110000	-	DPPC112000	DPPC114000
	-20 to 70°C	0...100%	-	-	DPPC210000	-	DPPC212000	DPPC214000
Montaggio a parete	-10 T60°C	-	DPWT011000	-	DPWT010000	-	-	DPWT014000
	-10 T60°C	10...90%	-	DPWC111000	DPWC110000	DPWC115000	DPWC112000	DPWC114000
Immersione	-	30...90°C	-	-	ASIT030000	-	-	-
	-	30...90°C Cavo L= 2m	-	-	ASET030000	-	-	-
	-	30...90°C Cavo L= 3m	-	-	ASET030001	-	-	-
Sensore remoto	-	30...90°C Cavo L= 4m	-	-	ASET030002	-	-	-

Tab. 3.a

Nota: per maggiori dettagli tecnici consultare il manuale sensori attivi +030220660 (IT-EN)



4. SENSORI ATTIVI DI QUALITÀ DELL'ARIA

Versione	Codici Carel DP*Q*	Uscite	Codice prodotto Carel
VOC sensore di qualità dell'aria montaggio a parete		0 to 10V – 4 to 20 mA	DPWQ306000
CO2 sensore di qualità dell'aria montaggio a parete		0 to 10V	DPWQ402000
VOC + CO2 sensore di qualità dell'aria montaggio a parete		0 to 10V	DPWQ502000
VOC sensore di qualità dell'aria versione condotta		0 to 10V – 4 to 20 mA	DPDQ306000
CO2 sensore di qualità dell'aria versione condotta		0 to 10V	DPDQ402000
VOC + CO2 sensore di qualità dell'aria versione condotta		0 to 10V	DPDQ502000

Tab. 4.a

Nota: per maggiori dettagli tecnici consultare i fogli istruzioni dei sensori qualità dell'aria:

VOC	VOC + CO ₂
+050001290 - IT	+050001300 - IT
+050001291 - GB	+050001301 - GB
+050001292 - FR	+050001302 - FR
+050001293 - DE	+050001303 - DE
+050001294 - RU	+050001304 - RU



5. SENSORI FUGHE GAS REFRIGERANTE (R22, R134A, R290, R404A, R407C-F, R410A, R744, ETILENE)

Semiconduttore (IP41)	Semiconduttore con sensore remoto 5 m (IP66)	Descrizione
DPWLA07000	DPWLA27000	Sensore rilevamento gas R22
DPWLB07000	DPWLB27000	Sensore rilevamento gas R134a
DPWLC07000	DPWLC27000	Sensore rilevamento gas R404a
DPWLR07000		Sensore rilevamento gas R407a
DPWLD07000	DPWLD27000	Sensore rilevamento gas R407c
DPWLS07000		Sensore rilevamento gas R407f
DPWLE07000	DPWLE27000	Sensore rilevamento gas R410a
DPWLT07000	DPWLT27000	Sensore rilevamento gas R507a
DPWLG07000		Sensore rilevamento gas NH3
DPWLQ07000		Sensore rilevamento gas ETILENE
DPWLP07000		Sensore rilevamento gas R290

Infrared (IP66)	Infrared con sensore remoto 5 m (IP66)	Descrizione
DPWL417000	DPWL427000	Sensore rilevam. gas CO ₂

Tab. 5.a

Nota: per maggiori dettagli tecnici consultare il manuale specifico: codice +0300035EN o +0300035IT



6. SENSORI DI PRESSIONE

Scelta del sensore di pressione in funzione della pressione di lavoro.

Gas	Evaporatore bassa temperatura	Evaporatore media e alta temperatura	Condensatore
R134a	SPKT0053R*/P* (0-5 V; -1.0...4.2 barg) SPKT0021C*/D* (4-20 mA; -0.5...7.0 barg) SPKS0019R1 (0-5 V; 0...9 barg) versione a saldare	SPKT0013R*/P* (0-5 V; -1...9.3 barg) SPKT0011C*/D* (4-20 mA; 0...10 barg) SPKS0019R1 (0-5 V; 0...9 barg) versione a saldare	SPKT0033R*/P* (0-5 V; 0...34.5 barg) SPKT0031C*/D* (4-20 mA; 0...30 barg) SPKS0039R1 (0-5 V; 0...34 barg) versione a saldare
R290	SPKT0013R*/P* (0-5 V; -1...9.3 barg) SPKT0011C*/D* (4-20 mA; 0...10 barg) SPKS0019R1 (0-5 V; 0...9 barg) versione a saldare	SPKT0013R*/P* (0-5 V; -1...9.3 barg) SPKT0011C*/D* (4-20 mA; 0...10 barg) SPKS0019R1 (0-5 V; 0...9 barg) versione a saldare	SPKT0033R*/P* (0-5 V; 0...34.5 barg) SPKT0031C*/D* (4-20 mA; 0...30 barg) SPKS0039R1 (0-5 V; 0...34 barg) versione a saldare
R404a	SPKT0013R*/P* (0-5 V; -1...9.3 barg) SPKT0011C*/D* (4-20 mA; 0...10 barg) SPKS0019R1 (0-5 V; 0...9 barg) versione a saldare	SPKT0013R*/P* (0-5 V; -1...9.3 barg) SPKT0011C*/D* (4-20 mA; 0...10 barg) SPKS0019R1 (0-5 V; 0...9 barg) versione a saldare	SPKT0033R*/P* (0-5 V; 0...34.5 barg) SPKT0031C*/D* (4-20 mA; 0...30 barg) SPKS0039R1 (0-5 V; 0...34 barg) versione a saldare
R407A	SPKT0013R*/P* (0-5 V; -1...9.3 barg) SPKT0011C*/D* (4-20 mA; 0...10 barg) SPKS0019R1 (0-5 V; 0...9 barg) versione a saldare	SPKT0013R*/P* (0-5 V; -1...9.3 barg) ⁽¹⁾ SPKT0011C*/D* (4-20 mA; 0...10 barg) ⁽¹⁾ SPKS0019R1 (0-5 V; 0...9 barg) versione a saldare	SPKT0033R*/P* (0-5 V; 0...34.5 barg) SPKT0031C*/D* (4-20 mA; 0...30 barg) SPKS0039R1 (0-5 V; 0...34 barg) versione a saldare
R407C	SPKT0013R*/P* (0-5 V; -1...9.3 barg) SPKT0011C*/D* (4-20 mA; 0...10 barg) SPKS0019R1 (0-5 V; 0...9 barg) versione a saldare	SPKT0013R*/P* (0-5 V; -1...9.3 barg) ⁽¹⁾ SPKT0011C*/D* (4-20 mA; 0...10 barg) ⁽¹⁾ SPKS0019R1 (0-5 V; 0...9 barg) versione a saldare	SPKT0033R*/P* (0-5 V; 0...34.5 barg) SPKT0031C*/D* (4-20 mA; 0...30 barg) SPKS0039R1 (0-5 V; 0...34 barg) versione a saldare
R407F	SPKT0013R*/P* (0-5 V; -1...9.3 barg) SPKT0011C*/D* (4-20 mA; 0...10 barg) SPKS0019R1 (0-5 V; 0...9 barg) versione a saldare	SPKT0013R*/P* (0-5 V; -1...9.3 barg) ⁽¹⁾ SPKT0011C*/D* (4-20 mA; 0...10 barg) ⁽¹⁾ SPKS0019R1 (0-5 V; 0...9 barg) versione a saldare	SPKT0033R*/P* (0-5 V; 0...34.5 barg) SPKT0031C*/D* (4-20 mA; 0...30 barg) SPKS0039R1 (0-5 V; 0...34 barg) versione a saldare
R410A	SPKT0043R*/P* (0-5 V; 0...17.3 barg) SPKT0041C*/D* (4-20 mA; 0...18.2 barg) SPKS00F9R1 (0-5 V; 0...19 barg) versione a saldare	SPKT0043R*/P* (0-5 V; 0...17.3 barg) SPKT0041C*/D* (4-20 mA; 0...18.2 barg) SPKS00F9R1 (0-5 V; 0...19 barg) versione a saldare	SPKT00B6R*/P* (0-5 V; 0...45 barg) SPKT00B1C*/D* (4-20 mA; 0...44.8 barg) SPKS00B9R1 (0-5 V; 0...45 barg) versione a saldare
R717	SPKT0021C*/D* (4-20 mA; -0.5...7 barg)	SPKT0011C*/D* (4-20 mA; 0...10 barg)	SPKT0031C*/D* (4-20 mA; 0...30 barg)
R744	SPKT00G1C*/D* (4-20 mA; 0-60 barg)	SPKT00G1C*/D* (4-20 mA; 0-60 barg)	SPKT00H8C* (4-20 mA; 0-120 barg) SPKT00D8C* (4-20 mA; 0-150 barg)

Tab. 6.a

(1): in caso di utilizzo HVAC usare rispettivamente

- SPKT0043R*/P* (0-5 V 0...17.3 barg)
- SPKT0041C*/D* (4-20 mA 0...18.2 barg)
- SPKS00F9R1 (0-5 V 0...19 barg) versione a saldare

Documentazione specifica: per maggiori dettagli tecnici consultare i fogli istruzioni dei trasduttori di pressione:

- cavo e connettore +050000484
- 4-20 mA serie C +050000486 (IT-EN) alternativa: 4-20 mA serie D +050000595 (IT-EN)
- 4-20 mA serie C high pressure +050000596 (IT-EN)
- 0-5 V serie R +050000485 (IT-EN) alternativa: 0-5 V serie P +050000598 (IT-EN)
- 0-5 V serie S +050000488 (IT-EN)
- 0-5 V serie SPKS* versione a saldare +050000489 (IT-EN)

Nota: I sensori a saldare della serie SPKS*R* sono in accordo con il regolamento 842/2006 della normativa F-GAS che richiede dispositivi installati al sistema sigillati ermeticamente e solidamente fissati tramite saldatura.



7. SENSORI DIFFERENZIALI DI PRESSIONE

Vedi Fogli istruzione specifici:

Sensori attivi 4...20 mA +050000651 (IT-EN)

Codice	Campo di lavoro (aggiustabile)	Uscita
SPKD00U5N0	0 ... 1000 Pa 0 ... 2500 Pa 0 ... 3000 Pa 0 ... 5000 Pa	4 ... 20 mA
SPKD00C5N0	- 50 ... + 50 Pa - 100 ... + 100 Pa 0 ... + 50 Pa 0 ... + 100 Pa	4 ... 20 mA

Tab. 7.a



Sensori on-off +050000645 (IT-EN)

Codice	Descrizione	Range mbar	
DCPD000100	Pressostato differenziale	0,5 - 5,0	
DCPD010100	Pressostato differenziale	0,5 - 5,0	con Kit di collegamento
DCPD001100	Pressostato differenziale	0,2 - 2,0	
DCPD011100	Pressostato differenziale	0,2 - 2,0	con Kit di collegamento

Tab. 7.b



8. SENSORI DI ALLAGAMENTO

riferimento F.I. +050004116

Codice	Descrizione
FLOE000010	Rilevatore anti allagamento
FLOS000000	Sonda puntiforme
FLOR000000	Sonda a banda sensibile 25 m

Tab. 8.a



9. SENSORI ANTIGELO

riferimento F.I. +050000646

Codice	Descrizione	Range (°C)
DCTF000320	Termostato antigelo monostadio	-10...15

Tab. 9.a



10. SENSORI FUMO-FUOCO

riferimento F.I. +050000520

Fumo

Codice	Tensione di alimentazione
SFFS000000	12...24 Vdc

Tab. 10.a

Fuoco

Codice	Tensione di alimentazione
SFFF000000	12...24 Vdc

Tab. 10.b



11. SENSORI DI LIVELLO

riferimento F.I. +0500075ML

Codice	Descrizione
LSR0013000	Sensore di livello – connessione meccanica 2" Gas
LSR0023000	Sensore di livello – connessione meccanica con flangia

Tab. 11.a



12. INDICAZIONE DI INSTALLAZIONE PER CAMPO APPLICATIVO

12.1 AHU

LEGENDA

T	Temperatura
rH%	Umidità relativa
ΔP	Differenziale di pressione
CO ₂	CO ₂
V _{OC}	Composti organici volatili

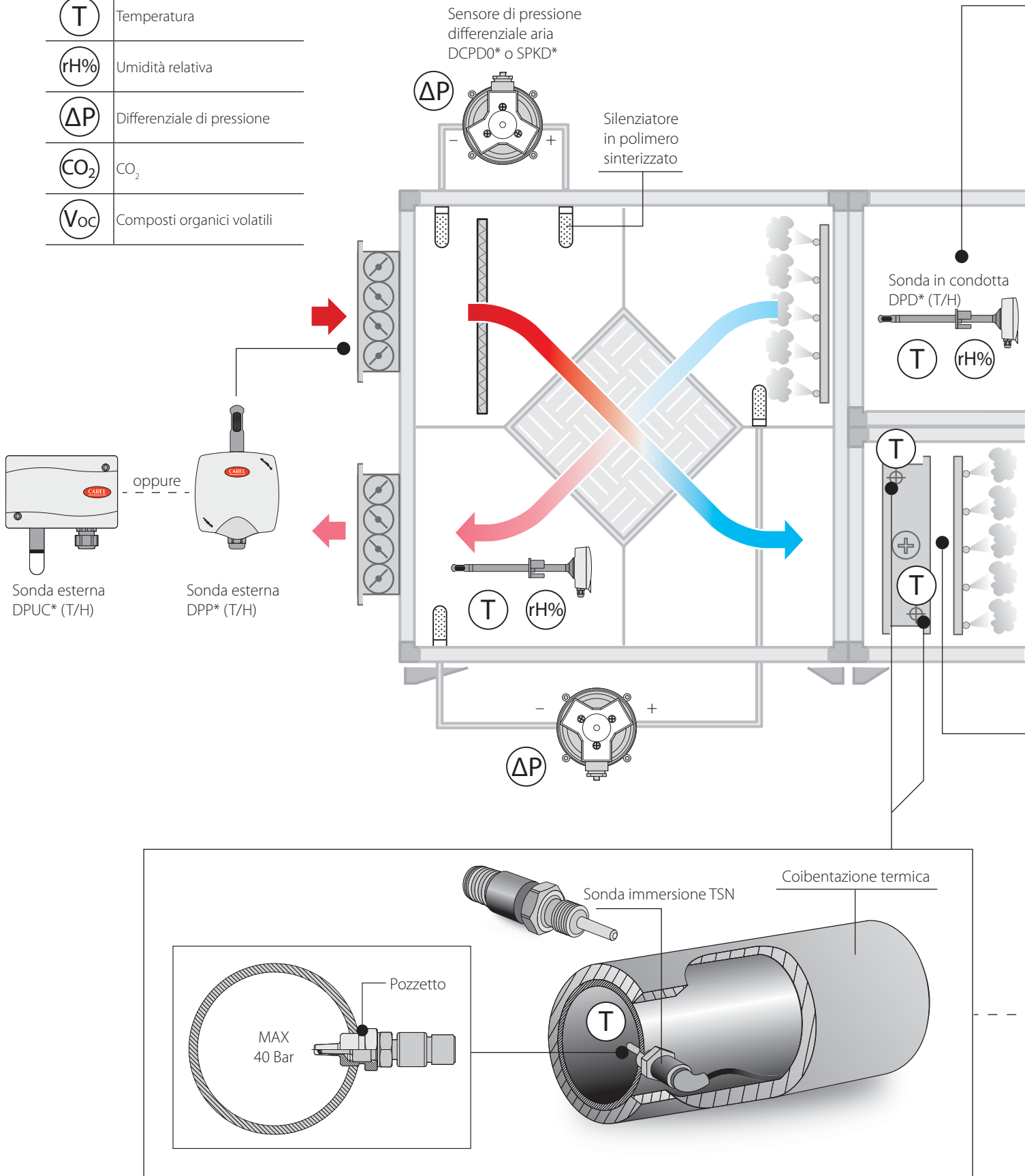

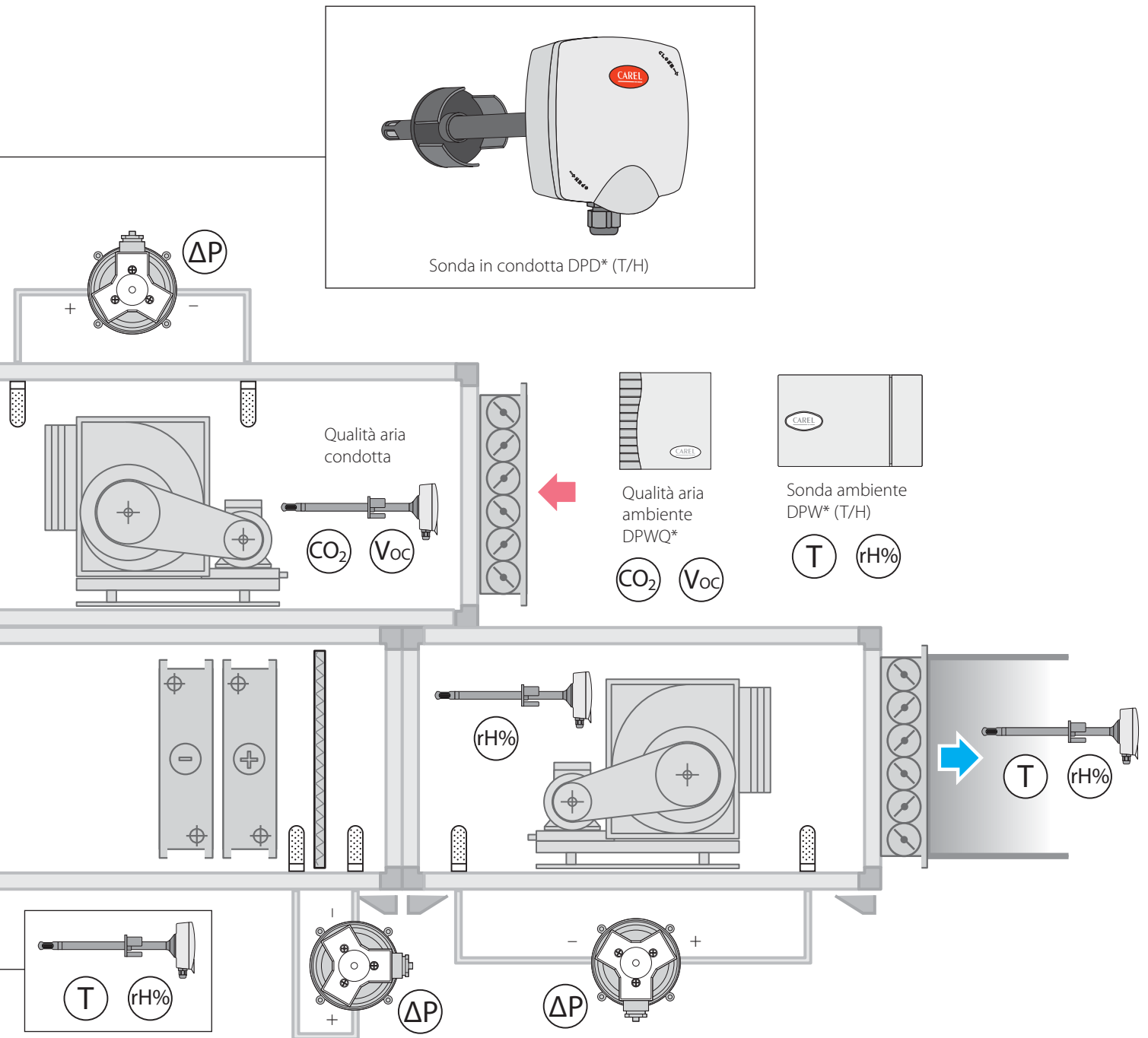

Soluzione alternativa

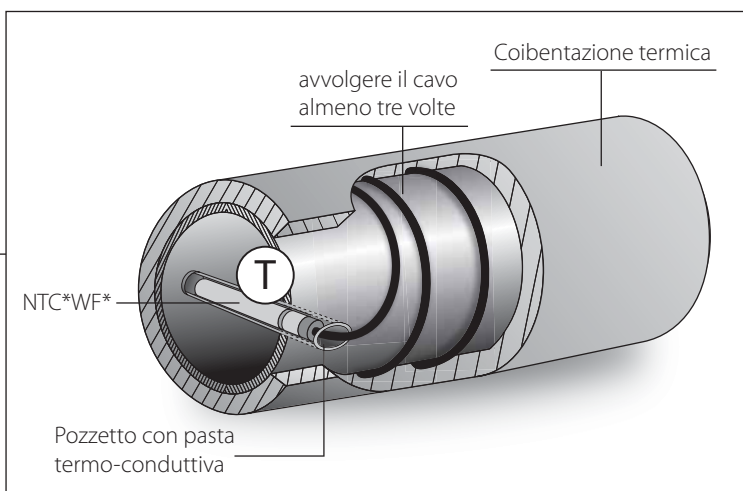

12.2 HVAC: Chiller/Pompa di calore A/W - W/W

LEGENDA

T	Temperatura
P	Pressione

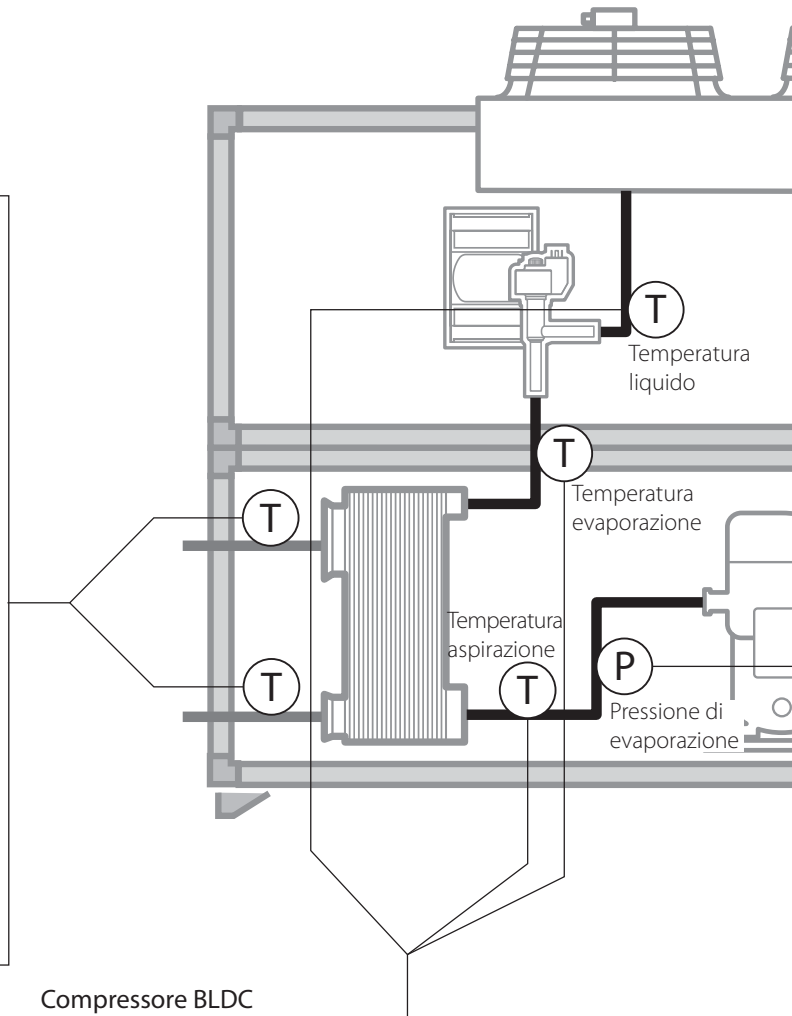
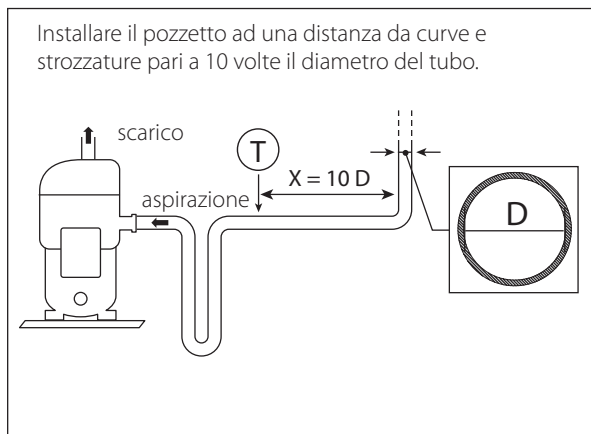
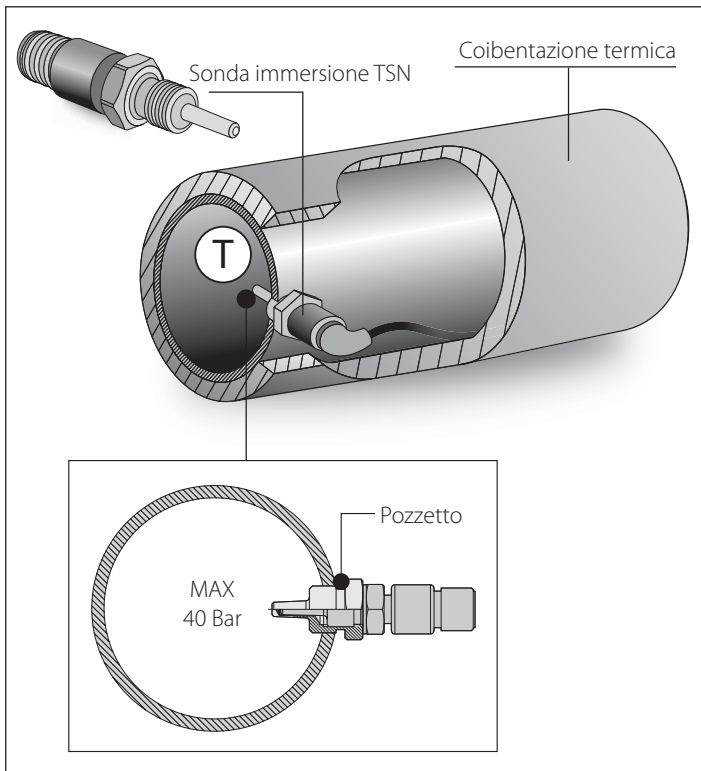

Compressore BLDC

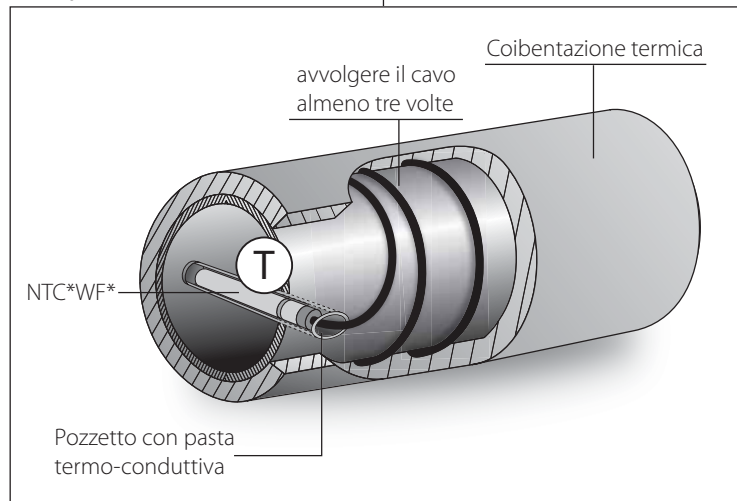

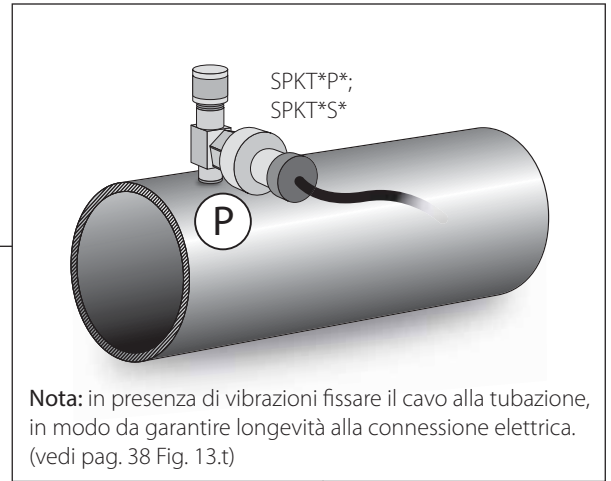
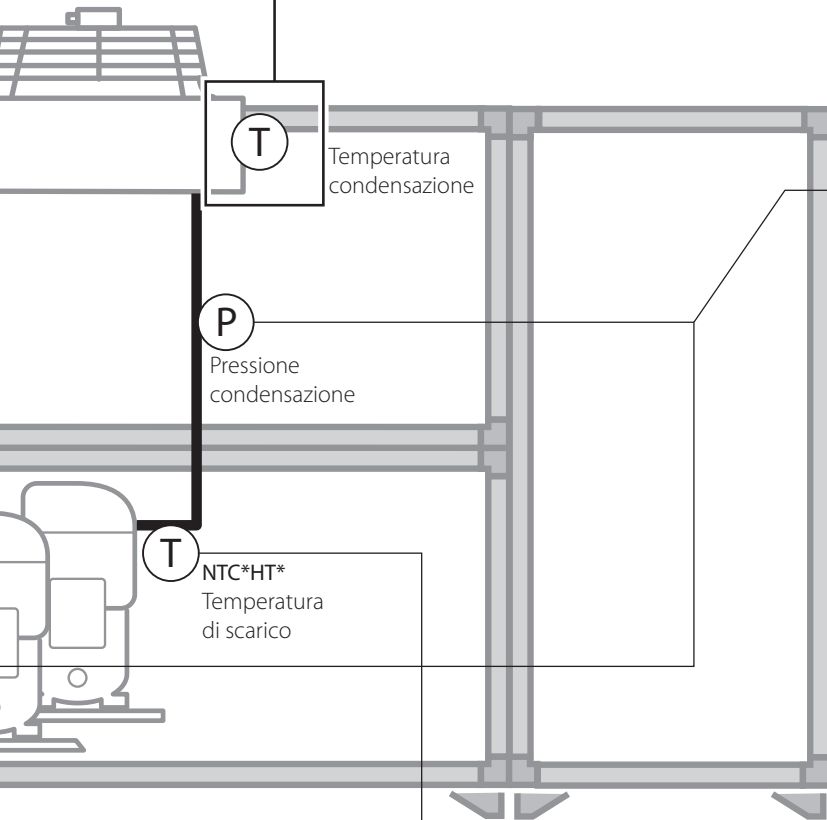
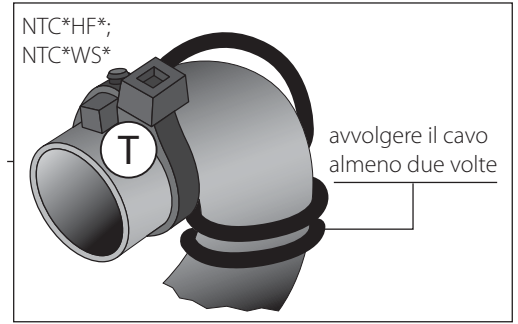
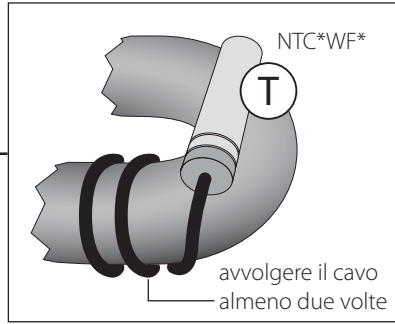
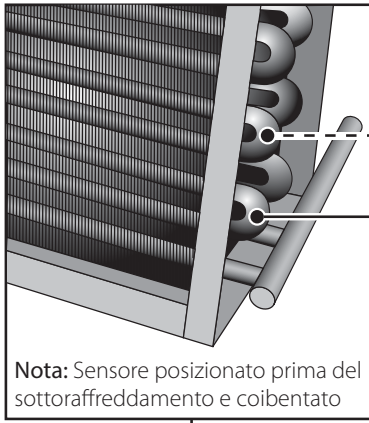

Collegamento con capillare

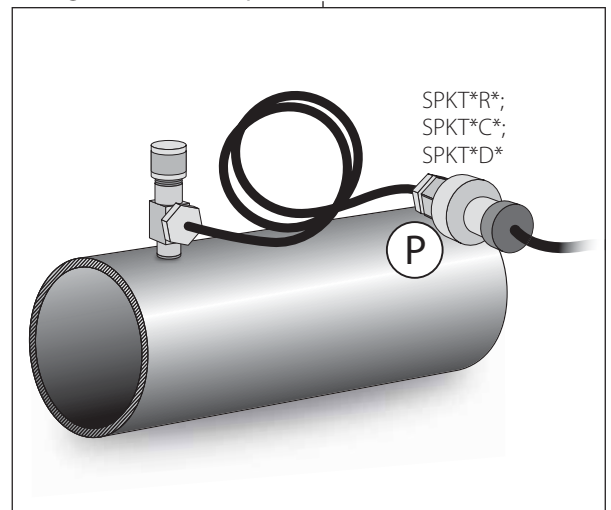

Compressore ON/OFF

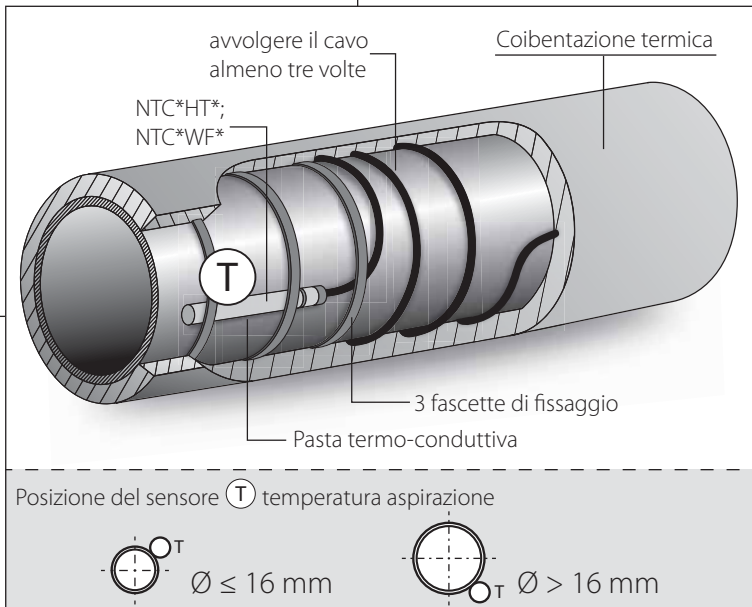

Collegamento a saldare

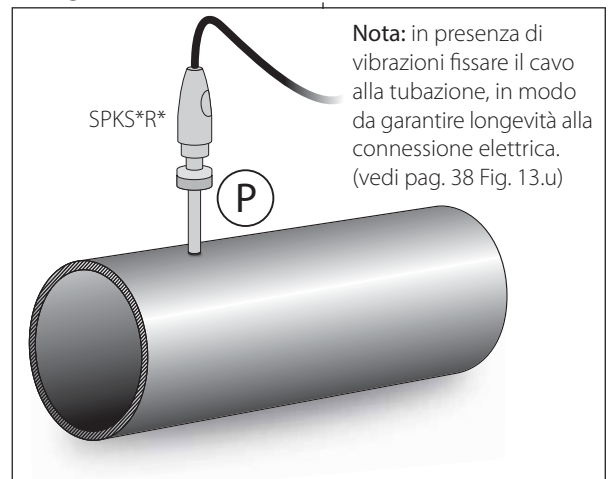

12.3 CRAC

LEGENDA

T	Temperatura
P	Pressione
rH%	Umidità relativa
ΔP	Differenziale di pressione
S	Fumo
F	Fuoco
L	Sensore anti allagamento

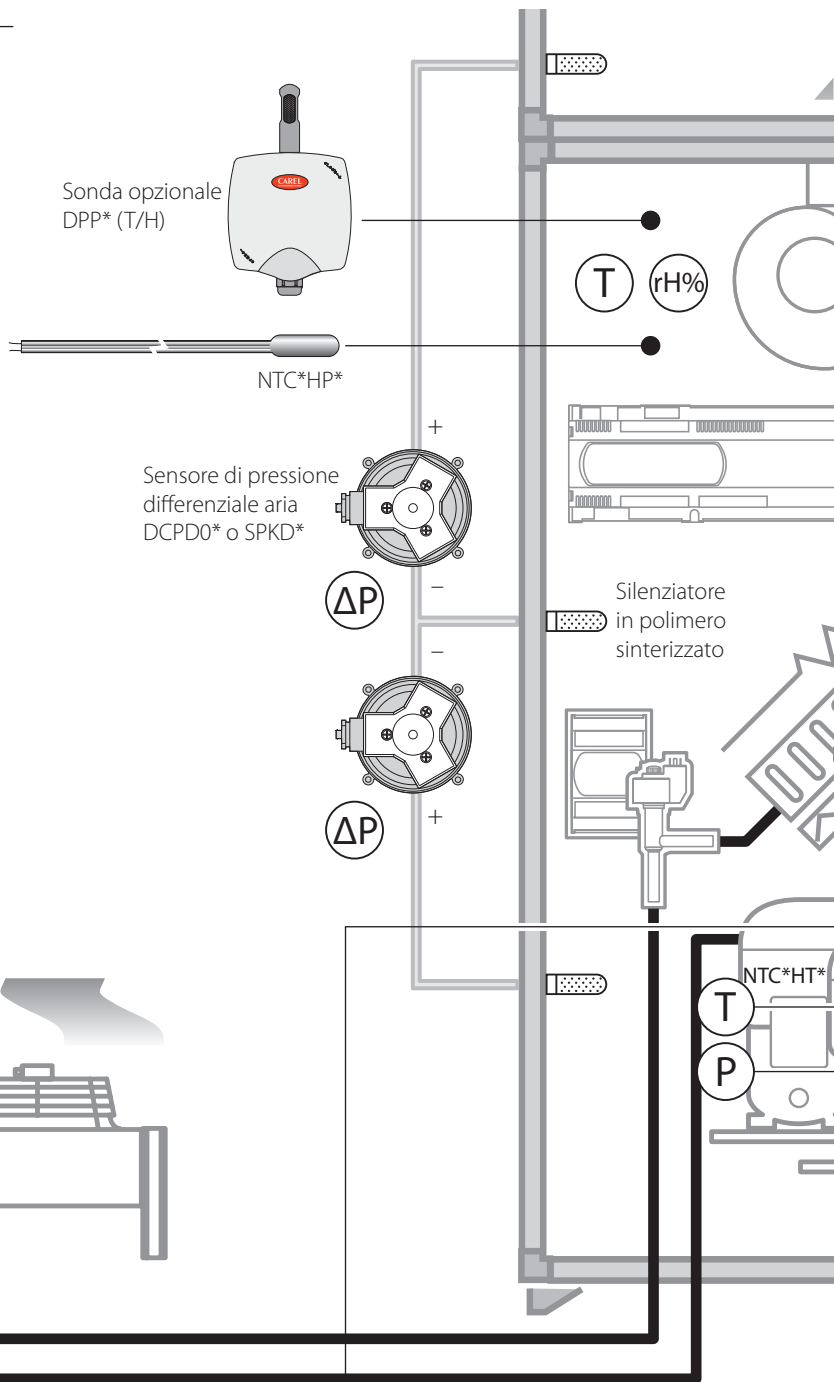
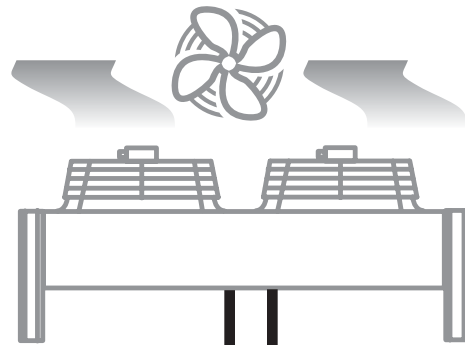

Compressore BLDC

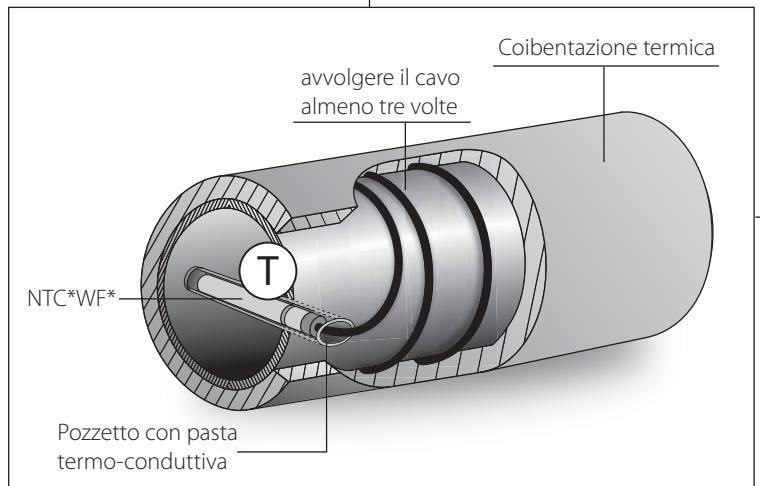
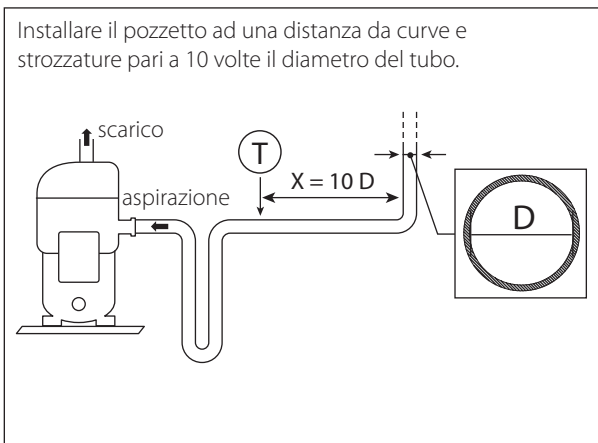

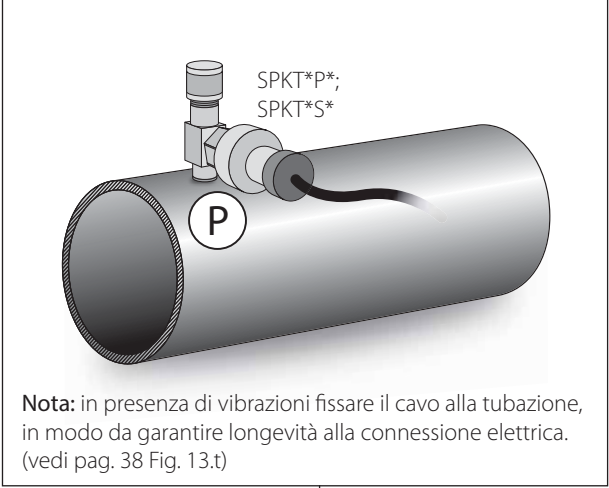
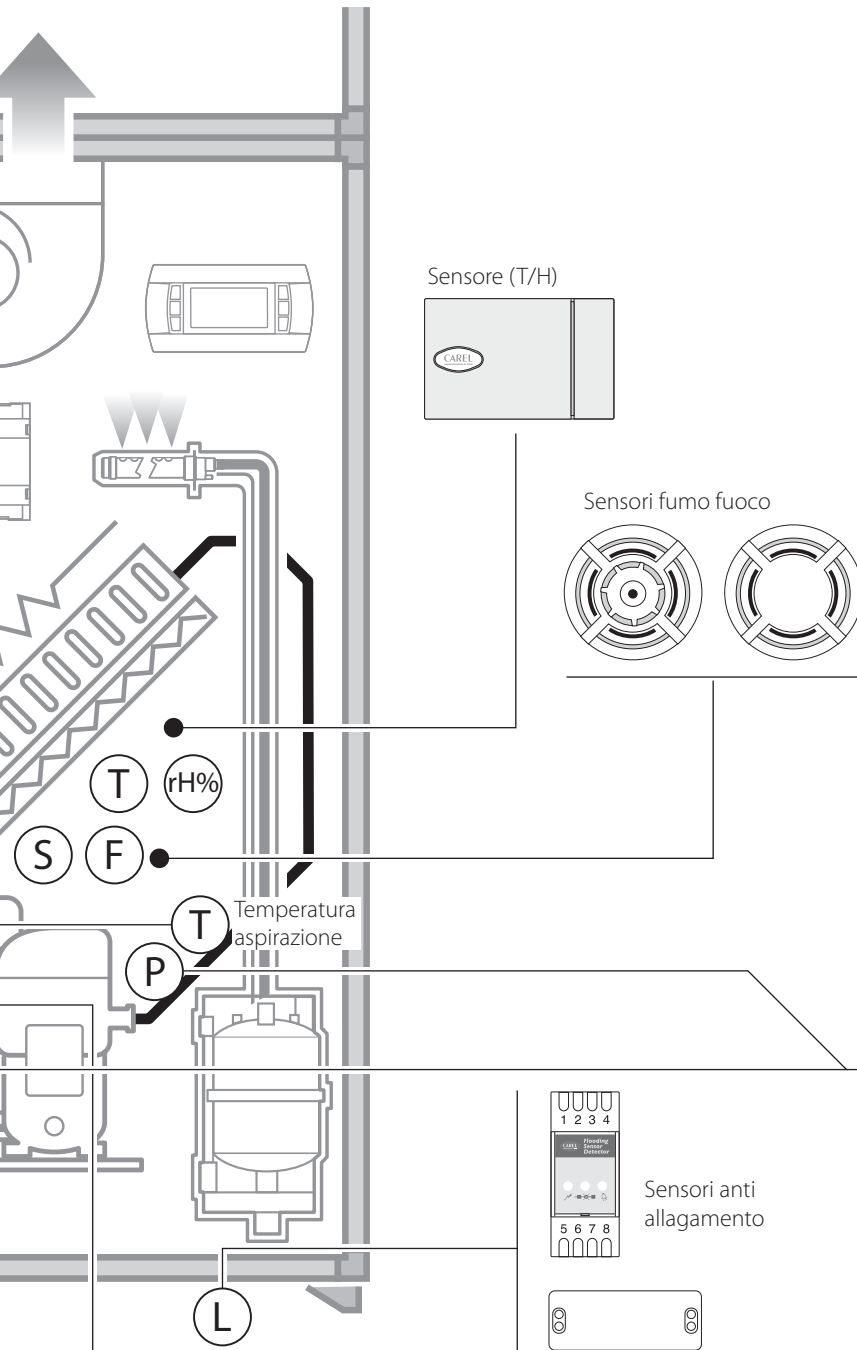

Nota: in presenza di vibrazioni fissare il cavo alla tubazione, in modo da garantire longevità alla connessione elettrica. (vedi pag. 38 Fig. 13.t)

Collegamento con capillare

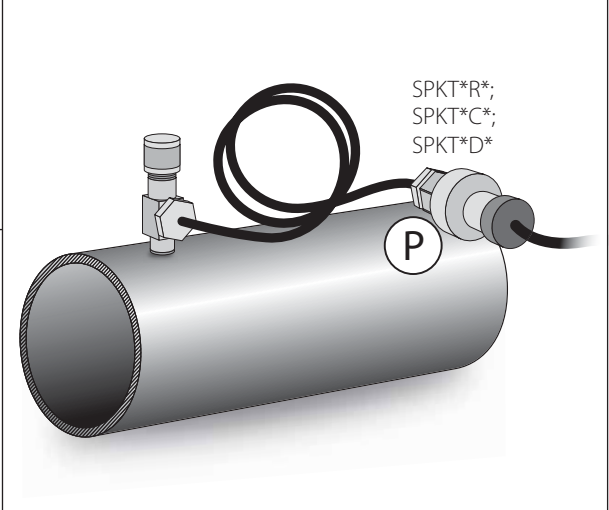

Collegamento a saldare

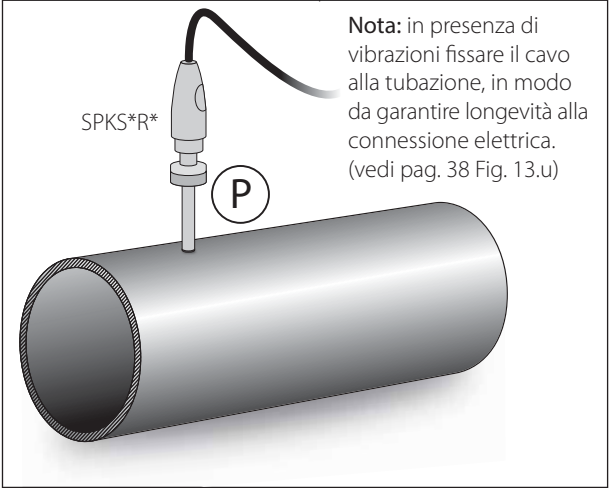

Nota: in presenza di vibrazioni fissare il cavo alla tubazione, in modo da garantire longevità alla connessione elettrica. (vedi pag. 38 Fig. 13.u)

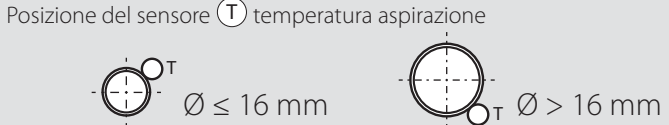
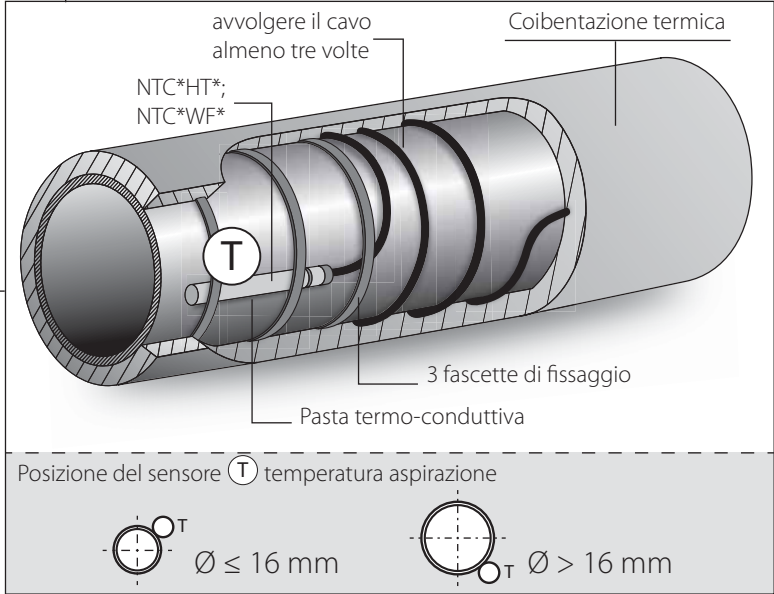

12.4 CRAC CW

LEGENDA

T	Temperatura
rH%	Umidità relativa
ΔP	Differenziale di pressione
S	Fumo
F	Fuoco
L	Sensore anti allagamento

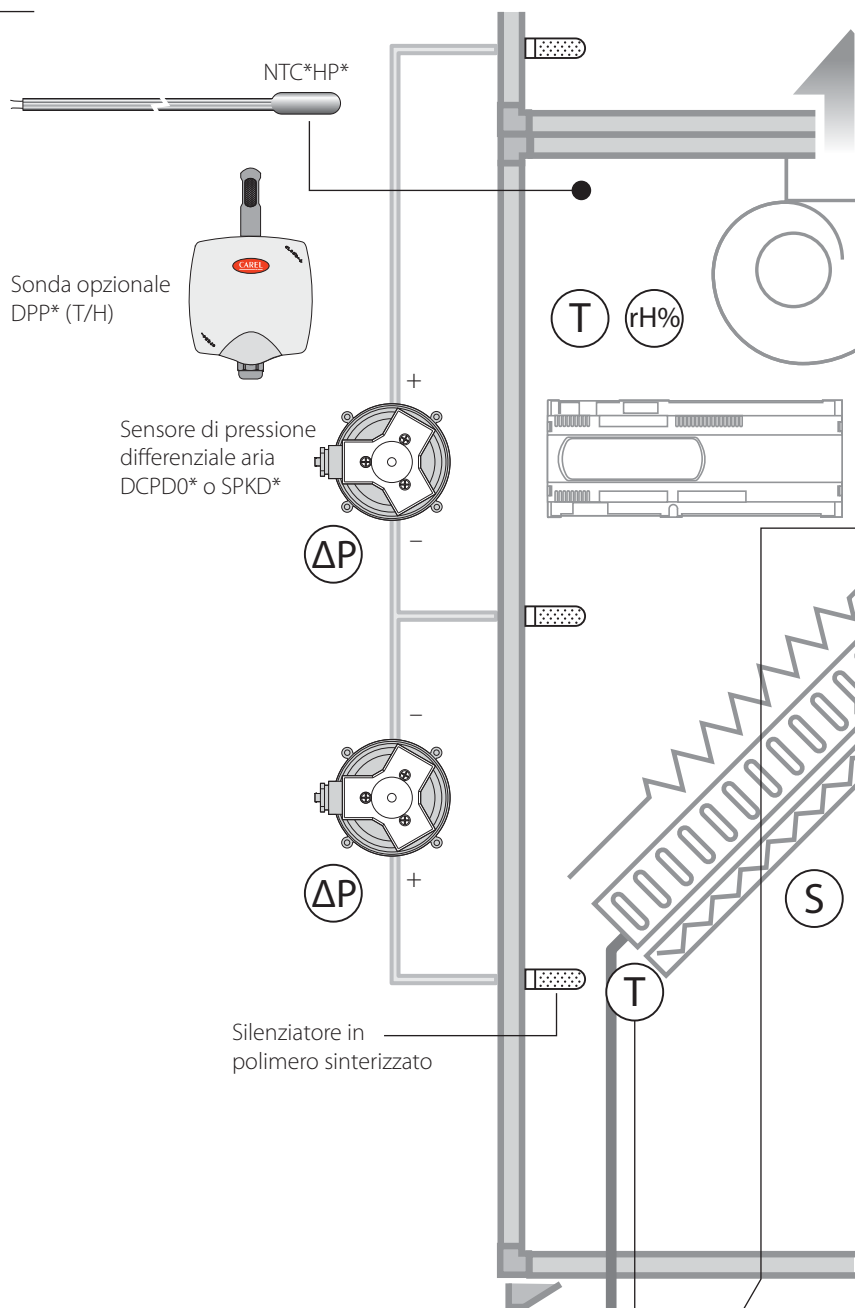

Sonda di regolazione

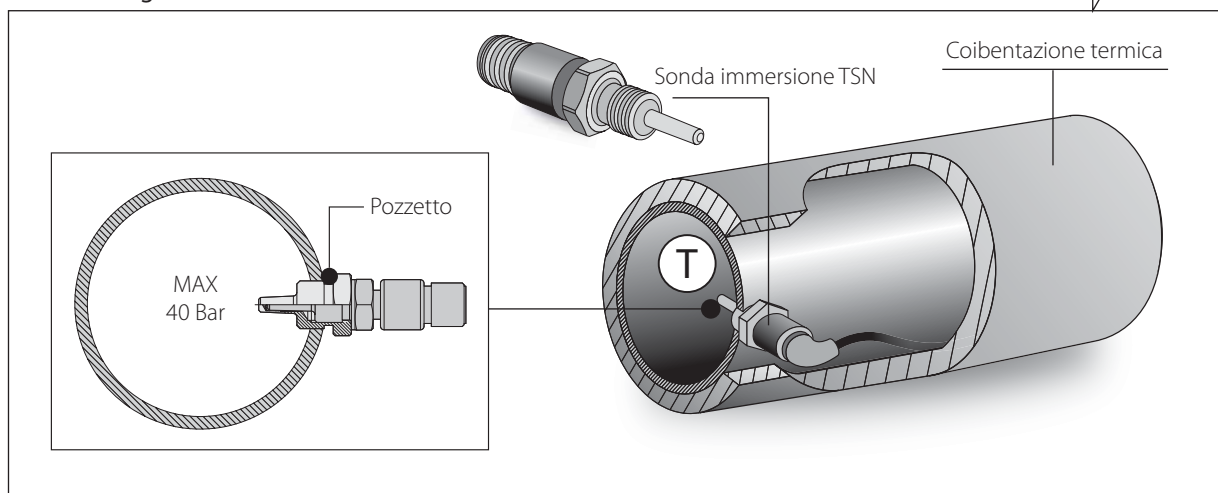

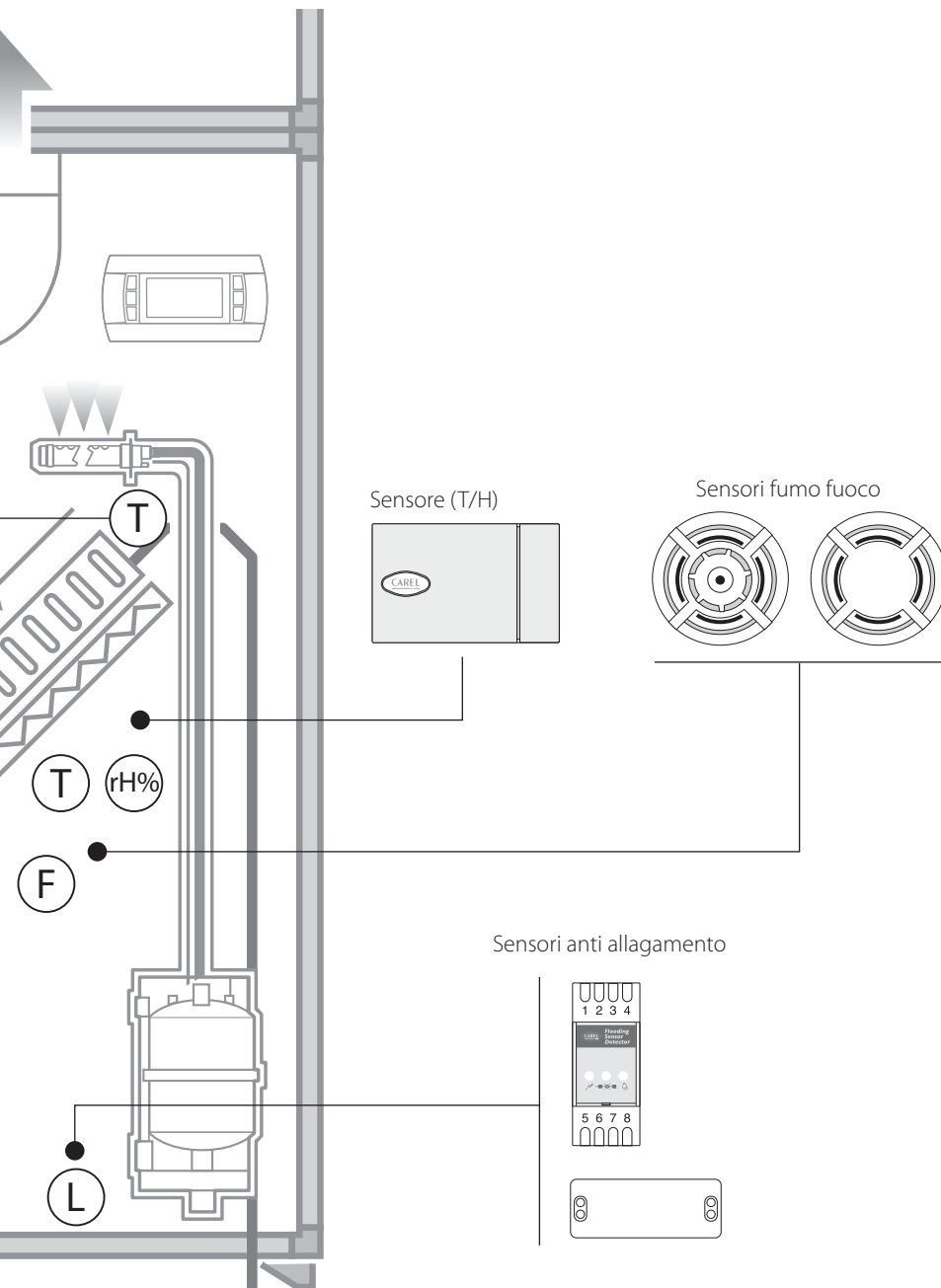

1ª soluzione alternativa - Sonda di lettura

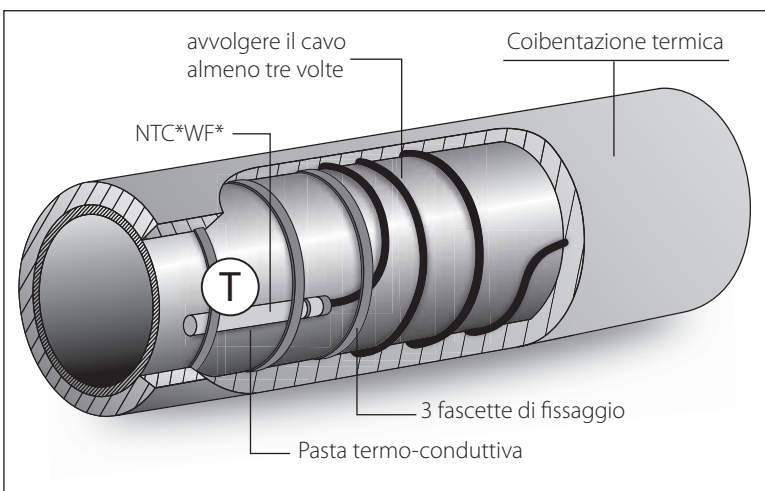

2ª soluzione alternativa - Sonda di lettura

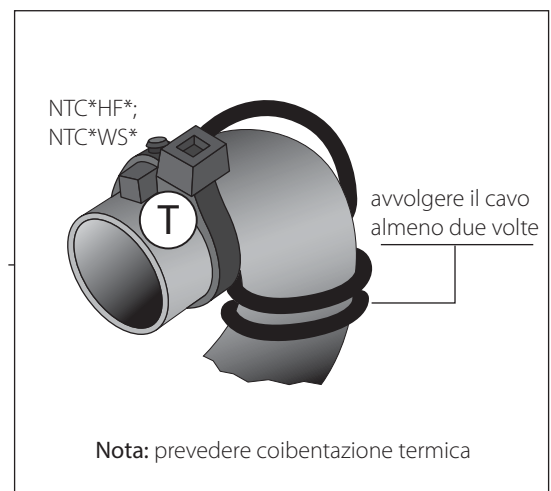

12.5 HVAC: Applicazione raffreddamento tecnologico/di processo Chiller condensati ad aria/acqua

LEGENDA

(T)	Temperatura
(P)	Pressione

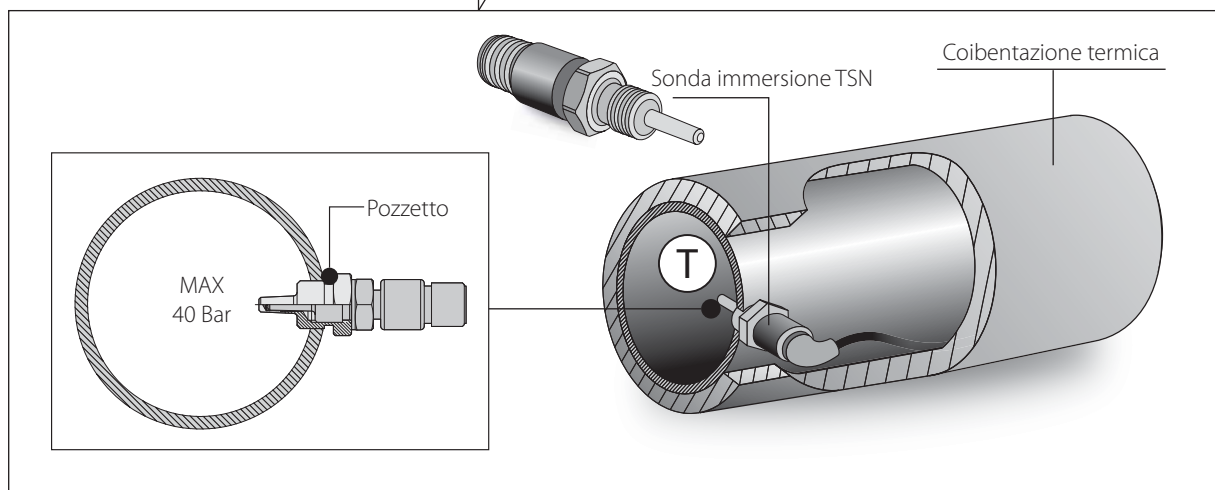
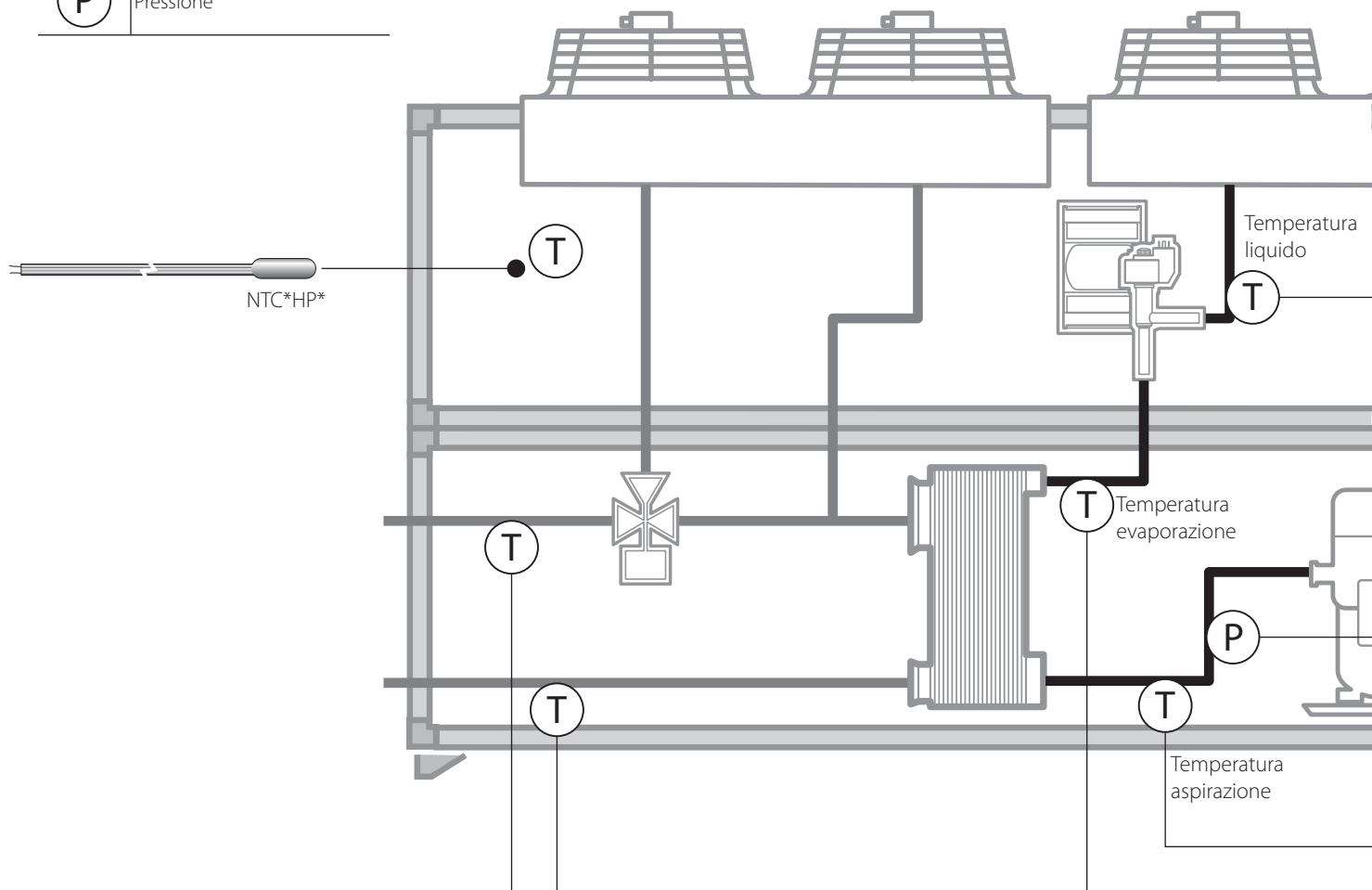

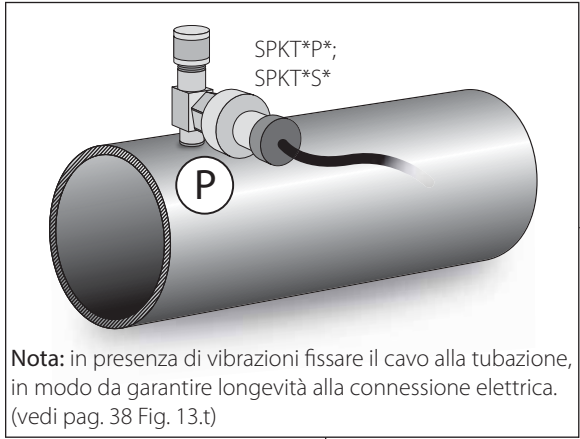

Collegamento con capillare

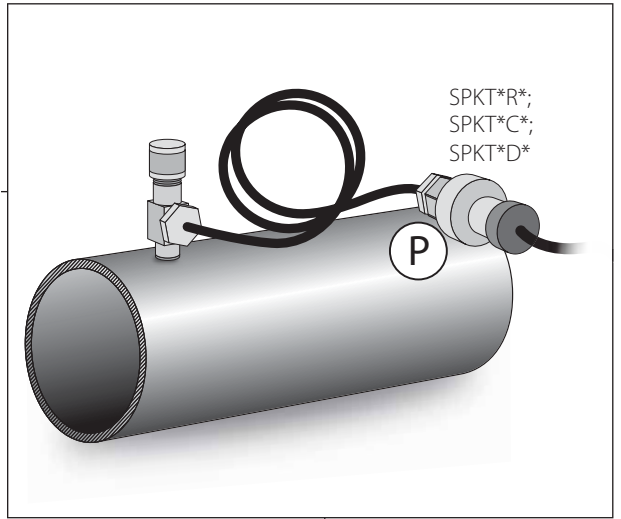

Collegamento a saldare

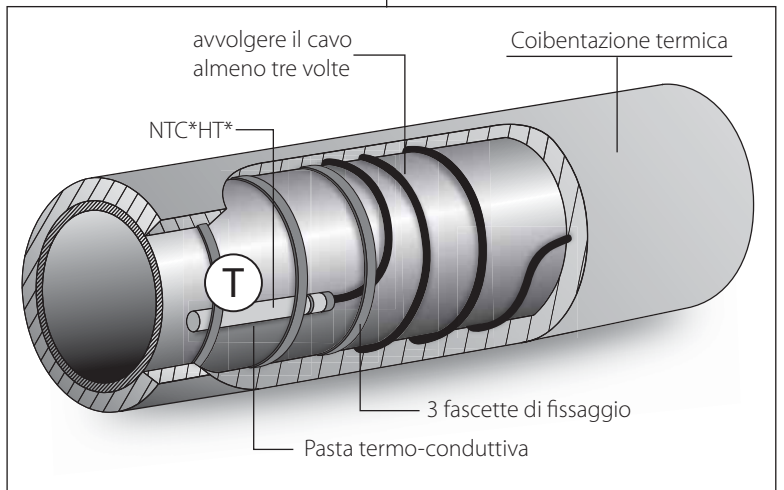
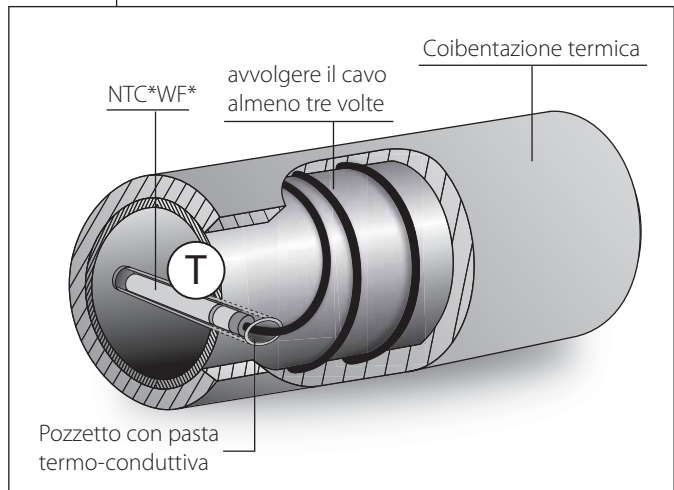
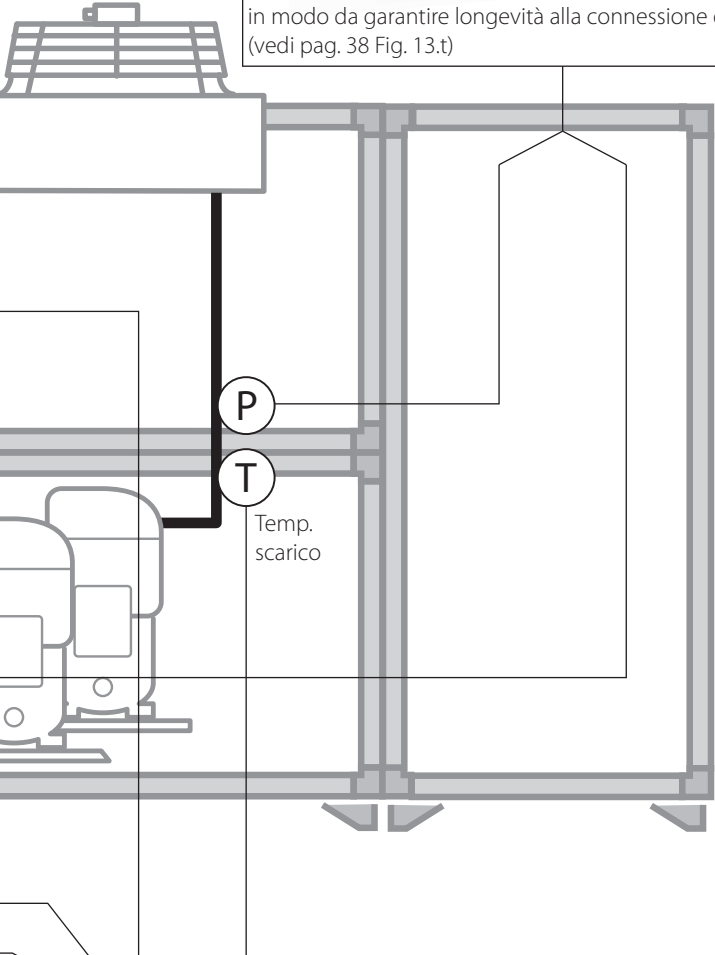
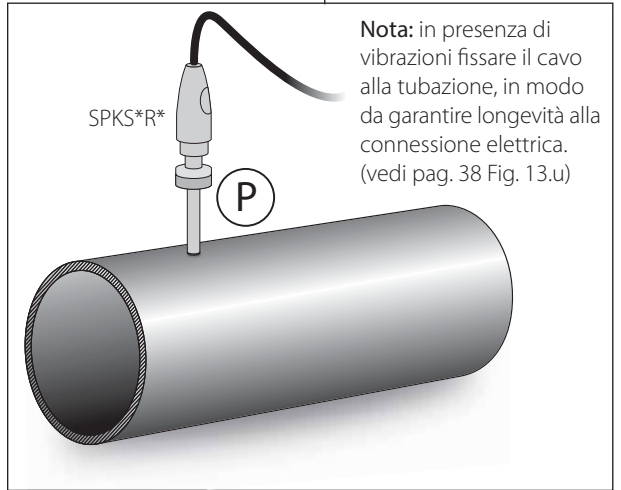

12.6 HVAC: Applicazioni commerciali/residenziali - Roof Top

LEGENDA

T	Temperatura
P	Pressione
rH%	Umidità relativa
ΔP	Differenziale di pressione

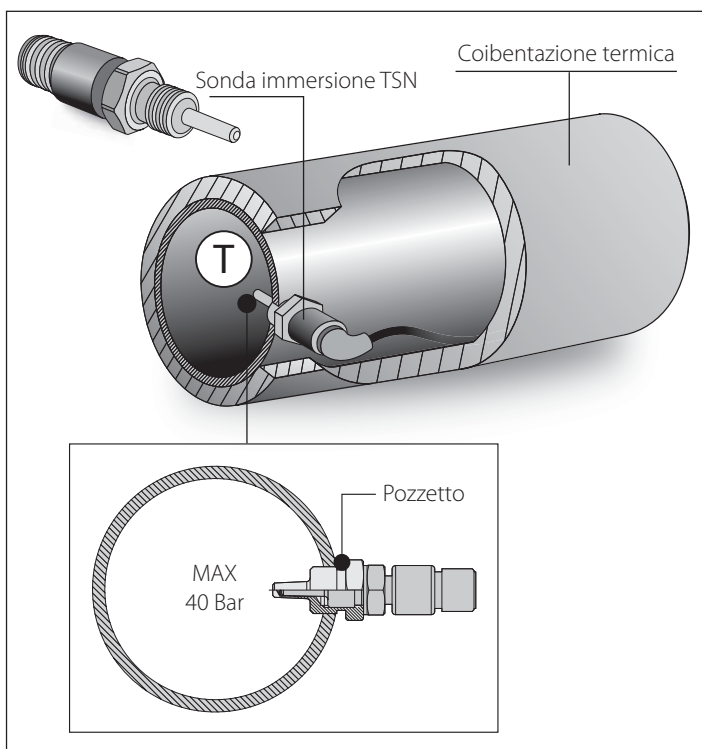
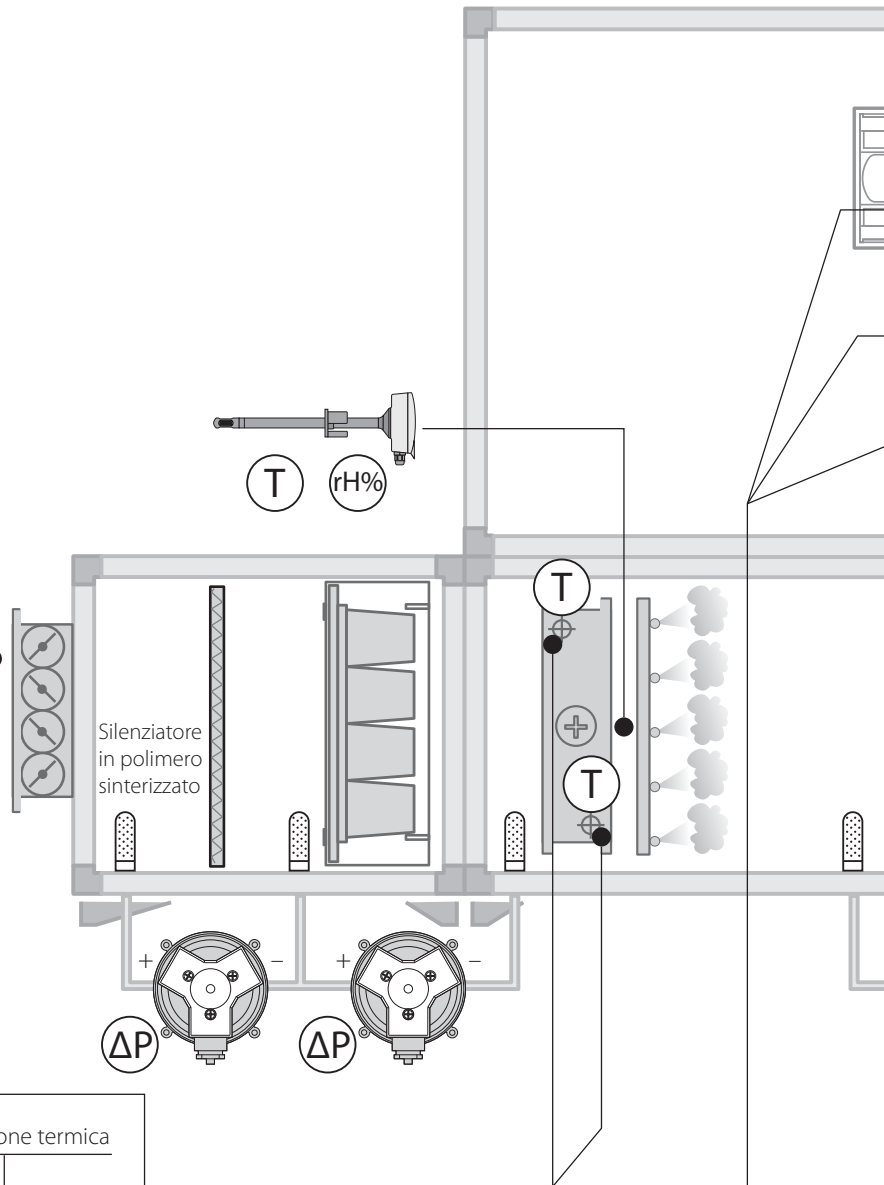
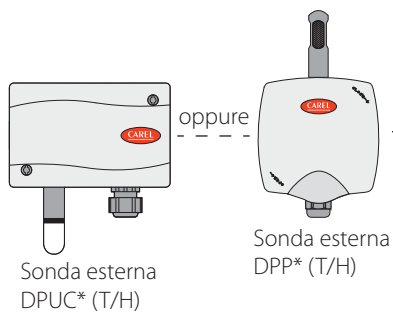

Compressore BLDC

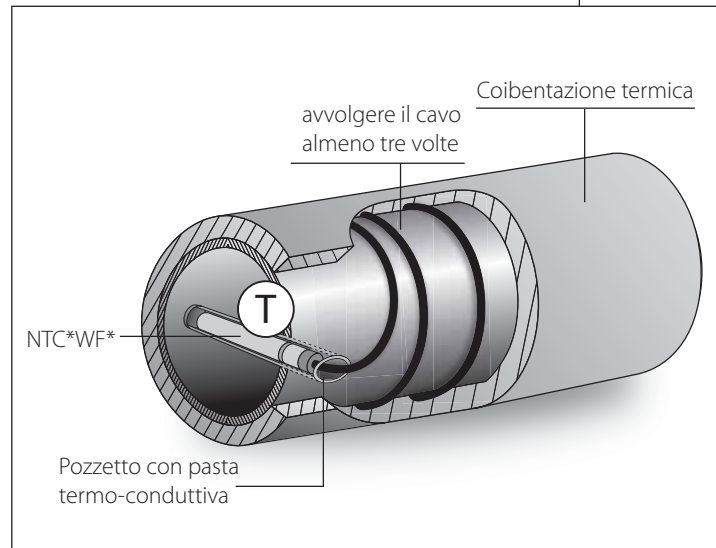

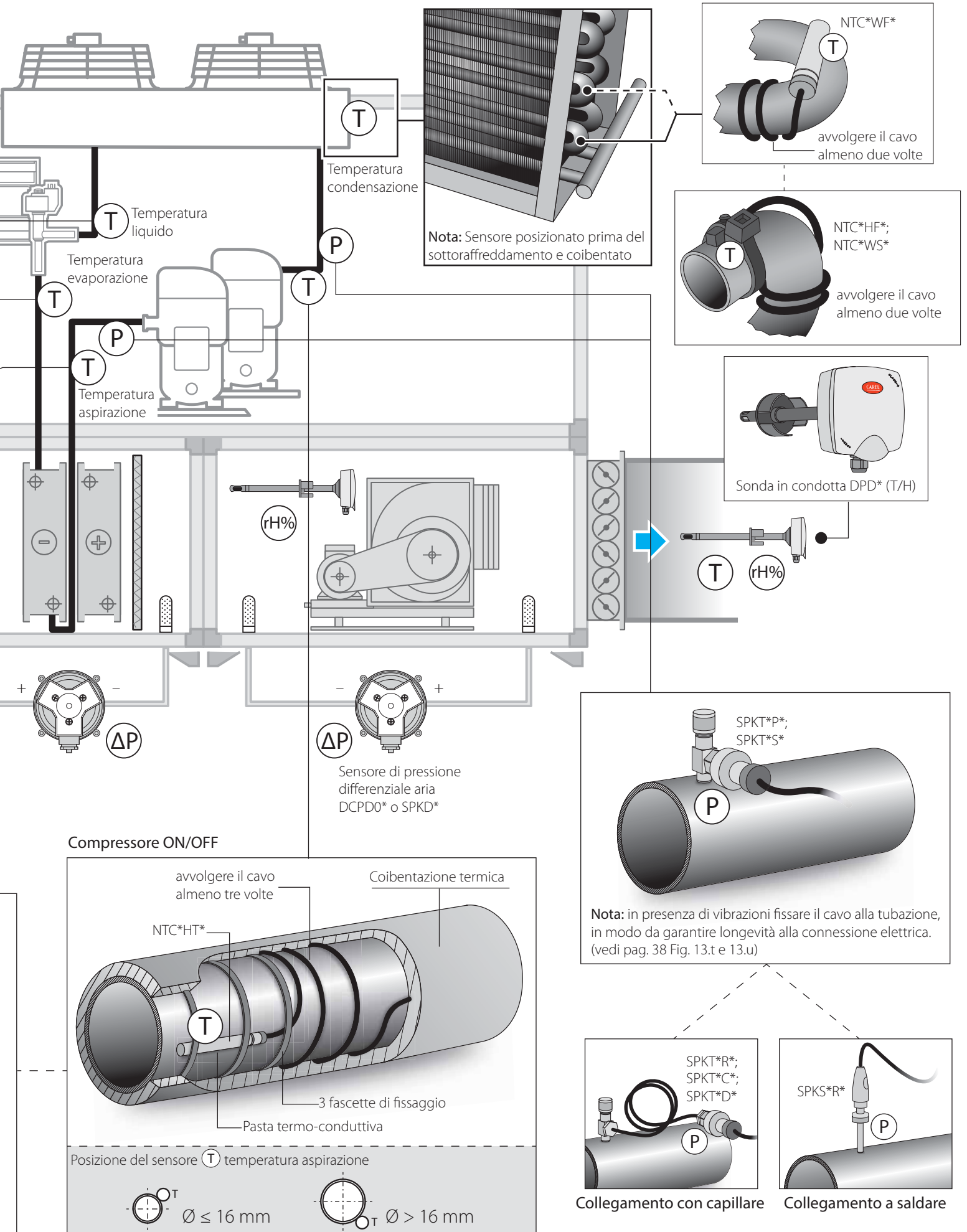

12.7 Abbattitore

LEGENDA

T	Temperatura
P	Pressione
rH%	Umidità relativa

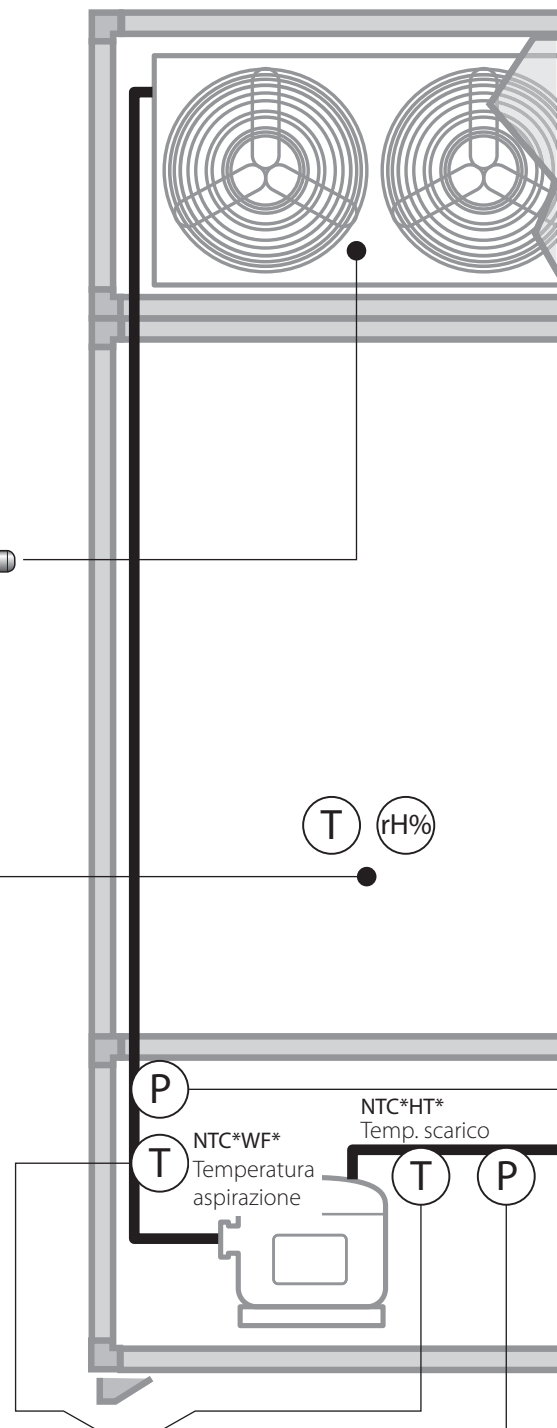
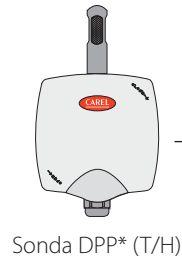
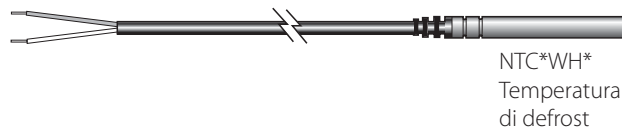

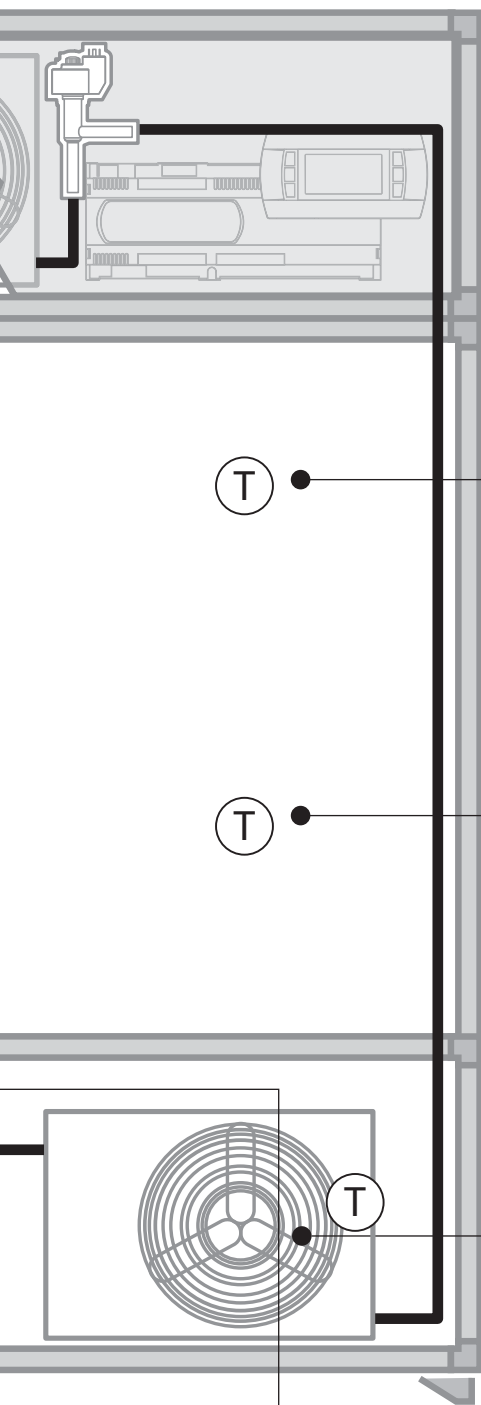

Sonda infilzaggio NTCINF610*
Temperatura prodotto

T

NTC*HP*;
NTC*HF*;
NTC*WS*

T

Temperatura cella

Temperatura
condensazione

T

Collegamento a saldare

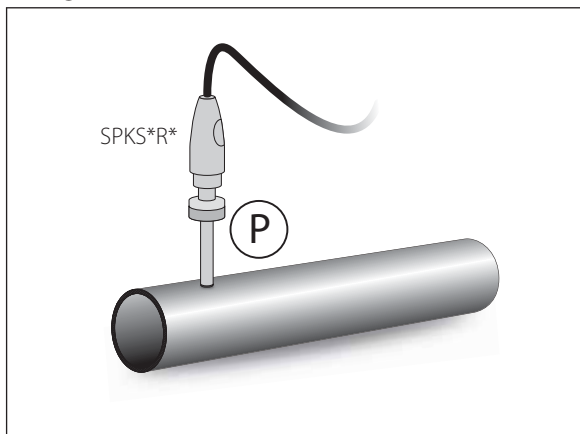

Collegamento con capillare

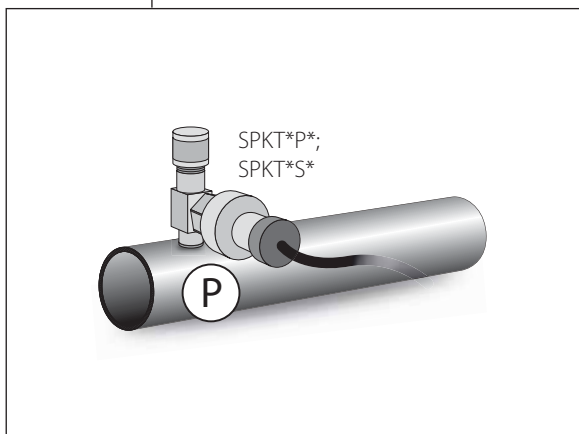
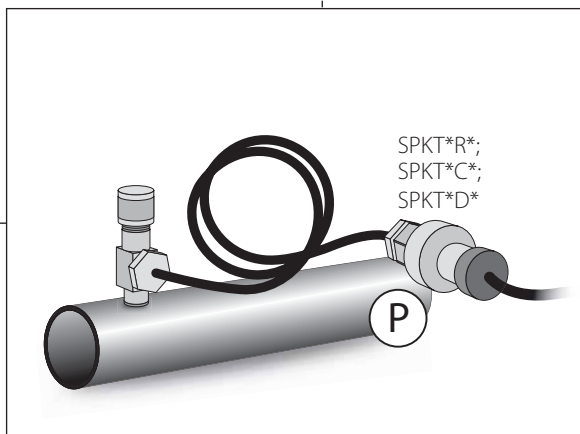

12.8 Banchi frigo autonomi/Refrigeratore di bevande

LEGENDA

T	Temperatura
P	Pressione

Collegamento a saldare

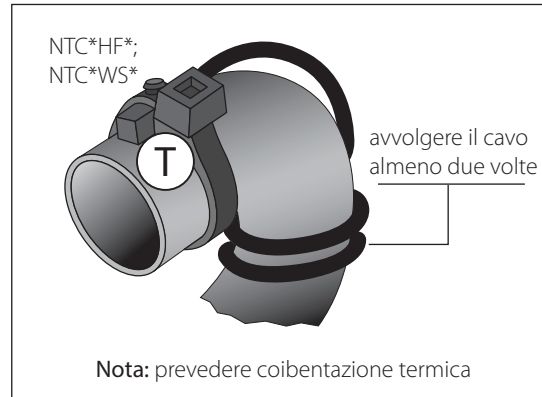
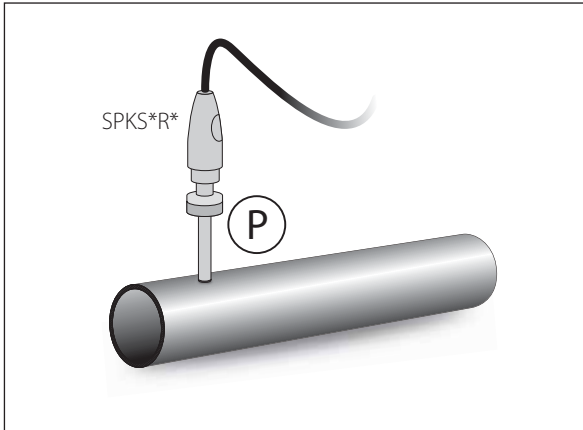

Collegamento con capillare

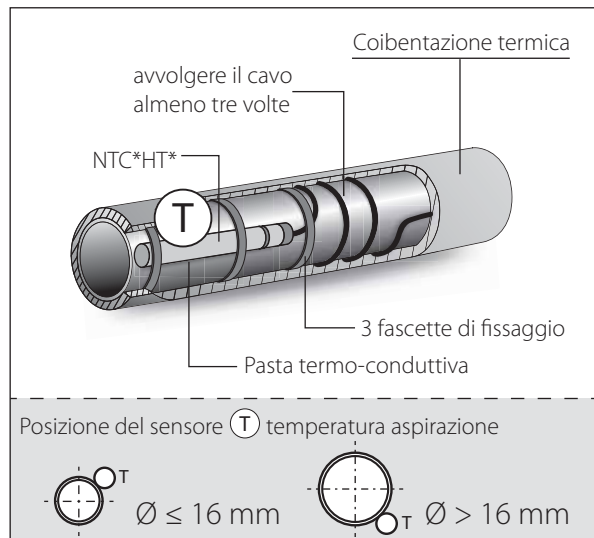
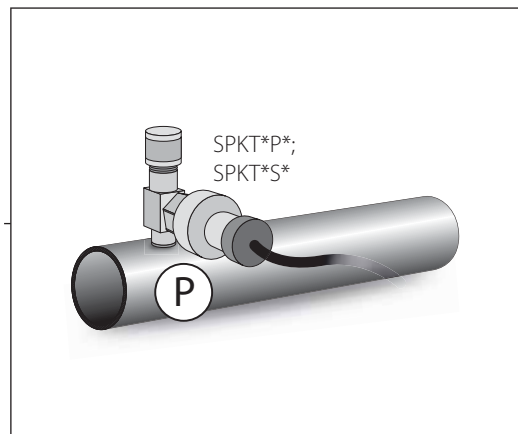
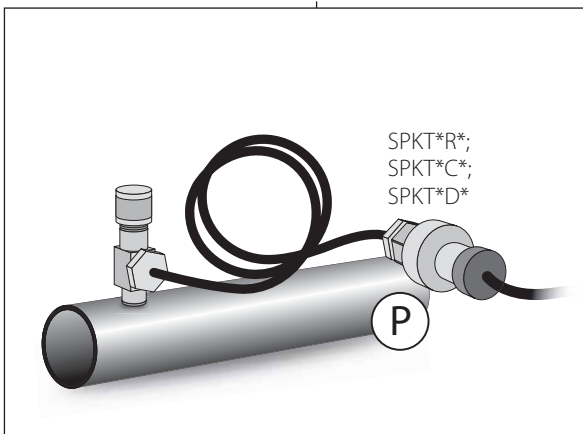

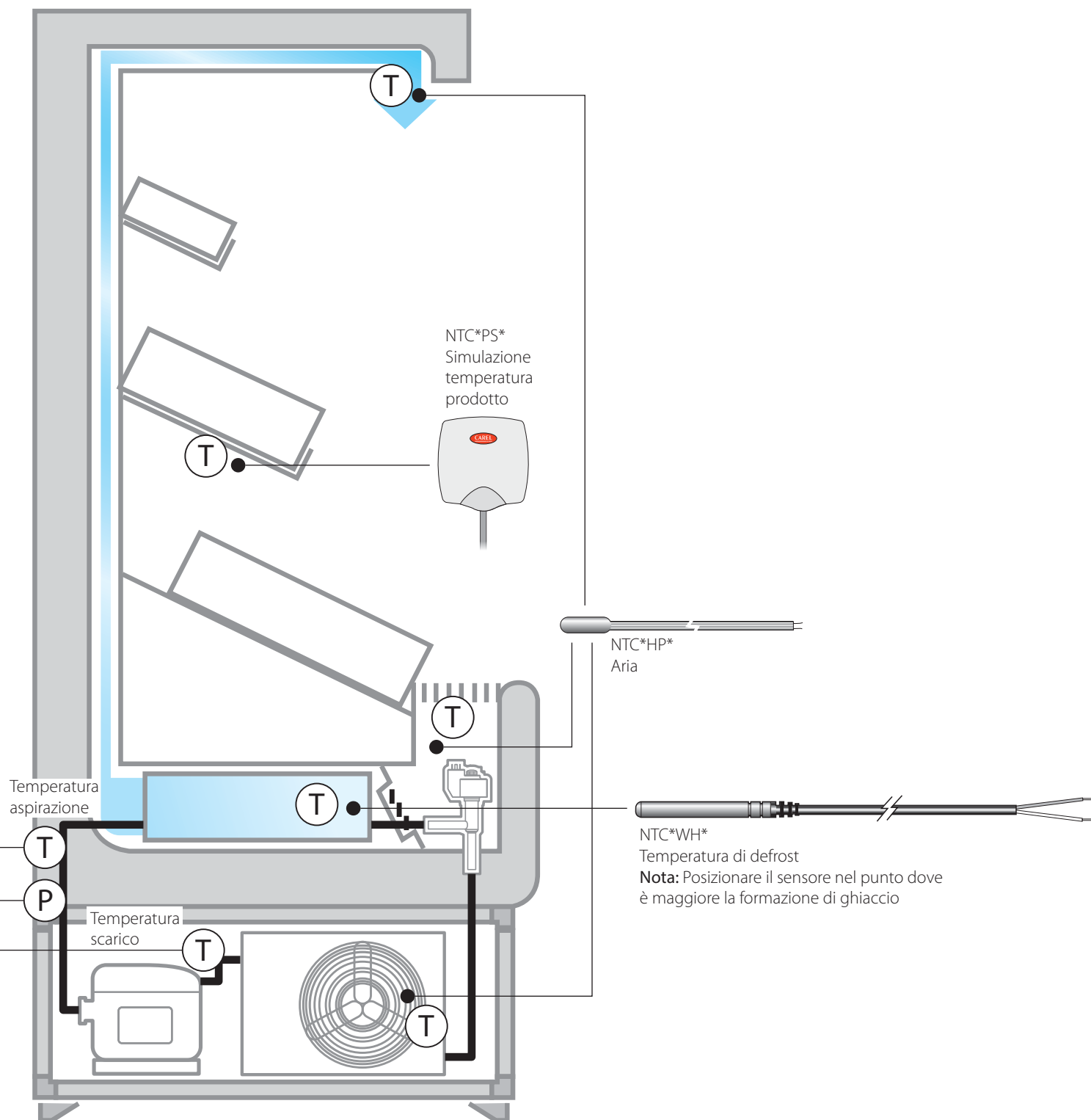

12.9 Banchi frigo autonomi condensati ad acqua

LEGENDA

T	Temperatura
rH%	Umidità relativa
P	Pressione

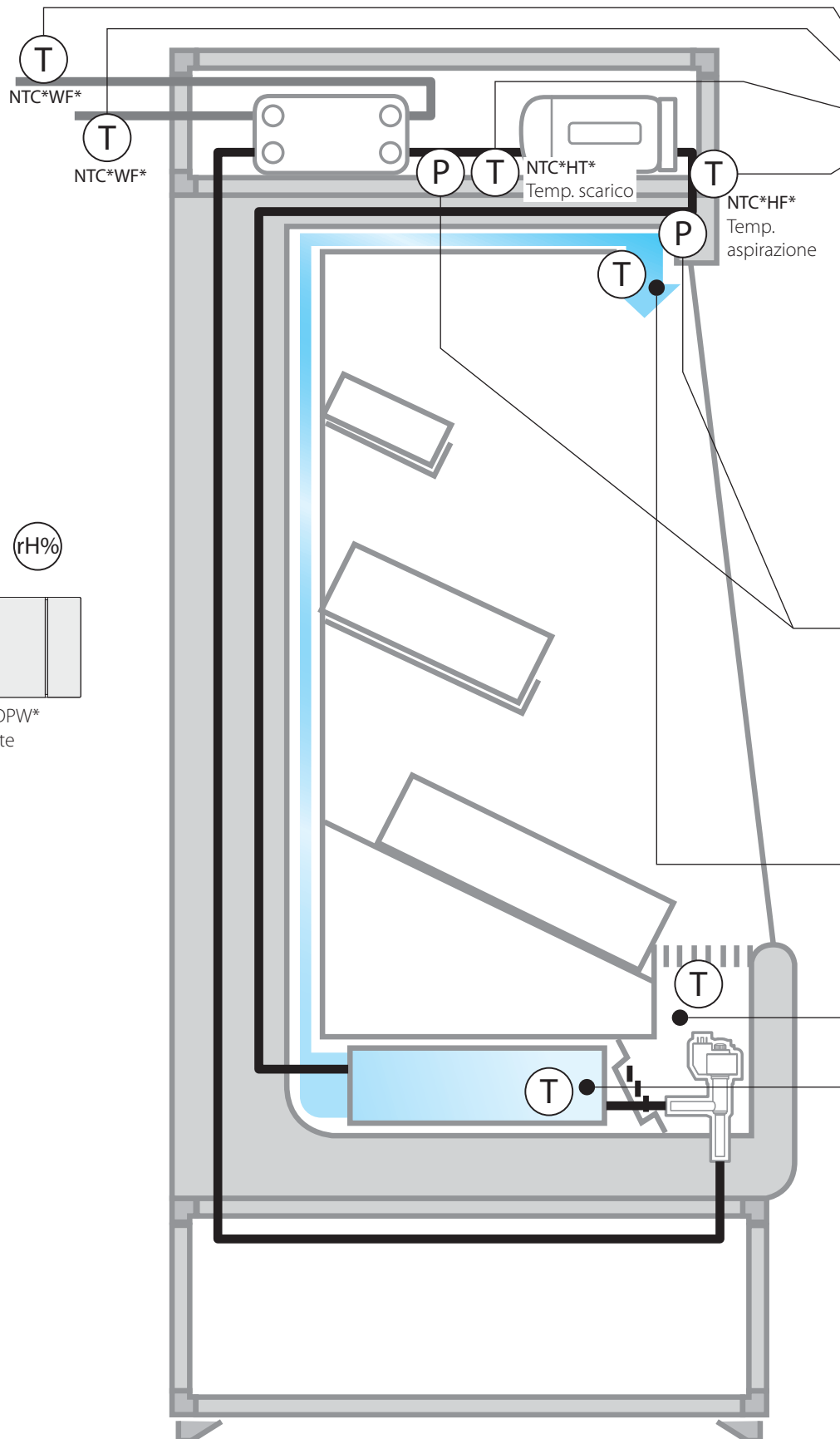
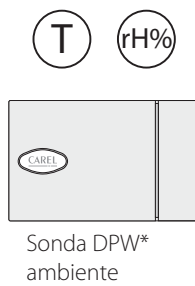

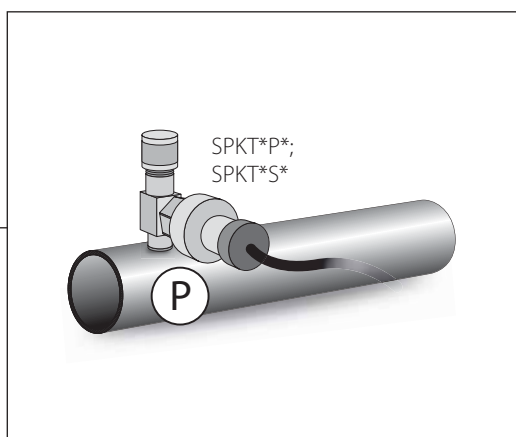
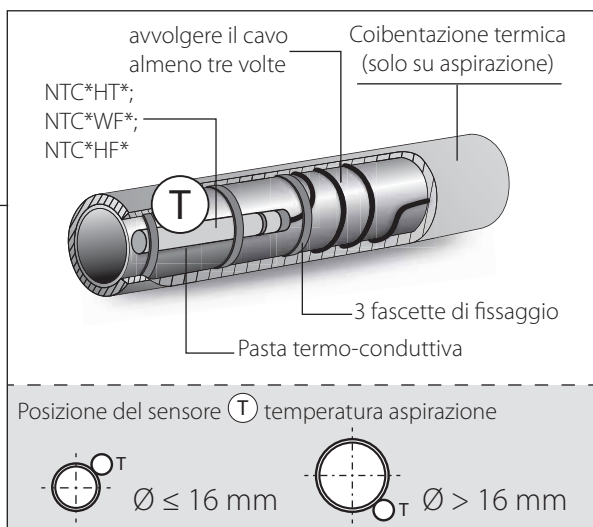

Collegamento con capillare

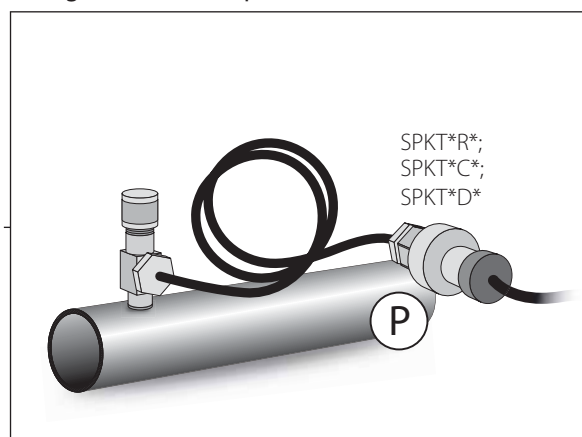

Collegamento a saldare

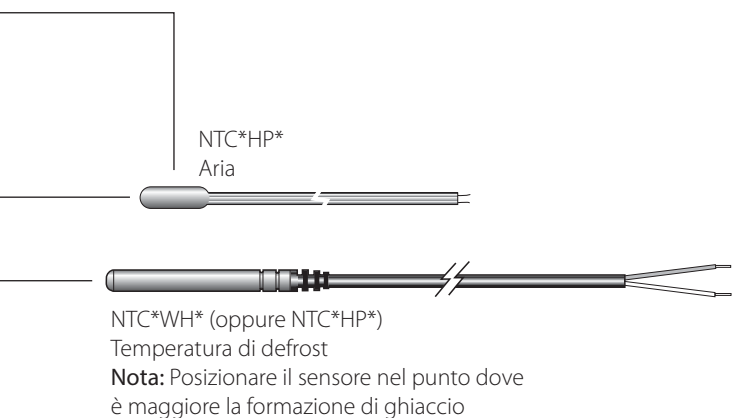
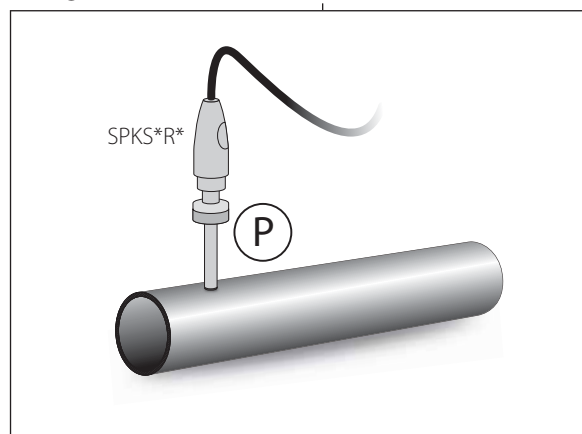

12.10 Banchi frigo centralizzati/canalizzati

LEGENDA

T	Temperatura
P	Pressione

Collegamento a saldare

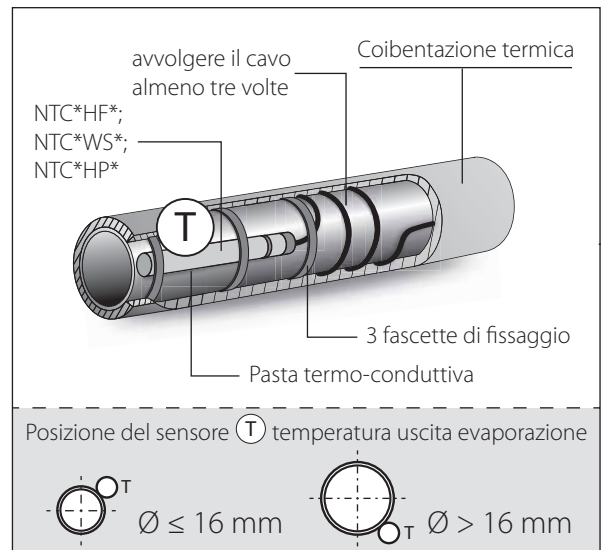
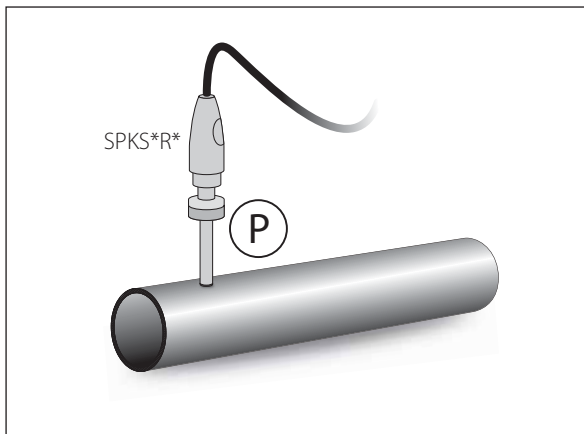

Collegamento con capillare

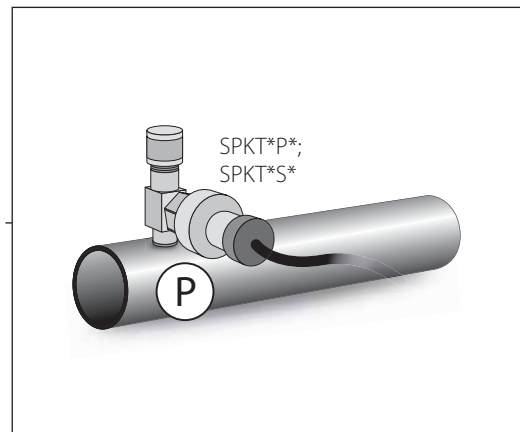
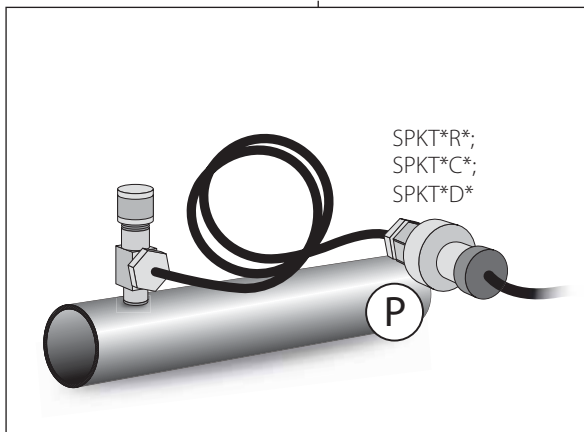

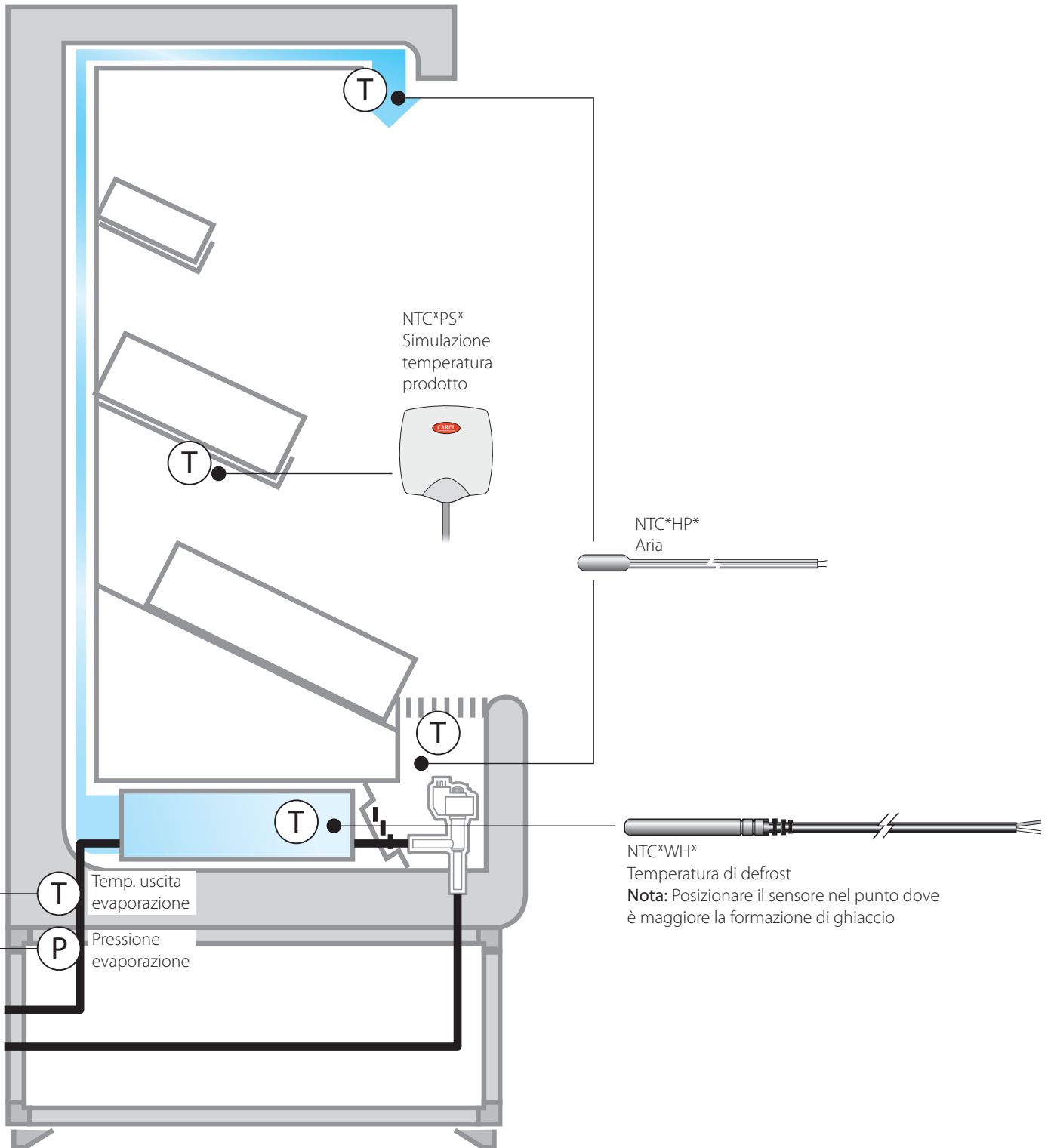

12.11 Cella frigorifera

LEGENDA

T	Temperatura
P	Pressione
rH%	Umidità relativa

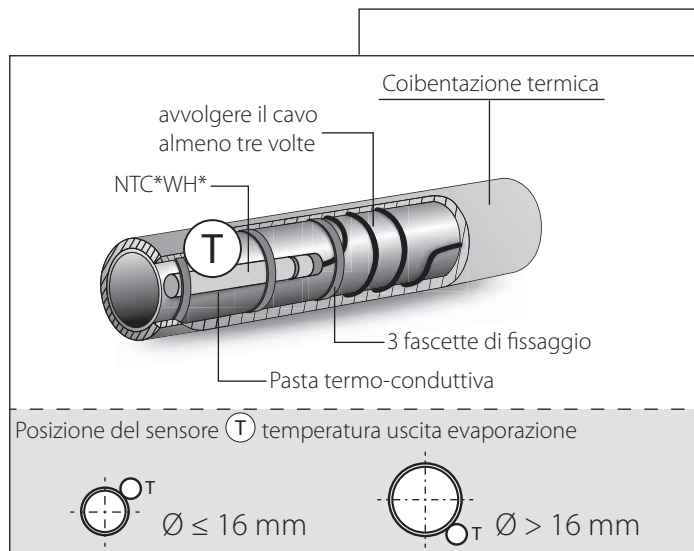
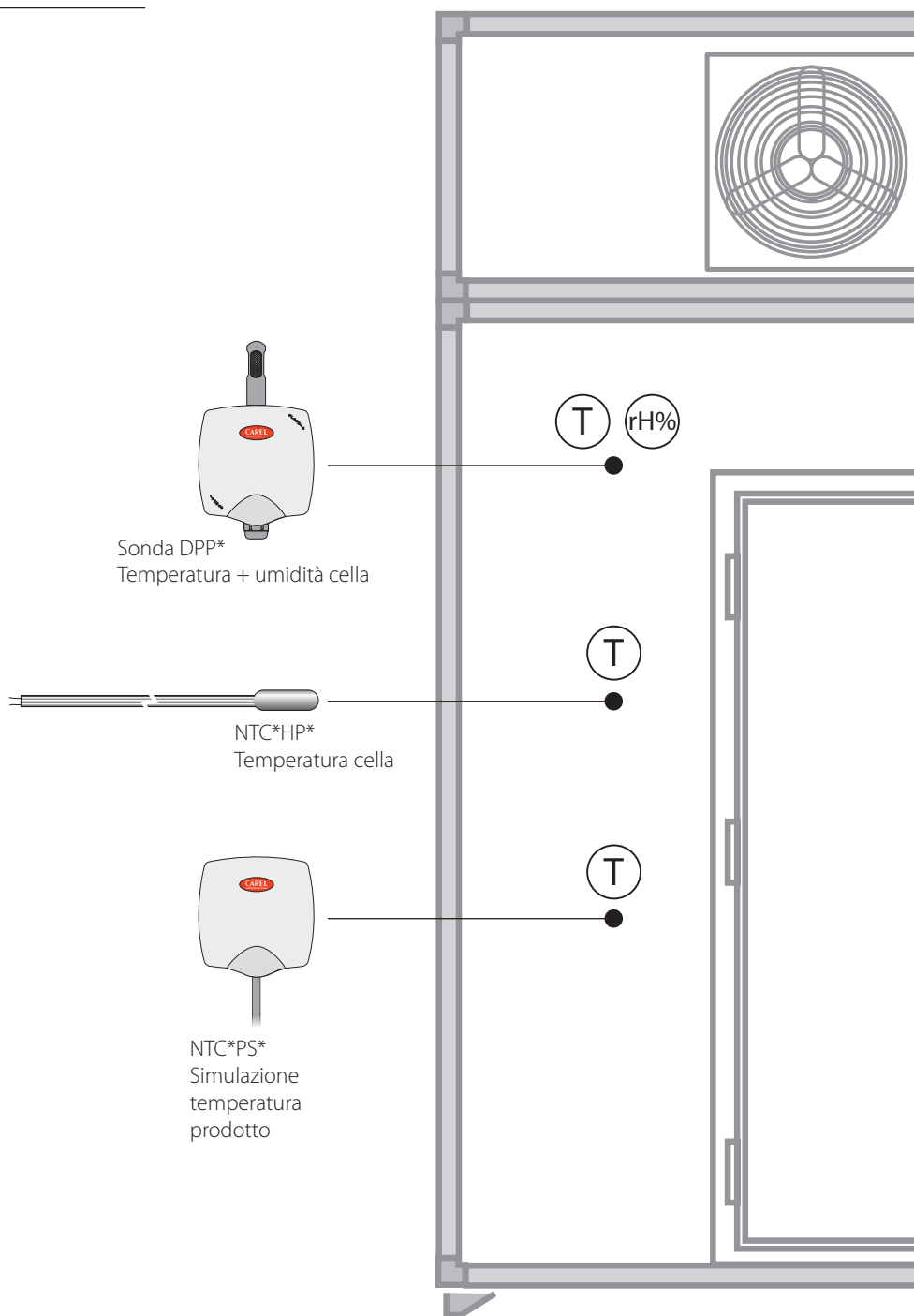

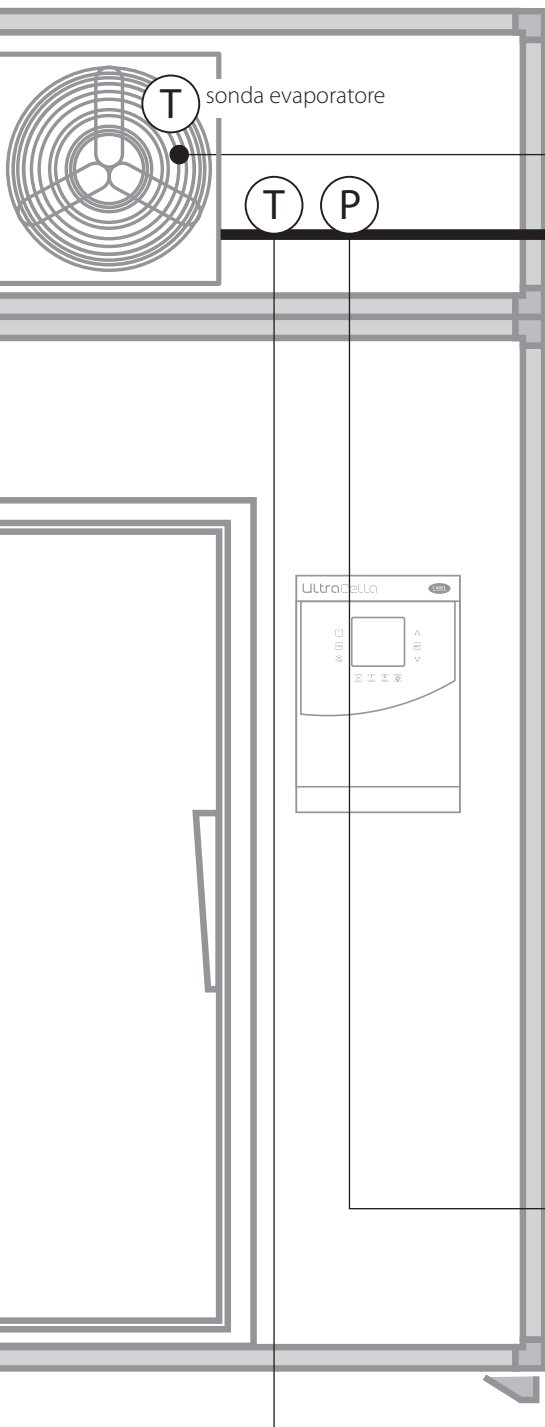

NTC*WH*

Temperatura di defrost

Nota: Posizionare il sensore nel punto dove è maggiore la formazione di ghiaccio

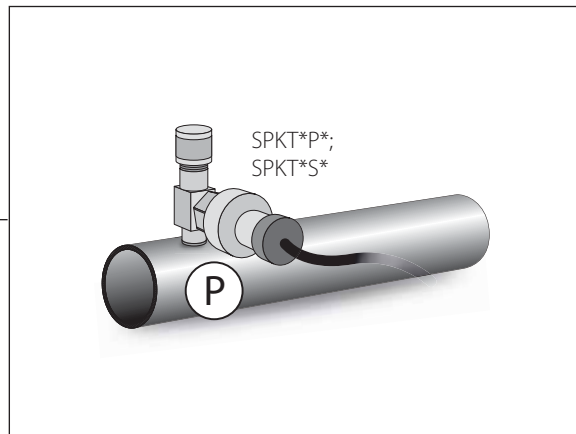
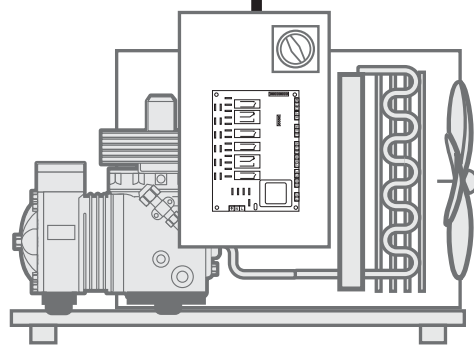

Collegamento a saldare

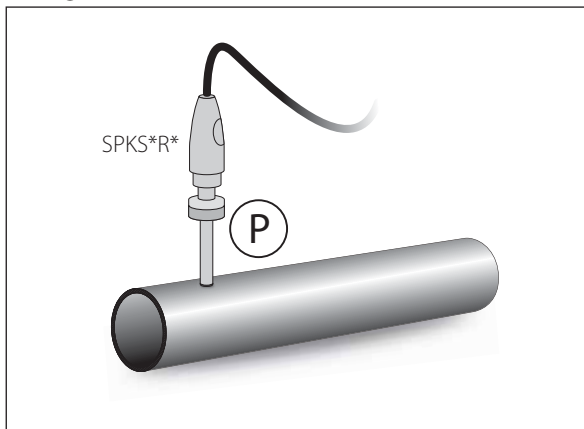

Collegamento con capillare

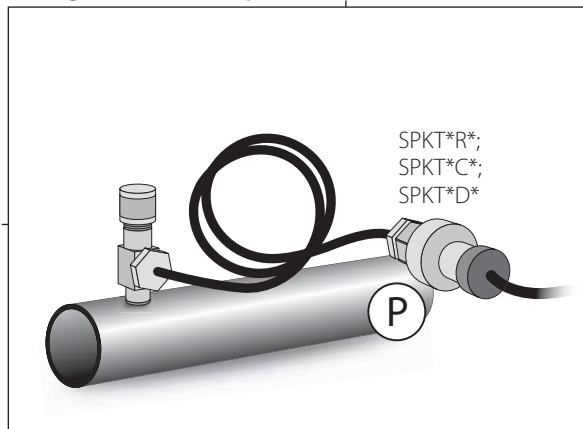

12.12 Impianto CO₂ transcritico

LEGENDA

T	Temperatura
P	Pressione

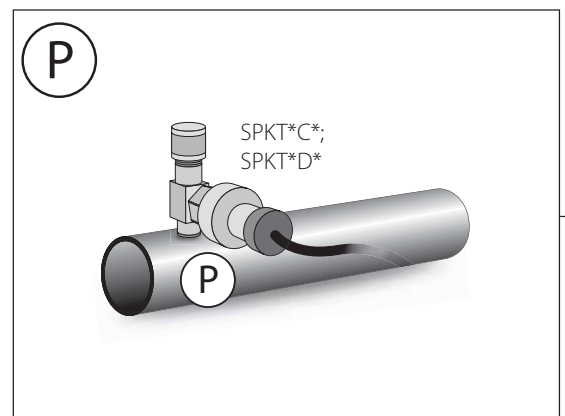
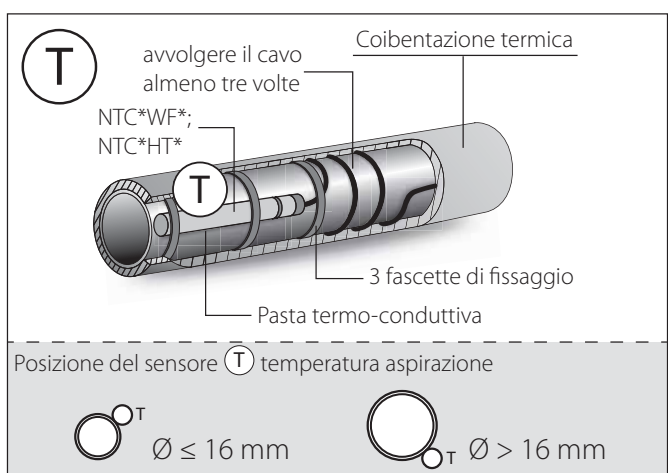
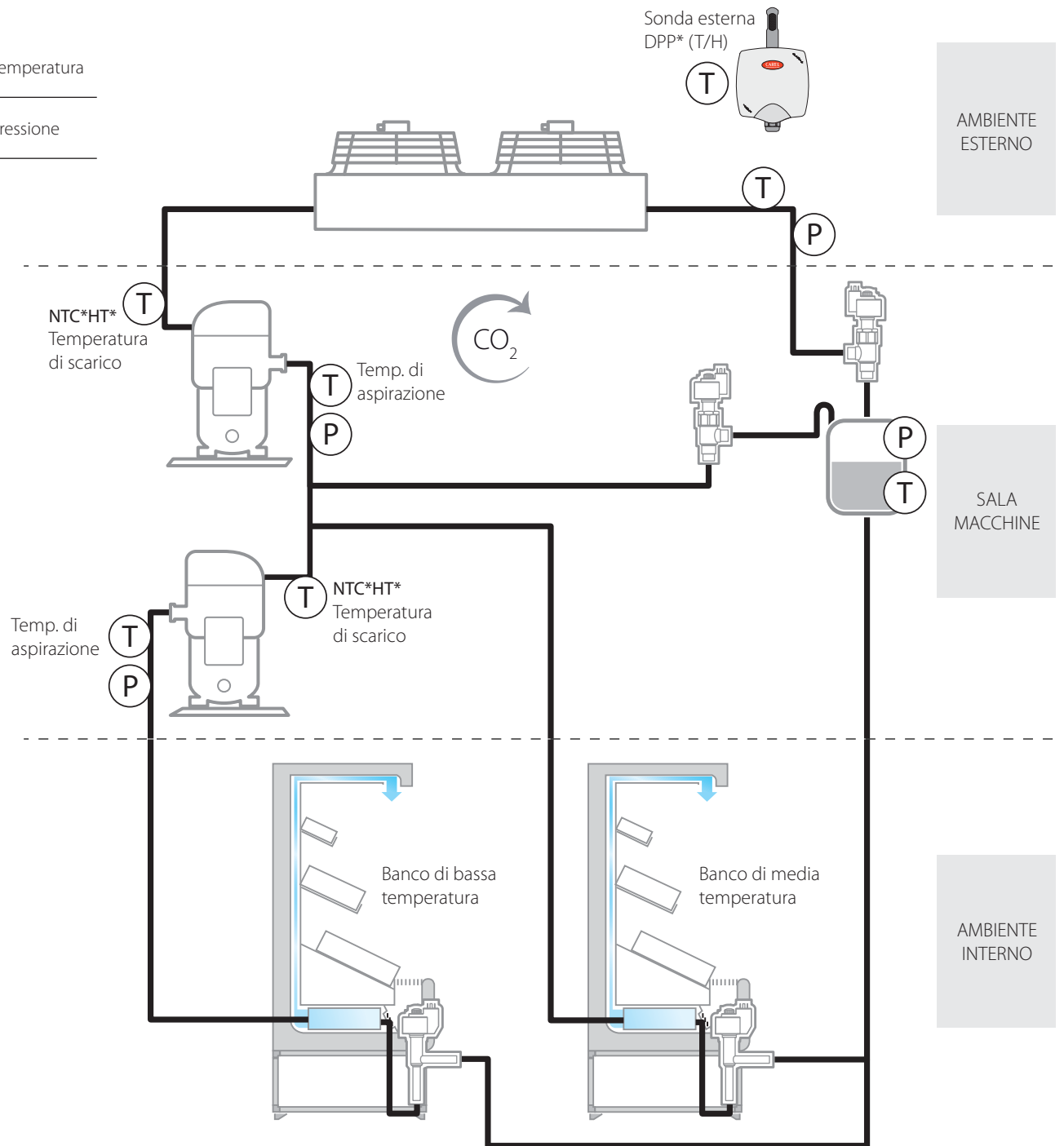

12.13 Impianto CO₂ Subcritico

LEGENDA

T	Temperatura
P	Pressione

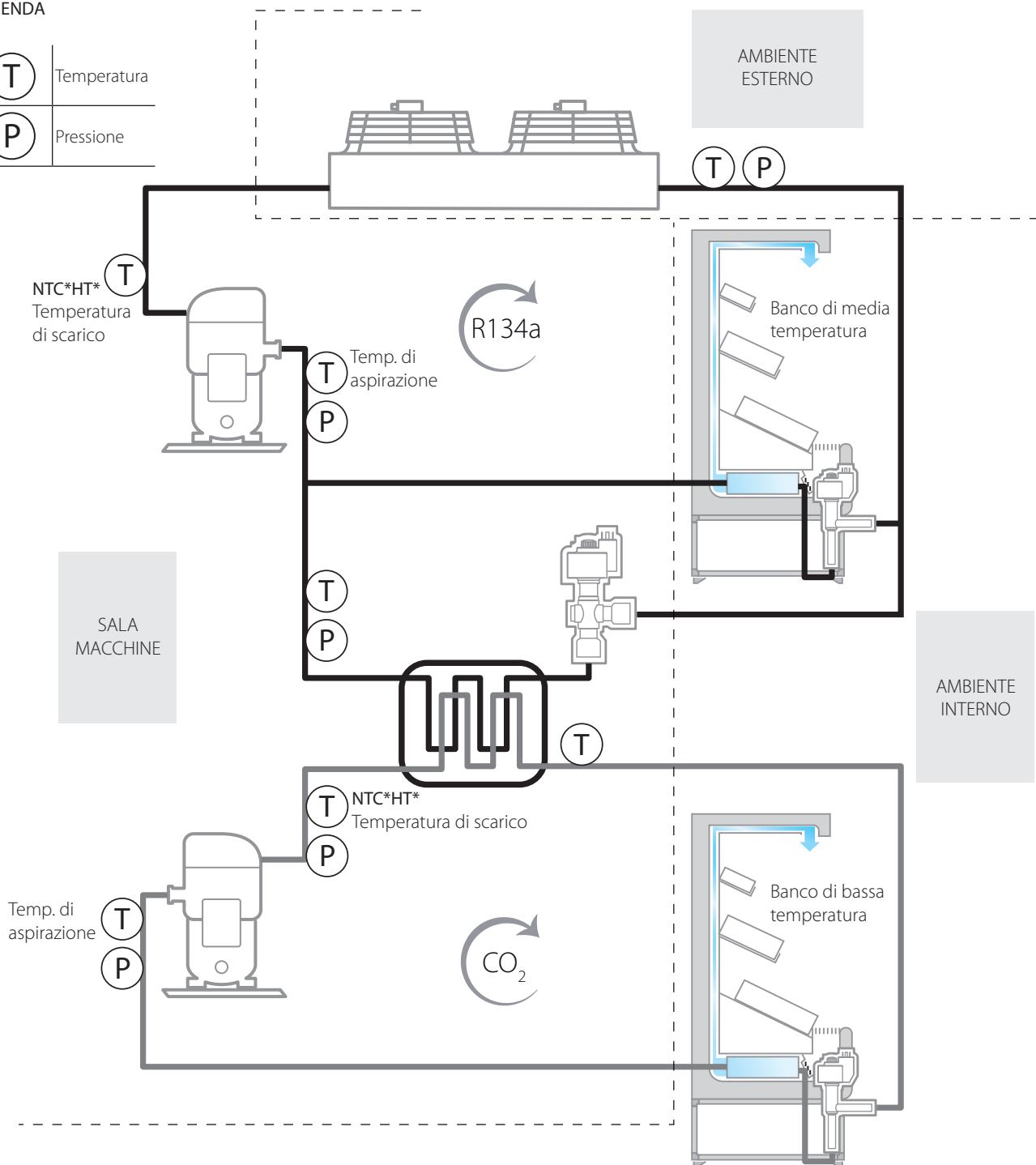

Collegamento con capillare

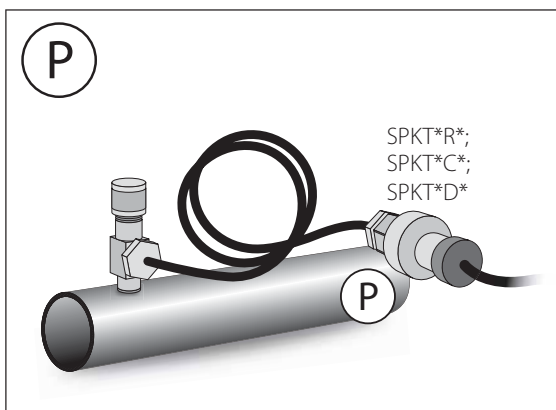

Collegamento a saldare

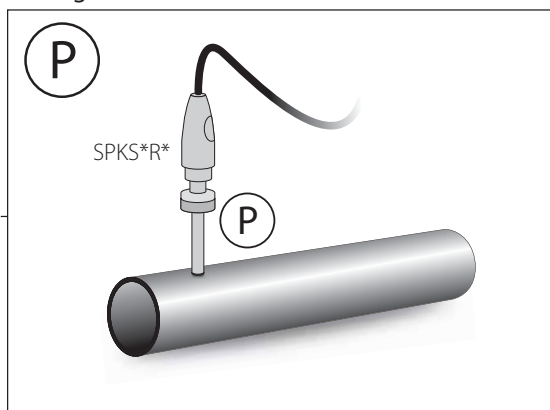

13. ULTERIORI RACCOMANDAZIONI

13.1 Sensori di temperatura e umidità ambiente

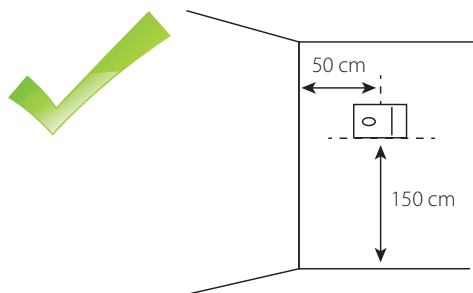

Fig. 13.a

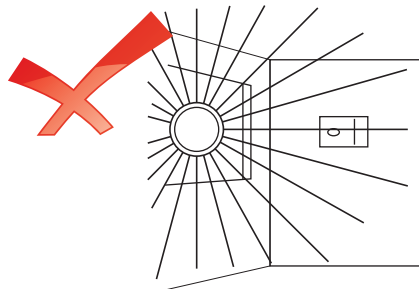

Fig. 13.b

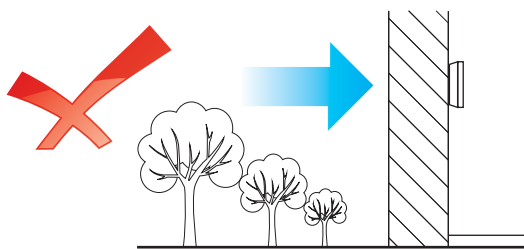

Fig. 13.c

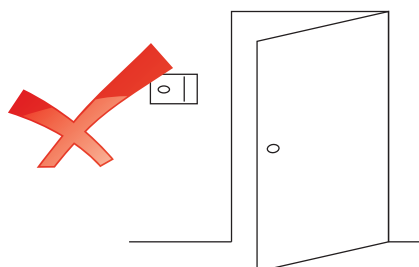

Fig. 13.d

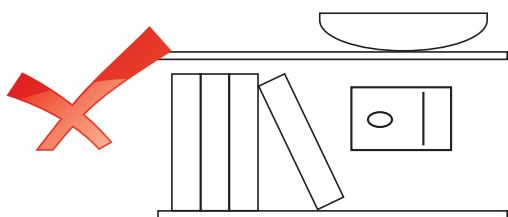

Fig. 13.e

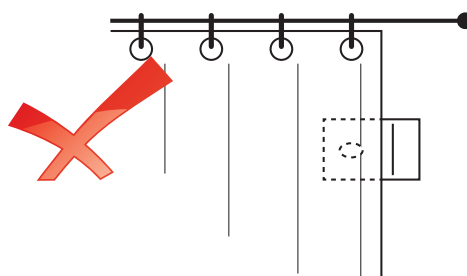

Fig. 13.f

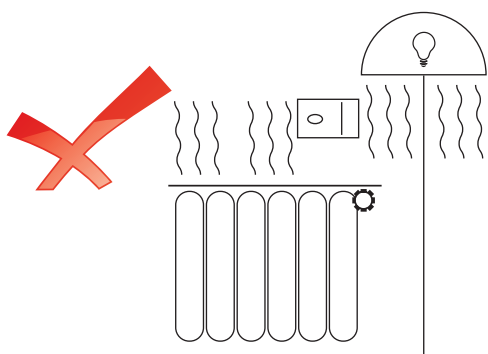

Fig. 13.g

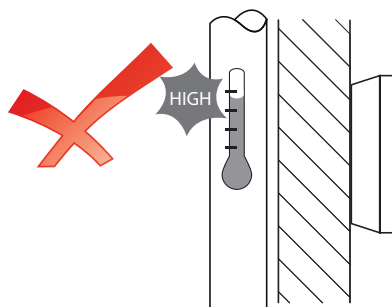

Fig. 13.h

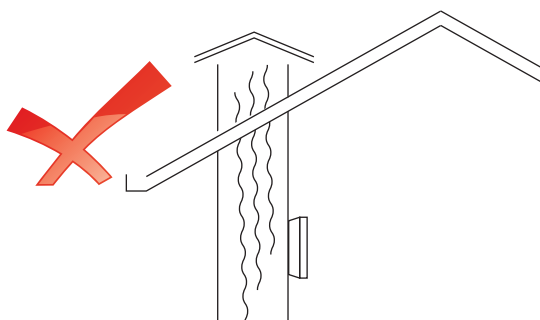

Fig. 13.i

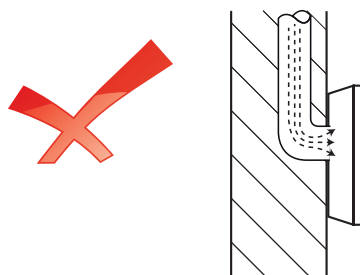

Fig. 13.l

13.2 Sensori temperatura e umidità condotta

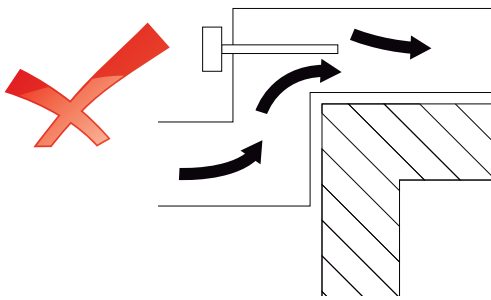

Fig. 13.m

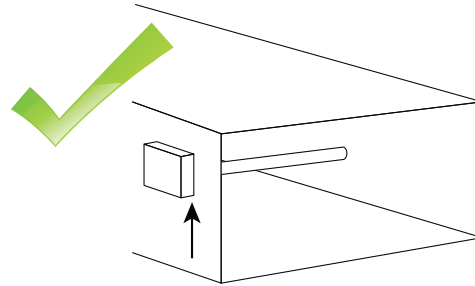

Fig. 13.n

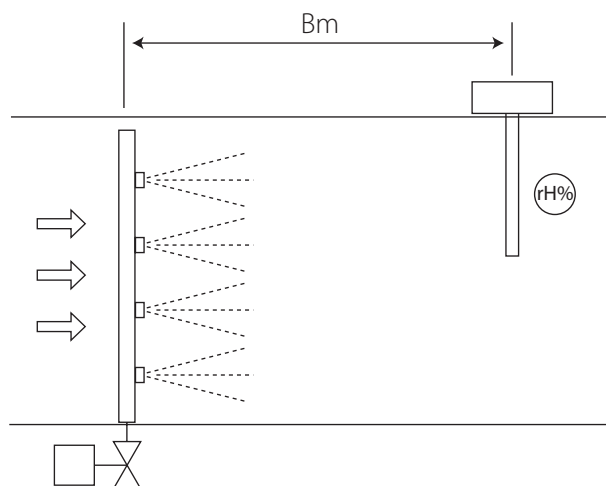
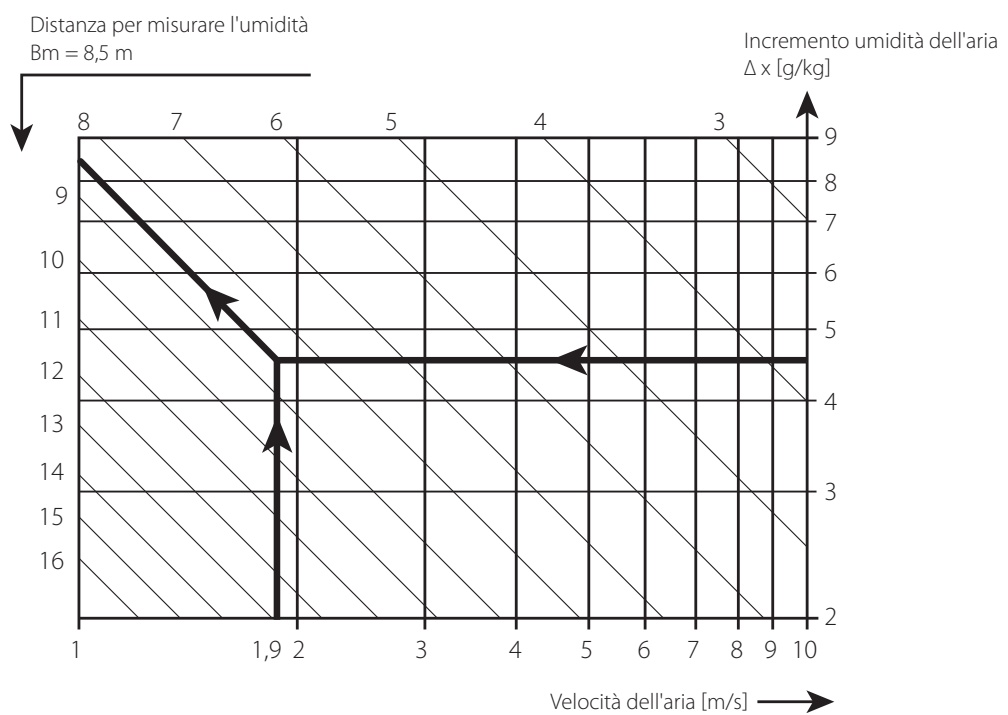

Fig. 13.o

13.3 Sensori di temperatura

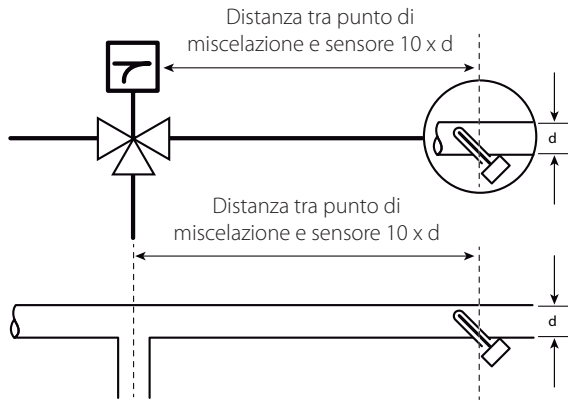

Fig. 13.p

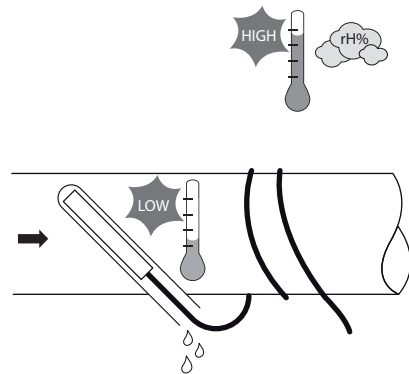

Fig. 13.q

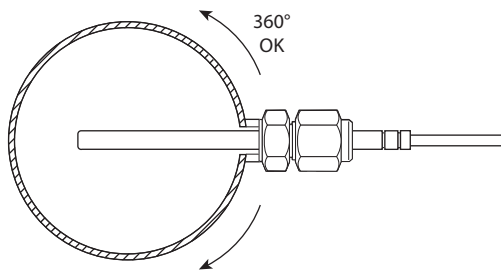

Fig. 13.r

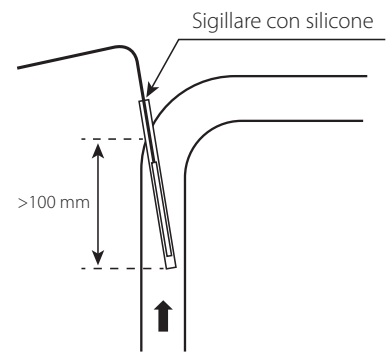

Fig. 13.s

13.4 Sensori di pressione

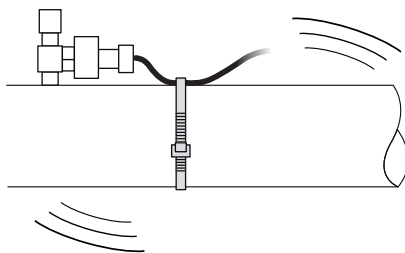

Fig. 13.t

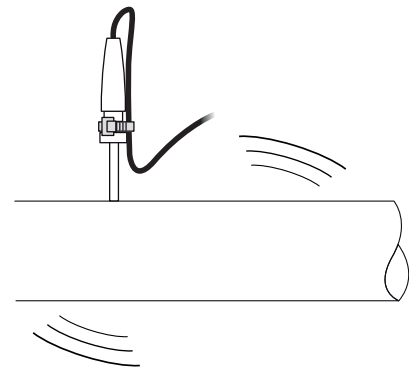

Fig. 13.u

13.5 Sensori fughe gas

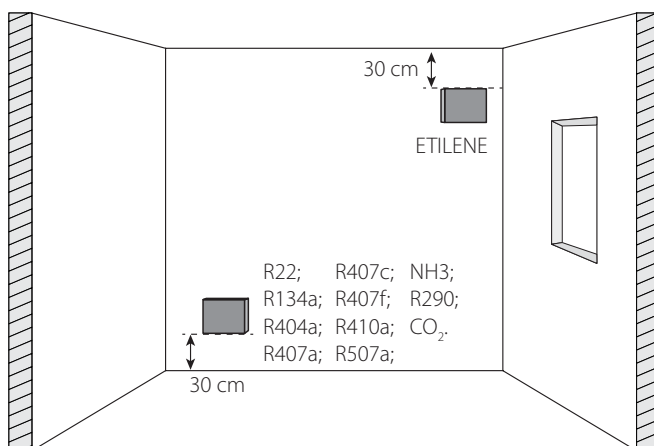

Fig. 13.v

WARNING



CAREL bases the development of its products on decades of experience in HVAC, on the continuous investments in technological innovations to products, procedures and strict quality processes with in-circuit and functional testing on 100% of its products, and on the most innovative production technology available on the market. CAREL and its subsidiaries nonetheless cannot guarantee that all the aspects of the product and the software included with the product respond to the requirements of the final application, despite the product being developed according to start-of-the-art techniques.

The customer (manufacturer, developer or installer of the final equipment) accepts all liability and risk relating to the configuration of the product in order to reach the expected results in relation to the specific final installation and/or equipment. CAREL may, based on specific agreements, act as a consultant for the positive commissioning of the final unit/application, however in no case does it accept liability for the correct operation of the final equipment/system.

The CAREL product is a state-of-the-art product, whose operation is specified in the technical documentation supplied with the product or can be downloaded, even prior to purchase, from the website www.CAREL.com.

Each CAREL product, in relation to its advanced level of technology, requires setup / configuration / programming / commissioning to be able to operate in the best possible way for the specific application. The failure to complete such operations, which are required/indicated in the user manual, may cause the final product to malfunction; CAREL accepts no liability in such cases.

Only qualified personnel may install or carry out technical service on the product. The customer must only use the product in the manner described in the documentation relating to the product.

In addition to observing any further warnings described in this manual, the following warnings must be heeded for all CAREL products:

- Prevent the electronic circuits from getting wet. Rain, humidity and all types of liquids or condensate contain corrosive minerals that may damage the electronic circuits. In any case, the product should be used or stored in environments that comply with the temperature and humidity limits specified in the manual.
- Do not install the device in particularly hot environments. Too high temperatures may reduce the life of electronic devices, damage them and deform or melt the plastic parts. In any case, the product should be used or stored in environments that comply with the temperature and humidity limits specified in the manual.
- Do not attempt to open the device in any way other than described in the manual.
- Do not drop, hit or shake the device, as the internal circuits and mechanisms may be irreparably damaged.
- Do not use corrosive chemicals, solvents or aggressive detergents to clean the device.
- Do not use the product for applications other than those specified in the technical manual.

All of the above suggestions likewise apply to the controllers, serial boards, programming keys or any other accessory in the CAREL product portfolio. CAREL adopts a policy of continual development. Consequently, CAREL reserves the right to make changes and improvements to any product described in this document without prior warning.

The technical specifications shown in the manual may be changed without prior warning.

The liability of CAREL in relation to its products is specified in the CAREL general contract conditions, available on the website www.CAREL.com and/or by specific agreements with customers; specifically, to the extent where allowed by applicable legislation, in no case will CAREL, its employees or subsidiaries be liable for any lost earnings or sales, losses of data and information, costs of replacement goods or services, damage to things or people, downtime or any direct, indirect, incidental, actual, punitive, exemplary, special or consequential damage of any kind whatsoever, whether contractual, extra-contractual or due to negligence, or any other liabilities deriving from the installation, use or impossibility to use the product, even if CAREL or its subsidiaries are warned of the possibility of such damage.

DISPOSAL



INFORMATION FOR USERS ON THE CORRECT HANDLING OF WASTE ELECTRICAL AND ELECTRONIC EQUIPMENT (WEEE)

In reference to European Union directive 2002/96/EC issued on 27 January 2003 and the related national legislation, please note that:

- WEEE cannot be disposed of as municipal waste and such waste must be collected and disposed of separately;
- the public or private waste collection systems defined by local legislation must be used. In addition, the equipment can be returned to the distributor at the end of its working life when buying new equipment;
- the equipment may contain hazardous substances: the improper use or incorrect disposal of such may have negative effects on human health and on the environment;
- the symbol (crossed-out wheeled bin) shown on the product or on the packaging and on the instruction sheet indicates that the equipment has been introduced onto the market after 13 August 2005 and that it must be disposed of separately;
- in the event of illegal disposal of electrical and electronic waste, the penalties are specified by local waste disposal legislation.

Warranty on the materials: 2 years (from the date of production, excluding consumables).

Approval: the quality and safety of CAREL INDUSTRIES Hqs products are guaranteed by the ISO 9001 certified design and production system.

WARNING: separate as much as possible the probe and digital input signal cables from the cables carrying inductive loads and power cables to avoid possible electromagnetic disturbance.
Never run power cables (including the electrical panel wiring) and signal cables in the same conduits.



READ CAREFULLY IN THE TEXT!

Contents

1. PASSIVE TEMPERATURE SENSORS	7
1.1 Selection guide based on the application	7
2. OBSERVATIONS ON HEAT TRANSMISSION IN TEMPERATURE MEASUREMENTS	8
3. ACTIVE TEMPERATURE AND HUMIDITY SENSORS	8
4. ACTIVE AIR QUALITY SENSORS	9
5. REFRIGERANT GAS LEAKAGE SENSORS (R22, R134A, R290, R404A, R407C-F, R410A, R744, ETHYLENE)	9
6. PRESSURE SENSORS	10
7. DIFFERENTIAL PRESSURE SENSORS	10
8. FLOOD SENSORS	11
9. FROST SENSORS	11
10. SMOKE-FIRE SENSORS	11
11. LEVEL SENSORS	11
12. INSTALLATION DIAGRAMS BY APPLICATION	12
12.1 AHU.....	12
12.2 HVAC: A/W - W/W chillers/heat pumps	14
12.3 CRAC.....	16
12.4 CRAC CW	18
12.5 HVAC: Technological/process cooling application Air/water chillers.....	20
12.6 HVAC: Commercial/residential applications - Rooftop.....	22
12.7 Blast chillers/freezers.....	24
12.8 Stand-alone showcases/bottle coolers.....	26
12.9 Water-cooled stand-alone showcases.....	28
12.10 Centralised/multiplexed cabinets.....	30
12.11 Cold rooms.....	32
12.12 Transcritical CO ₂ systems.....	34
12.13 Subcritical CO ₂ systems.....	35
13. FURTHER SUGGESTIONS	36
13.1 Room temperature and humidity sensors.....	36
13.2 Duct temperature and humidity sensors.....	37
13.3 Temperature sensors.....	38
13.4 Pressure sensors.....	38
13.5 Gas leakage sensors.....	38

1. PASSIVE TEMPERATURE SENSORS

Preamble: the purpose of this manual is to guide users in choosing and correctly installing probes, so as to reduce typical measurement errors resulting from:

- the influence of thermal contact resistance, the conductive material and the environment surrounding the probe;
- radiation;
- temperature stratification.

1.1 Selection guide based on the application

The choice of the best installation conditions for a probe or sensor depends on the measurement requirements (what needs to be measured, where are the sensors positioned? E.g. low temperature and high humidity – probable condensate and frost formation on the sensor;

high temperature – damage to the sheath or the fixing system):

1. Based on the fluid (gas or liquid), static or moving, which determines stratification of the fluid measured, heat exchange with the measurement system (sensor element, sheath, tubing, etc.); everything that increases thermal resistance and inertia and therefore causes various reading errors;
2. Based on the dynamics (if the phenomenon measured is very slow with small variations over time, or alternatively varies considerably in a short time);
4. Based on the operating range with positive – negative temperature variations, or alternatively positive or negative temperature variations only;
5. Based on the presence and type of contaminants (no UV -> no direct exposure to sunlight of the probe cable or plastic enclosures).

Note: the application diagrams shown below represent typical installations. Some applications may be a combination of several diagrams.

P/N	Type	Working range [°C]	IP	Casing-cap		Material		NOTES
				Ø [mm]	L [mm]	cap	cable	
NTC*HP*	NTC	-50T105	IP67	6x5	15	Polyolefin	Polyolefin	Single insulated cable
NTC*WH*	NTC	-50T105	IP68	6	50	AISI316	TPE	
NTC*WF*	NTC	-50T105	IP67	4	40	AISI316	TPE	
NTC*WP*	NTC	-50T105	IP67	6	100/200/300	AISI316	TPE	
NTC*HF*	NTC	-50T105	IP67	6x6	20	TPE	TPE	With cable tie, single insulated cable
NTC*WS*	NTC	-40T105	IP67	6x6	20	TPE + Cu	TPE	With cable tie, double insulated cable
NTC*HT*	NTC	-30T150	IP67	5	20/50	PE/AISI316	PE	Two versions (PE and AISI)
NTC*LT*	NTC	-80T105	IP67	6x6	150	AISI316		
NTC*PS*	NTC	-50T105	IP67	98x20	105	Santoprene	TPE	Product temperature simulation
TSN*	NTC	-40T120	IP68	3	13	AISI316	-	Direct immersion M 1/8 Gas - PN40
TSC*	NTC	-40T90	IP68	4	15	Nickel-plated brass	TPE	Direct immersion M14 - PN40
NTC*INF*	NTC	-50T90	IP67	5/4	150/169/100	AISI304/316	Silicone	Suitable for use with food to measure product core temperature
NTC*WG*	NTC	-50T105	IP67	6x6	40	Aluminium	TPE	Used on showcases together with humidity probe to activate anti-sweat
PT100*	PT100	-50T250 0T400	IP65	6	100	AISI316	Silicone rubber	
PT1*HP*	PT1000	-50T105	IP67	6x5	15	Polyolefin	Polyolefin	Single insulated cable
PT1*WF*	PT1000	-50T105	IP67	4	40	AISI316	TPE	
PT1*WP*	PT1000	-50T105	IP67	6	50	AISI316	TPE	
PT1*HT*	PT1000	-50T250	IP67	6	40	AISI304	Silicon resin	
PT1*HF*	PT1000	-50T105	IP67	6x6	20	TPE	TPE	With cable tie, single insulated cable
PT1*PS*	PT1000	-50T105	IP67	98x20	105	Santoprene	TPE	Special applications
TST*	PT1000	-40T120	IP68	3	13	AISI316	-	Direct immersion M 1/8 Gas - PN40
TSM*	PT1000	-40T90	IP68	4	15	Nickel-plated brass	TPE	Direct immersion M14 - PN25
TSQ*	PT1000	-50T350	IP65	3	150	AISI316		
PT1*INF*	PT1000	-50T200	IP67	5/4	100	AISI316	TPE	Suitable for use with food to measure product core temperature
PTC*	PTC	-30T105	IP67	6	40		PVC	

Tab. 1.a

Note: for further technical details, see the passive sensor manual +030220655 (IT-EN).



2. OBSERVATIONS ON HEAT TRANSMISSION IN TEMPERATURE MEASUREMENTS

Preamble: whatever method is used to measure temperature, the measured temperature is never the actual temperature of the fluid being measured.

The deviation from the real value (which represents the measurement error) is a result of heat transmission, a process that affects any object or fluid with a difference in temperature from another nearby fluid or object, or alternatively a dynamic variation in temperature (difference from previous values).

The following factors cause the measurement to deviate from the real value:

1. Temperature difference in the area surrounding the point of measurement;
2. Thermal mass of the temperature measuring system (e.g. pipe, socket, probe), which increases the total measurement time constant.

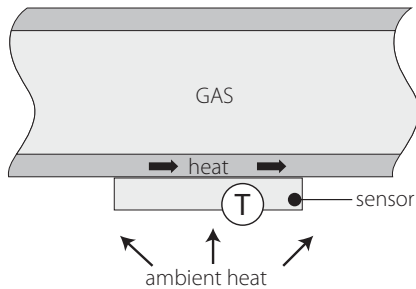

Commonly, when measuring the temperature of a fluid, the influence of the temperature difference in the area surrounding the point of measurement is often underestimated. When the difference between the point of measurement and the surrounding environment is significant (in the tens of degrees), the error is no longer negligible.

When needing to control a temperature that is subject to variations, precision of control will also depend on the measurement time constant:

the lower the time constant, the quicker control will respond to a changing temperature, and consequently the lower the instant error will be between the value read and the real value.

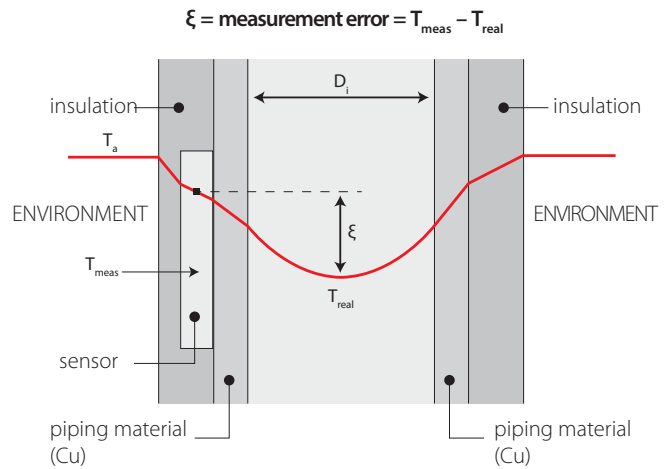

Note: the measurement error generated by the influence of ambient temperature is particularly important with smaller diameter piping: the ratio between masses (pipe and fluid) is in fact inversely proportional to pipe diameter.

$$\frac{A_e}{V_i} = \frac{D_e \cdot \pi}{D_i^2 \cdot \pi/4} \cong \frac{4}{D}$$

A_e = outside surface area
 V_i = inside volume

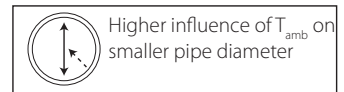

3. ACTIVE TEMPERATURE AND HUMIDITY SENSORS

	Type of output							
	Temperature	Humidity	Carel NTC	Carel NTC & -0.5-1 V / 4-20 mA	-0.5-1 V 4-20 mA	Carel NTC & 0-10 V	0-10 V	RS485 serial
Duct	-10 T60°C	-	DPDT011000	-	DPDT010000	-	-	DPDT014000
	-10 T60°C	10-90%	-	DPDC111000	DPDC110000	-	DPDC112000	DPDC114000
	-20-70°C	0-100%	-	-	DPDC210000	-	DPDC212000	DPDC214000
Industrial environment	-10 T60°C	-	DPPT011000	-	DPPT010000	-	-	DPPT014000
	-10 T60°C	10-90%	-	DPDC111000	DPDC110000	-	DPDC112000	DPDC114000
	-20-70°C	0-100%	-	-	DPDC210000	-	DPDC212000	DPDC214000
Wall-mounting	-10 T60°C	-	DPWT011000	-	DPWT010000	-	-	DPWT014000
	-10 T60°C	10-90%	-	DPWC111000	DPWC110000	DPWC115000	DPWC112000	DPWC114000
Remote sensor	-	30-90°C	-	-	ASIT030000	-	-	-
	-	30-90°C Cable L= 2m	-	-	ASET030000	-	-	-
	-	30-90°C Cable L= 3m	-	-	ASET030001	-	-	-
-	30-90°C Cable L= 4m	-	-	ASET030002	-	-	-	

Tab. 3.a

Note: for further technical details, see the active sensor manual +030220660 (IT-EN)



4. ACTIVE AIR QUALITY SENSORS

Carel DP*Q* P/Ns		
Version	Outputs	Carel part number
VOC air quality sensor, wall-mounting	0 to 10V – 4 to 20 mA	DPWQ306000
CO2 air quality sensor, wall-mounting	0 to 10V	DPWQ402000
VOC + CO2 air quality sensor, wall-mounting	0 to 10V	DPWQ502000
VOC air quality sensor, duct version	0 to 10V – 4 to 20 mA	DPDQ306000
CO2 air quality sensor, duct version	0 to 10V	DPDQ402000
VOC + CO2 air quality sensor, duct version	0 to 10V	DPDQ502000

Tab. 4.a

Note: for further technical details see the air quality sensor technical leaflets:

VOC	VOC + CO ₂
+050001290 - IT	+050001300 - IT
+050001291 - GB	+050001301 - GB
+050001292 - FR	+050001302 - FR
+050001293 - DE	+050001303 - DE
+050001294 - RU	+050001304 - RU



5. REFRIGERANT GAS LEAKAGE SENSORS (R22, R134A, R290, R404A, R407C-F, R410A, R744, ETHYLENE)

Semiconductor (IP41)	Semiconductor with 5 m remote sensor (IP66)	Description
DPWLA07000	DPWLA27000	R22 gas leak detector
DPWLB07000	DPWLB27000	R134a gas leak detector
DPWLC07000	DPWLC27000	R404a gas leak detector
DPWLR07000		R407a gas leak detector
DPWLD07000	DPWLD27000	R407c gas leak detector
DPWLS07000		R407f gas leak detector
DPWLE07000	DPWLE27000	R410a gas leak detector
DPWLT07000	DPWLT27000	R507a gas leak detector
DPWLG07000		NH3 gas leak detector
DPWLQ07000		ETHYLENE gas leak detector
DPWLP07000		R290 gas leak detector

Infrared (IP66)	Infrared with 5 m remote sensor (IP66)	Description
DPWL417000	DPWL427000	Sensor rilevam. gas CO ₂

Tab. 5.a

Note: for further technical details, see the specific manual: +0300035EN or +0300035IT



6. PRESSURE SENSORS

Choice of pressure sensor according to operating pressure.

Gas	Low temperature evaporator	Medium and high temperature evaporator	Condenser
R134a	SPKT0053R*/P* (0-5 V; -1.0-4.2 barg) SPKT0021C*/D* (4-20 mA; -0.5-7.0 barg) SPKS0019R1 (0-5 V; 0-9 barg) weld version	SPKT0013R*/P* (0-5 V; -1-9.3 barg) SPKT0011C*/D* (4-20 mA; 0-10 barg) SPKS0019R1 (0-5 V; 0-9 barg) weld version	SPKT0033R*/P* (0-5 V; 0-34.5 barg) SPKT0031C*/D* (4-20 mA; 0-30 barg) SPKS0039R1 (0-5 V; 0-34 barg) weld version
R290	SPKT0013R*/P* (0-5 V; -1-9.3 barg) SPKT0011C*/D* (4-20 mA; 0-10 barg) SPKS0019R1 (0-5 V; 0-9 barg) weld version	SPKT0013R*/P* (0-5 V; -1-9.3 barg) SPKT0011C*/D* (4-20 mA; 0-10 barg) SPKS0019R1 (0-5 V; 0-9 barg) weld version	SPKT0033R*/P* (0-5 V; 0-34.5 barg) SPKT0031C*/D* (4-20 mA; 0-30 barg) SPKS0039R1 (0-5 V; 0-34 barg) weld version
R404a	SPKT0013R*/P* (0-5 V; -1-9.3 barg) SPKT0011C*/D* (4-20 mA; 0-10 barg) SPKS0019R1 (0-5 V; 0-9 barg) weld version	SPKT0013R*/P* (0-5 V; -1-9.3 barg) SPKT0011C*/D* (4-20 mA; 0-10 barg) SPKS0019R1 (0-5 V; 0-9 barg) weld version	SPKT0033R*/P* (0-5 V; 0-34.5 barg) SPKT0031C*/D* (4-20 mA; 0-30 barg) SPKS0039R1 (0-5 V; 0-34 barg) weld version
R407A	SPKT0013R*/P* (0-5 V; -1-9.3 barg) SPKT0011C*/D* (4-20 mA; 0-10 barg) SPKS0019R1 (0-5 V; 0-9 barg) weld version	SPKT0013R*/P* (0-5 V; -1-9.3 barg) ⁽¹⁾ SPKT0011C*/D* (4-20 mA; 0-10 barg) ⁽¹⁾ SPKS0019R1 (0-5 V; 0-9 barg) weld version	SPKT0033R*/P* (0-5 V; 0-34.5 barg) SPKT0031C*/D* (4-20 mA; 0-30 barg) SPKS0039R1 (0-5 V; 0-34 barg) weld version
R407C	SPKT0013R*/P* (0-5 V; -1-9.3 barg) SPKT0011C*/D* (4-20 mA; 0-10 barg) SPKS0019R1 (0-5 V; 0-9 barg) weld version	SPKT0013R*/P* (0-5 V; -1-9.3 barg) ⁽¹⁾ SPKT0011C*/D* (4-20 mA; 0-10 barg) ⁽¹⁾ SPKS0019R1 (0-5 V; 0-9 barg) weld version	SPKT0033R*/P* (0-5 V; 0-34.5 barg) SPKT0031C*/D* (4-20 mA; 0-30 barg) SPKS0039R1 (0-5 V; 0-34 barg) weld version
R407F	SPKT0013R*/P* (0-5 V; -1-9.3 barg) SPKT0011C*/D* (4-20 mA; 0-10 barg) SPKS0019R1 (0-5 V; 0-9 barg) weld version	SPKT0013R*/P* (0-5 V; -1-9.3 barg) ⁽¹⁾ SPKT0011C*/D* (4-20 mA; 0-10 barg) ⁽¹⁾ SPKS0019R1 (0-5 V; 0-9 barg) weld version	SPKT0033R*/P* (0-5 V; 0-34.5 barg) SPKT0031C*/D* (4-20 mA; 0-30 barg) SPKS0039R1 (0-5 V; 0-34 barg) weld version
R410A	SPKT0043R*/P* (0-5 V; 0-17.3 barg) SPKT0041C*/D* (4-20 mA; 0-18.2 barg) SPKS00F9R1 (0-5 V; 0-19 barg) weld version	SPKT0043R*/P* (0-5 V; 0-17.3 barg) SPKT0041C*/D* (4-20 mA; 0-18.2 barg) SPKS00F9R1 (0-5 V; 0-19 barg) weld version	SPKT00B6R*/P* (0-5 V; 0-45 barg) SPKT00B1C*/D* (4-20 mA; 0-44.8 barg) SPKS00B9R1 (0-5 V; 0-45 barg) weld version
R717	SPKT0021C*/D* (4-20 mA; -0.5-.7 barg)	SPKT0011C*/D* (4-20 mA; 0-10 barg)	SPKT0031C*/D* (4-20 mA; 0-30 barg)
R744	SPKT00G1C*/D* (4-20 mA; 0-60 barg)	SPKT00G1C*/D* (4-20 mA; 0-60 barg)	SPKT00H8C* (4-20 mA; 0-120 barg) SPKT00D8C* (4-20 mA; 0-150 barg)

Tab. 6.a

(1): for HVAC applications, use respectively

- SPKT0043R*/P* (0-5 V 0-17.3 barg)
- SPKT0041C*/D* (4-20 mA 0-18.2 barg)
- SPKS00F9R1 (0-5 V 0-19 barg) weld version

Specific documents: for further technical details see the pressure transducer technical leaflets:

- cable and connector +050000484
- 4-20 mA C series +050000486 (IT-EN) alternative: 4-20 mA D series +050000595 (IT-EN)
- 4-20 mA C series high pressure +050000596 (IT-EN)
- 0-5 V R series +050000485 (IT-EN) alternative: 0-5 V P series +050000598 (IT-EN)
- 0-5 V S series +050000488 (IT-EN)
- 0-5 V SPKS* series weld version +050000489 (IT-EN)

Note: the SPKS*R* series weld-version sensors comply with F-GAS regulation 842/2006, which requires devices installed in the system to be hermetically sealed and solidly secured by welding.



7. DIFFERENTIAL PRESSURE SENSORS

See the specific technical leaflets:

4-20 mA active sensors +050000651 (IT-EN)

P/N	Working range (adjustable)	Output
SPKD00U5N0	0 - 1000 Pa	4 - 20 mA
	0 - 2500 Pa	
	0 - 3000 Pa	
	0 - 5000 Pa	
SPKD00C5N0	- 50 - + 50 Pa	4 - 20 mA
	- 100 - + 100 Pa	
	0 - + 50 Pa	
	0 - + 100 Pa	

Tab. 7.a

On-off sensors +050000645 (IT-EN)

P/N	Description	Range (mbar)	
DCPD000100	Differential pressure switch	0.5 - 5.0	
DCPD010100	Differential pressure switch	0.5 - 5.0	with connection kit
DCPD001100	Differential pressure switch	0.2 - 2.0	
DCPD011100	Differential pressure switch	0.2 - 2.0	with connection kit

Tab. 7.b



8. FLOOD SENSORS

Technical leaflet +050004116

P/N	Description
FLOE000010	Flood detector
FLOS000000	Spot probe
FLOR000000	Strip sensor 25 m

Tab. 8.a



9. FROST SENSORS

Technical leaflet +050000646

P/N	Description	Range (°C)
DCTF000320	Single-stage frost thermostat	-10 to 15

Tab. 9.a



10. SMOKE-FIRE SENSORS

Technical leaflet +050000520

Smoke

P/N	Power supply voltage
SFFS000000	12-24 Vdc

Tab. 10.a

Fire

P/N	Power supply voltage
SFFF000000	12-24 Vdc

Tab. 10.b



11. LEVEL SENSORS

Technical leaflet +0500075ML

P/N	Description
LSR0013000	Level sensor – 2" Gas mechanical connector
LSR0023000	Level sensor – flanged mechanical connector

Tab. 11.a



12. INSTALLATION DIAGRAMS BY APPLICATION

12.1 AHU

KEY

T	Temperature
rH\%	Relative humidity
ΔP	Differential pressure
CO_2	CO_2
Voc	Volatile organic compounds

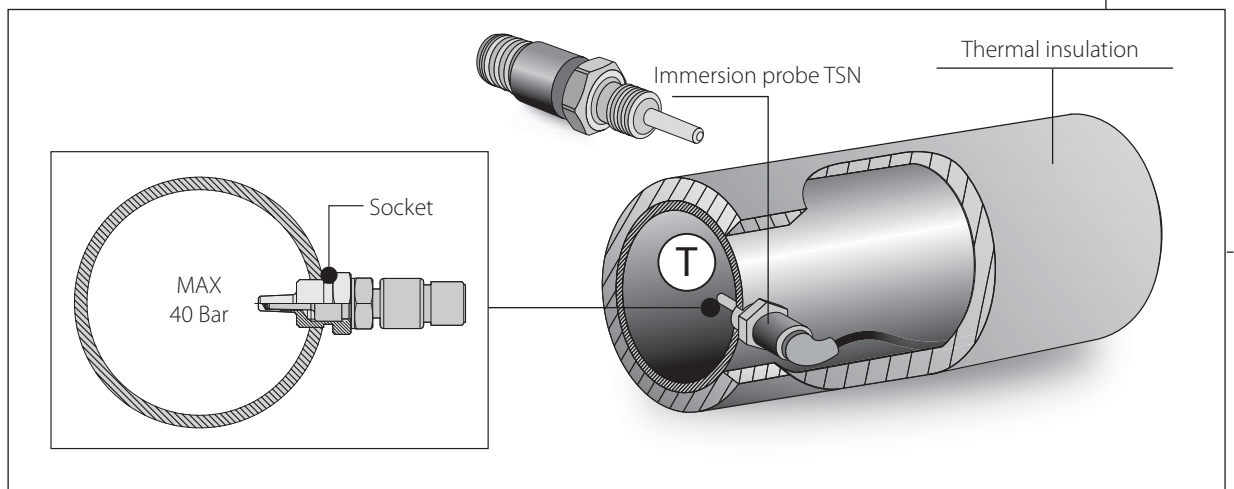
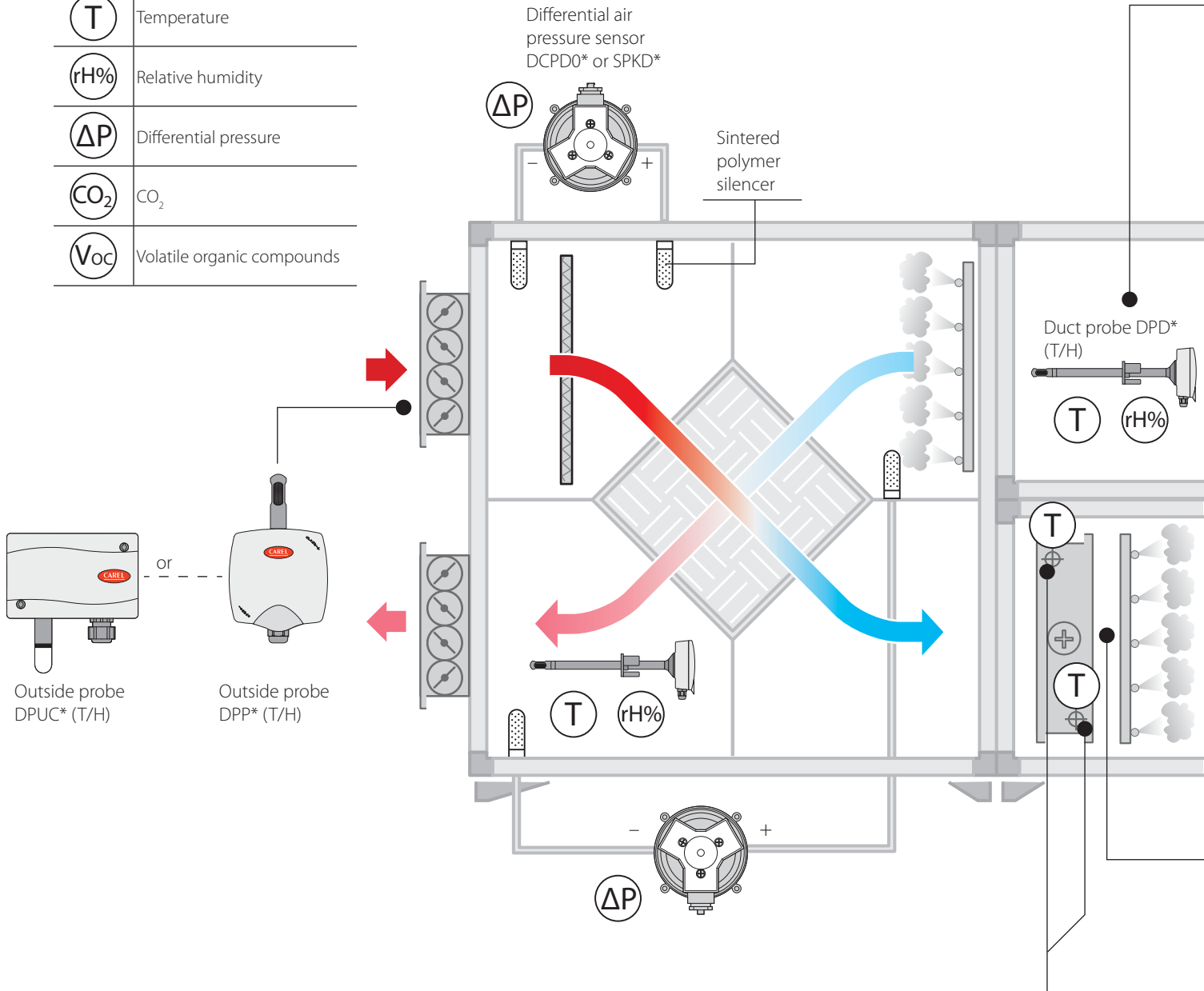

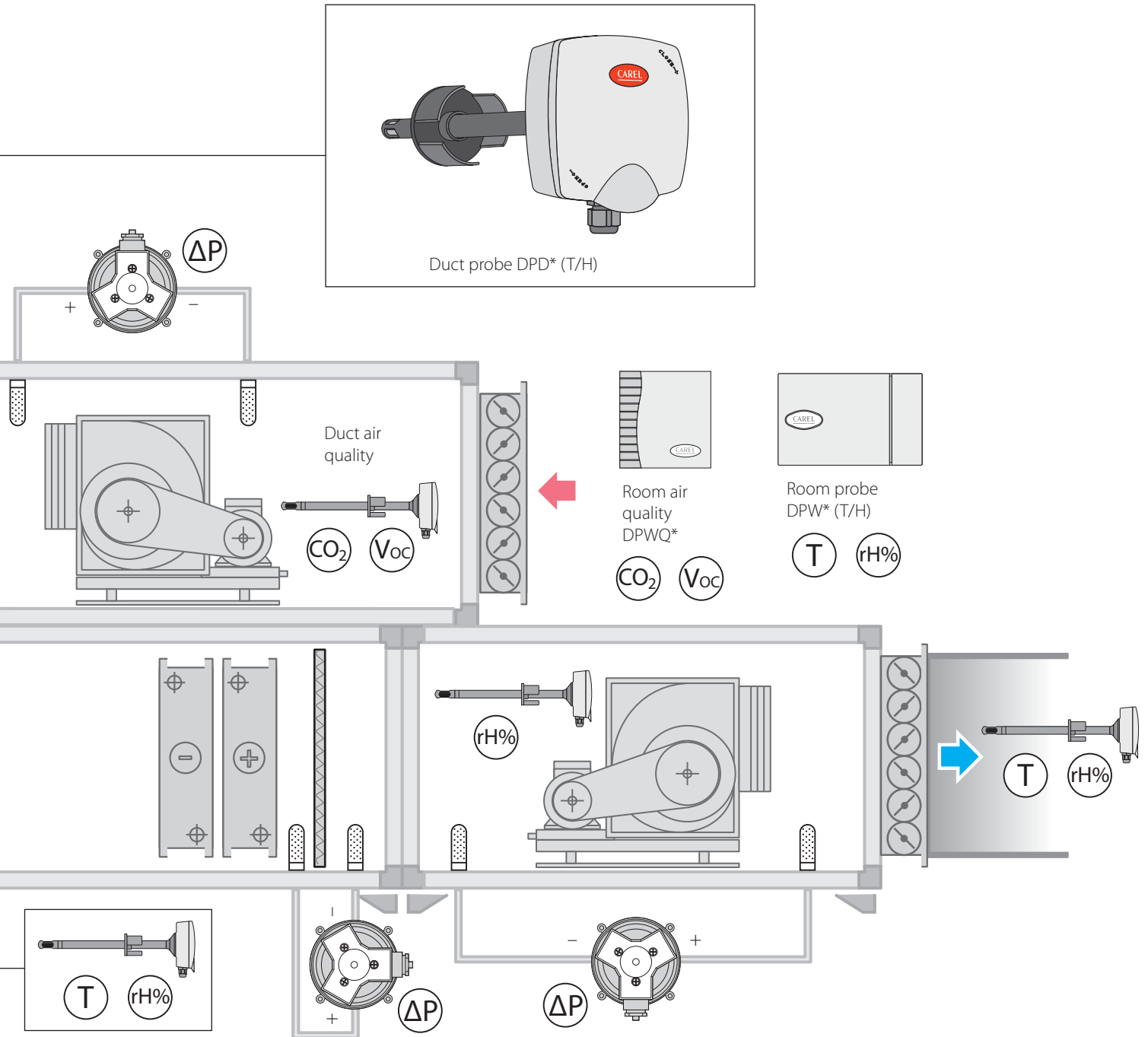

Alternative solutions

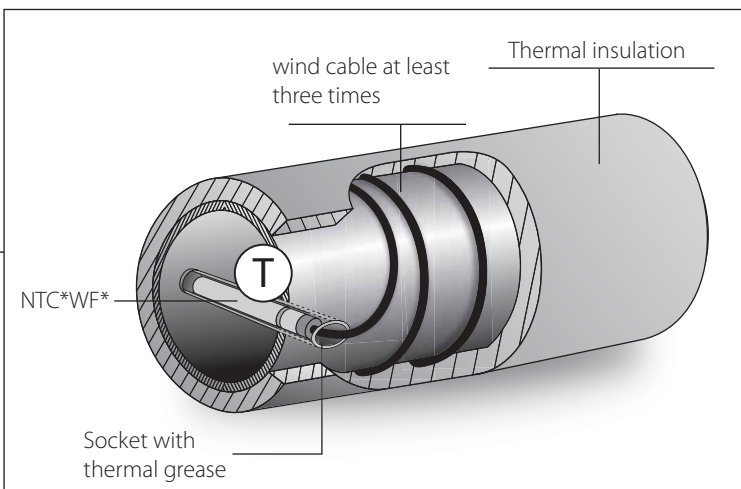

12.2 HVAC: /W - W/W chillers/heat pumps

KEY

T	Temperature
P	Pressure

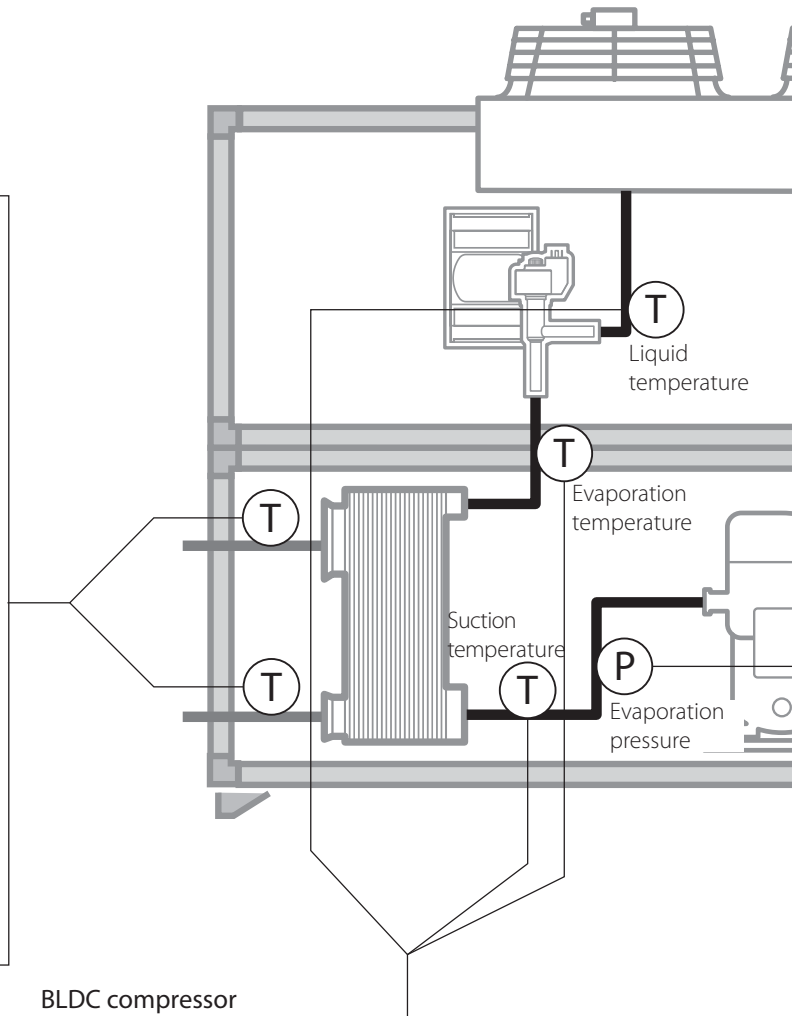
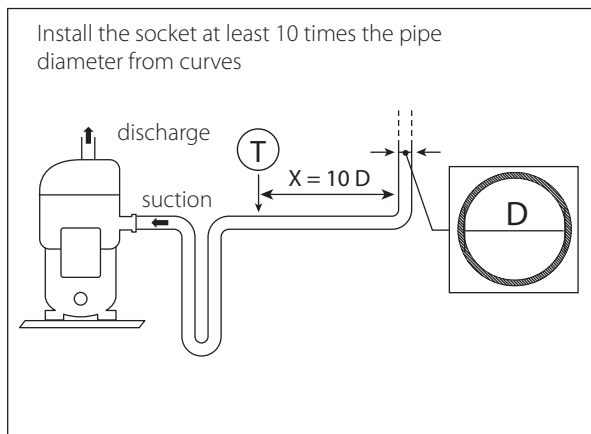
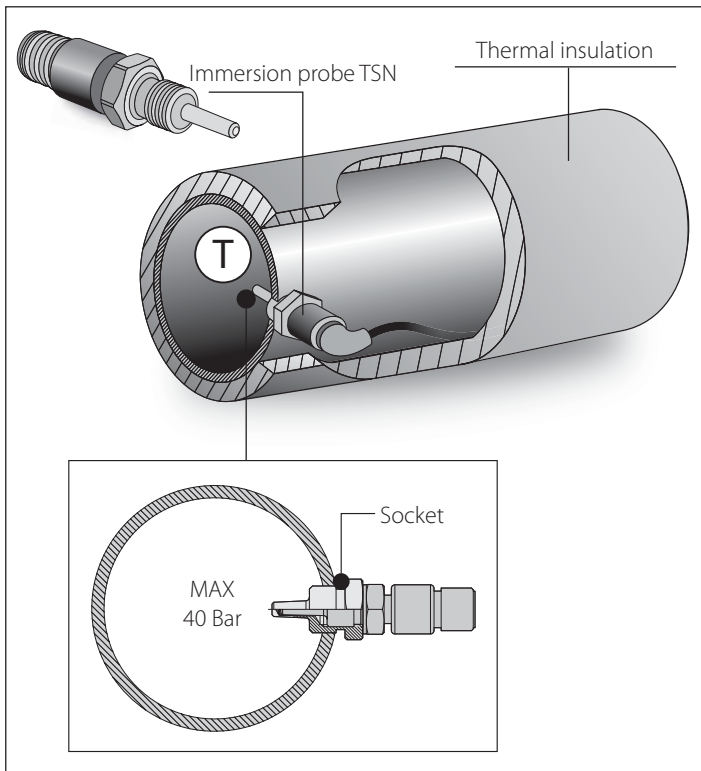

BLDC compressor

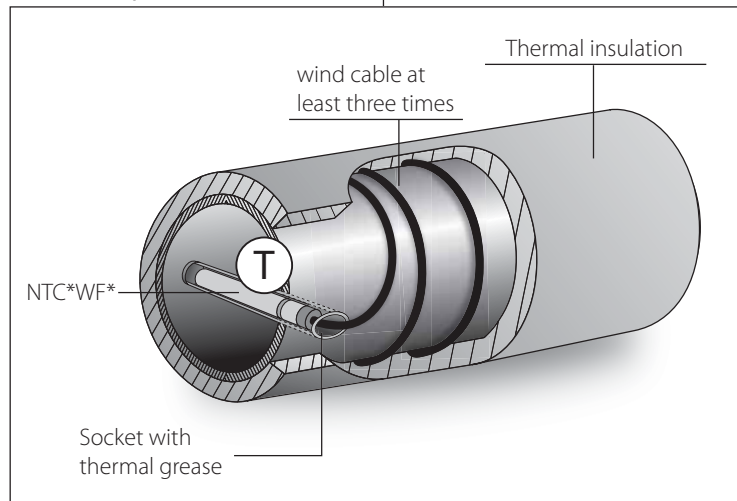

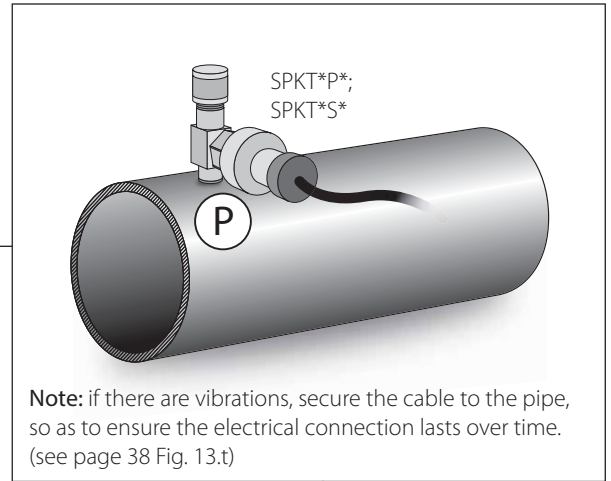
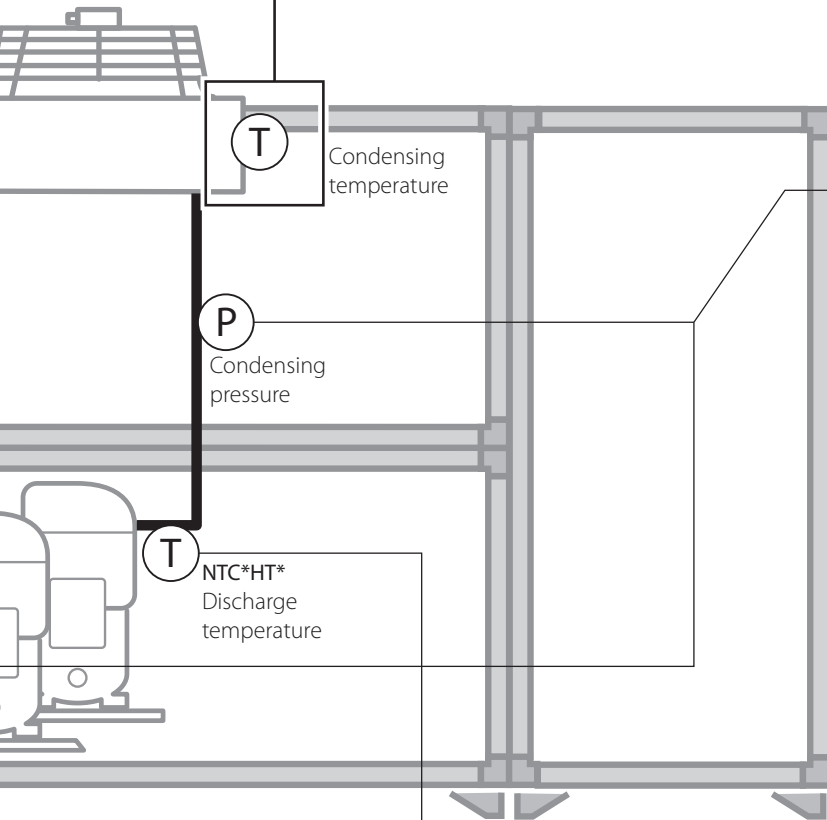
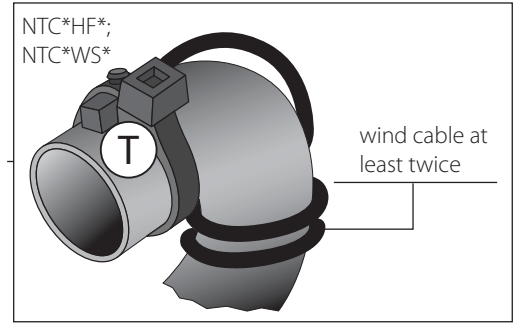
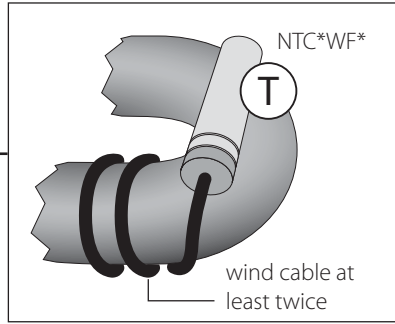
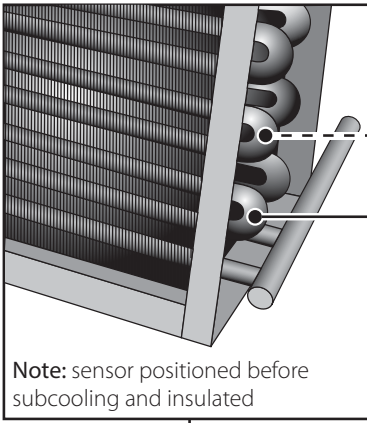

Connection with capillary

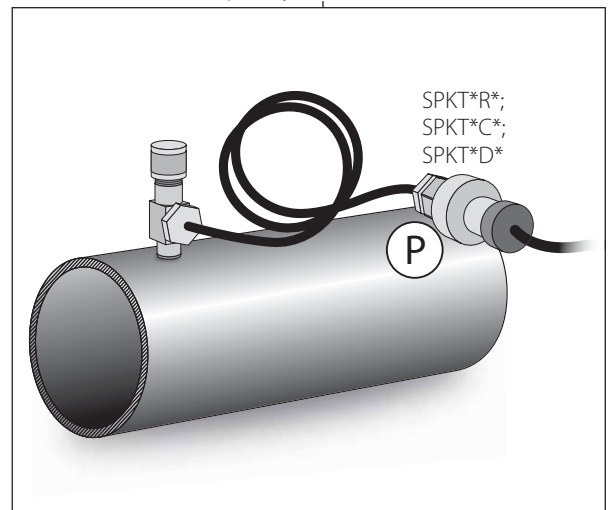

ON/OFF compressor

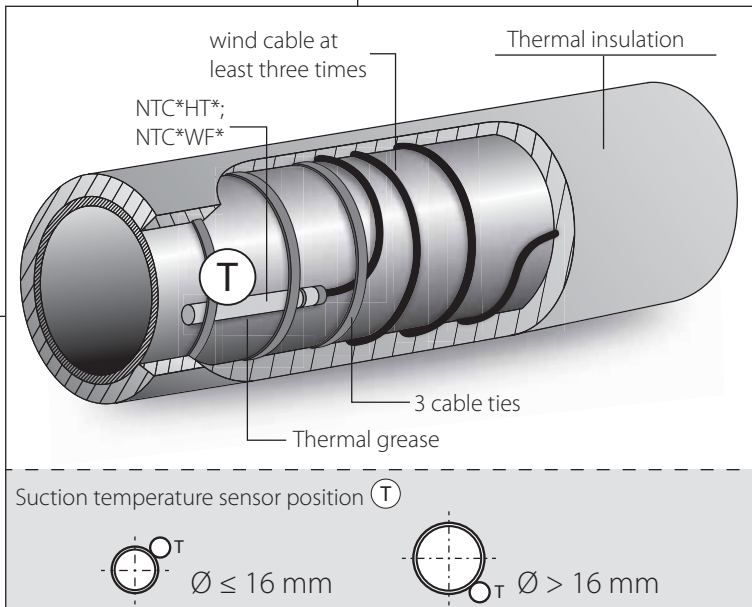

Welded connection

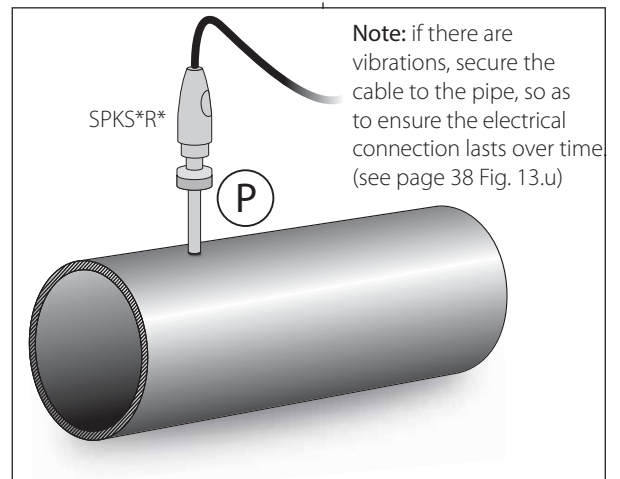

12.3 CRAC

KEY

T	Temperature
P	Pressure
rH%	Relative humidity
ΔP	Differential pressure
S	Smoke
F	Fire
L	Flood sensor

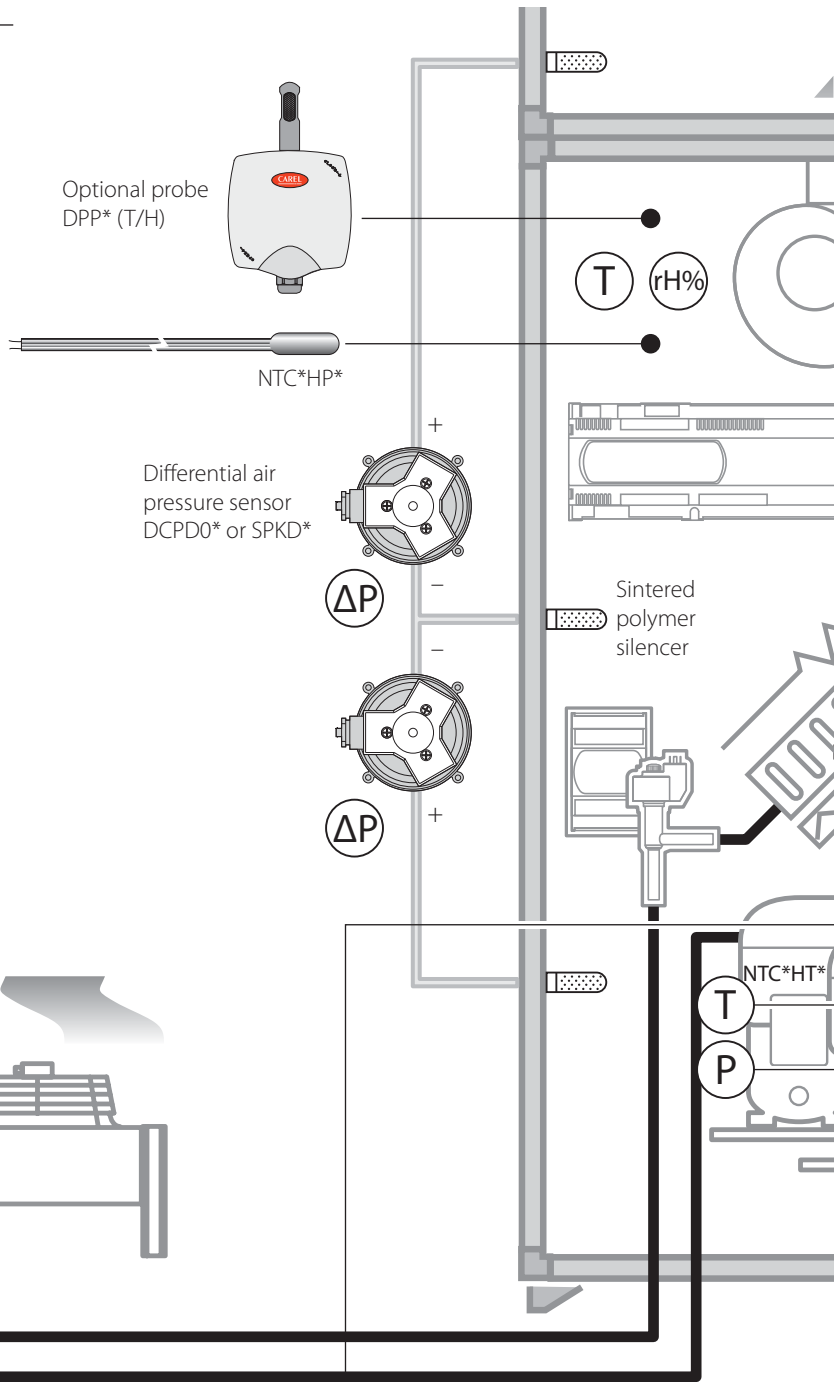
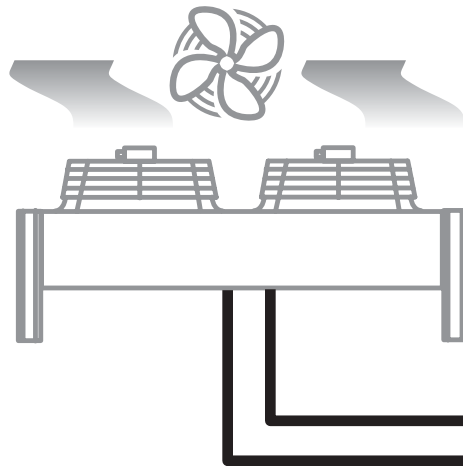

BLDC compressor

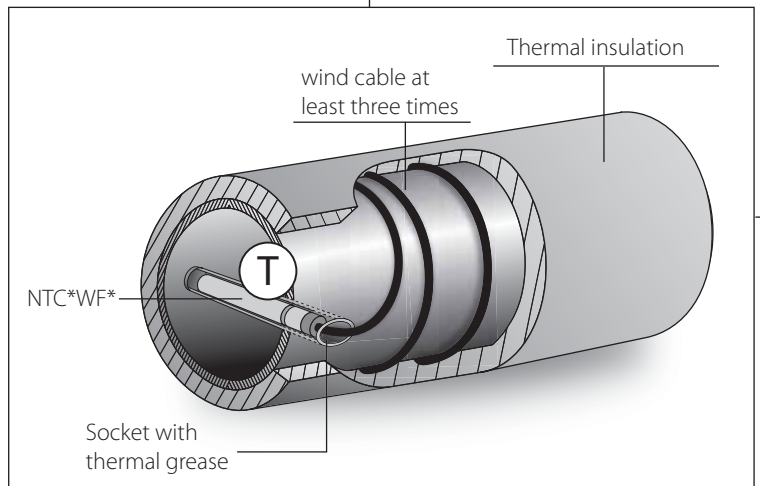
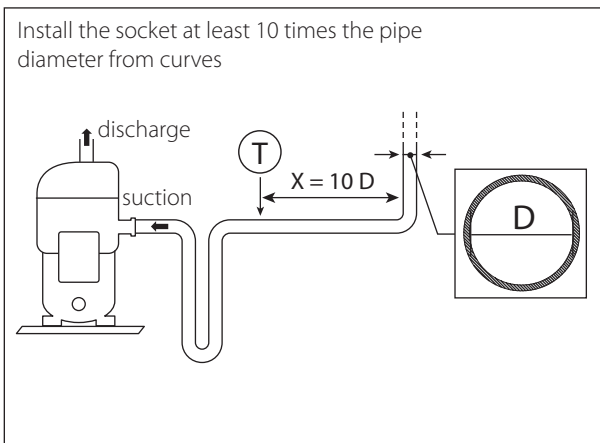

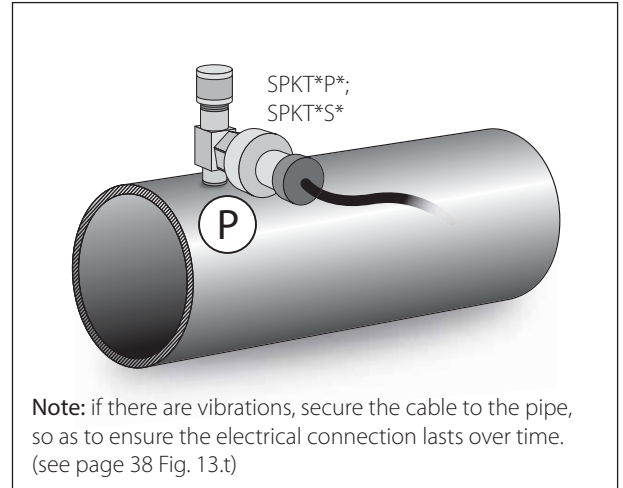
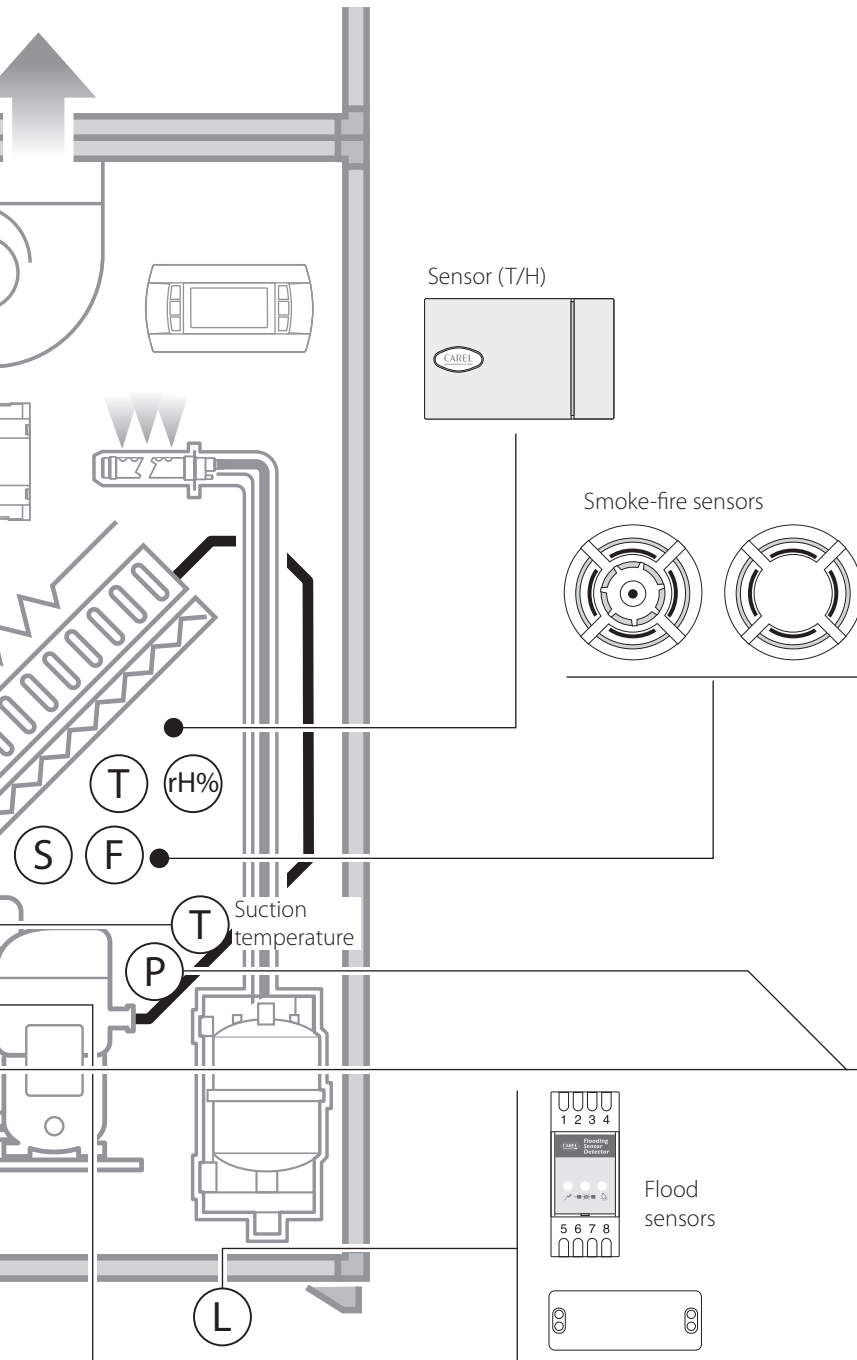

Connection with capillary

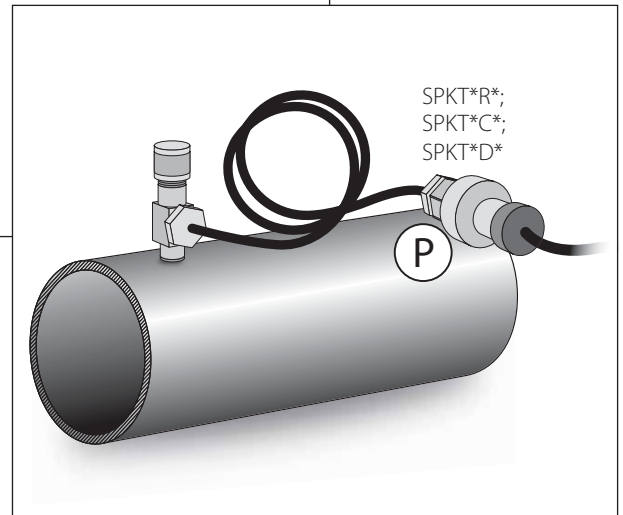

Welded connection

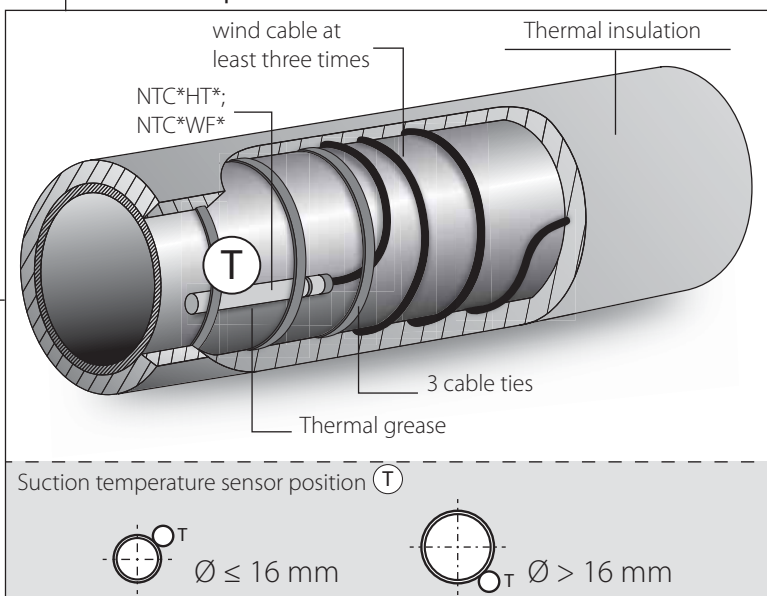
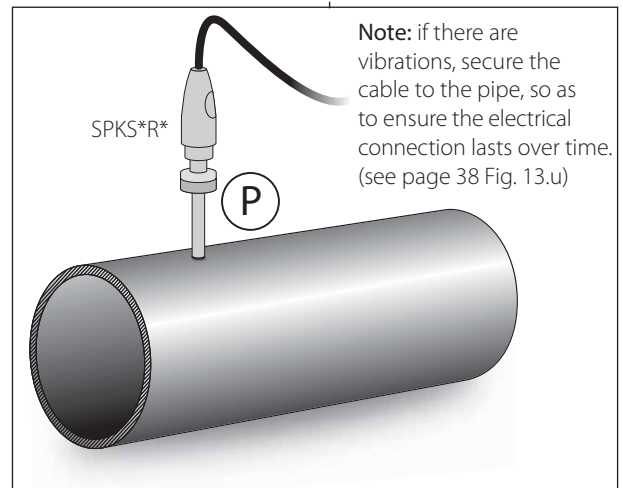

12.4 CRAC CW

KEY

T	Temperature
rH%	Relative humidity
ΔP	Differential pressure
S	Smoke
F	Fire
L	Flood sensor

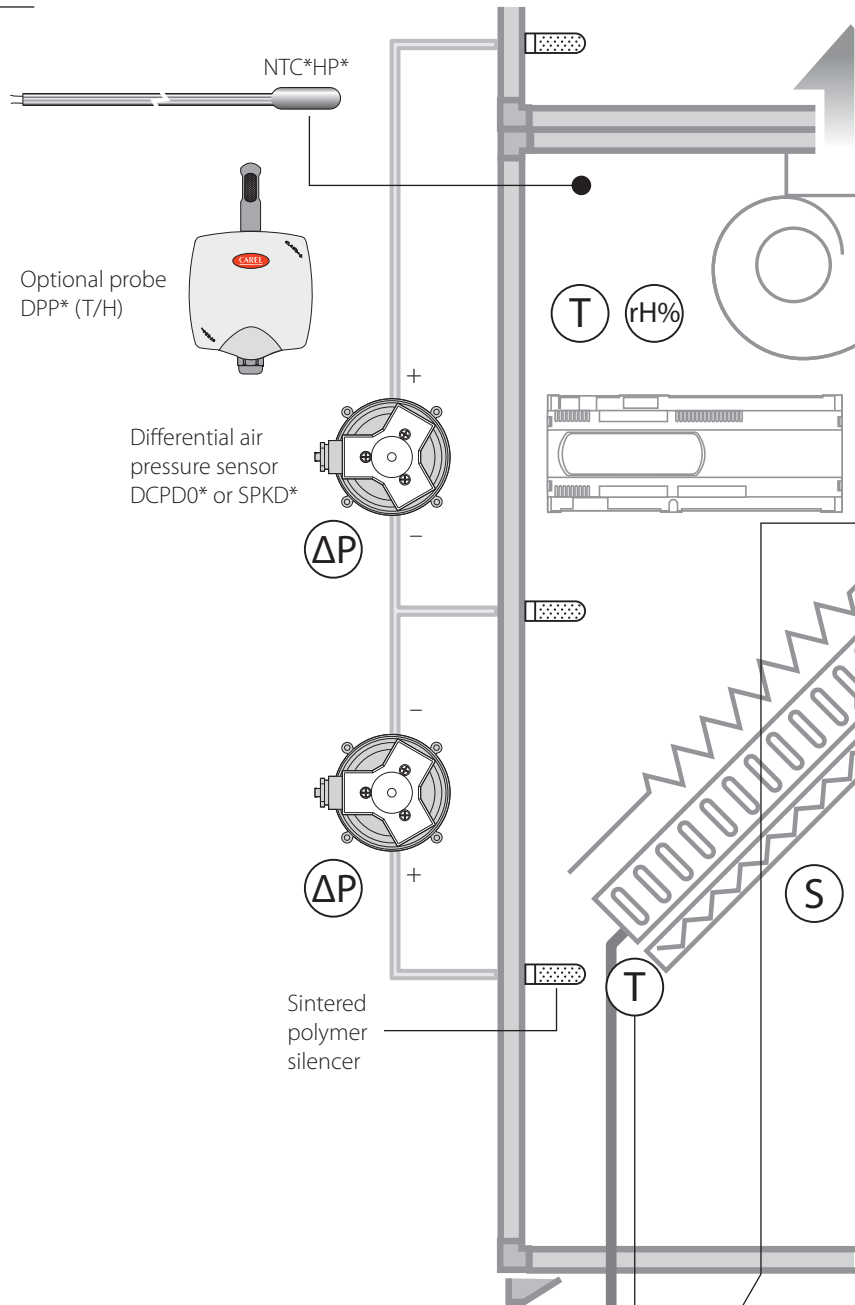

Control probe

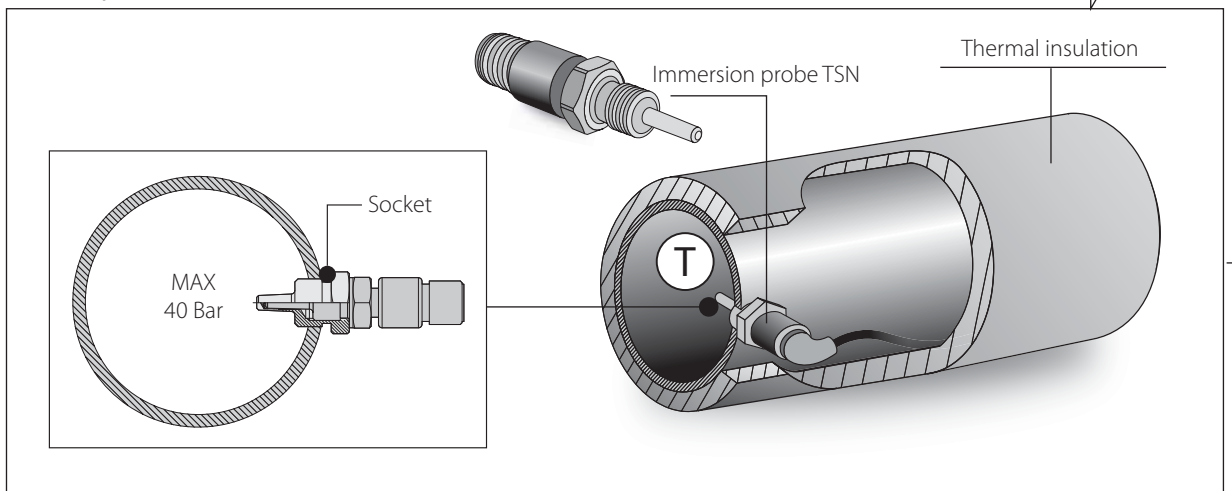

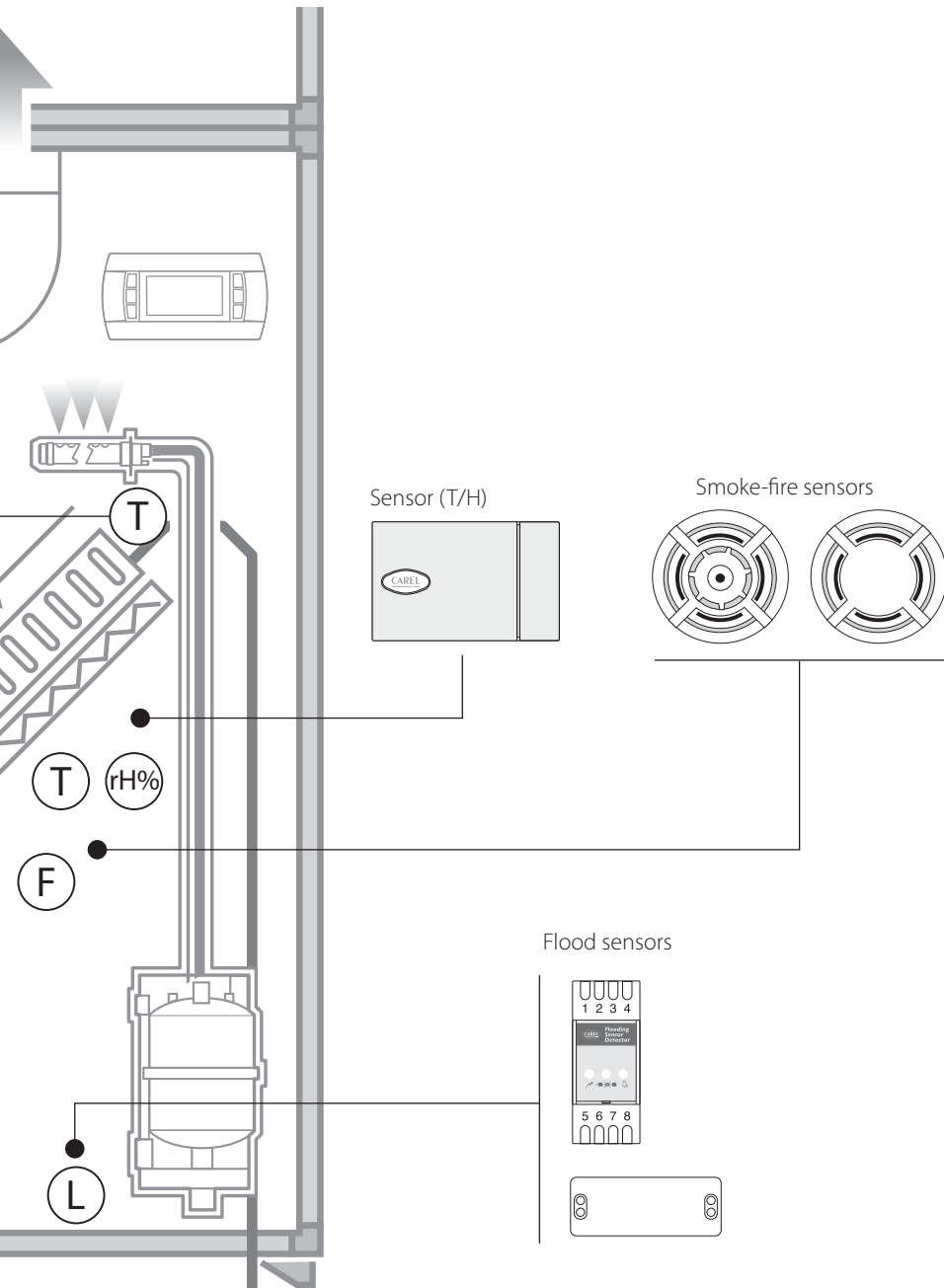

1st alternative solution - Reading probe

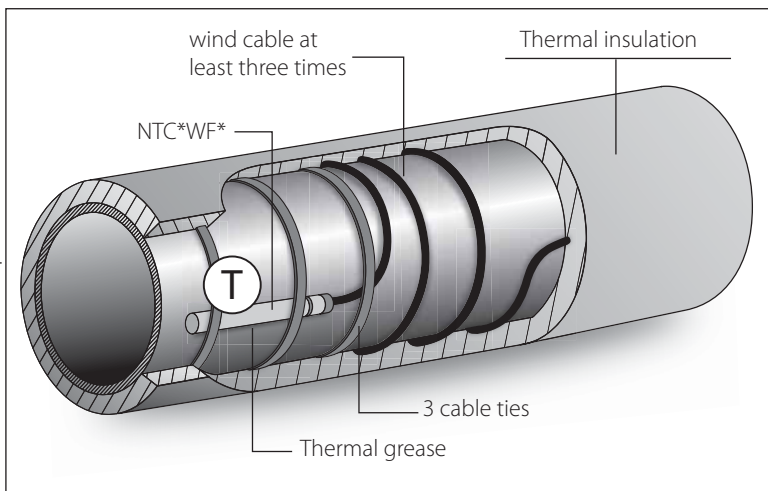

2nd alternative solution - Reading probe

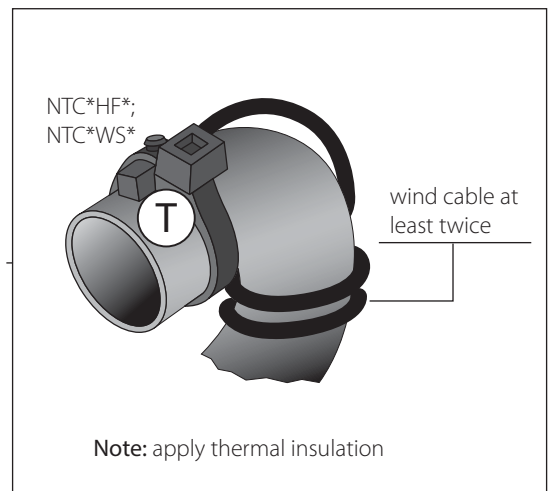

12.5 HVAC: Technological/process cooling application - Air/water chillers

KEY

T	Temperature
P	Pressure

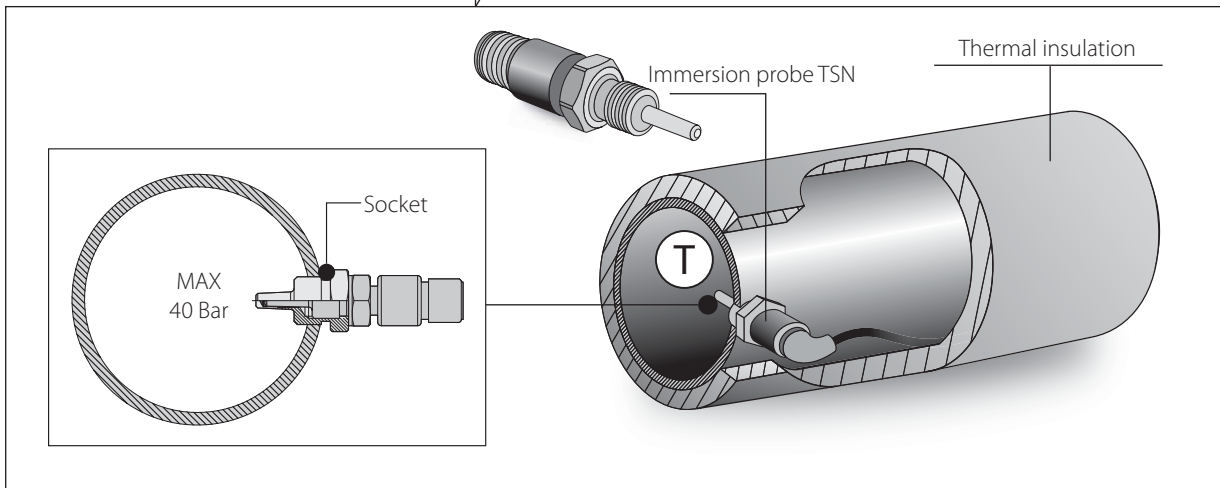
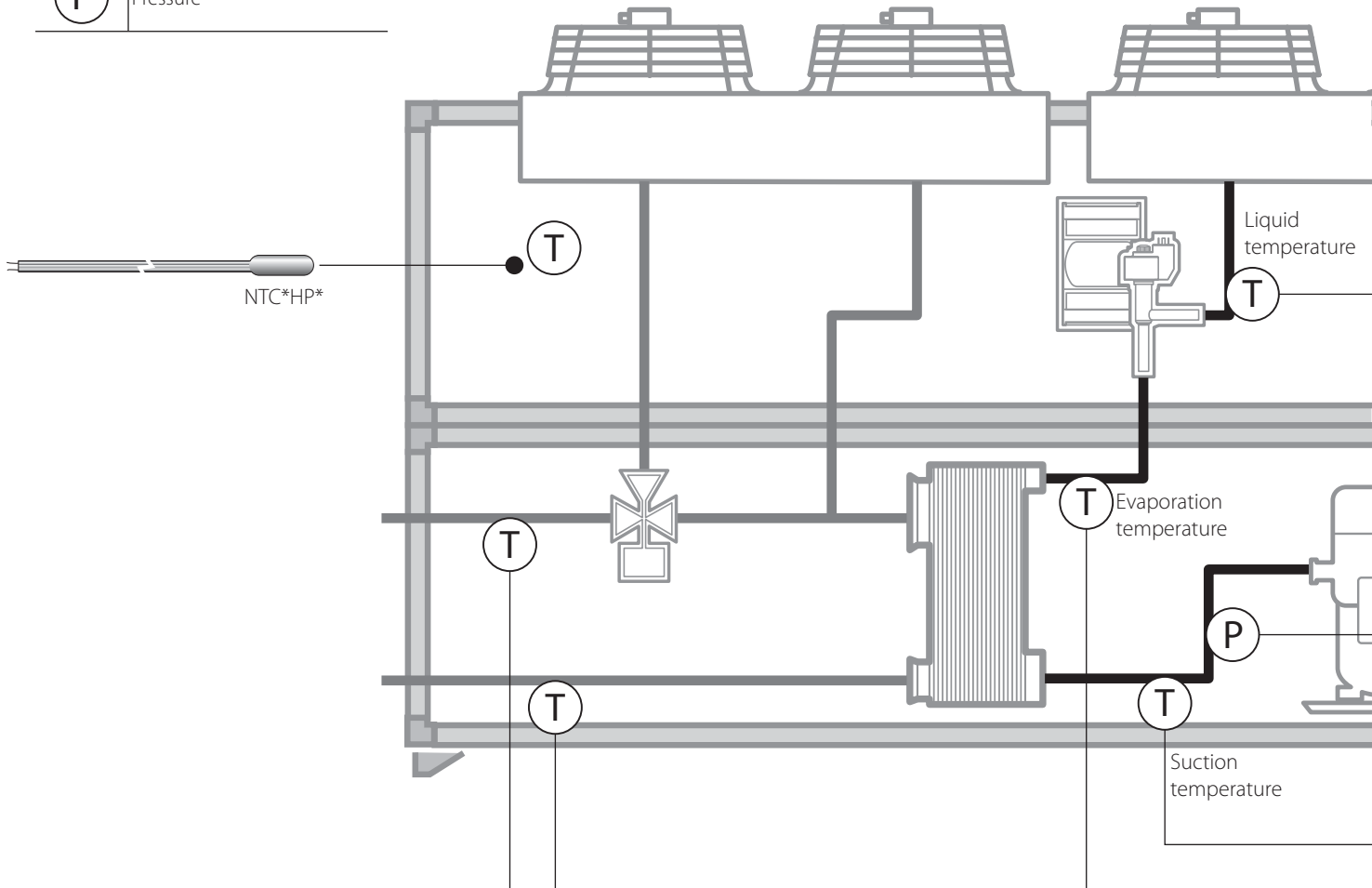

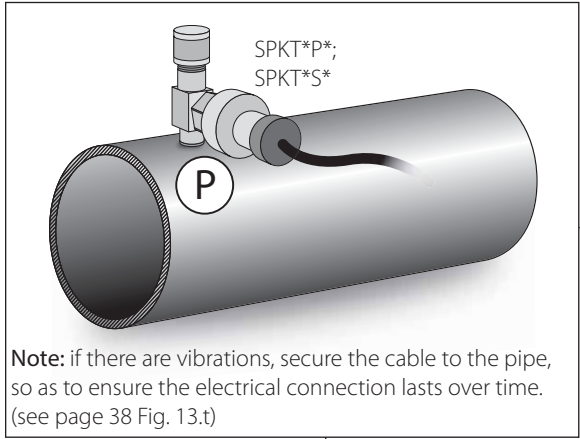

Connection with capillary

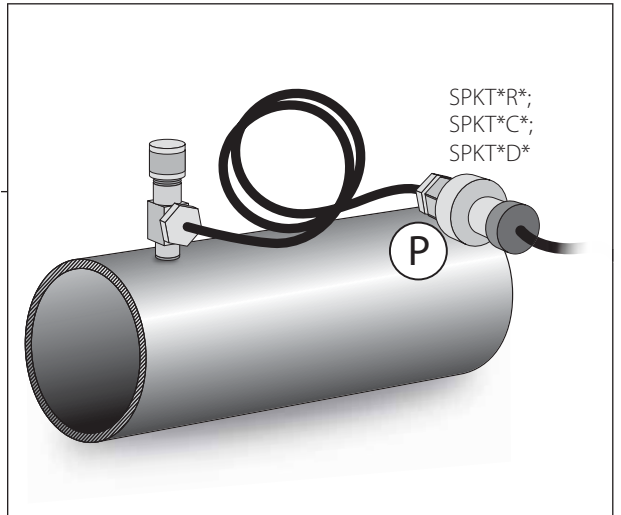

Welded connection

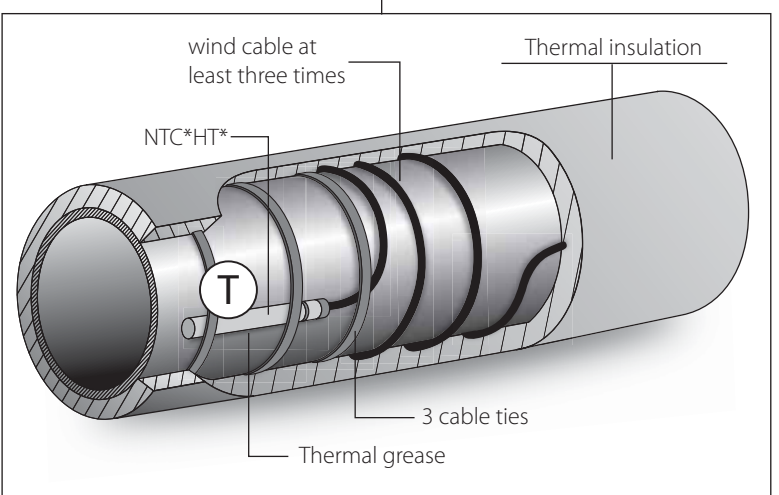
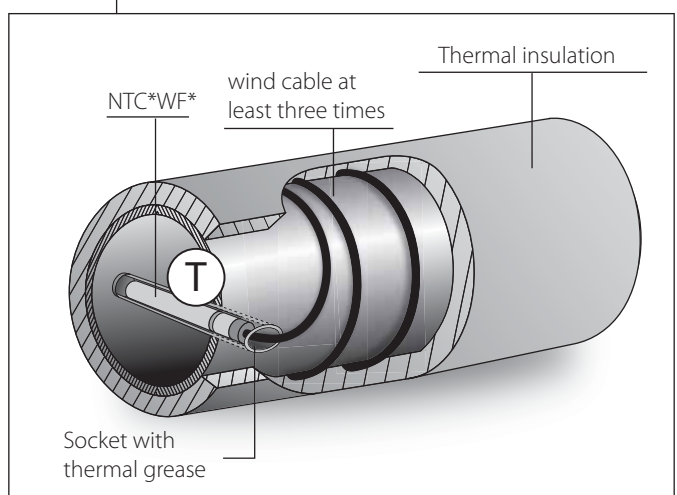
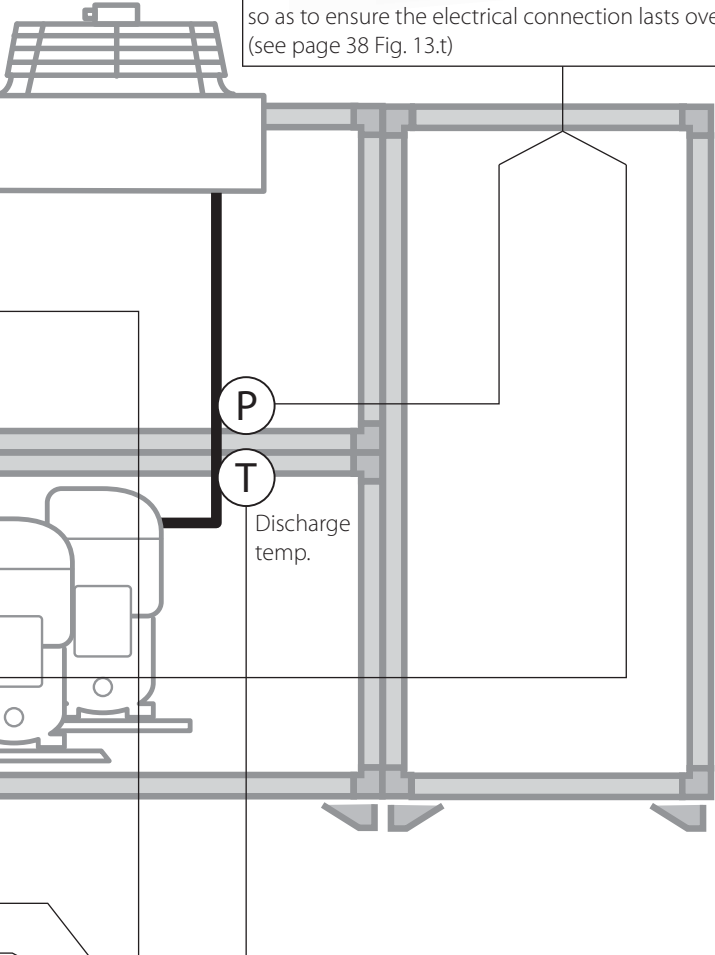
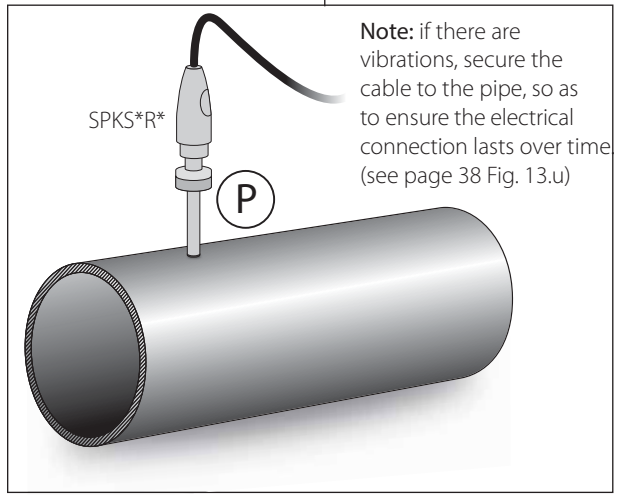

12.6 HVAC: Commercial/residential applications - Rooftop

KEY

T	Temperature
P	Pressure
rH%	Relative humidity
ΔP	Differential pressure

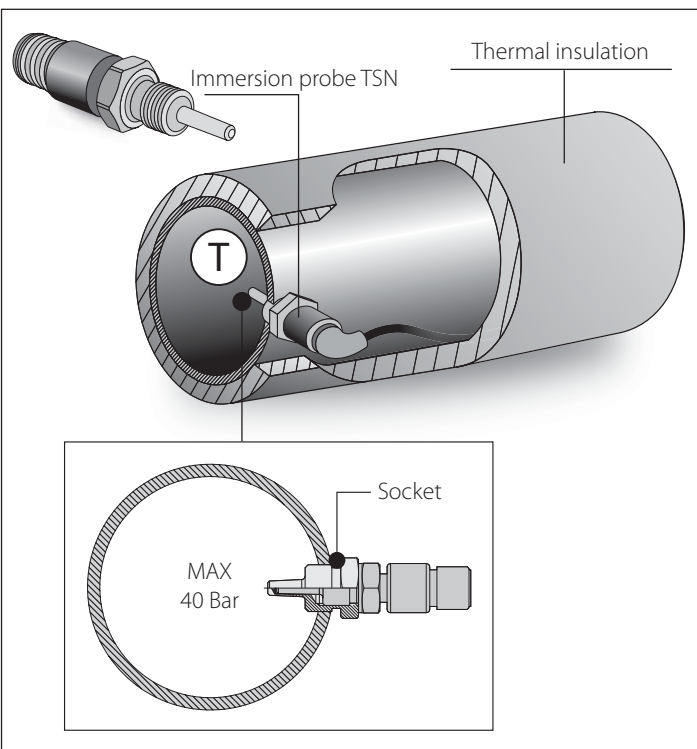
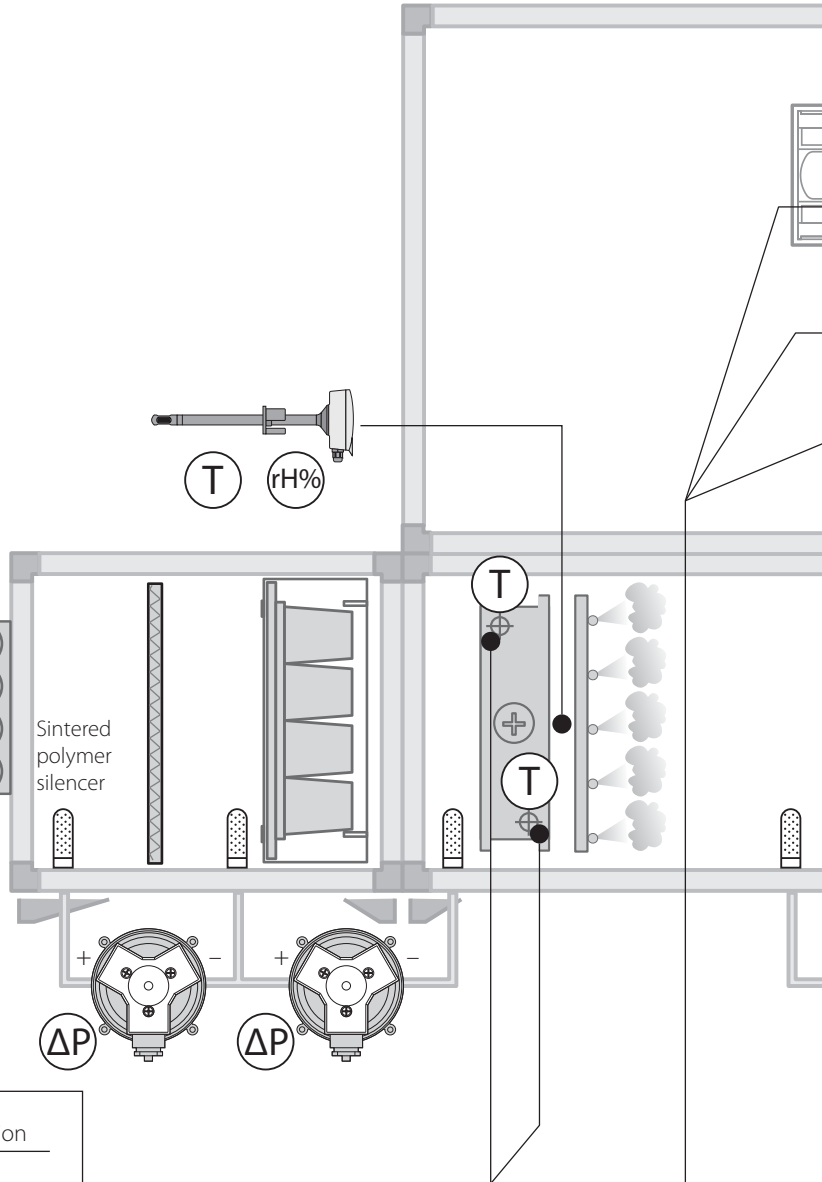
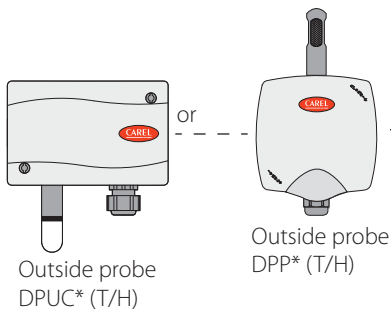

BLDC compressor

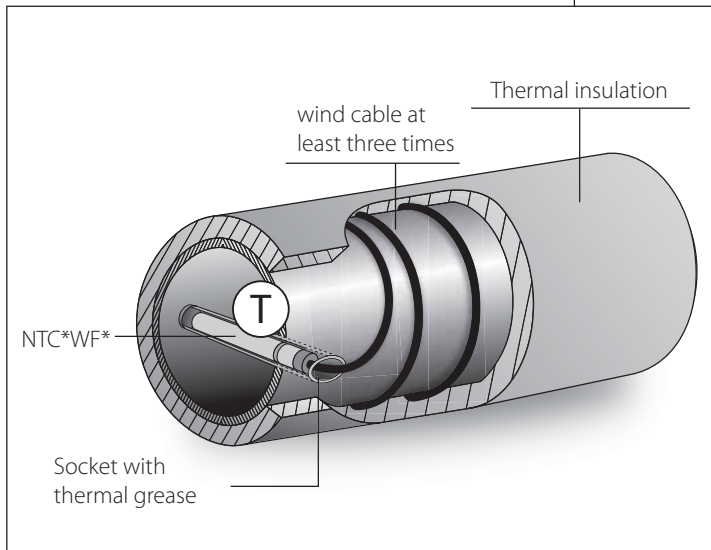

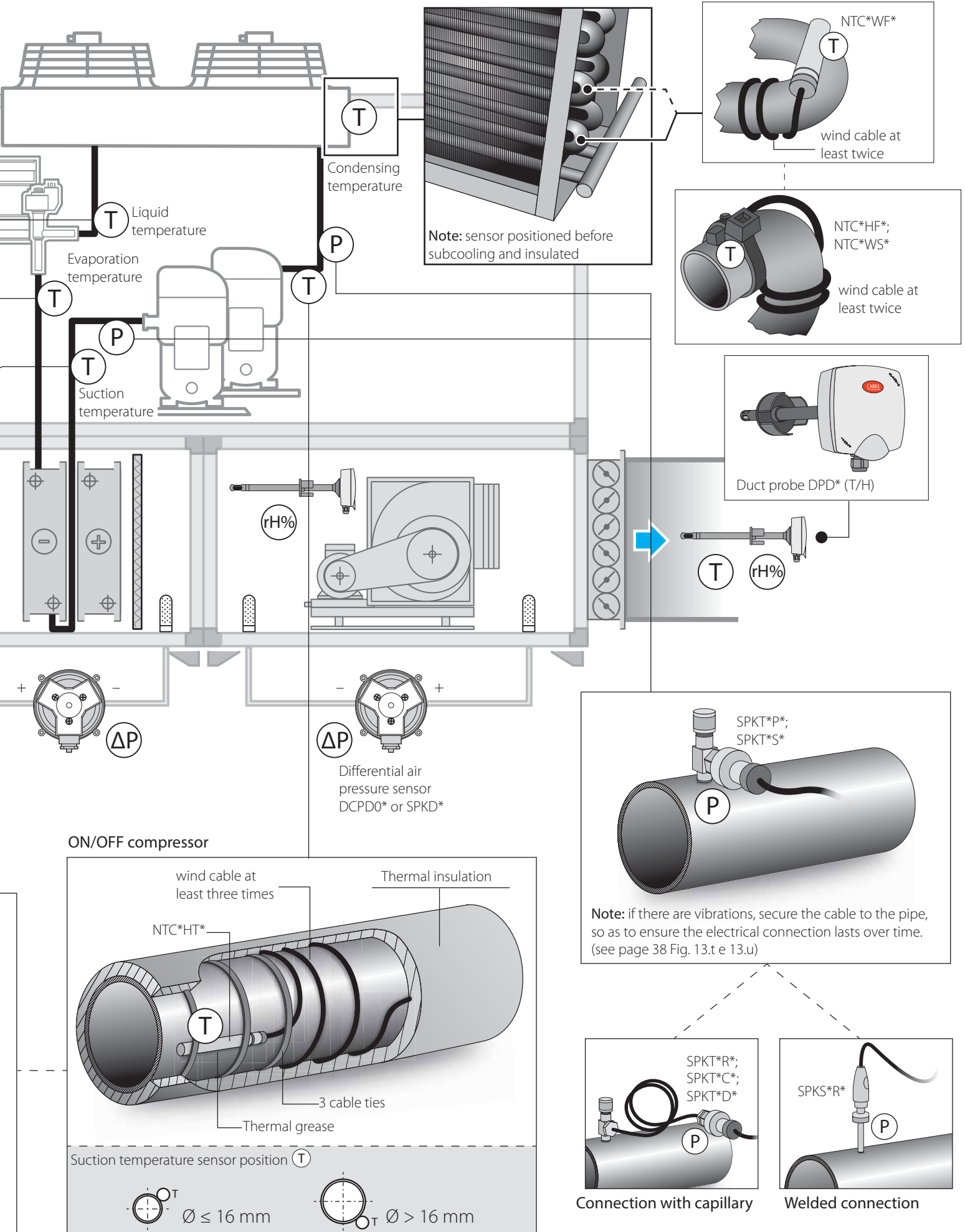

12.7 Blast chillers/freezers

KEY

T	Temperature
P	Pressure
rH%	Relative humidity

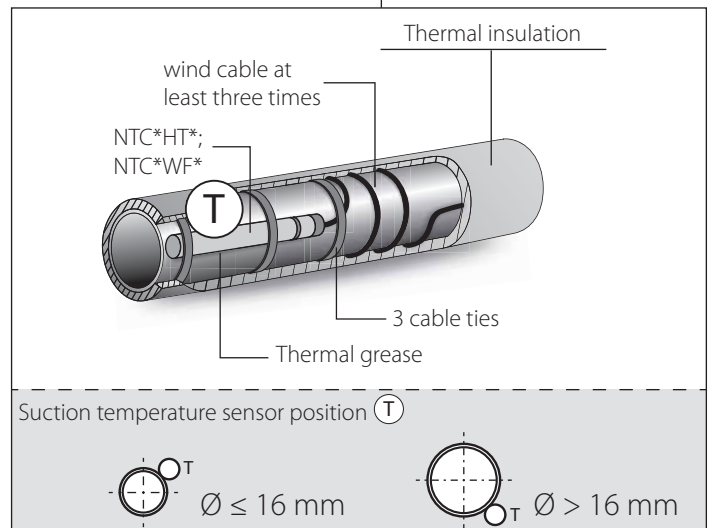
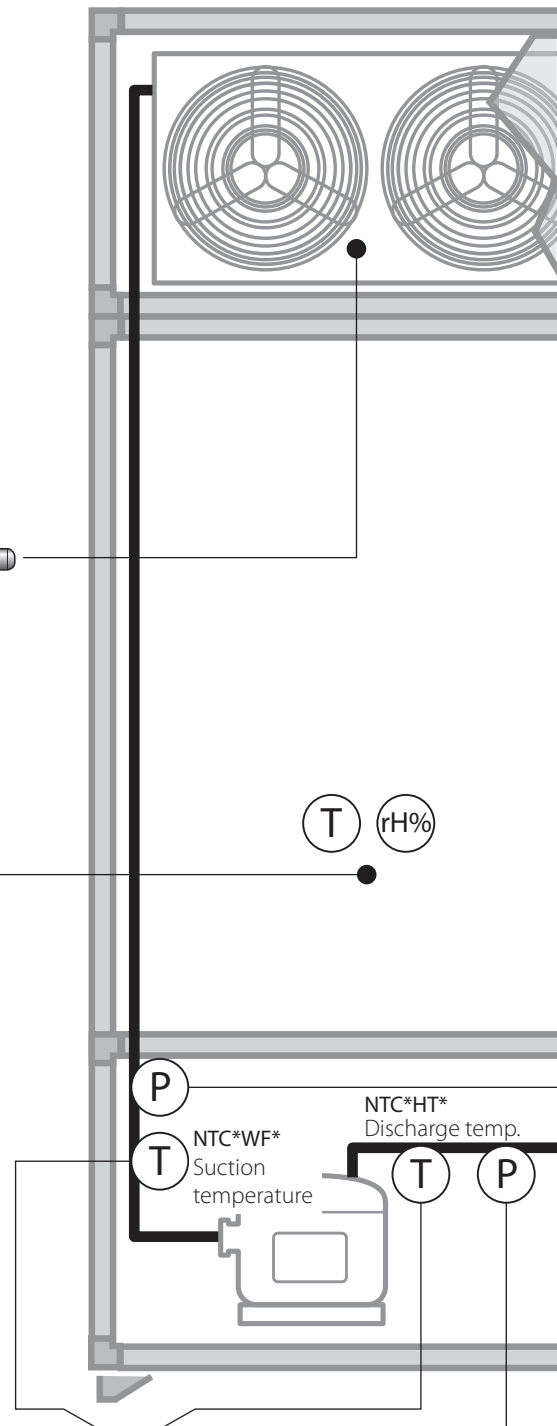
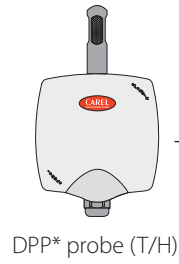
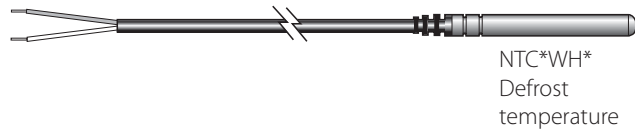

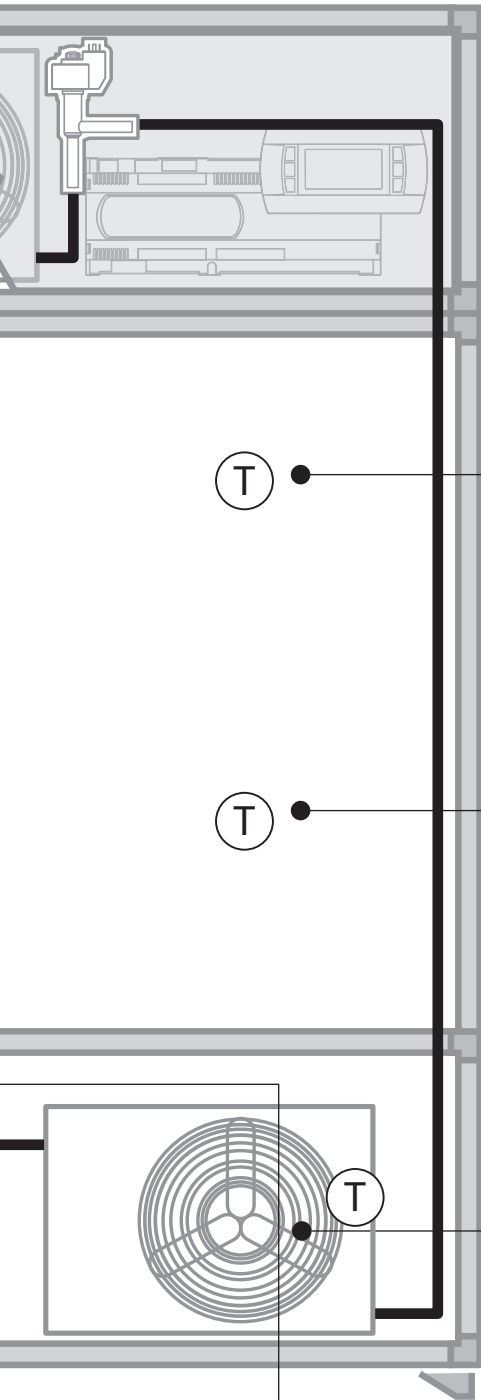

Piercing probe NTCINF610*
Product temperature

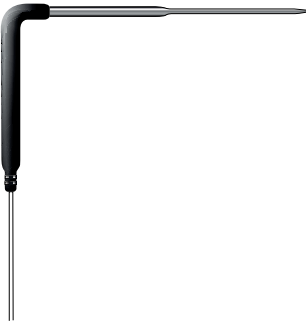

T

NTC*HP*;
NTC*HF*;
NTC*WS*



Cold room
temperature

T

Welded connection

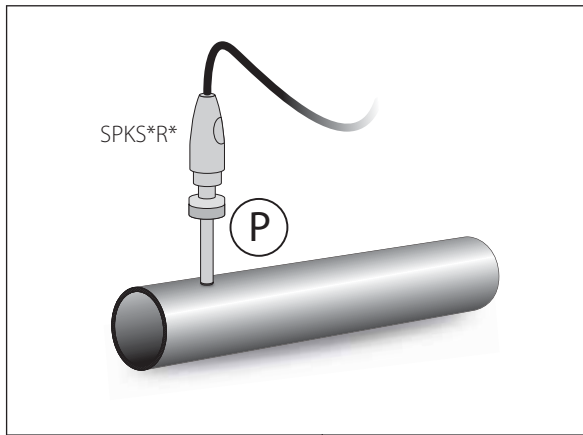

SPKS*R*

P

Condensing
temperature

T

Connection with capillary

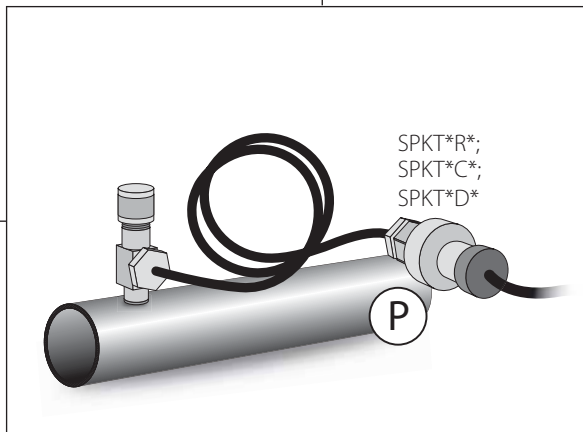

SPKT*R*;
SPKT*C*;
SPKT*D*

P

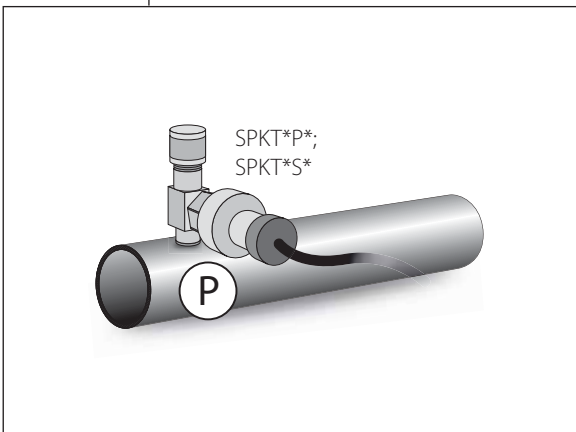

SPKT*P*;
SPKT*S*

P

12.8 Stand-alone showcases/bottle coolers

KEY

T	Temperature
P	Pressure

Welded connection

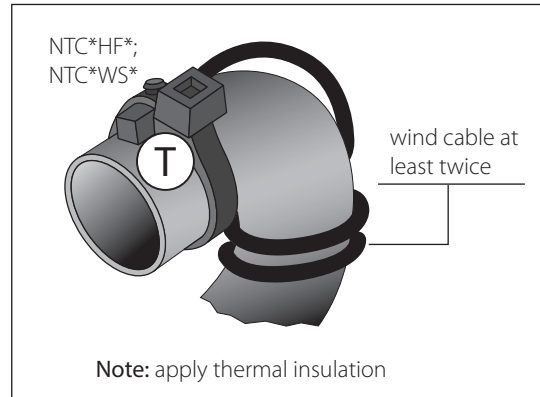
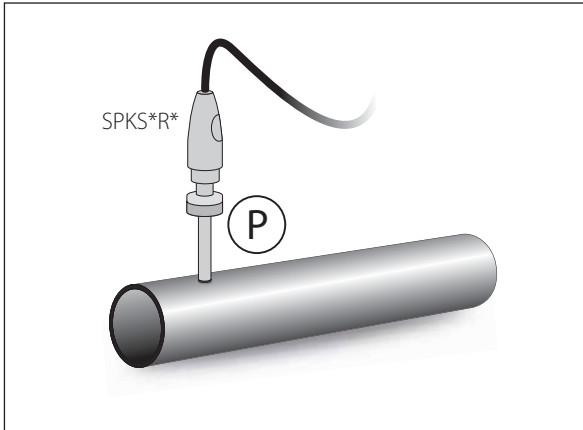

Connection with capillary

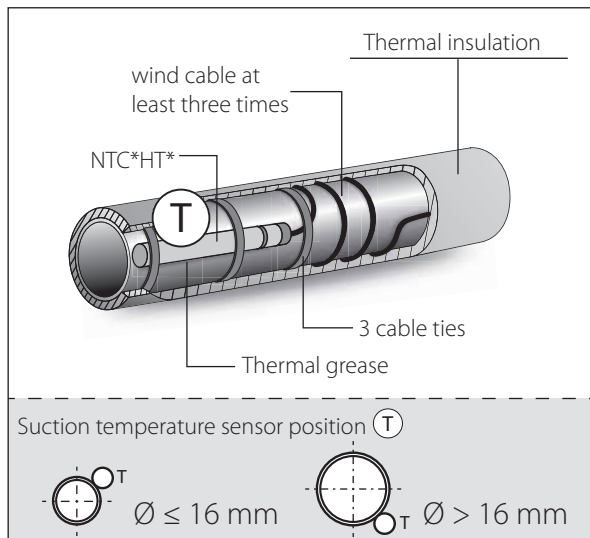
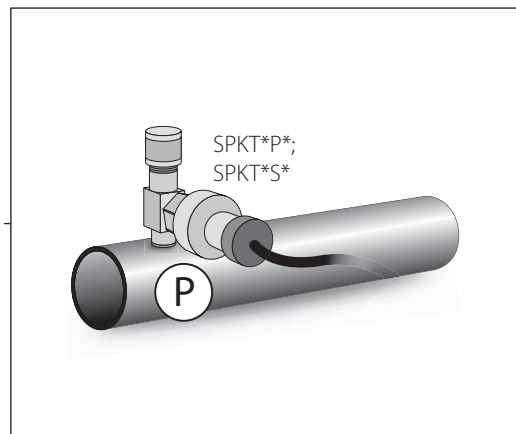
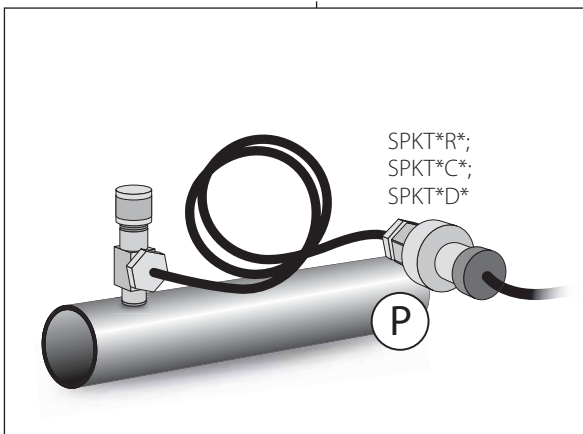

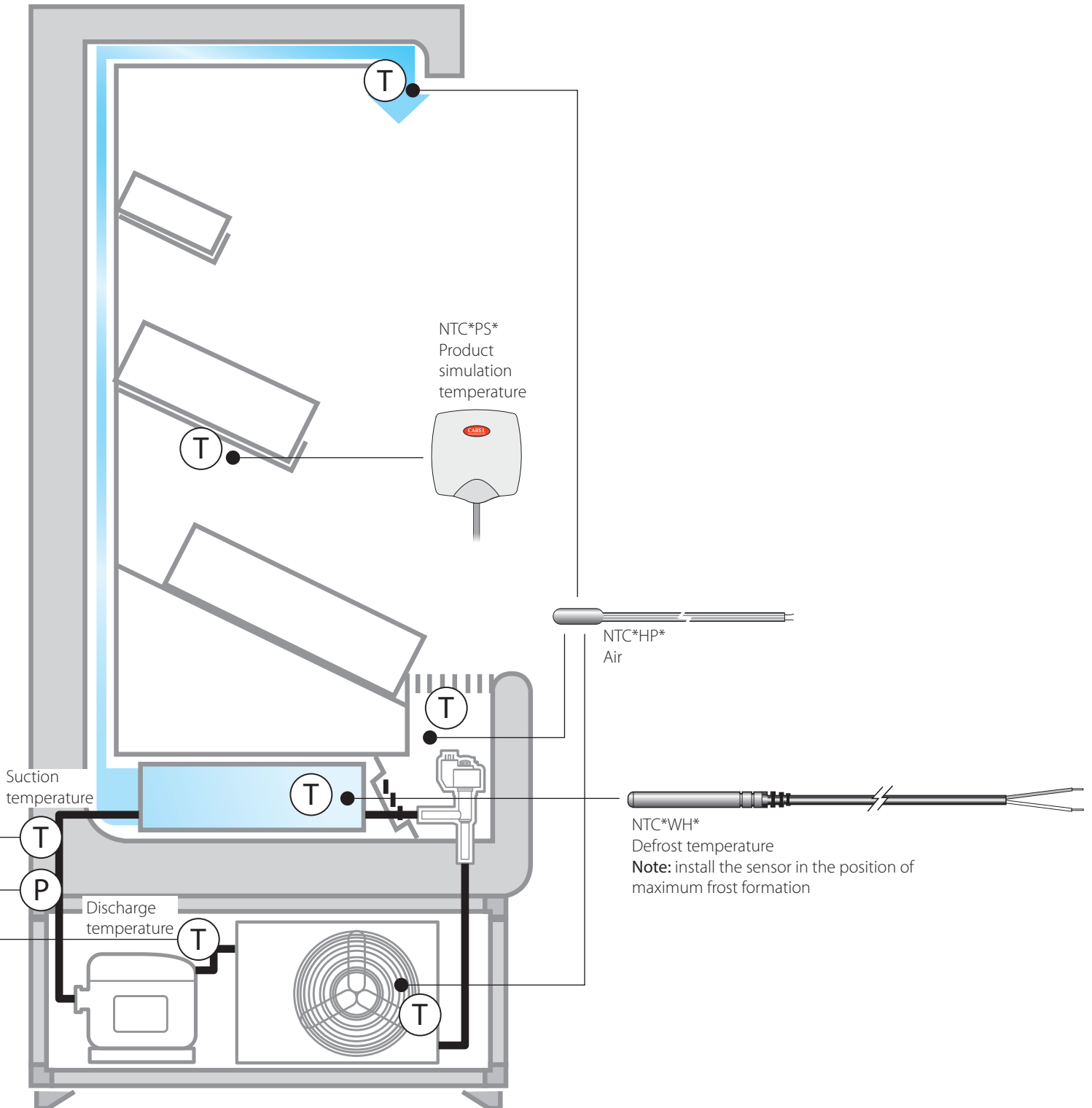

12.9 Water-cooled stand-alone showcases

KEY

T	Temperature
rH%	Relative humidity
P	Pressure

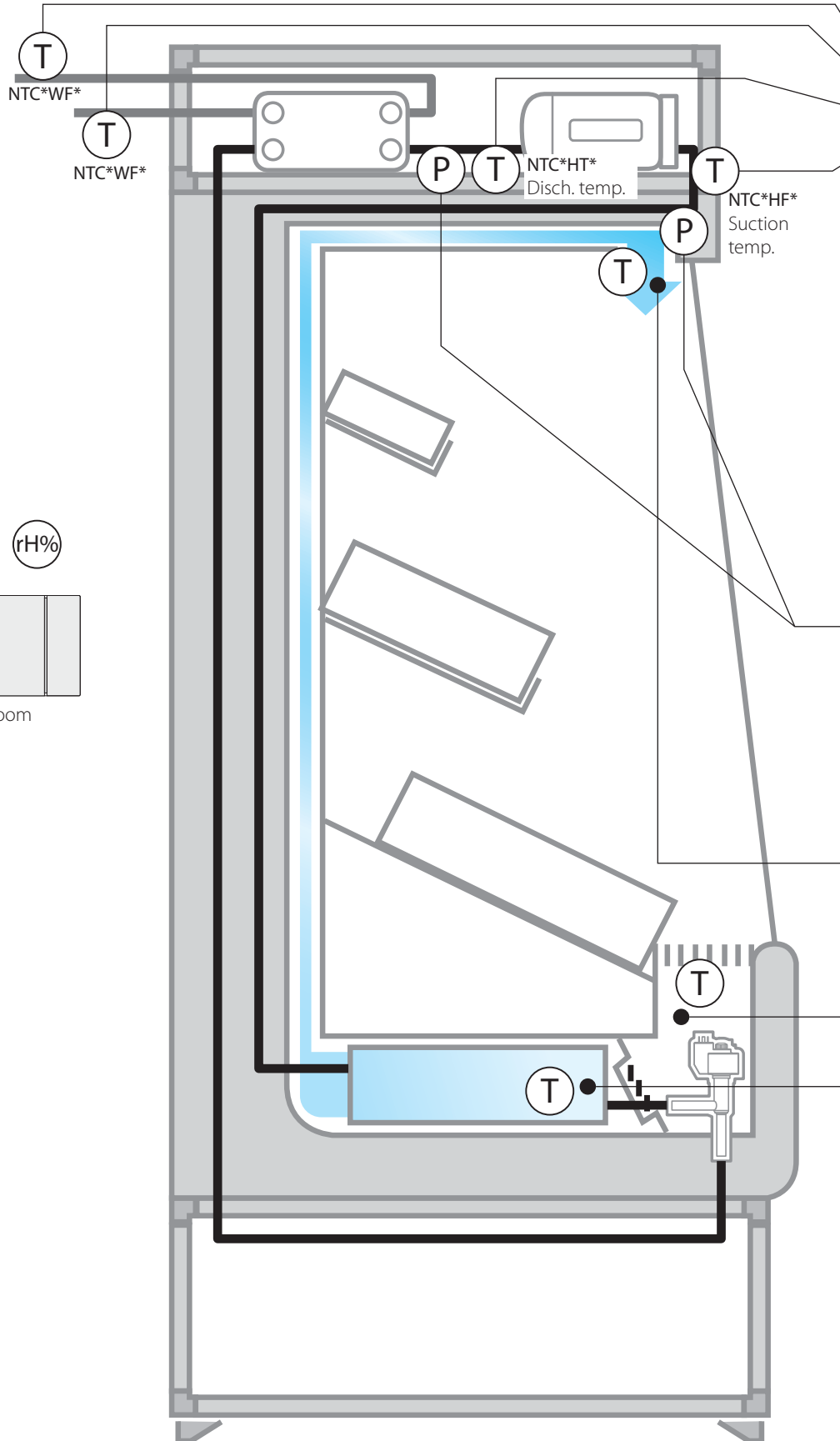
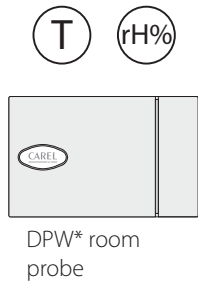

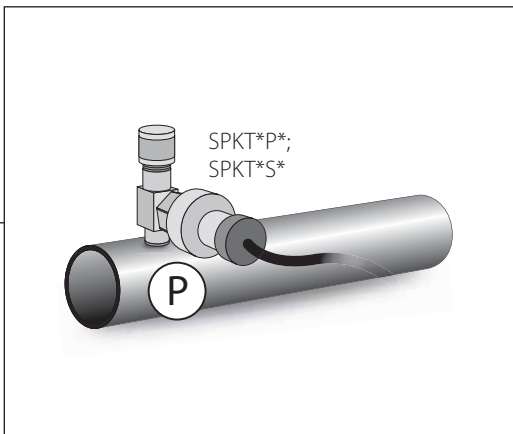
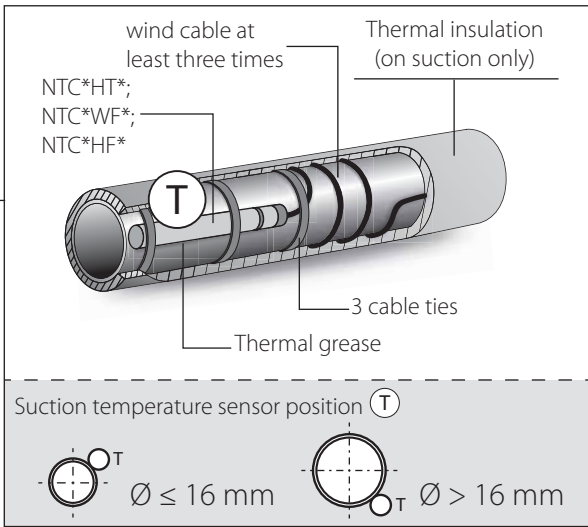

Connection with capillary

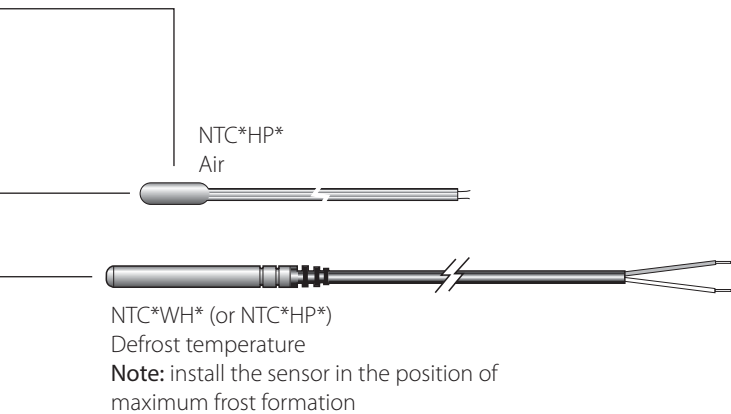
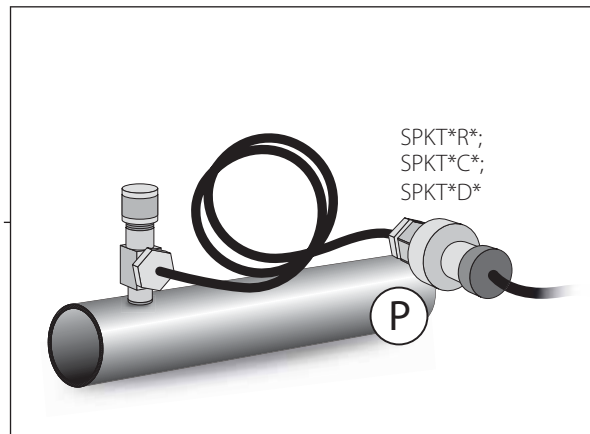

Welded connection

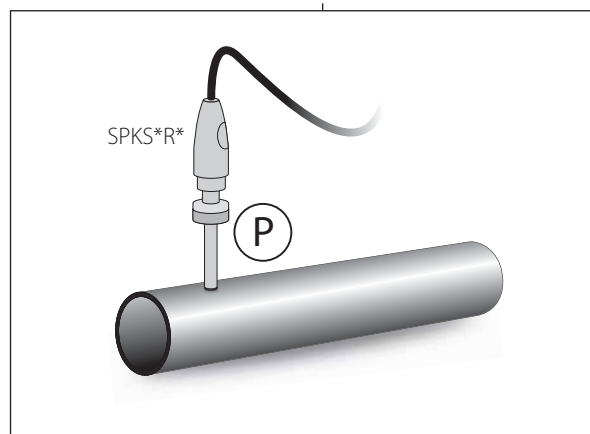

12.10 Centralised/multiplexed cabinets

KEY

T	Temperature
P	Pressure

Welded connection

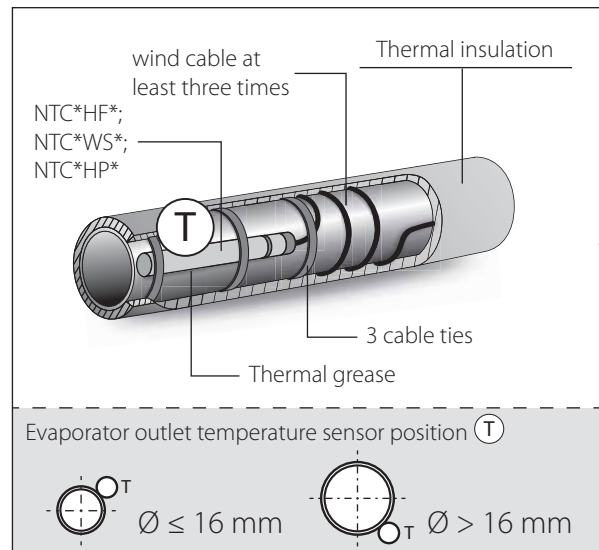
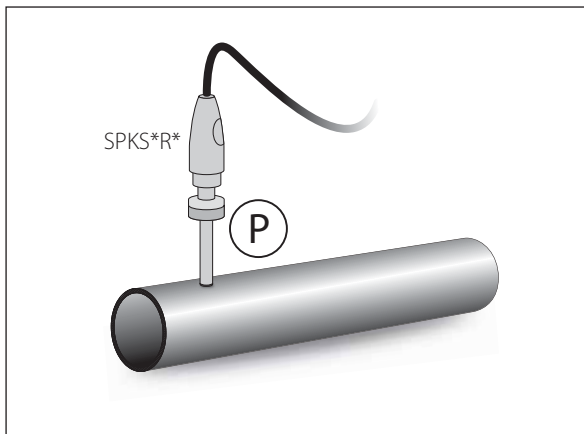

Connection with capillary

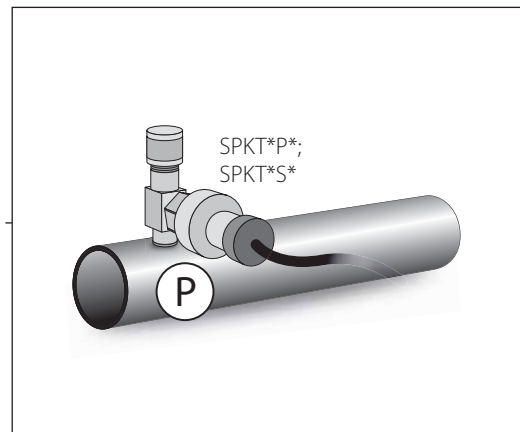
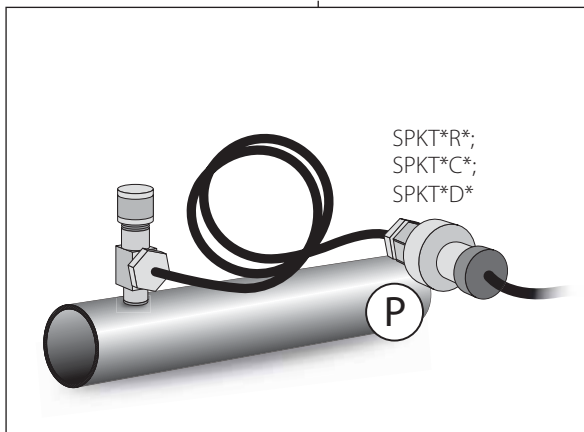

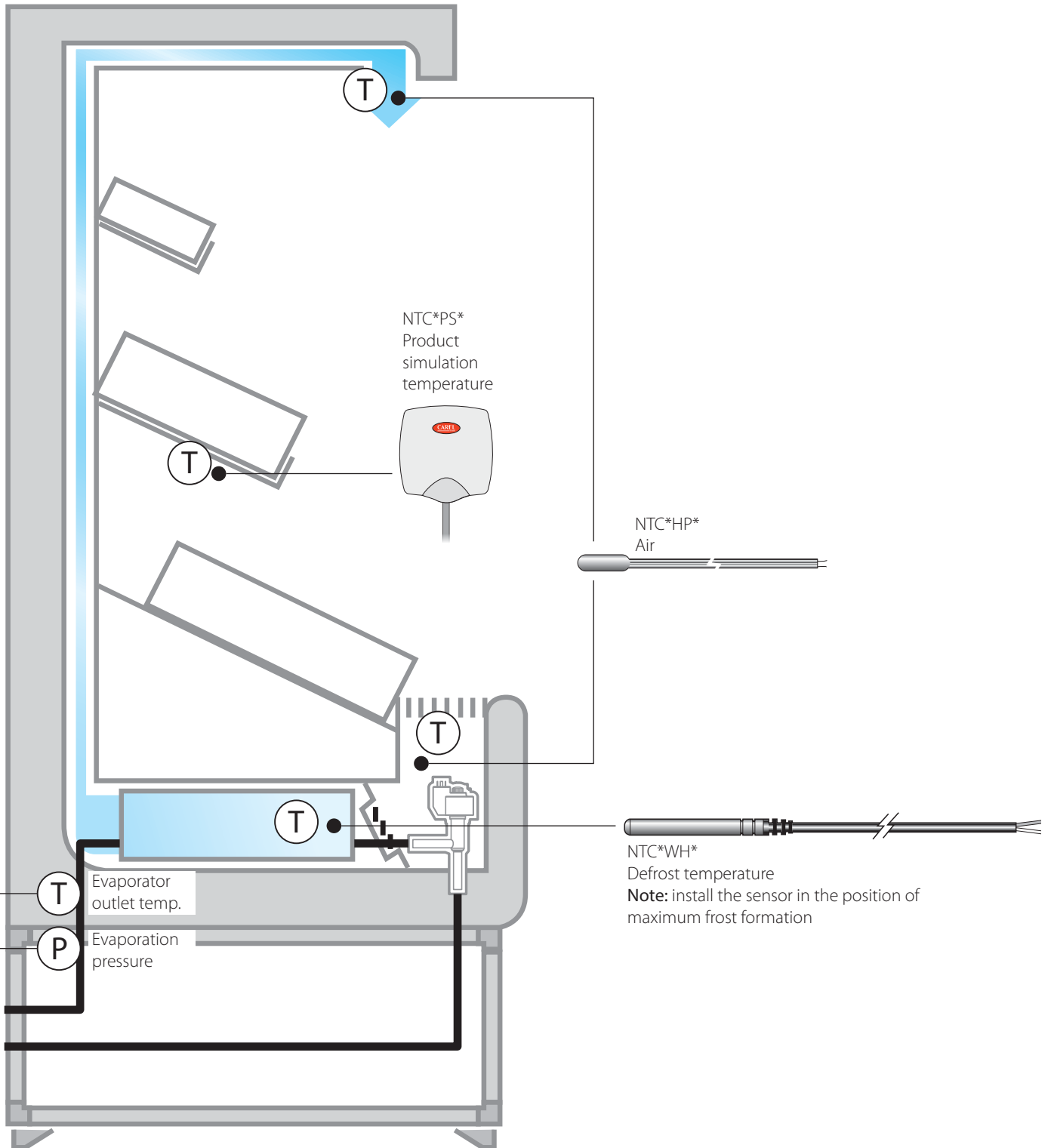

12.11 Cold rooms

KEY

(T)	Temperature
(P)	Pressure
(rH%)	Relative humidity

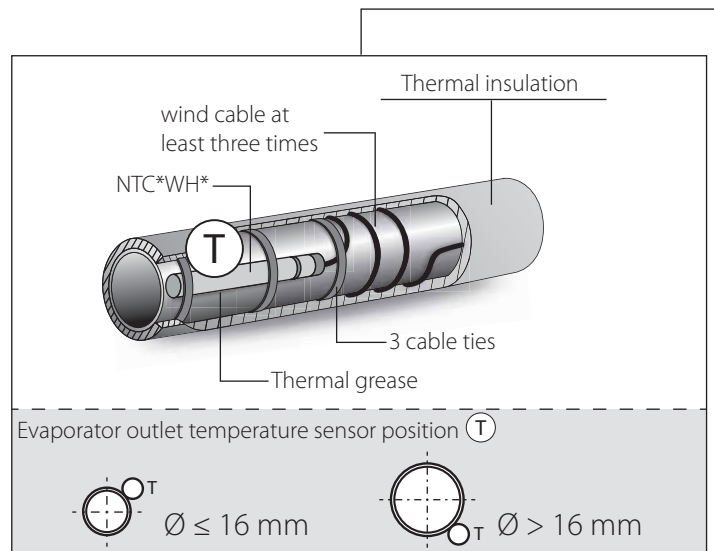
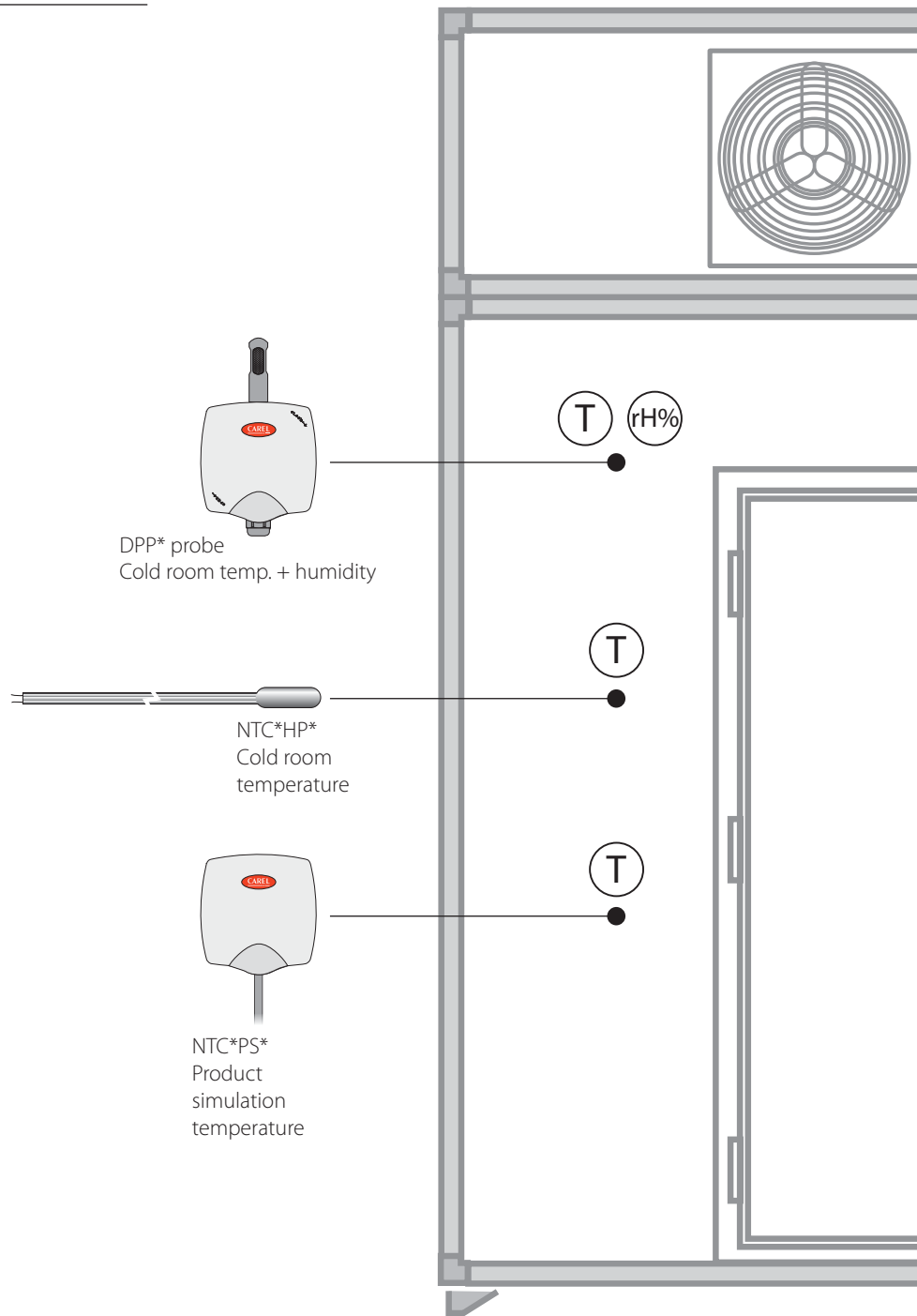

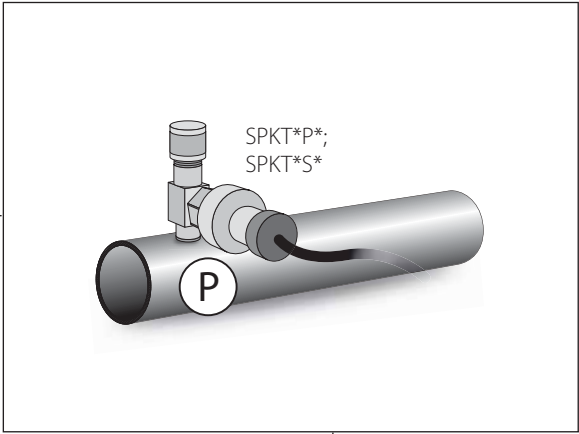
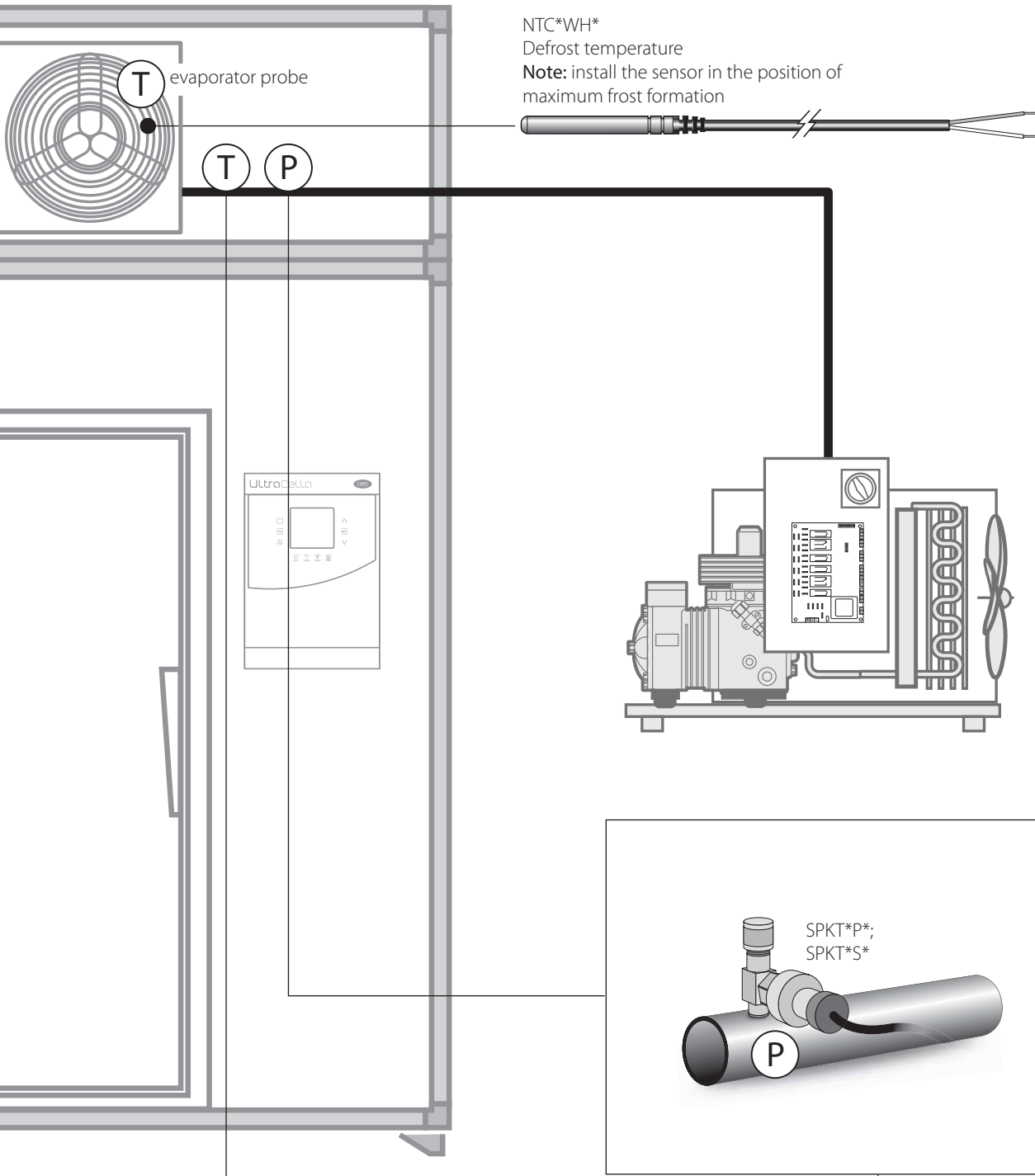

Welded connection

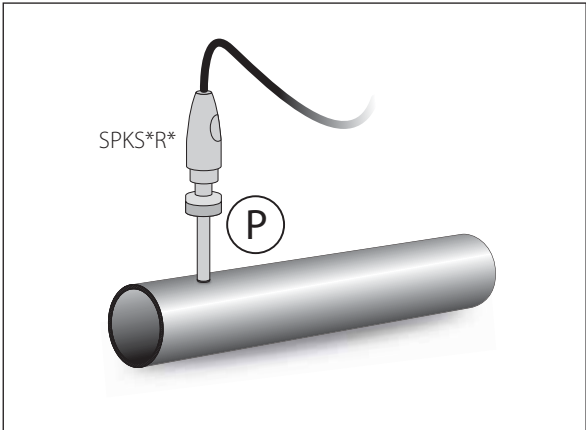

Connection with capillary

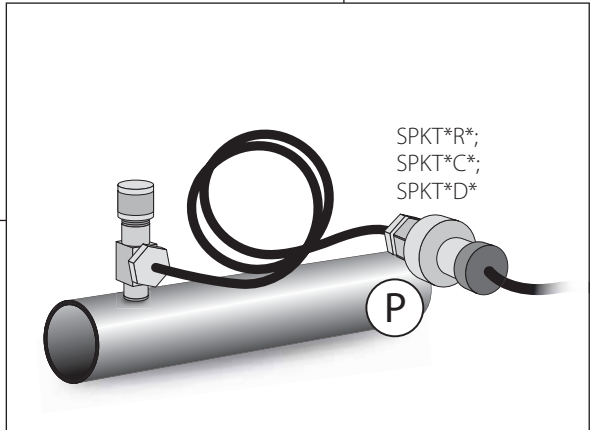

12.12 Transcritical CO₂ systems

KEY

T	Temperature
P	Pressure

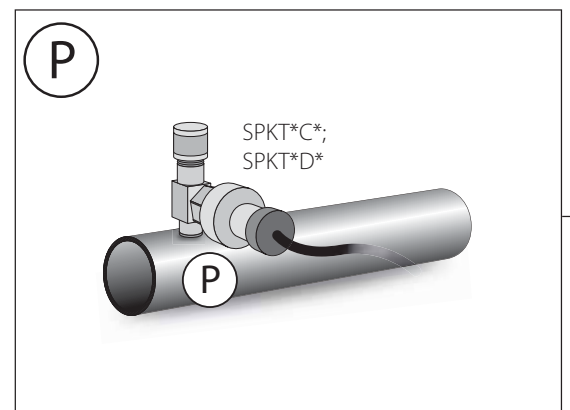
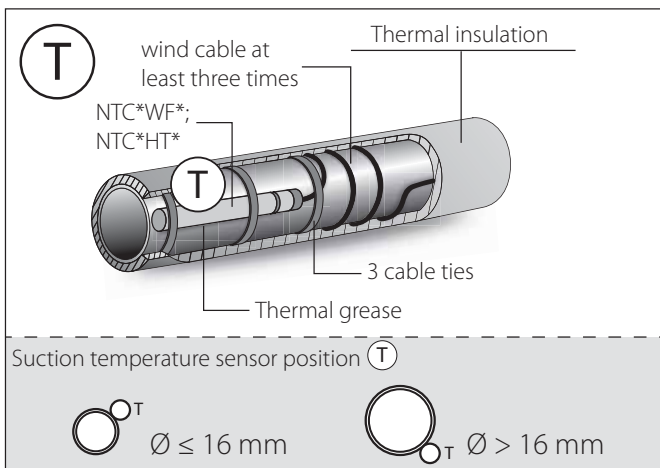
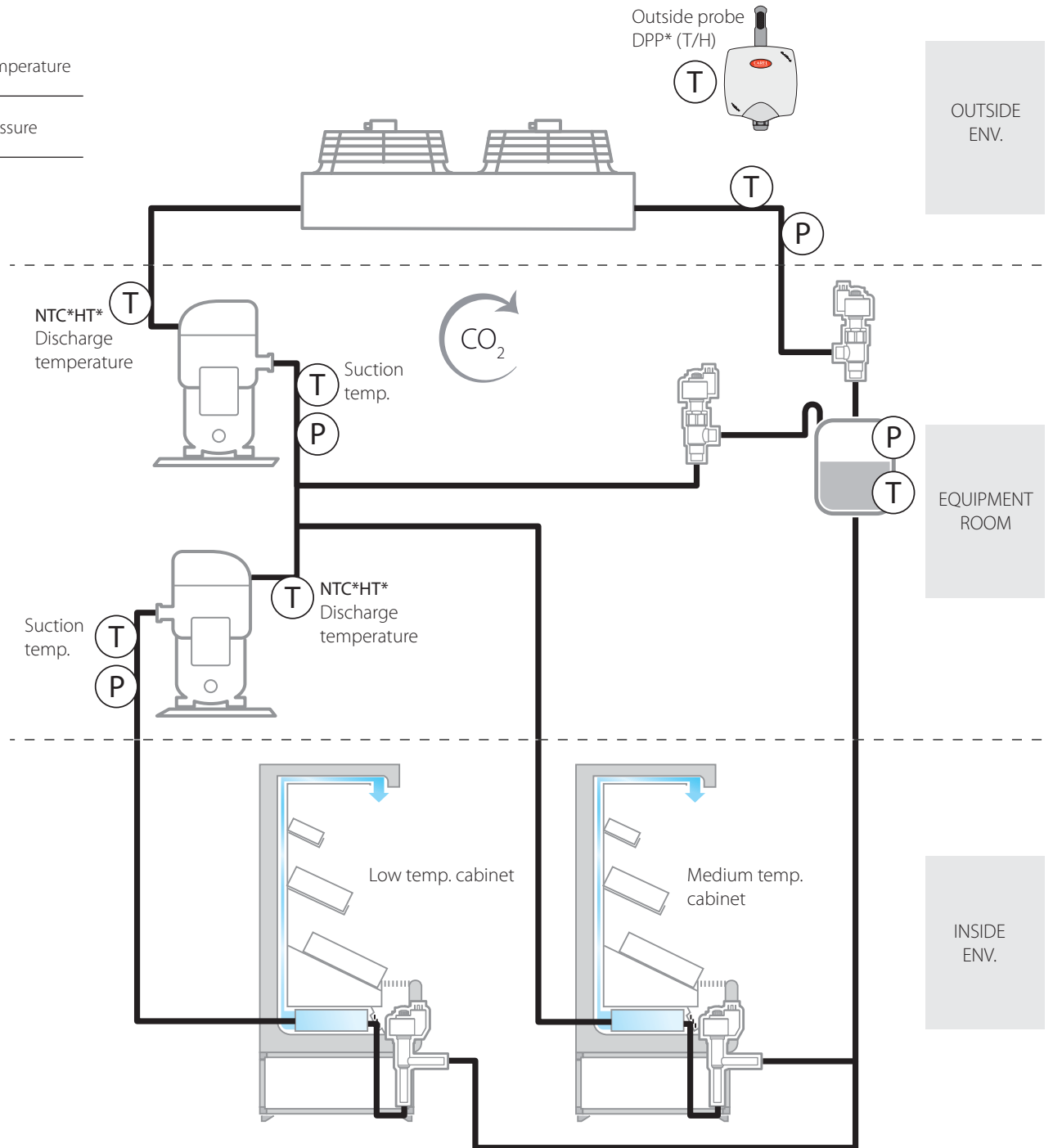

12.13 Subcritical CO₂ systems

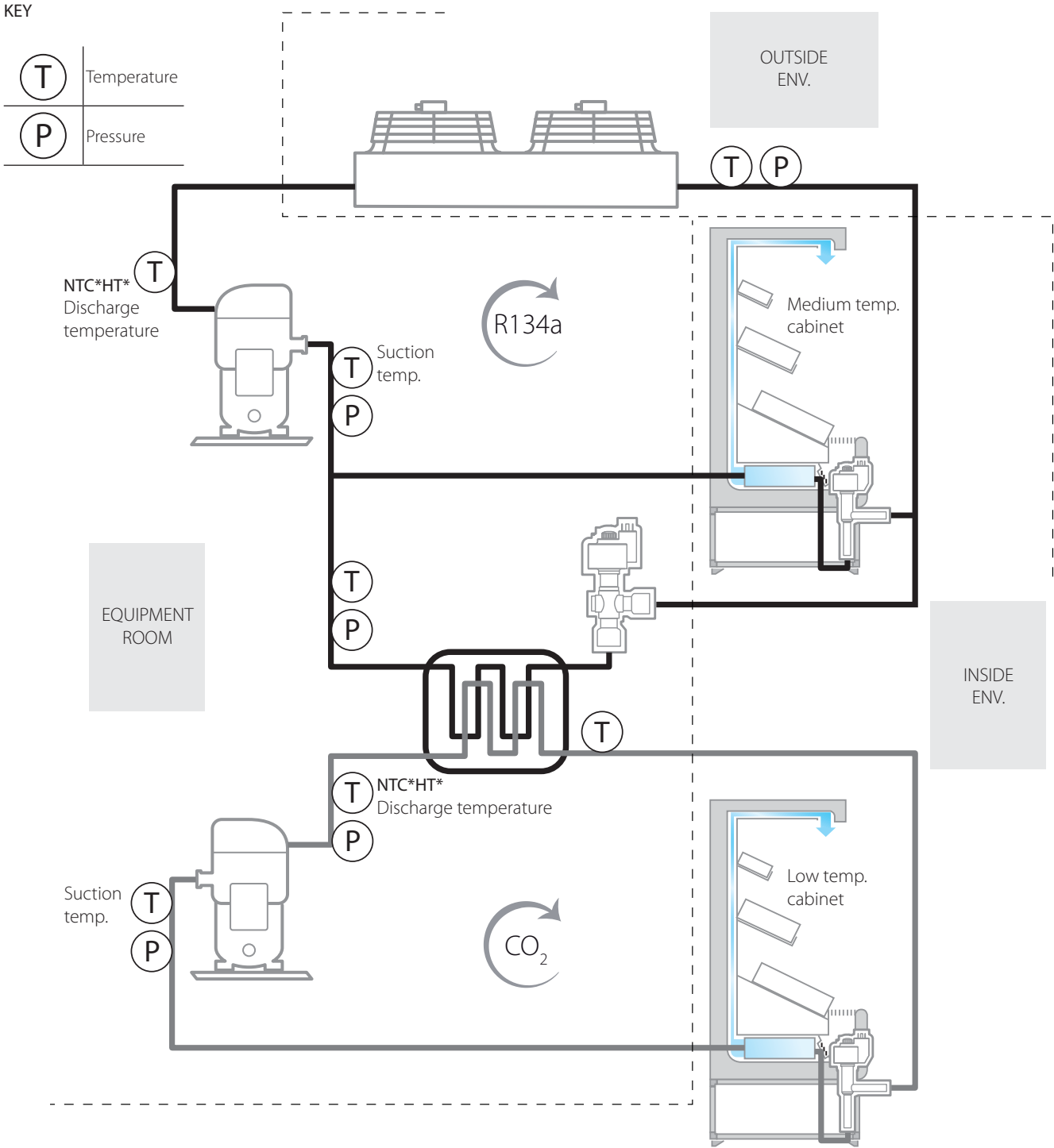

Connection with capillary

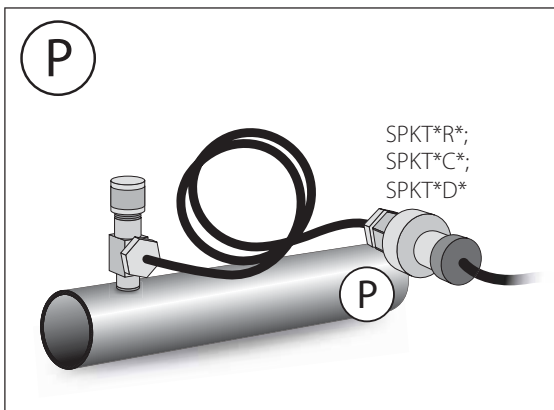

Welded connection

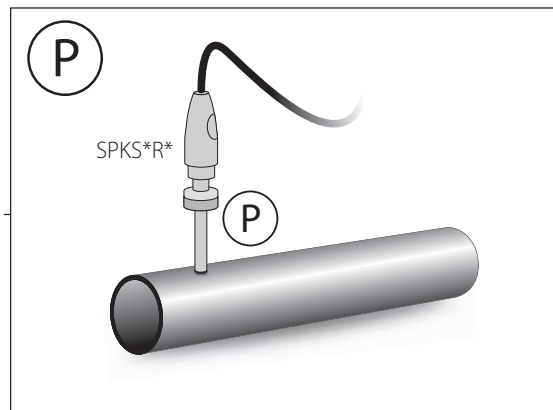

13. FURTHER SUGGESTIONS

13.1 Room temperature and humidity sensors

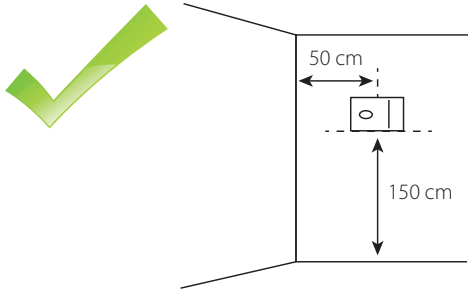

Fig. 13.a

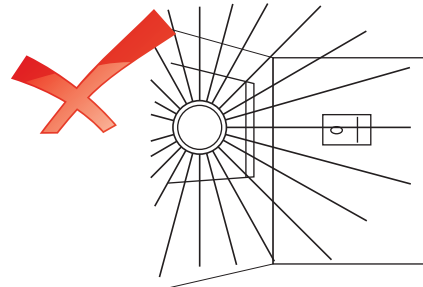

Fig. 13.b

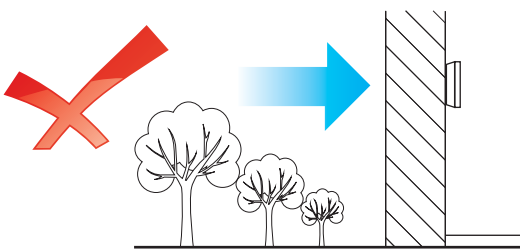

Fig. 13.c

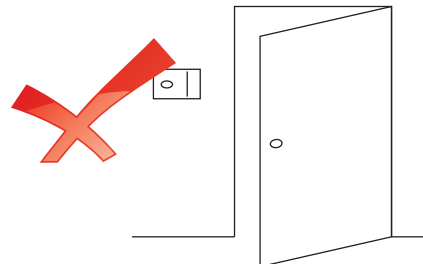

Fig. 13.d

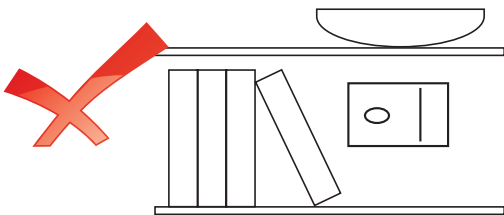

Fig. 13.e

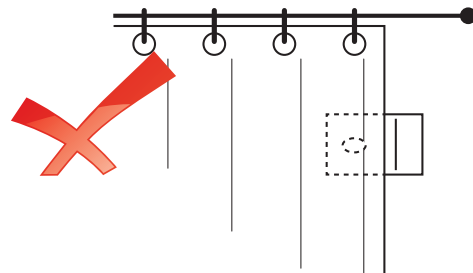

Fig. 13.f

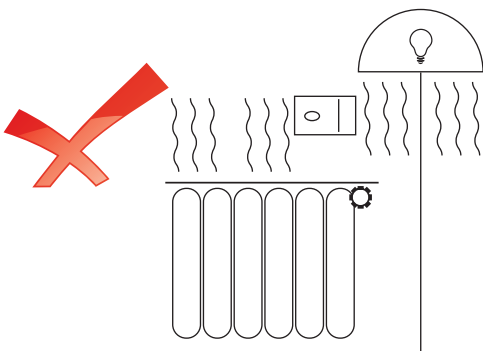

Fig. 13.g

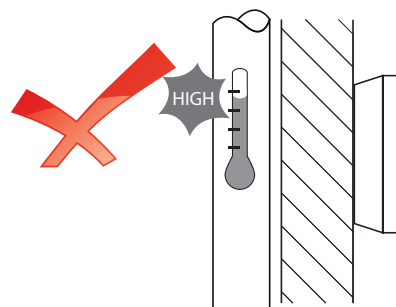

Fig. 13.h

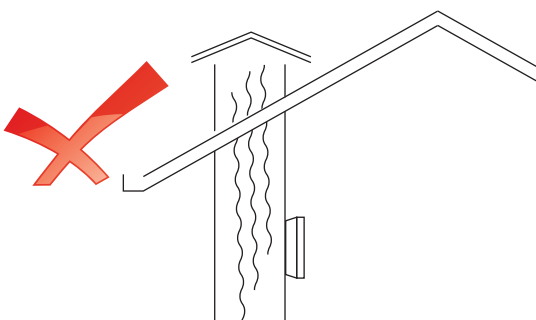

Fig. 13.i

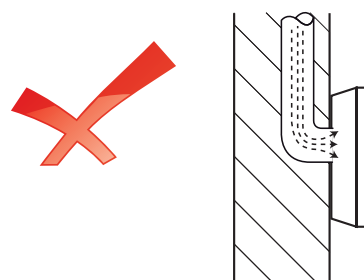

Fig. 13.l

13.2 Duct temperature and humidity sensors

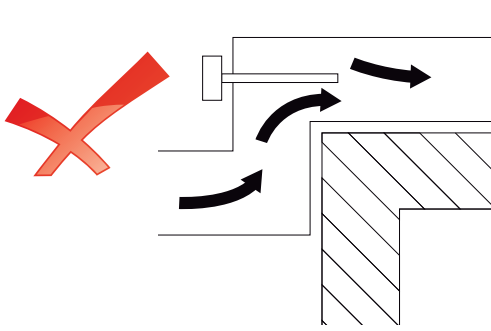

Fig. 13.m

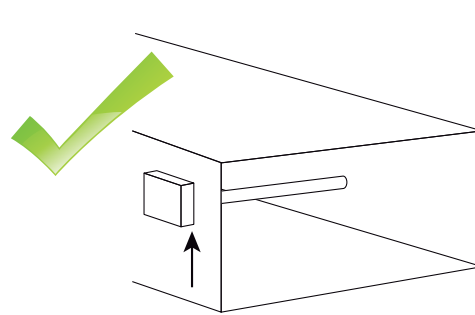

Fig. 13.n

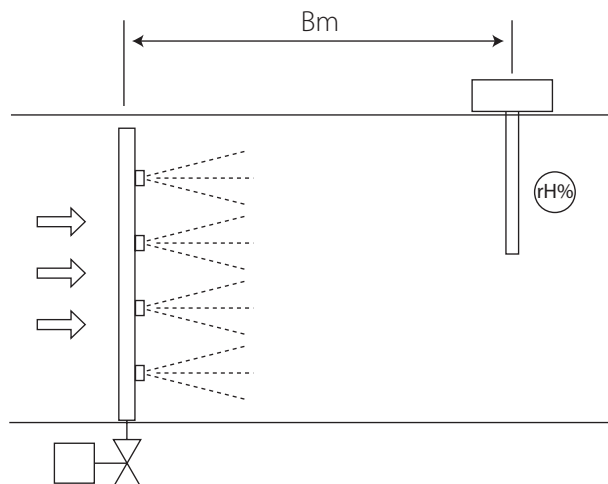
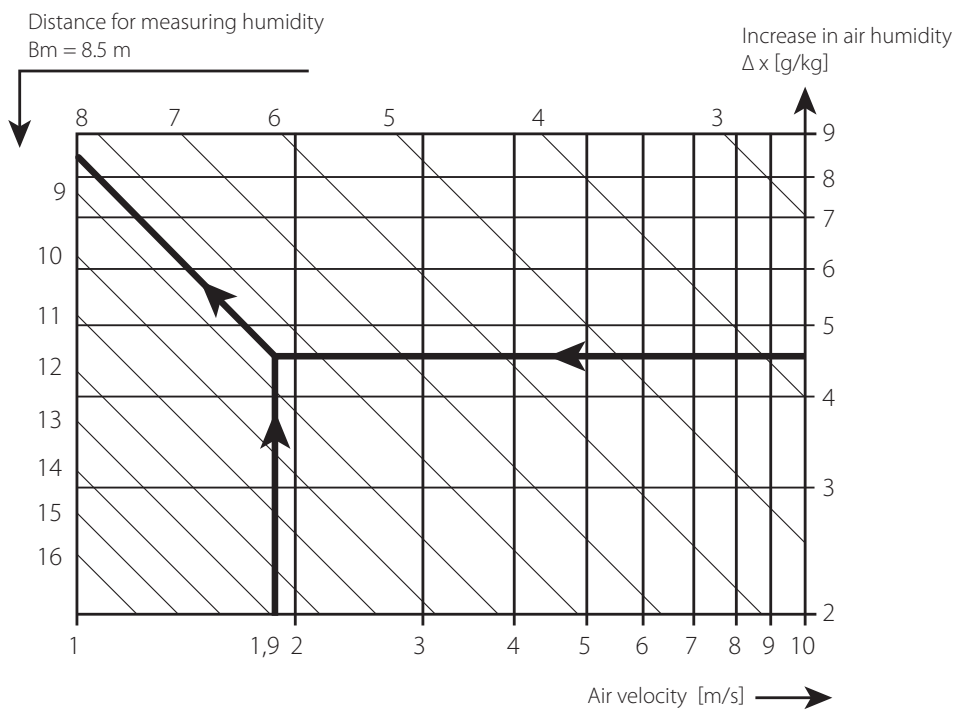

Fig. 13.o

CAREL

CAREL INDUSTRIES - Headquarters
Via dell'Industria, 11 - 35020 Brugine - Padova (Italy)
Tel. (+39) 049.9716611 - Fax (+39) 049.9716600
e-mail: carel@carel.com - www.carel.com

Agenzia / Agency: