

Date 13/5/2020
 Customer
 Offer



San Toribio, 6 28031 MADRID
 +34/913030426 com@frimetal.es

DIRECT EXPANSION EVAPORATOR

FRB-435

Model Capacity **6,4 kW**
 Required Capacity **0,0 kW**

Materials

Tubes Copper
 Fins Aluminium
 Casing Aluminun and galvanized steel white coated RAL-9002

Duties

Fin Spacing **7 mm**
 Air Flow **4170 m³/h**
 Air Velocity **1,70 m/s**
 Available Air Static Pressure **0 Pa**
 Air throw **14 m**
 Air Inlet Temperature **-20,0 °C**
 Outlet Air Temperature **-23,7 °C**
 Evaporating Temperature **-27,0 °C**
 Temperature difference DT1 **7 K**
 Refrigerant **R404A**

Options

Electrical defrost

Coil

Fin Spacing **7 mm**
 Finned Length **1700 mm**
 Surface **40,6 m²**
 Internal Volume **13,0 dm³**

Installer Information

Net weight **69 kg**
 Inlet liquid distributor **1 x 1/2"**
 Outlet line **1 x 22 mm**
 Electric defrost power **6800 W**

AC Fan motors ErP compliant

Power supply	1~230V/50Hz	Total absorbed power	240 W
Fans Nr.	3	Total absorbed current	1,1 A
Blade Diameter	300 mm	Noise Power Level	69 dB(A)
Speed	1350 rpm	Noise Pressure Level	38 dB(A)
		Distance	10 m

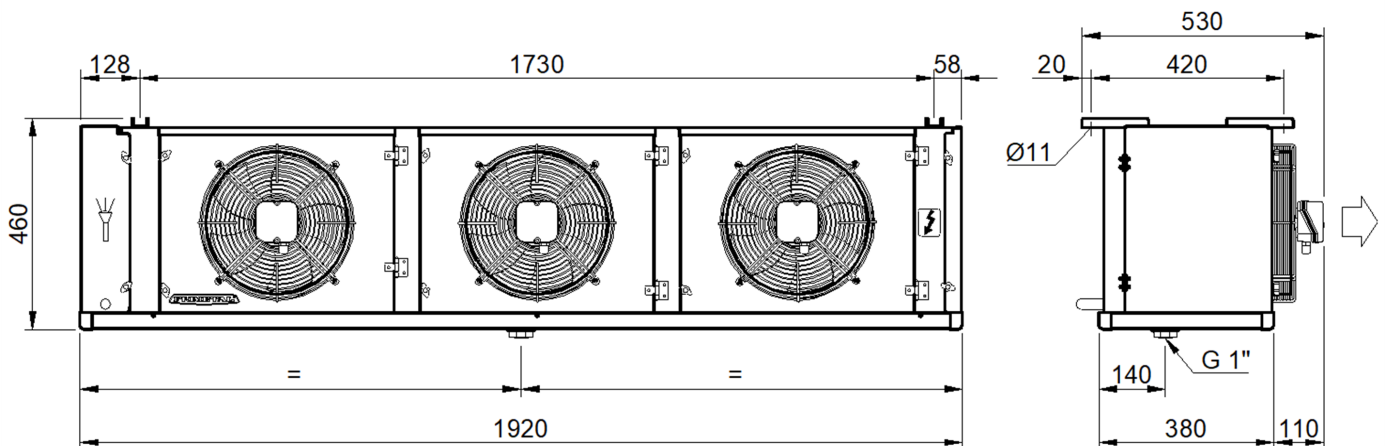

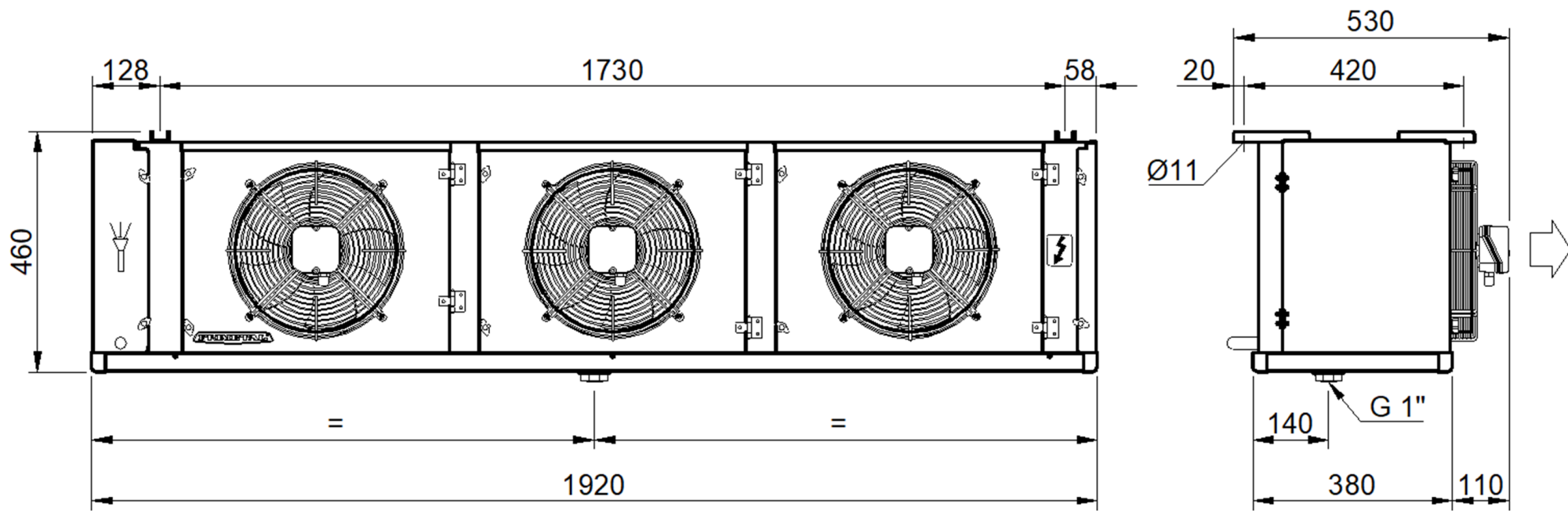

DIRECT EXPANSION EVAPORATOR - FRB-435



FRIMETAL, s.a.
 San Toribio, 6
 28031 MADRID
 +34/913030426 - +34/917774761