

## Data Sheet

Float valve  
Type **HFI**

Robust and reliable solution for high pressure control

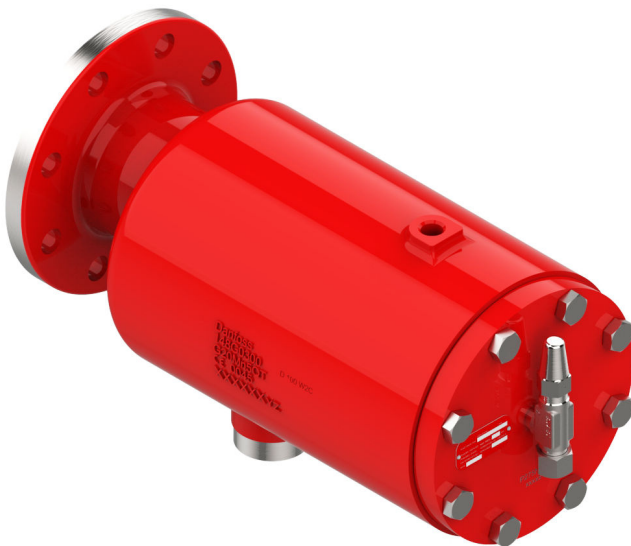

HFI is a high pressure float valve with internal liquid measuring device. The float valve is designed for direct flange mounting or welding on to plate heat exchanger type condensers, as illustrated in [Figure 1: Plate heat exchanger](#)

HFI is direct acting, therefore no differential pressure is required to activate the valve.

HFI is robust and reliable due to its simple design. The float valve is equipped with a purge valve for purging non condensable gases e.g. air from the top of the valve housing. This feature is also useful if the valve has to be serviced.

The HFI is available with two external connections on the housing for drainage and pressure equalizations.

## Features

- Designed for direct flange mounting on to plate heat exchanger type condensers
- Can be mounted directly on vessels
- Temperature range: -50 °C /+80 °C (-58 °F/+176 °F)
- Equipped with purge valve for purging non condensable gasses
- Available with external connections for drainage and pressure equalizations
- Maximum operating pressure is 25 bar (363 psig)
- Suitable for R717 (ammonia), HCFC and HFC with a density of 500 through 700 kg/m<sup>3</sup> (31.21 - 43.70 lb/ft<sup>3</sup>). For densities outside this range please contact your local Danfoss sales company.
- Housing i.e. shell and flange are made of special steel approved for low temperature application
- Classification: DNV, CRN, BV, EAC etc. To get an updated list of certification on the products please contact your local Danfoss Sales Company.

Figure 1: Plate heat exchanger

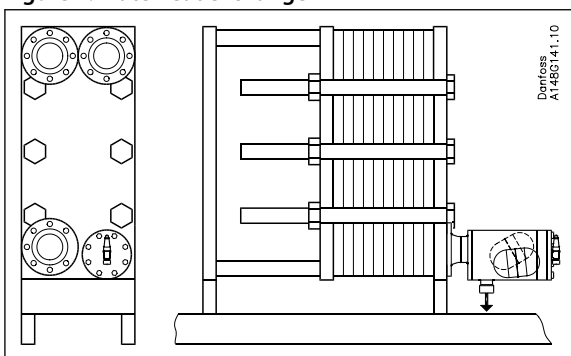

**Media****Refrigerants**

## Refrigerants

Suitable for R717 (ammonia), HCFC and HFC with a density of 500 through 700 kg/m<sup>3</sup> (31.21 - 43.70 lb/ft<sup>3</sup>). For densities outside this range please contact your local Danfoss sales company.

Flammable hydrocarbons are not recommended. For further information please contact your local Danfoss Sales Company.

**New refrigerants**

Danfoss products are continually evaluated for use with new refrigerants depending on market requirements.

When a refrigerant is approved for use by Danfoss, it is added to the relevant portfolio, and the R number of the refrigerant (e.g. R513A) will be added to the technical data of the code number. Therefore, products for specific refrigerants are best checked at [store.danfoss.com/en/](https://store.danfoss.com/en/), or by contacting your local Danfoss representative.

## Product specification

### Design

#### Housing

Housing i.e. shell and flange is made of special steel approved for low temperature operation.

#### Installation

Refer to installation instruction for HFI.

Figure 2: Identification:

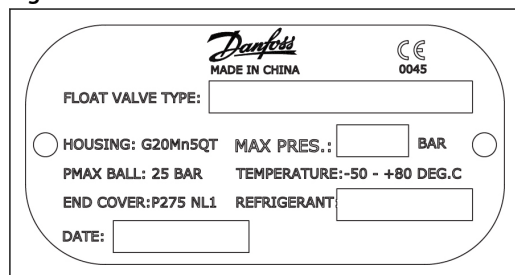

### Pressure and temperature data

Table 1: Pressure and temperature

Description	Values
Temperature range	-50 °C / +80 °C (-58 °F / +176 °F)
The float valve is designed for: Maximum operating pressure	Housing PED 28 bar (407 psig) Ball (float) 25 bar (363 psig)

If test pressure exceeds 25 bar (363 psi g) the ball should be removed during test.

Valves for higher pressure are available on request.

### The principle of high pressure control

#### Introduction

In installations with one application high pressure control is an effective and cost saving way of expanding liquid from the condenser to the low pressure side.

High pressure refrigerant entering the condenser will start to condense, consequently condensate will accumulate at the bottom of the condenser and in the float valve.

When capacity demands increase, the liquid level in the float valve will rise, which will cause the valve to open and the refrigerant to expand into the separator at the low pressure side.

When the valve is closed, there will still be a small by-pass over the seat, so any remaining liquid will equalize slowly to the low pressure side, for instance during an off cycle. Therefore the system will equalize automatically and the compressor can start up without excessive back pressure. The size of the bypass is predetermined and defined by geometry of the elements.

It follows from the above, that almost all the refrigerant will be accumulated on the low pressure side under normal conditions. Therefore under normal conditions no high pressure receiver is necessary when using the HFI for high pressure control.

## Insert for the high pressure float valve

Figure 3: Detail A Fully closed

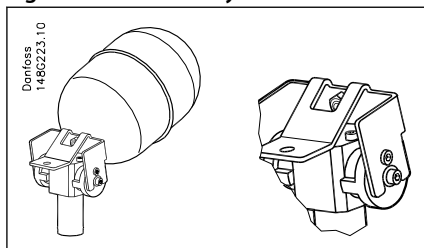
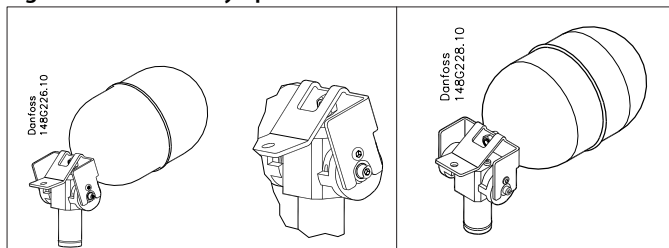

Figure 4: Detail B Fully open



### Computation and selection

In R 717 plants (ammonia)

On the following pages you will find tables with capacities of the float valve at various operating conditions.

Select a valve using the specific operating conditions. The chosen valve must have a capacity higher than the required capacity during nominal operation, as well as during plant start up.

In plants using other refrigerants than ammonia

The capacity of the float valve can be calculated by using the values and the equation to the right. However, the density of the refrigerant must be in the range: 500 to 700 kg/m<sup>3</sup>.

For densities outside this range please contact your local Danfoss Sales Company.

Table 2: Valve capacity values

Valve type	Nominal capacity [kW] (R 717, -10/+35°C)	Valve constant [K]
HFI 040 FD	400	16.79
HFI 050 FD	800	33.58
HFI 060 FD	1200	50.36
HFI 070 FD	2400	100

Mass flow

$$G = K\sqrt{\Delta p \times \rho}$$

[kg / h]

$\Delta p$  differential pressure [bar]

$\rho$  density of liquid [kg/m<sup>3</sup>]

K valve constant (from the above table)

### Computation and selection capacity tables - SI units

Table 3: HFI 040 - R 717, evaporating capacity [kW]

Condensing temp. (°C)	Evaporating temperature (°C)												
	-40	-35	-30	-25	-20	-15	-10	-5	0	5	10	15	20
50	475	480	480	475	475	475	470	460	455	445	430	415	395
45	460	460	460	460	455	455	445	440	430	420	405	385	360
40	440	440	440	440	435	430	425	415	405	390	375	350	325
35	420	420	420	415	415	405	400	390	375	360	340	315	280
30	400	400	400	395	390	385	375	360	345	325	300	270	230
25	380	380	375	370	365	360	345	330	315	290	260	220	160
20	360	355	355	350	340	330	315	300	280	250	210	155	
15	340	335	330	325	315	300	285	265	240	200	150		
10	315	310	305	295	285	270	250						
5	290	285	280	270	255	240	215	225					
0	270	260	255	240	225	205	175	185	195	140			
-5	245	235	225	210	190	165	125	125					
-10	220	210	200	180	155	115							

## Float valve, type HFI

**Table 4: HFI 050 - R 717, evaporating capacity [kW]**

Condens- ing temp. (°C)	Evaporating temperature (°C)												
	-40	-35	-30	-25	-20	-15	-10	-5	0	5	10	15	20
50	955	955	955	955	950	945	935	925	910	890	865	830	790
45	920	920	920	915	910	905	895	880	860	835	805	770	725
40	880	880	880	875	870	860	850	830	810	780	745	700	645
35	845	845	840	835	825	815	<b>800</b>	780	755	720	680	625	560
30	805	800	800	790	780	765	750	725	695	655	605	540	455
25	765	760	755	745	730	715	695	665	630	580	520	440	320
20	720	715	705	695	680	660	635	600	555	500	420	310	
15	675	670	660	645	630	605	570	530	480	405	295		
10	630	625	610	595	570	545	505						
5	585	575	560	540	515	480	430	455	385	285			
0	540	525	505	485	450	405	365	385	270				
-5	490	475	455	425	385	325	345	255					
-10	440	420	395	360	305	230	240						

**Table 5: HFI 060 - R 717, evaporating capacity [kW]**

Condens- ing temp. (°C)	Evaporating temperature (°C)												
	-40	-35	-30	-25	-20	-15	-10	-5	0	5	10	15	20
50	1430	1435	1435	1430	1425	1420	1405	1385	1365	1335	1295	1245	1190
45	1380	1380	1380	1375	1370	1360	1340	1320	1290	1255	1210	1155	1085
40	1325	1325	1320	1315	1305	1290	1270	1245	1215	1170	1120	1055	970
35	1265	1265	1260	1250	1240	1220	1200	1170	1130	1080	1020	940	840
30	1205	1205	1195	1185	1170	1150	1120	1085	1040	980	905	810	685
25	1145	1140	1130	1115	1100	1075	1040	995	940	870	780	660	485
20	1080	1070	1060	1045	1020	990	950	900	835	750	635	465	
15	1015	1005	990	970	940	905	860	795	715	605	445		
10	945	935	915	890	860	815							
5	875	860	840	810	770	720	755	680	580	425			
0	805	785	760	725	675	610	645	550	405				
-5	735	710	680	635	575	490	520	380					
-10	660	635	595	540	460	340	360						

**Table 6: HFI 070 - R717, evaporating capacity [kW]**

Condens- ing temp. (°C)	Evaporating temperature (°C)												
	-40	-35	-30	-25	-20	-15	-10	-5	0	5	10	15	20
50								2775	2725	2665	2590	2495	2375
45							2680	2640	2580	2510	2420	2310	2170
40						2445	2545	2490	2425	2340	2235	2105	1940
35							2400	2335	2260	2160	2035	1880	1680
30					2340	2300	2245	2170	2080	1960	1815	1625	1370
25				2090	2195	2145	2080	1995	1885	1745	1565	1320	965
20				1940	2040	1980	1900	1800	1670	1500	1265	930	
15					1885	1810	1715	1595	1435	1210	890		
10						1630	1515						
5		1725	1835	1785	1715	1435	1295	1365	1160	850			
0	1470	1575	1680	1620	1540	1220	1100	1100	810				
-5	1325	1425	1520	1450	1350	980	1040	765					
-10		1265	1360	1270	1150	685	725						
			1190	1080	920								

**Table 7: HFI 040 - R 717, evaporating capacity [TR]**

Condens- ing temp. (°F)	Evaporating temperature (°F)												
	-40	-30	-20	-10	0	10	20	30	40	50	60	70	80
120	134	135	135	134	134	132	131	128	125	121	116	109	101
110	129	129	129	128	127	126	123	121	117	112	106	98	87
100	123	123	122	122	120	118	116	112	108	102	94	84	71
90	117	117	116	115	113	111	107	103	98	91	81	69	50
80	110	110	109	107	105	102	99	94	87	78	66	49	
70	103	103	102	100	97	94	89	83	75	63	47		
60	97	96	94	92	89	84	79	71	60	44			
50	90	88	86	83	80	74	67	57	42				
40	82	81	78	75	70	63	54	40					
30	75	73	70	65	59	51	38						
20	67	65	61	55	47	35							
10	59	56	51	44	33								

Float valve, type HFI

Table 8: HFI 050 - R 717, evaporating capacity [TR]

Condens- ing temp. (°F)	Evaporating temperature (°F)												
	-40	-30	-20	-10	0	10	20	30	40	50	60	70	80
120	268	269	269	269	267	265	261	256	250	242	231	218	201
110	258	258	257	256	254	251	247	241	233	224	211	195	175
100	246	246	245	243	241	237	232	224	215	204	189	169	143
90	234	233	232	229	226	221	215	207	196	181	163	138	101
80	221	220	218	215	211	205	197	187	174	156	132		
70	207	206	203	200	194	187	178	166	149	127	97		
60	193	191	188	184	177	169	157	142	121	89			
50	179	176	172	167	159	149	134	114	84				
40	165	161	156	149	140	127							
30	150	145	139	130	118	102	108						
20	135	129	121	110	95	75	75	80					
10	119	112	102	88	65	70							

Table 9: HFI 060 - R 717, evaporating capacity [TR]

Condens- ing temp. (°F)	Evaporating temperature (°F)												
	-40	-30	-20	-10	0	10	20	30	40	50	60	70	80
120	403	404	404	403	401	397	392	385	375	363	347	327	302
110	386	387	386	384	381	377	370	362	350	335	317	293	262
100	369	368	367	365	361	355	347	337	323	305	283	253	214
90	350	350	348	344	339	332	322	310	293	272	244	207	151
80	331	329	327	322	316	307	296	281	261	234	199	146	
70	310	309	305	299	292	281	267	249	224	190	140		
60	290	287	282	275	266	253	236	213	181	133			
50	269	265	259	250	239	223	202	172	126				
40	247	242	234	224	209	190							
30	225	218	209	196	178	152	162						
20	202	194	182	165	142	106	113	120					
10	178	168	153	132	98								

Table 10: HFI 070 - R717, evaporating capacity [TR]

Condens- ing temp. (°F)	Evaporating temperature (°F)												
	-40	-30	-20	-10	0	10	20	30	40	50	60	70	80
120							784	769	750	725	694	654	603
110					678	710	741	723	700	671	633	586	524
100						664	695	673	646	611	566	507	428
90							645	620	587	544	489	413	302
80					632	615	592	561	521	469	397		
70				599	583	562	534	497	447	380	292		
60			517	551	532	506	472	426	362	279			
50				500	477	446	403	343	253				
40		483	469	448	419	380							
30	404	436	418	391	355	305	325						
20	357	387	364	331	284	211	226	240					
10		336	307	263	195								

## High pressure control in refrigeration system with condenser/evaporator

Figure 5: A water chiller with plate heat exchanger as both condenser and evaporator. HFI is flanged directly on to the condenser.

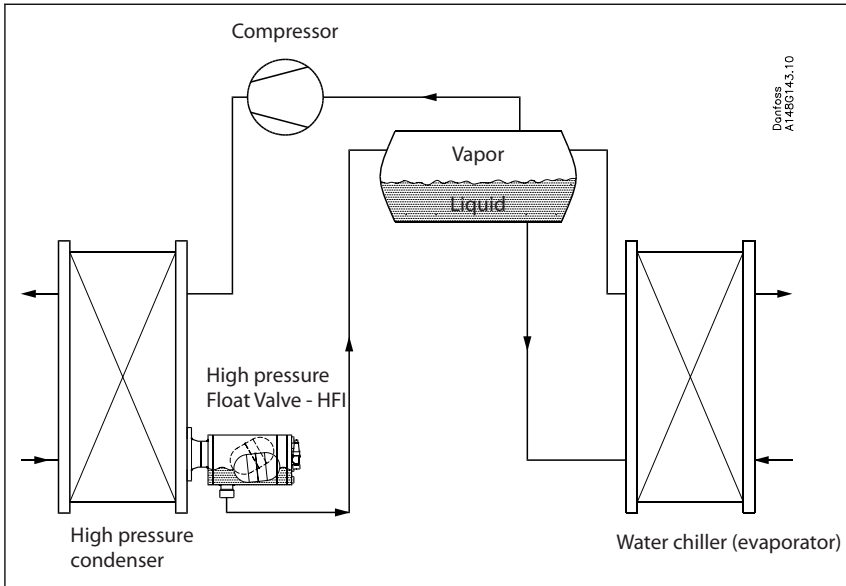

## Material specification

Figure 6: Housing parts

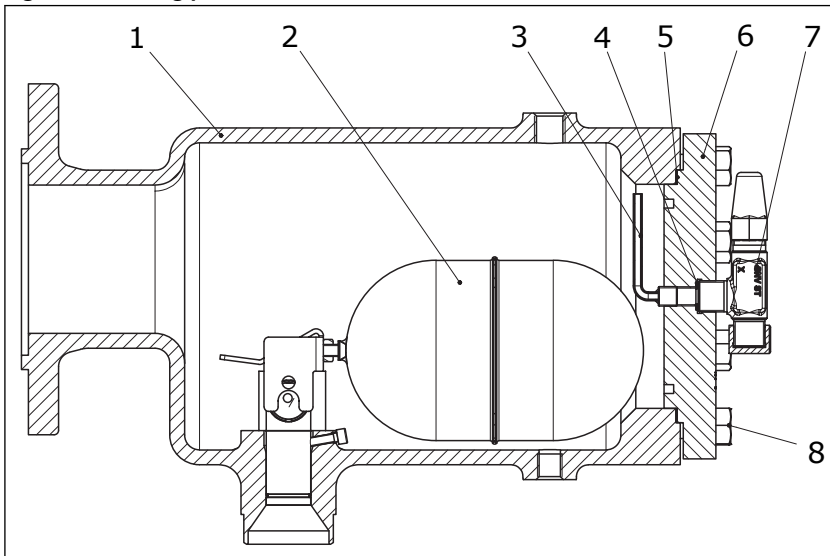

Table 11: Material specification

No	Part	Material	DIN/EN	ASTM
1	Housing	Steel	G20Mn5+QT EN10213-3	
2	Float Ball	Steel		
3	Tube	Steel		
4	Gasket	Aluminium		
5	Gasket	Non asbestos		
6	End cover with cylinder	Steel	PE275 NL1 EN 10028-3	
7	Purge valve, SNV-ST <sup>(1)</sup>			
8	Set screw	Stainless steel	A2-70	

<sup>(1)</sup> SNV-ST G½-G½ (148B3745).



## Connections

Available connections

### Flange:

Inlet: Flange DN 100 or DN 150 (DIN-2635/DIN 2512-F)

Outlet: Welding connection DN 50 (EN 10220)

### Butt-weld, DIN:

Inlet: DN 100 or DN 150 (EN 10220)

Outlet: Welding connection DN 50 (EN 10220)

### Butt-weld, ANSI:

Inlet: DN 100 (4 in.) or DN 150 (6 in.) (ANSI B 36.10)

Outlet: Welding connection DN 50 (2 in.) (ANSI 36.10)

Figure 7: DIN - Outlet

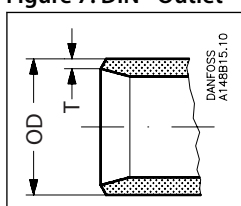

Table 12: Butt-weld DIN (EN 10220)

HFI size mm	HFI size in.	Outlet				For use with valve type
		OD mm	T mm	OD in.	T in.	
100	4	60.3	2.9	2.37	0.11	HFI 040 HFI 050 HFI 060 HFI 070
150	6	60.3	2.9	2.37	0.11	HFI 050 HFI 060 HFI 070

Figure 8: ANSI - Outlet

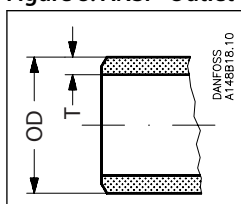
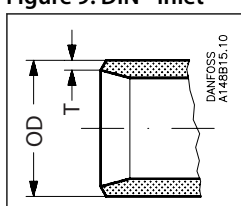

Table 13: Butt-weld ANSI (B 36.10 Schedule 40)

HFI size mm	HFI size in.	Outlet				For use with valve type
		OD mm	T mm	OD in.	T in.	
100	4	60.3	3.9	2.37	0.15	HFI 040 HFI 050 HFI 060 HFI 070
150	6	60.3	3.9	2.37	0.15	HFI 050 HFI 060 HFI 070

Figure 9: DIN - Inlet



## Float valve, type HFI

**Table 14: Butt-weld DIN (EN 10220)**

HFI size mm	HFI size in.	Inlet				For use with valve type
		OD mm	T mm	OD in.	T in.	
100	4	114.3	3.6	4.50	0.14	HFI 040 HFI 050 HFI 060 HFI 070
150	6	168.3	4.5	6.63	0.18	HFI 050 HFI 060 HFI 070

**Figure 10: ANSI - Inlet**

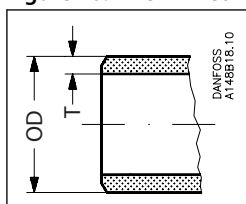

**Table 15: Butt-weld ANSI (B 36.10 Schedule 40)**

HFI size mm	HFI size in.	Inlet				For use with valve type
		OD mm	T mm	OD in.	T in.	
100	4	114.3	6.3	4.50	0.25	HFI 040 HFI 050 HFI 060 HFI 070
150	6	168.3	7.1	6.63	0.28	HFI 050 HFI 060 HFI 070

**Figure 11: Inlet flange**

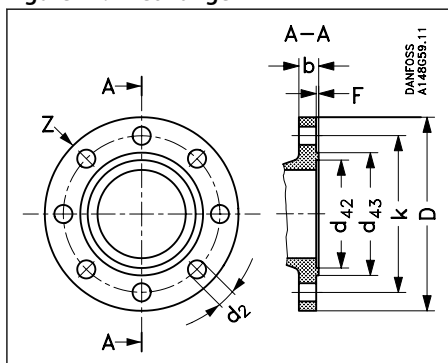

**Table 16: 40 bar / DIN 2635 / DIN 2512-F\***

		øD	b	øk	ød <sub>42</sub>	ød <sub>43</sub>	F	ød <sub>2</sub>	Z
Size 100 (4 in.)	mm	235	24	190	129	149	4.5	22	8 pcs.
	in.	9.3	0.94	7.48	5.08	5.87	0.18	0.97	
Size 150 (6 in.)	mm	300	28	250	183	203	4.5	26	8 pcs.
	in.	11.8	1.10	9.84	7.20	7.99	0.18	1.02	

\*Inlet flange and DIN outlet

## Dimensions and weights

Figure 12: High pressure float valve without flange

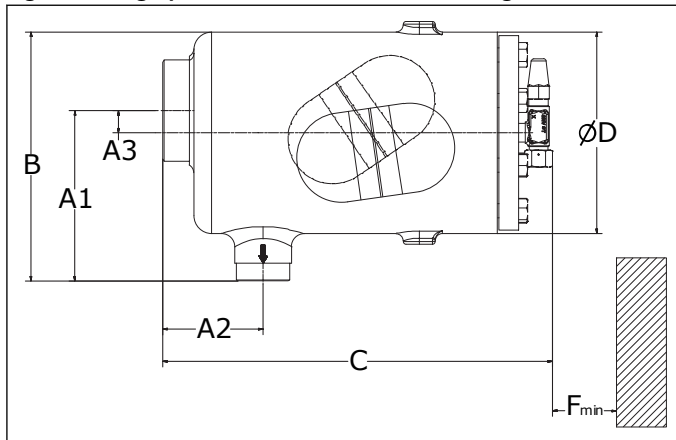

Table 17: High pressure float valve without flange

Valve size		A1	A2	A3	B	C	ØD	F <sub>min</sub>	Weight
HFI 100	mm	192	113	25	280.5	440	227	200	43 kg
	in.	7.56	4.45	0.98	11.05	17.32	8.94	7.87	94.8 lb
HFI 150	mm	167	113		280.5	440	227	200	43 kg
	in.	6.57	4.45		11.05	17.32	8.94	7.87	94.8 lb

**NOTE:**

Specified weights are approximate values only.

Figure 13: High pressure float valve with flange

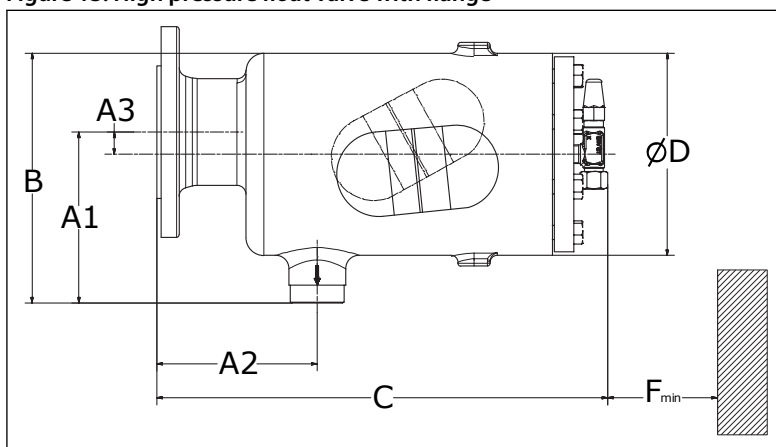

Table 18: High pressure float valve with flange

Valve size		A1	A2	A3	B	C	ØD	F <sub>min</sub>	Weight
HFI 100	mm	192	180	25	280.5	506	227	200	49 kg
	in.	7.56	7.09	0.98	11.05	19.92	8.94	7.87	108 lb
HFI 150	mm	167	189		280.5	506	227	200	49 kg
	in.	6.57	7.44		11.05	19.92	8.94	7.87	108 lb

**NOTE:**

Specified weights are approximate values only.

### Dimensions and weights (HFI with external connections)

Figure 14: High pressure float valve without flange

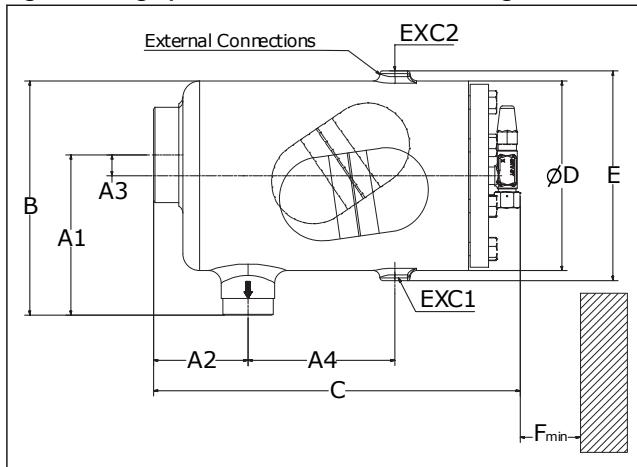

EXC1 3/8 - 18 NPT

EXC2 1/2 - 14 NPT

Table 19: High pressure float valve without flange

Valve size		A1	A2	A3	A4	B	C	ΦD	E	F <sub>min</sub>	Weight
HFI 100	mm	192	113	25	176	280.5	440	227	247	200	43 kg
	in.	7.56	4.45	0.98	6.93	11.05	17.32	8.94	9.72	7.87	94.8 lb
HFI 150	mm	167	113		176	280.5	440	227	247	200	43 kg
	in.	6.57	4.45		6.93	11.05	17.32	8.94	9.72	7.87	94.8 lb

**NOTE:**

Specified weights are approximate values only.

Figure 15: High pressure float valve with flange

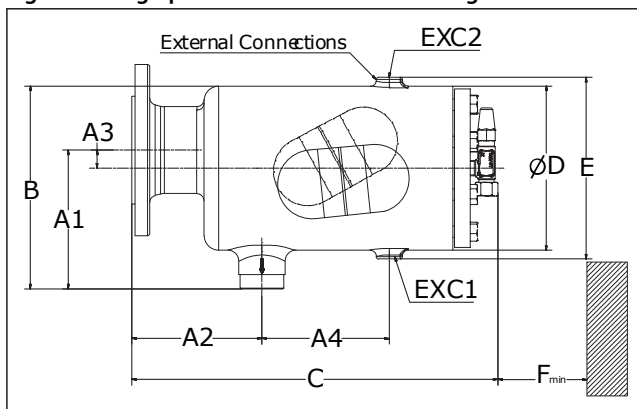

EXC1 3/8 - 18 NPT

EXC2 1/2 - 14 NPT

Table 20: High pressure float valve with flange

Valve size		A1	A2	A3	A4	B	C	ΦD	E	F <sub>min</sub>	Weight
HFI 100	mm	192	180	25	176	280.5	506	227	251	200	49 kg
	in.	7.56	7.09	0.98	6.93	11.05	19.92	8.94	9.88	7.87	108 lb
HFI 150	mm	167	180		176	280.5	506	227	247	200	49 kg
	in.	6.57	7.09		6.93	11.05	19.92	8.94	9.72	7.87	108 lb

**NOTE:**

Specified weights are approximate values only.

## Volumes

Figure 16: Min. and Max. volumes

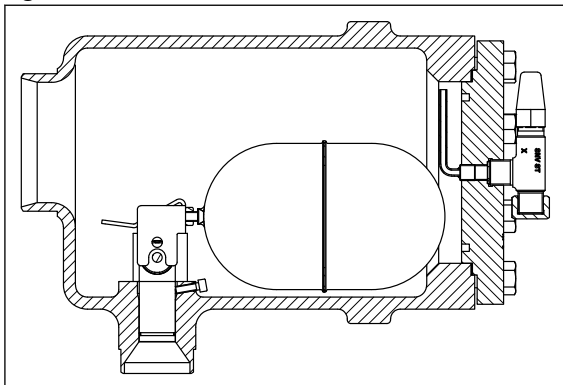

Internal volume (gross):	$11.4 \times 10^{-3} \text{ m}^3$ (3.01 US <sub>gal</sub> )
Internal volume with float ball:	$9.6 \times 10^{-3} \text{ m}^3$ (2.54 US <sub>gal</sub> )
Liquid volume at max. level:	$6.3 \times 10^{-3} \text{ m}^3$ (1.66 US <sub>gal</sub> )
Liquid volume at min. level:	$3.6 \times 10^{-3} \text{ m}^3$ (0.95 US <sub>gal</sub> )

## Ordering

The table below is used to identify the valve required.

Example: HFI 040 D 100 = 148G3092

**Table 21: Type of inlet connection size and nozzle size**

Type	Inlet connection size	Nozzle size	Code numbers
HFI 040 FD 100	100 (4 in.) DIN Flange	40	148G3102
HFI 050 FD 100		50	148G3103
HFI 060 FD 100		60	148G3104
HFI 070 FD 100		70	148G3422
HFI 050 FD 150	150 (6 in.) DIN Flange	50	148G3105
HFI 060 FD 150		60	148G3106
HFI 070 FD 150		70	148G3423
HFI 040 D 100	100 (4 in.) DIN BW	40	148G3092
HFI 050 D 100		50	148G3093
HFI 060 D 100		60	148G3094
HFI 070 D 100		70	148G3418
HFI 050 D 150	150 (6 in.) DIN BW	50	148G3095
HFI 060 D 150		60	148G3096
HFI 070 D 150		70	148G3419
HFI 040 A 100	100 (4 in.) ANSI BW	40	148G3097
HFI 050 A 100		50	148G3098
HFI 060 A 100		60	148G3099
HFI 070 A 100		70	148G3420
HFI 050 A 150	150 (6 in.) ANSI BW	50	148G3100
HFI 060 A 150		60	148G3101
HFI 070 A 150		70	148G3421

**Table 22: HFI with 2 external connections**

Type	Inlet connection size	Nozzle size	Code numbers
HFI 040 FD 100 w. 2 ext. con	100 (4 in.) DIN Flange	40	148G3196
HFI 050 FD 100 w. 2 ext. con		50	148G3727
HFI 060 FD 100 w. 2 ext. con		60	148G3670
HFI 070 FD 100 w. 2 ext. con		70	148G3671
HFI 050 FD 150 w. 2 ext. con	150 (6 in.) DIN Flange	50	148G3762
HFI 060 FD 150 w. 2 ext. con		60	148G3763
HFI 070 FD 150 w. 2 ext. con		70	148G3764
HFI 040 D 100 w. 2 ext. con	100 (4 in.) DIN BW	40	148G3765
HFI 050 D 100 w. 2 ext. con		50	148G3704
HFI 060 D 100 w. 2 ext. con		60	148G3766
HFI 070 D 100 w. 2 ext. con		70	148G3720
HFI 050 D 150 w. 2 ext. con	150 (6 in.) DIN BW	50	148G3767
HFI 060 D 150 w. 2 ext. con		60	148G3768
HFI 070 D 150 w. 2 ext. con		70	148G3769

**FD** = inlet flange DIN  
**D** = Butt welding DIN  
**A** = Butt welding ANSI

**Table 23: Connection types**

Type	Code numbers
Insert for HFI 070 (complete insert with float ball - without float housing)	148G3584
Insert for HFI 060 (complete insert with float ball - without float housing)	148G3663
Insert for HFI 050 (complete insert with float ball - without float housing)	148G3662
Insert for HFI 040 (complete insert with float ball - without float housing)	148G3661

## Accessories

Figure 17: Connection types

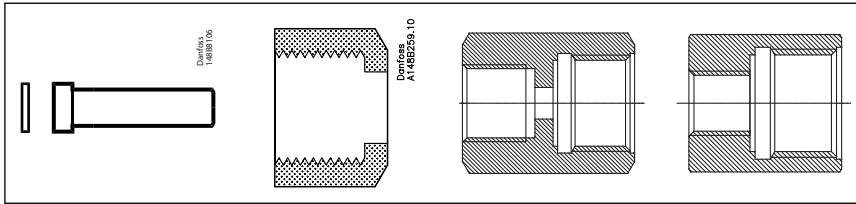

Table 24: Connection types

Type	Connection type	Quantity	Code no.
Welding nipple incl. aluminium gasket	G $\frac{1}{2}$ -ND6	2 pcs.	14884184
Al gaskets included	$\frac{1}{4}$ " FPT - $\frac{1}{2}$ " G	1 pc.	14883860
Al gaskets included	$\frac{3}{8}$ " G - $\frac{1}{2}$ " G	1 pc.	14883861

## Certificates, declarations, and approvals

The list contains all certificates, declarations, and approvals for this product type. Individual code number may have some or all of these approvals, and certain local approvals may not appear on the list.

Some approvals may change over time. You can check the most current status at danfoss.com or contact your local Danfoss representative if you have any questions.

**Table 25: Pressure Equipment Directive (PED)**

	The HFI-valves are approved in accordance with the European standard specified in the Pressure Equipment Directive and are CE marked.
---	---

For further details / restrictions - see Installation Instruction

**Table 26: Valves specifications**

HFI valves	
Nominal bore	DN 100 and 150 mm (4 in. and 6 in.)
Classified for	Fluid group I
Catagory	III

**Table 27: Certificates and declarations**

File name	Document type	Document topic	Approval authority
RU Д-ДК.БЛ08.В.00191_18	EAC Declaration	Machinery & Equipment	EAC
03709-F0 BV	Marine - Safety Certificate	-	BV
RU Д-ДК.РА01.В.72054_20	EAC Declaration	PED	EAC
RU С-ДК.БЛ08.В.01093_20	Pressure - Safety Certificate	PED	EAC
033F0685.AK	EU Declaration	EMCD/PED	Danfoss
033F0691.AE	Manufacturers Declaration	RoHS	Danfoss
0045 202 1204 Z 00355 19 D 001(00)	Pressure - Safety Certificate	-	TÜV
033F0473.AD	Manufacturers Declaration	ATEX	Danfoss
19.10327.266	Marine - Safety Certificate	-	RMRS



## Online support

Danfoss offers a wide range of support along with our products, including digital product information, software, mobile apps, and expert guidance. See the possibilities below.

### The Danfoss Product Store



The Danfoss Product Store is your one-stop shop for everything product related—no matter where you are in the world or what area of the cooling industry you work in. Get quick access to essential information like product specs, code numbers, technical documentation, certifications, accessories, and more.

Start browsing at [store.danfoss.com](https://store.danfoss.com).

### Find technical documentation



Find the technical documentation you need to get your project up and running. Get direct access to our official collection of data sheets, certificates and declarations, manuals and guides, 3D models and drawings, case stories, brochures, and much more.

Start searching now at [www.danfoss.com/en/service-and-support/documentation](https://www.danfoss.com/en/service-and-support/documentation).

### Danfoss Learning



Danfoss Learning is a free online learning platform. It features courses and materials specifically designed to help engineers, installers, service technicians, and wholesalers better understand the products, applications, industry topics, and trends that will help you do your job better.

Create your Danfoss Learning account for free at [www.danfoss.com/en/service-and-support/learning](https://www.danfoss.com/en/service-and-support/learning).

### Get local information and support



Local Danfoss websites are the main sources for help and information about our company and products. Find product availability, get the latest regional news, or connect with a nearby expert—all in your own language.

Find your local Danfoss website here: [www.danfoss.com/en/choose-region](https://www.danfoss.com/en/choose-region).

### Spare Parts



Get access to the Danfoss spare parts and service kit catalog right from your smartphone. The app contains a wide range of components for air conditioning and refrigeration applications, such as valves, strainers, pressure switches, and sensors.

Download the Spare Parts app for free at [www.danfoss.com/en/service-and-support/downloads](https://www.danfoss.com/en/service-and-support/downloads).

### Coolselector®2 - find the best components for you HVAC/R system



Coolselector®2 makes it easy for engineers, consultants, and designers to find and order the best components for refrigeration and air conditioning systems. Run calculations based on your operating conditions and then choose the best setup for your system design.

Download Coolselector®2 for free at [coolselector.danfoss.com](https://coolselector.danfoss.com).

### Danfoss A/S

Climate Solutions • [danfoss.com](https://danfoss.com) • +45 7488 2222

Any information, including, but not limited to information on selection of product, its application or use, product design, weight, dimensions, capacity or any other technical data in product manuals, catalogues descriptions, advertisements, etc. and whether made available in writing, orally, electronically, online or via download, shall be considered informative, and is only binding if and to the extent, explicit reference is made in a quotation or order confirmation. Danfoss cannot accept any responsibility for possible errors in catalogues, brochures, videos and other material. Danfoss reserves the right to alter its products without notice. This also applies to products ordered but not delivered provided that such alterations can be made without changes to form, fit or function of the product.

All trademarks in this material are property of Danfoss A/S or Danfoss group companies. Danfoss and the Danfoss logo are trademarks of Danfoss A/S. All rights reserved.