

HWSG

Water cooled heat pump reversible water side

Cooling capacity 110 ÷ 396 kW
Heating capacity 122 ÷ 595 kW

- Use of the new ecological gas R1234ze
- Unit optimised for high condenser temperatures.
- Production of hot water from condenser up to 65° C.

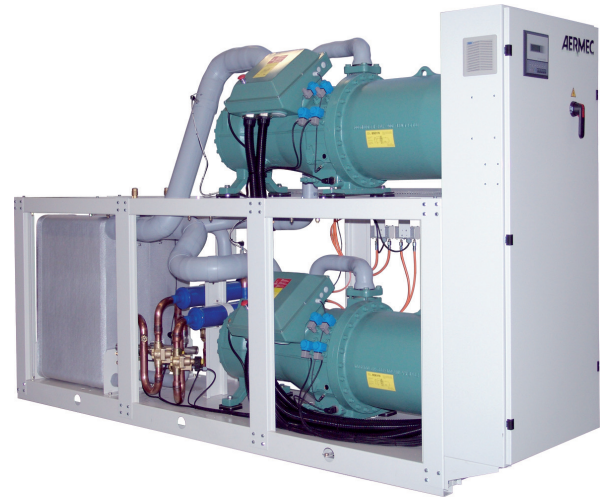

DESCRIPTION

Units for internal installation offering chilled/hot water, designed to mit air conditioning needs in residential/commercial complexes or industrial applications.

Compact and flexible, perfect alignment to the requested load thanks to an accurate control algorithm.

The base, the structure and the panels are made of galvanized steel treated with polyester paint RAL 9003.

VERSIONS

° Standard

L Standard silenced

FEATURES

Operating field

Production of chilled water up to 4°C of water produced on the evaporator side, but also suitable for use in heat pump mode with condenser water temperature up to 65°C.

Units mono or dual-circuit

Depending on the size, the units are one-circuit or two-circuit models to ensure maximum efficiency with full loads as well as partial loads and guarantee operation continuity if one of the circuits stop.

They are equipped with screw compressors and system and source side plate heat exchangers dedicated to use of the new HFO R1234ze gas.

HFO R1234ze refrigerant gas

HFO R1234ze is a mixture featuring:

ODP = 0 e GWP (Global Warming Potential) = 7, R134a GWP = 1430, with thermodynamic properties that guarantee and sometimes improve efficiencies achieved with HFC refrigerants.

Electronic expansion valve

The possibility to use electronic expansion valve, offers significant benefits, especially when the chiller is working with partial loads, increasing the energy efficiency of the unit. Standard for all sizes.

CONTROL

pCO⁵ control type

Microprocessor adjustment, with keyboard and LCD display, for easy access on the unit is a menu available in several languages.

Adjustment includes complete management of the alarms and their log.

Possibility to control two units in a Master-Slave configuration

The presence of a programmable timer allows functioning time periods and a possible second set-point to be set.

The temperature control takes place with the integral proportional logic, based on the water output temperature.

ACCESSORIES

AER485P1: RS-485 interface for supervision systems with MODBUS protocol.

AER485P1 x n° 2: RS-485 interface for supervision systems with MODBUS protocol.

AERBACP: Ethernet communication Interface for protocols Bacnet/IP, Modbus TCP/IP, SNMP

AERNET: The device allows the control, the management and the remote monitoring of a Chiller with a PC, smartphone or tablet using Cloud connection. AERNET works as Master while every unit connected is configured as Slave (max. 6 unit); also, with a simple click is possible to save a log file with all the connected unit datas in the personal terminal for post analysis.

MULTICHILLER_EVO: Control, switch-on and switch-off system of the single chillers where multiple units are installed in parallel, always ensuring constant flow rate to the evaporators.

PRV3: Allows you to control the chiller at a distance.

AVX: Spring anti-vibration supports.

ACCESSORIES COMPATIBILITY

Model	Ver	0601	0701	0801	0901	1101	1202	1402	1602	1802	2002	2202	2502	2802
AER485P1	°L	*	*	*	*	*								
AER485P1 x n° 2 (1)	°L						*	*	*	*	*	*	*	*
AERBACP	°L	*	*	*	*	*	*	*	*	*	*	*	*	*
AERNET	°L	*	*	*	*	*	*	*	*	*	*	*	*	*
MULTICHILLER_EVO	°L	*	*	*	*	*	*	*	*	*	*	*	*	*
PRV3	°L	*	*	*	*	*	*	*	*	*	*	*	*	*

(1) x Indicates the quantity of accessories to match.

Antivibration

Ver	0601	0701	0801	0901	1101	1202	1402	1602	1802	2002	2202	2502	2802
°L	AVX651	AVX651	AVX652	AVX652	AVX656	AVX658	AVX658	AVX658	AVX659	AVX667	AVX661	AVX661	AVX661

CONFIGURATOR

Field	Description
1,2,3,4	HWSG
5,6,7,8	Size 0601, 0701, 0801, 0901, 1101, 1202, 1402, 1602, 1802, 2002, 2202, 2502, 2802
9	Operating field
X	Electronic thermostatic expansion valve (1)
Z	Low temperature electronic thermostatic valve (2)
10	Model
°	Optimised for high condenser temperatures
11	Heat recovery
°	Without heat recovery
D	With desuperheater (3)
T	With total recovery (3)
12	Version
°	Standard
L	Standard silenced
13	Evaporator
°	Standard
14	Power supply
°	400V ~ 3 50Hz with fuses

(1) Water produced from 4 °C ÷ 16 °C

(2) Water produced from -5 °C ÷ 4 °C

(3) Order management

PERFORMANCE SPECIFICATIONS

HWSG - °/L

Size			0601	0701	0801	0901	1101	1202	1402	1602	1802	2002
Cooling performance 12 °C / 7 °C (1)												
Cooling capacity	°L	kW	110,5	135,1	156,5	176,0	215,8	221,7	271,4	315,9	354,9	396,8
Input power	°L	kW	23,2	27,7	31,3	35,6	43,2	46,2	57,0	63,9	73,6	80,7
Cooling total input current	°L	A	48,0	55,0	61,0	66,0	82,0	96,0	111,0	122,0	132,0	149,0
EER	°L	W/W	4,77	4,87	5,00	4,94	4,99	4,80	4,76	4,94	4,82	4,92
Water flow rate system side	°L	l/h	19007	23236	26907	30255	37102	38143	46690	54329	61030	68240
Pressure drop system side	°L	kPa	16	11	10	11	12	24	32	21	23	25
Water flow rate source side	°L	l/h	22875	27903	32183	36261	44378	45808	56089	64986	73289	81668
Pressure drop source side	°L	kPa	23	16	15	15	17	34	47	31	34	36
Heating performance 40 °C / 45 °C (2)												
Heating capacity	°L	kW	122,8	149,7	172,4	194,4	237,8	245,8	301,0	348,2	393,1	437,6
Input power	°L	kW	27,7	33,1	37,3	42,5	51,6	55,2	68,3	76,4	88,0	96,5
Heating total input current	°L	A	58,0	65,0	72,0	78,0	97,0	114,0	131,0	145,0	157,0	176,0
COP	°L	W/W	4,43	4,52	4,62	4,57	4,61	4,45	4,41	4,56	4,47	4,53
Water flow rate system side	°L	l/h	21319	25989	29942	33756	41288	42668	52248	60463	68263	75995
Pressure drop system side	°L	kPa	20	14	13	13	15	29	41	27	30	31
Water flow rate source side	°L	l/h	27820	34012	39384	44285	54307	55832	68342	79522	89331	99885
Pressure drop source side	°L	kPa	35	24	22	23	26	50	69	46	50	54

(1) Date 14511:2018; Water user side 12 °C / 7 °C; Water source side 30 °C / 35 °C

(2) Date 14511:2018; Water user side 40 °C / 45 °C; Water source side 10 °C / 7 °C

Size				2202	2502	2802
Heating performance 40 °C / 45 °C (1)						
Heating capacity	°L	kW		488,6	540,8	595,5
Input power	°L	kW		106,1	119,3	131,9
Heating total input current	°L	A		196,0	225,0	240,0
COP	°L	W/W		4,60	4,53	4,52
Water flow rate system side	°L	l/h		84852	93902	103410
Pressure drop system side	°L	kPa		34	37	45
Water flow rate source side	°L	l/h		112042	123541	136133
Pressure drop source side	°L	kPa		58	62	75

(1) Date 14511:2018; Water user side 40 °C / 45 °C; Water source side 10 °C / 7 °C

ENERGY INDICES (REG. 2016/2281 EU)

Size			0601	0701	0801	0901	1101	1202	1402	1602	1802	2002
SEER - 12/7 (EN14825: 2018) (1)												
Seasonal efficiency	°L	%	205,9%	214,4%	222,6%	221,7%	221,9%	210,8%	211,5%	228,3%	223,0%	226,4%
SEER	°L	W/W	5,22	5,44	5,64	5,62	5,62	5,35	5,36	5,78	5,65	5,74
UE 813/2013 performance in average ambient conditions (average) - 55 °C - Pdesignh ≤ 400 kW (2)												
Pdesignh	°L	kW	155	188	217	245	299	309	379	-	-	-
SCOP	°L		4,52	4,62	4,72	4,69	4,69	4,63	4,60	-	-	-
nsh	°L	%	173,0%	177,0%	181,0%	179,0%	181,0%	177,0%	176,0%	-	-	-

(1) Calculation performed with VARIABLE water flow rate and VARIABLE outlet temperature.

(2) Efficiencies for average temperature applications (55 °C)

ELECTRIC DATA

Size			0601	0701	0801	0901	1101	1202	1402	1602	1802	2002	2202	2502	2802
Electric data															
Maximum current (FLA)	°L	A	75,6	95,6	104,4	115,9	143,2	151,2	191,2	208,8	231,8	259,1	286,4	323,8	352,0
Peak current (LRA)	°L	A	180,0	163,0	192,0	229,0	267,0	255,6	258,6	296,4	344,9	372,2	410,2	475,9	490,0

GENERAL TECHNICAL DATA

Size			0601	0701	0801	0901	1101	1202	1402	1602	1802	2002	2202	2502	2802
Compressor															
Type	°L	type	Screw												
Compressor regulation	°L	Type	On/Off												
Number	°L	no.	1	1	1	1	1	2	2	2	2	2	2	2	2
Circuits	°L	no.	1	1	1	1	1	2	2	2	2	2	2	2	2
Refrigerant	°L	type	R1234ze												
Refrigerant load circuit 1 (1)	°L	kg	18,0	20,0	22,0	25,0	38,0	18,0	20,5	21,5	25,0	25,0	33,0	35,0	39,0
Refrigerant load circuit 2 (1)	°L	kg	-	-	-	-	-	18,0	20,0	22,0	25,0	30,0	18,0	20,5	21,5
System side heat exchanger															
Type	°L	type	Braze plate												
Number	°L	no.	1	1	1	1	1	1	1	1	1	1	1	1	1
Source side heat exchanger															
Type	°L	type	Braze plate												
Number	°L	no.	1	1	1	1	1	1	1	1	1	1	1	1	1
System side hydraulic connections															
Connections (in/out)	°L	Type	Grooved joints												
Size (in) (2)	°L	Ø	3"												
Size (out) (2)	°L	Ø	3"												
Source side hydraulic connections															
Connections (in/out)	°L	Type	Grooved joints												
Size (in)	°L	Ø	3"												
Size (out)	°L	Ø	3"												
Sound data calculated in cooling mode (3)															
Sound power level	°	dB(A)	87,0	86,0	86,0	86,0	92,0	89,0	90,0	89,0	89,0	93,0	95,0	95,0	95,0
	L	dB(A)	78,9	78,0	78,0	78,0	84,0	81,0	81,9	81,0	81,0	85,0	87,0	87,0	87,0
Sound pressure level (10 m)	°	dB(A)	55,2	54,2	54,2	54,2	60,2	57,2	58,1	57,2	57,2	61,1	63,1	63,1	63,1
	L	dB(A)	47,1	46,2	46,2	46,2	52,2	49,1	50,0	49,1	49,1	53,1	55,1	55,1	55,1

(1) The load indicated in the table is an estimated and preliminary value. The final value of the refrigerant load is indicated on the unit's technical label. For further information contact the office.

(2) Size

(3) Sound power calculated on the basis of measurements made in accordance with UNI EN ISO 9614-2, as required for Eurovent certification. Sound pressure (cold functioning) measured in free field, 10m away from the unit external surface (in compliance with UNI EN ISO 3744).

DIMENSIONS

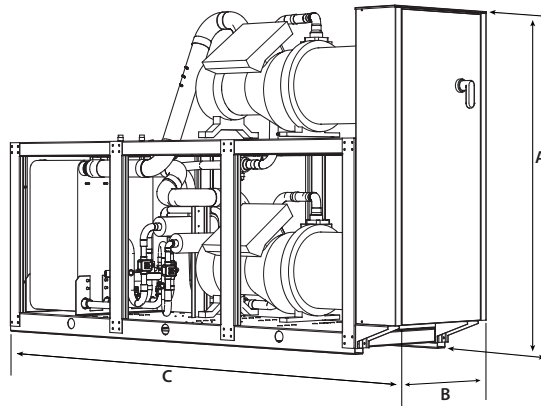

Size			0601	0701	0801	0901	1101	1202	1402	1602	1802	2002	2202	2502	2802
Dimensions and weights															
A	°	mm	1775	1775	1775	1775	1775	1975	1975	1975	2005	1985	2065	2065	2065
	L	mm	1775	1775	1775	1775	1775	2120	2120	2120	2120	2120	2120	2120	2120
B	°L	mm	810	810	810	810	810	810	810	810	810	810	810	810	810
C	°L	mm	2960	2960	2960	2960	3360	2960	2960	2960	2960	3360	3360	3360	3360
Empty weight	°	kg	1101	1251	1301	1357	1788	1738	2028	2097	2169	2598	3000	3095	3095
	L	kg	1229	1379	1429	1485	1934	1966	2256	2325	2397	2855	3257	3352	3352

Aermec reserves the right to make any modifications deemed necessary. All data is subject to change without notice. Aermec does not assume responsibility or liability for errors or omissions.

Aermec S.p.A.

Via Roma, 996 - 37040 Bevilacqua (VR) - Italia
Tel. 0442633111 - Telefax 044293577
www.aermec.com