

Installation Guide

Safety relief valves

BSV 8

UK
DK

148R9506

Installation
安装方向

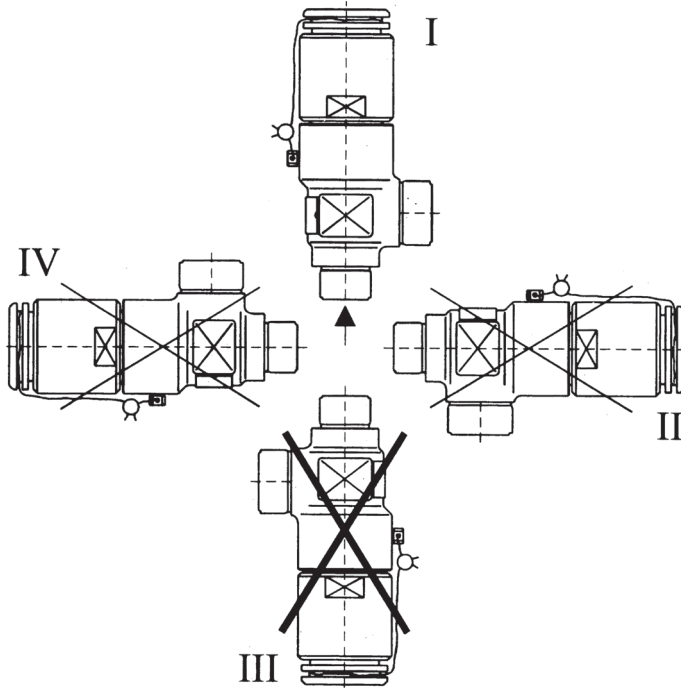

1

2

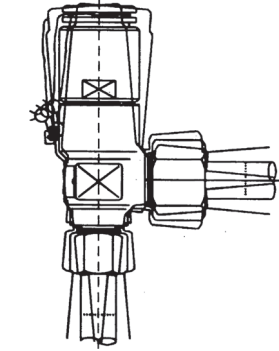

3

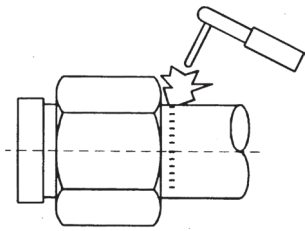

BSV mounted as safety valve:
with fitting 148F3019

BSV作为安全阀安装:
配合部件 148 F 3019

BSV mounted as pilot valve for POV:
with fitting 2469+069

BSV作为POV导阀安装:
配合部件 2469+069

↑
Upwards
朝上

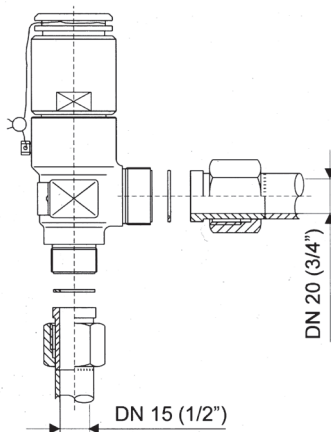

↑
Upwards
朝上

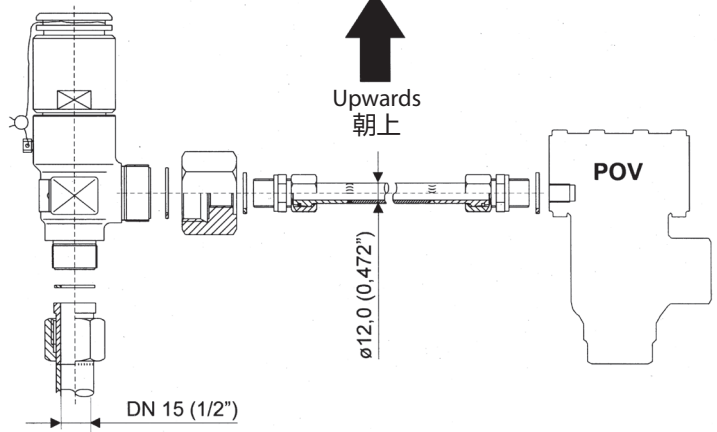

4

148R9506

Info for UK customers only: Danfoss Ltd. Oxford Road, UB9 4LH Denham, UK

ENGLISH

Installation

Refrigerants

Applicable to all common non-flammable refrigerants, including R717 and non-corrosive gases/liquids dependent on sealing material compatibility. Special types required for flammable hydrocarbons. The valve is only recommended for use in closed circuits. For further information please contact Danfoss.

Temperature range

Temperature range for BSV used as an external safety relief valve:
-30/+100°C (-22/+212°F)

Temperature range for BSV used as a pilot valve for POV:
-50/+100°C (-58/+212°F)

Note:

For temperatures below -30°C (-22°F), the valve may not re-seat to a 100% gas tightness when activated.

Pressure range

The valve is designed for a max. working pressure of 25 bar g (362 psi g). Danfoss Industrial Refrigeration A/S is supplying safety valves adjusted for a certain pressure (indicated on the ID-plate) and sealed.

Danfoss Industrial Refrigeration guarantees correct pressure as long as the seal remains unbroken.

Installation

The valve should be installed with the spring housing upwards (fig. 1). By mounting of the safety valve it is important to avoid the influence of thermic and dynamic stress (vibrations) (fig. 2). The valve is designed to withstand a high internal pressure. However, the piping system should be designed to avoid liquid traps and reduce the risk of hydraulic pressure caused by thermal expansion. It must be ensured that the valve is protected from pressure transients like "liquid hammer" in the system.

Welding

If welding fittings are applied, these should be dismantled during the welding process (fig. 3). Only materials and welding methods, compatible with the flange material, must be welded to the flange. Avoid welding debris and dirt in the threads of the housing and pipes.

Assembly

Remove welding slag and dirt from tubes and housing before the valve is mounted. Mount the valve as shown in fig. 4.

Colours and identification

The valves are Zinc-Chromated in the factory. If further corrosion protection is required, it can be painted. Precise identification of the valve is made via the ID label on the valve housing. In cases of doubt, please contact Danfoss. Danfoss accepts no responsibility for errors and omissions. Danfoss Industrial Refrigeration reserves the right to make changes to products and specifications without prior notice.

安装方向

制冷剂

适用于各种不可燃制冷剂，包括氨和其他无腐蚀性的气体\液体工质（需考虑密封介质的兼容性）。

不推荐将其应用在易燃易爆的碳氢制冷剂上。阀门应使用在密封的制冷系统内部。如需了解更多详情信息请联系丹佛斯。

温度范围

作为外部安全泄压阀使用的 BSV 的温度范围：

-30/+100°C (-22/+212°F)

作为 POV 导阀使用的 BSV 的温度范围：

-50/+100°C (-58/+212°F)

注意：

温度低于 -30°C (-22°F) 时，阀门开启后不能保证 100% 回座气密性。

压力范围

阀门最大设计工作压力为 25 bar (362 psi g)。丹佛斯工业制冷提供设定好压力的安全阀（标记在 ID 牌上）并且铅封。

只要不破坏铅封，丹佛斯即可保证正确的设定压力。

安装

为保证安全阀的正常工作，阀门的弹簧阀体必须竖直向上安装（图 1）。

安装安全阀时，避免热和动应力（振动）的影响（图 2）。

BSV 系列安全阀的设计可以承受很高的内部压力。尽管如此，管路系统的设计也必须避免有存液弯，防止系统出现因热膨胀导致的过高压力而损坏管路。管路的设计应考虑对系统中出现瞬时“液击”现象的有效防护。

焊接

焊接接头过程中，接头必须从阀门上拆下焊接（图 3）。焊接过程中，需要保证焊料和焊接方法适用于阀体或法兰的材质，选择合适的焊料和正确的焊接方法。

焊接后阀体内需要认真清理，确保安装前焊渣已清理干净，避免焊接杂质和污垢进入管道及螺纹。

装配

在组装阀之前，清除阀体和管道里的焊渣和污垢。如图 4 所示安装阀门。

颜色和识别

BSV 系列安全阀已在出厂前进行了镀锌铬防锈处理。然而此处理没有覆盖到阀门的焊接连接部分。如果需要做进一步防腐蚀保护，可以为阀门喷漆处理。阀门的精确标识位于阀体的信息识别 (ID) 标签上。

如有任何疑问，请联系丹佛斯当地办事处。丹佛斯对错误或疏漏概不负责。丹佛斯工业制冷部门保留在不预先通知的情况下变更产品和规格的权利。

