

Data sheet

# MMIGRS2

## Programmable controller



MMIGRS2 is MCX's family remote interface. It's fitted with a graphic display that allows a complete customization of the user interface. The connection with every unit of the MCX range is made through the CANbus network. All the information about the user interface is loaded inside the MCX controller; that's why there is no need of programming the MMIGRS2 interface. MMIGRS2 is powered externally or from the controller which it is connected to and automatically shows its user interface.

### Features MMIGRS2

- Full graphic LCD display, 128x64 dots resolution
- Easy connection to MCX CANbus network through telephone plug and CAN connector
- No need to be programmed: information about user interface is loaded from the MCX controller
- Powered by the MCX which it is connected to
- Dimensions 88x150 mm
- Panel and wall mounting
- IP64 protection rating on panel version

**General features**

FEATURES	DESCRIPTION
Power supply	From the MCX through the RJ11 telephone connector
	12 – 30 V DC (separate power supply is recommended)
	24 V AC +10% / -15% (separate power supply is recommended)
	Maximum power consumption: 1.5 W
Plastic housing	Self extinguishing V0 according to IEC 60695-11-10 and glowing / hot wire test at 960 °C according to IEC 60695-2-12
Ball test	125 °C according to IEC 60730-1 Leakage current: $\geq 250$ V according to IEC 60112
Operating conditions	CE: -20T60 / UL: -20T60, 90% RH non-condensing
Storage conditions	-30T80, 90% RH non-condensing
Integration	In Class I and / or II appliances
Index of protection	IP64 ~ NEMA3R (panel version)
	IP40 (wall version)
Period of electric stress across insulating parts	Long
Resistance to heat and fire	Category D
Immunity against voltage surges	Category II
Software class and structure	Class A
Approvals	CE mark This product is designed to comply with the following EU standards: <ul style="list-style-type: none"> <li>• Electromagnetic compatibility EMC directive 2014/30/EU: <ul style="list-style-type: none"> <li>– EN 61000-6-4: 2007 +A1: 2011 (Emissions standard for industrial environments)</li> <li>– EN 61000-6-2: 2005 (Immunity for industrial environments)</li> </ul> </li> <li>• RoHS directive 2011/65/EU: <ul style="list-style-type: none"> <li>– EN50581: 2012</li> </ul> </li> </ul>
	UL approval: <ul style="list-style-type: none"> <li>• UL file E31024</li> </ul>

**Connection diagram:  
MCX or MCX06 connection**

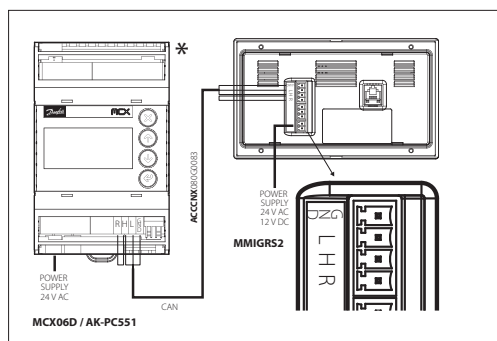

CANH-R connection should be done only on the first and last element of the network

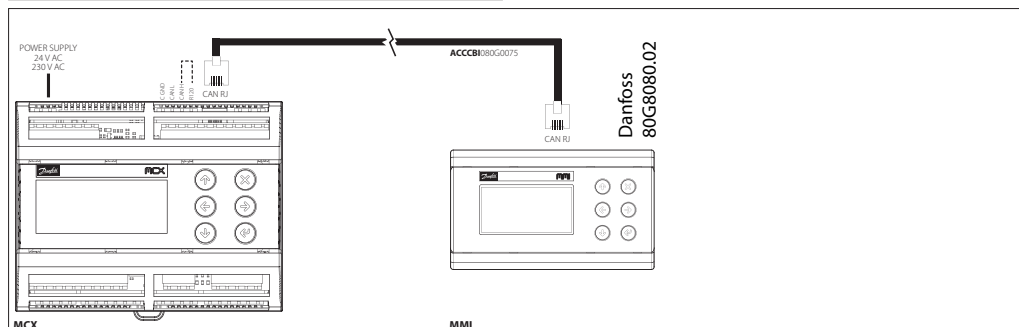

\* NOTE: when MMI is not connected to Danfoss controller via telephone cable, the autodetection feature of the MCX CAN address will not work  
Therefore check the following MMIGRS2 setting:  
1) enter BIOS menu pressing and holding X + Enter keys for 5 seconds  
2) select "MCXselection"-> "Manual Mode" and set the CAN address of the MCX06 you wish to connect to

**Connection**

CONNECTORS	TYPE	DIMENSIONS
Power supply connector	24 V AC - 2 way screw plug-in connector type	<ul style="list-style-type: none"> <li>pitch 3.5 mm</li> <li>section cable 0.08-1.5 mm<sup>2</sup></li> </ul>
CAN connector	4 way screw plug-in connector type	<ul style="list-style-type: none"> <li>pitch 3.5 mm</li> <li>section cable 0.08-1.5 mm<sup>2</sup></li> </ul>
CAN-RJ connector	6/6 way telephone RJ11 plug type	

**Dimensions  
Panel mounting**

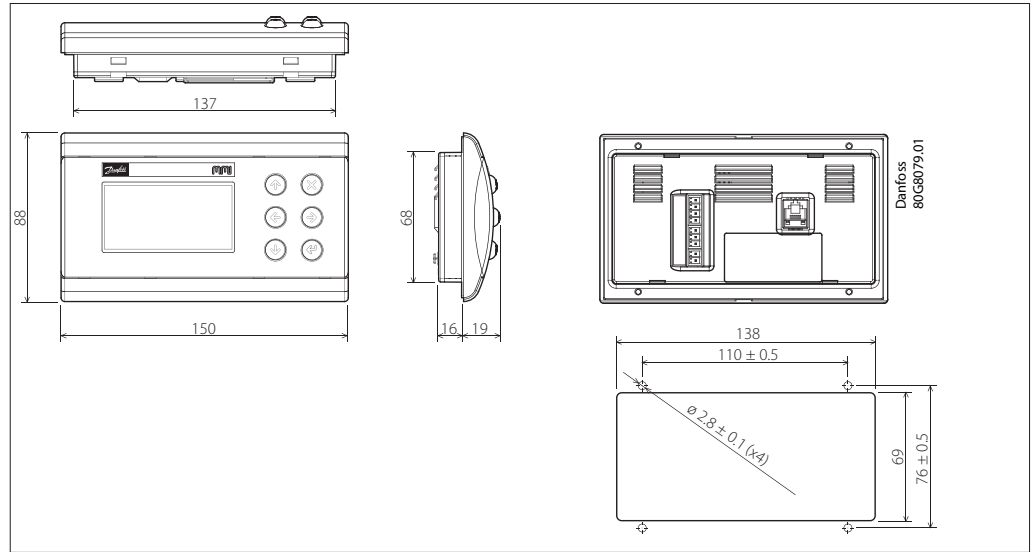

**Dimensions  
Wall mounting**

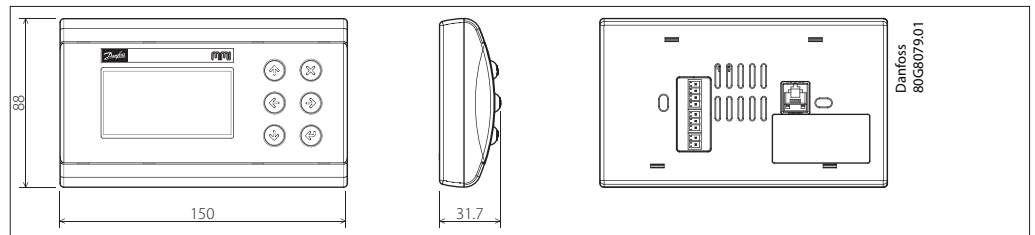

**User interface**

TYPE	FEATURES	DESCRIPTION
LCD display	Display	Graphical LCD blue transmissive
	Backlight	White LED backlight adjustable via software
	Contrast	Adjustable via software
	Format	128x64 dots
Keyboard	Number of keys	6, white LED backlight keys individually managed via software
	Keys function	Set by the application software
Mounting	Panel mounting	See the drilling template in figure, using the screws supplied in the packaging
	Wall mounting	Standard 3 modules box

**Product part numbers**

DESCRIPTION	CODE NO.
MMIGRS2, REMOTE DISPLAY, PANEL, S	080G0294
MMIGRS2, REMOTE DISPLAY, WALL, S	080G0295
MMIGRS2, REMOTE DISPLAY, PANEL, I	080G0297

Note: both single pack codes (S) and industrial pack codes (I) include standard kit connector

**Accessories part numbers**

DESCRIPTION	CODE NO.
ACCBCI, TELEPHONE CABLE USER INTERFACE CONNECTOR, 1.5m CABLE	080G0075
ACCBCI, TELEPHONE CABLE USER INTERFACE CONNECTOR, 3m CABLE	080G0076

Danfoss can accept no responsibility for possible errors in catalogues, brochures and other printed material. Danfoss reserves the right to alter its products without notice. This also applies to products already on order provided that such alterations can be made without consequential changes being necessary in specifications already agreed. All trademarks in this material are property of the respective companies. Danfoss and the Danfoss logotype are trademarks of Danfoss A/S. All rights reserved.