

Data sheet

Pressure transmitter for A/C and refrigeration

AKS 3000



AKS 3000 is a series of absolute pressure transmitters with high-level signal conditioned current output, developed to meet demands in A/C and refrigeration applications.

AKS 3000 utilizes the proved piezoresistive measuring principle, which has been used for decades in Danfoss pressure transmitters. The pressure reference is a sealed gauge. This means that atmospheric pressure variations have no influence on regulating accuracy. A must in accurate low pressure regulation.

All materials in contact with the refrigerant and materials for the housing are AISI 316L stainless steel. No soft gaskets, all environmental sealings are made through laser weldings only.

AKS 3000 has a 4 – 20 mA output, and is available with spade terminals for EN 175301-803 plug.

Features

Designed to meet A/C and refrigeration application demands without compromising control accuracy concerning:

Tough environment

- Vibration
- Shock during operation and transport
- Humidity and ice formation
- Temperature variations
- Corrosive media like ammonia gases and salt mist

Convenient performance

- 4 – 20 mA signal
- 1% typical accuracy
- 0.5% typical linearity
- Prepared for high pressure refrigerants
- Bar code for tracing of calibration data

Convenient performance

- Compact design
- Max. working pressure 33 bar <math>P < 100 \text{ bar}</math>

- Digitally temperature compensation
- Optimized accuracy at -10 °C and 20 °C for suction line installations, see page 2
- ¼ -18 NPT, G 3/8 A, G ½ A or ¼ flare ensures tight pressure connection
- All laser welded AISI 316L stainless steel enclosure
- No soft seals
- Enclosure: IP65
- For use in ATEX zone 2 explosive atmospheres

Application

- Fan speed control
- High pressure control
- Compressor capacity control
- Evaporator pressure detection
- Oil pressure control

Thermal sensitivity

AKS 3000 is calibrated to limit ambient temperature influence on the regulating accuracy.

Pressure transmitters to be used at low temperature conditions, e.g. in suction lines, are calibrated at -10 °C and 20 °C.

In this way control accuracy is optimized in a temperature range of -30 °C – 40 °C.

Pressure transmitters for general use, e.g. at normal room temperature, are calibrated at 20 °C and 60 °C.

In this way control accuracy is optimized in a temperature range of 0 °C – 80 °C.

Ordering

Operating range [bar] (e)	Max. working pressure PB [bar]	Calibration at [°C]	Code no.			
			EN 175301-803 plug, Pg 9			
			G 3/8 A	G 1/2 A	1/4 - 18 NPT	1/4 Flare
-1 – 6	33	-10 / 20	060G1040	–	–	060G1321
-1 – 9	33		–	060G1895	060G1051	060G1007¹⁾
-1 – 12	33		060G1058	060G1896	060G1052	060G1323
-1 – 20	50		060G1049	–	060G1053	060G1010
0 – 18	50	20 / 60	–	–	060G1068	060G1325
0 – 25	50		060G1041	060G1608¹⁾	060G1080	060G1019
0 – 30	60		–	–	060G1081	060G1327
0 – 40	100		060G1066	–	–	060G1328
0 – 60	100		–	060G3631	060G1083	–

¹⁾ Calibrated as absolute pressure range:

060G1007: 0 – 10 bar (abs)

060G1608: 0 – 25 bar (abs)

Ordering standard
Performance

Accuracy	±1% FS (typ.) / ±2% FS (max.)
Non-linearity	< ±0.5% FS
Hysteresis and repeatability	≤ ±0.1% FS
Thermal zero point shift	≤ ±0.2% FS/10K (typ.) ≤ ±0.4% FS/10K (max.)
Thermal sensitivity (span) shift	≤ ±0.2% FS/10K (typ.) ≤ ±0.4% FS/10K (max.)
Response time	< 4 ms
Max. operating pressure	See ordering table

Electrical specifications

Rated output signal	4 – 20 mA
Supply voltage, [U _s] (polarity protected)	9 – 32 V DC
Supply voltage dependency	< 0.2% FS/10 V
Output limitation	22.4 mA
Power-up time	< 50 ms
Max. load, [R _L]	$R_L \leq \frac{U_s - 10 \text{ V}}{0.02 \text{ A}}$ [Ω]

**Ordering standard
(continued)**
Environmental conditions

Sensor operating temperature range		Normal	-40 – 85 °C	
		ATEX Zone 2	-10 – 85 °C	
Media temperature range				
Compensated temperature range		≤ 16 bar	LP: -30 – 40 °C	
		> 16 bar	HP: 0 – 80 °C	
Transport temperature range				
EMC - Emission				
EMC - Immunity	Electrostatic discharge	Air	8 kV	EN 61000-6-2
		Contact	4 kV	EN 61000-6-2
	RF	field	10 V/m, 26 MHz – 1 GHz	EN 61000-6-2
		conducted	3 V _{rms} , 150 kHz – 30 MHz	EN 61000-6-2
	Transient	burst	4 kV (CM), Clamp	EN 61000-6-2
		surge	1 kV (CM,DM) at Rg = 42 Ω	EN 61000-6-2
Insulation resistance				
> 100 MΩ at 500 V DC				
Vibration stability	Sinusoidal	20 g, 25 Hz – 2 kHz		IEC 60068-2-6
	Random	7,5 g _{rms} , 5 Hz – 1 kHz		IEC 60068-2-34, IEC 60068-2-36
Shock resistance	Shock	500 g / 1 ms		IEC 60068-2-27
	Free fall	1 m		IEC 60068-2-32
Enclosure				
IP65 (IEC 60529)				

Approvals

UL recognized for sale in the USA and Canada	Electrical safety	File no. E310 24, E494625
	Harzardous location	File no. E227388
CE marked according to the EMC directive		2015/30/EU
Ex evaluated for Zone 2 for sale in Europe		ATEX II 3G Ex-nA IIA T3 Gc
For sale in Russia, Belarus and Kazakhstan		EAC (EurAsian conformity)

Explosive atmospheres

Zone 2 applications	II 3G Ex nA IIA T3 Gc -10 °C < Ta < + 85 °C	EN60079-0; EN60079-15; EN 60079-7
---------------------	--	--------------------------------------

In ATEX Zone 2 applications with low temperatures cable and plug must be protected against impact.

The product was approved in compliance with ATEX. Ignition risk is evaluated in accordance to ATEX. **AKS 3000** can be applied on systems with **R290, R600, R600a** and **R1270** as the working fluid. For countries where safety standards are not an indispensable part of the safety system, Danfoss recommends the installer to seek a third party approval for the system containing flammable refrigerant. Note, please follow specific selection criteria stated in the datasheet for these particular refrigerants. This product is approved for **R290, R600, R600a** and **R1270** by ignition source assessment in accordance to standard EN13463-3.

Mechanical characteristics

Electrical connection	EN 175301-803 plug / 2 m cable
Wetted parts, material	EN10088-1-1.4404 (AISI 316L)
Housing material	EN10088-1-1.4404 (AISI 316L)
Refrigerants	DR3, DR55, DR7, HDR110, L40, R1234yf, R1234ze, R1270, R1290, R134a, R22, R227, R23, R290, R32, R404A, R407A, R407B, R407C, R407F, R410A, R413A, R417A, R422A, R422D, R427A, R438A, R444B, R447A, R448A, R449A, R449B, R450A, R452A, R454B, R502, R507, R513A, R600, R600a, R717 (NH ₃), R744 (CO ₂), R1270

**Electrical connection,
Two-wire, 4 – 20 mA**

Type code	A1
	<p>EN 175301-803-A Pg 9</p>
Ambient temperature 4 - 20 mA output	-40 – 85 °C
Electrical connection 4 - 20 mA output	<p>Pin 1: + supply Pin 2: ÷ supply Pin 3: Not used</p> <p> Connected to transmitter housing</p>

Dimensions and weight

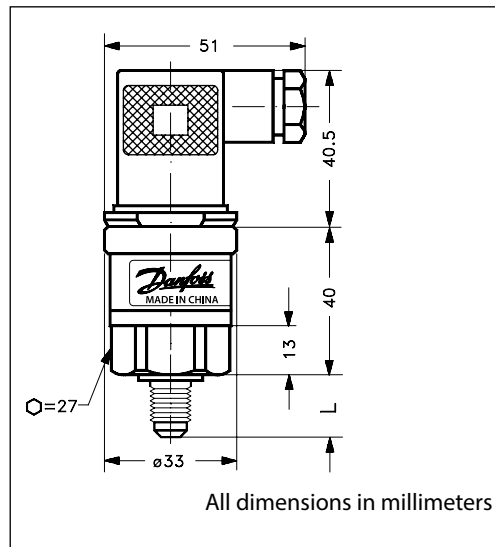

Pressure Connection	¼-18 NPT	G ¾ A ISO 228/1	G ½ A	¼Flare 7/16 - 20 UNF	Weight kg	
					plug	cable
L [mm]	16	21	20	16.5	0.15	0.20

Danfoss can accept no responsibility for possible errors in catalogues, brochures and other printed material. Danfoss reserves the right to alter its products without notice. This also applies to products already on order provided that such alterations can be made without subsequential changes being necessary in specifications already agreed. All trademarks in this material are property of the respective companies. Danfoss and the Danfoss logotype are trademarks of Danfoss A/S. All rights reserved.